

This item was submitted to Loughborough's Institutional Repository (<https://dspace.lboro.ac.uk/>) by the author and is made available under the following Creative Commons Licence conditions.



CC creative commons
COMMONS DEED

Attribution-NonCommercial-NoDerivs 2.5

You are free:

- to copy, distribute, display, and perform the work

Under the following conditions:

 **Attribution.** You must attribute the work in the manner specified by the author or licensor.

 **Noncommercial.** You may not use this work for commercial purposes.

 **No Derivative Works.** You may not alter, transform, or build upon this work.

- For any reuse or distribution, you must make clear to others the license terms of this work.
- Any of these conditions can be waived if you get permission from the copyright holder.

Your fair use and other rights are in no way affected by the above.

This is a human-readable summary of the [Legal Code \(the full license\)](#).

[Disclaimer](#) 

For the full text of this licence, please go to:
<http://creativecommons.org/licenses/by-nc-nd/2.5/>

Faculty of Social Sciences and Humanities
Department of Design and Technology

**Development of a Design Feature Database to Support
Design for Additive Manufacturing (DfAM)**

By

SHAJAHAN BIN MAIDIN

A Doctoral Thesis

Submitted in partial fulfilment of the requirements for
the award of
Doctor of Philosophy of Loughborough University

© by Shajahan Bin Maidin 2011

Abstract

This research introduces a method to aid the design of products or parts to be made using Additive Manufacturing (AM), particularly the laser sintering (LS) system. The research began with a literature review that encompassed the subjects of design and AM and through this the need for an assistive design approach for AM was identified. Undertaking the literature review also confirmed that little has been done in the area of supporting the design of AM parts or products.

Preliminary investigations were conducted to identify the design factors to consider for AM. Two preliminary investigations were conducted, the first investigation was conducted to identify the reasons for designing for AM, the need for a design support tool for AM and current challenges of student industrial designers designing parts or products for AM, and also to identify the type of design support they required. Further investigation were conducted to examine how AM products are developed by professional industrial designers and to understand their design processes and procedures. The study has identified specific AM enabled design features that the designers have been able to create within their case study products. Detailed observation of the case study products and parts reveals a number of features that are only economical or possible to produce with AM.

A taxonomy of AM enabled design features was developed as a precursor for the development of a computer based design tool. The AM enabled design features was defined as a features that would be uneconomical or very expensive to be produced with conventional methods. The taxonomy has four top-level taxons based on four main reasons for using AM, namely user fit requirements, improved product functionality requirements, parts consolidation requirements and improvement of aesthetics or form requirements. Each of these requirements was expanded further into thirteen sub categories of applications that contained 106 examples of design features that are only possible to manufacture using AM technology. The collected and grouped design features were presented in a form of a database as a method to aid product design of parts or products for AM. A series of user trials were conducted that showed the database enabled industrial designers to visualise and gather design feature

information that could be incorporated into their own design work. Finally, conclusions are drawn and suggestions for future work are listed. In summary, it can be concluded that this research project has been a success, having addressed all of the objectives that were identified at its outset. From the user trial results, it is clear to see that the proposed tool would be an effective tool to support product design for AM, particularly from an educational perspective. The tool was found to be beneficial to student designers to take advantage of the design freedom offered by AM in order to produce improved product design. As AM becomes more widely used, it is anticipated that new design features will emerge that could be included in future versions of the database so that it will remain a rich source of inspirational information for tomorrow's industrial designers.

Keywords

Additive Manufacturing, Laser Sintering, Design Support Tool, Design Feature Taxonomy, Design Feature Database

Acknowledgements

I would like to express my highest gratitude to my supervisor, Dr. Ian Campbell for his guidance, support, patience, discussions, comments and enthusiastic academic support over my time at Loughborough University.

My appreciation is also extended to all the students and professional designers who took part in the trial and contributed with valuable feedback.

My appreciation goes to my sponsors, Universiti Teknikal Malaysia Melaka (UTeM) and The Ministry of Higher Education of Malaysia for giving me full scholarship to undertake this study.

My appreciation towards all the members of the Loughborough Design School for their assistance especially in the administration and technical assistance matters.

Special thanks to my research colleagues for their encouragement and valuable discussions.

Lastly, I would like to express my highest appreciation and gratitude to my lovely wife, Latifah Binti Mohd Ali and our children Muhammad Shariq and Muhammad Shaqif for their presence, love and support throughout my PhD studies.

Shajahan Bin Maidin
Department of Design and Technology
Loughborough Design School
Loughborough University

USED ACRONYMS / ABBREVIATIONS

AM	Additive Manufacturing
2D	Two Dimensional
3D	Three Dimensional
CAD	Computer Aided Design
CAM	Computer Aided Manufacturing
CMM	Coordinate Measuring Machine
DFA	Design for Assembly
DfAM	Design for Additive Manufacturing
DFM	Design for Manufacture
FDM	Fused Deposition Modeling
GUI	Graphical User Interface
LS	Laser Sintering
NURBS	Non-Uniform Rational B-Spline
RE	Reverse Engineering
RM	Rapid Manufacturing
RP	Rapid Prototyping
RT	Rapid Tooling
STL	Stereolithography (exchange file format)
SLA	Stereolithography (apparatus)

TABLE OF CONTENTS

Abstract.....	iv
Acknowledgement	vi
Used Acronyms / Abbreviations.....	vii
Table of Contents.....	viii
List of Figures.....	xii
List of Tables.....	xvi
Chapter One: Introduction.....	1
1.0 Chapter Overview	1
1.1 Research Background	1
1.2 Research Aim and Objectives.....	2
1.2.1 Research Aim.....	2
1.2.2 Research Objectives	3
1.3 Research Scope	3
1.4 Research Questions	4
1.5 Research Strategy	4
1.6 Literature Review.....	7
1.7 Thesis Structure.....	8
Chapter Two: Design	11
2.0 Chapter Overview	11
2.1 Definition of Design.....	11
2.2 The Act of Designing.....	13
2.2.1 Aspect of Creativity	14
2.2.2 Design Knowledge	15
2.2.3 Design Research.....	17
2.3 Industrial Design	18
2.4 Models of the Design Process	19
2.5 Stages of Design Activity	31
2.5.1 Concept Design.....	31
2.5.2 Embodiment Design.....	35
2.5.3 Detail Design	36
2.6 Design Methods.....	37
2.7 Design Media	40

2.7.1	Sketching.....	40
2.7.2	Drawing	45
2.7.3	Models.....	48
2.7.4	Prototypes	50
2.8	Decision Support Systems for Design.....	56
2.8.1	Expert Systems	56
2.8.2	Case-Based Reasoning.....	59
2.8.3	Fuzzy Logic	60
2.8.4	Artificial Neural Networks	61
2.9	Summary.....	64
Chapter Three: Additive Manufacturing		65
3.0	Chapter Overview	65
3.1	Introduction	65
3.2	Definition of Additive Manufacturing.....	65
3.3	A Brief History of AM.....	67
3.4	AM Generic Process	69
3.5	AM Systems.....	71
3.5.1	Stereolithography (SLA).....	71
3.5.2	Laser Sintering (LS)	74
3.5.3	Fused Deposition Modeling (FDM)	78
3.6	Design Potential of AM	80
3.6.1	Geometrical Freedom	80
3.6.1.1	Design Complexity	80
3.6.1.3	Parts Customisation	84
3.6.1.4	Multiple Assemblies.....	85
3.6.2	Multiple Material Combinations.....	86
3.7	Applications of AM.	87
3.7.1	Consumer Items.....	88
3.7.2	Transportation.....	89
3.7.3	Medical & Healthcare.....	91
3.7.4	Sports.....	94
3.8	Challenges and Issues of AM.	96
3.9	Sources of Data for Additive Manufacturing.....	96
3.9.1	Computer Aided Design (CAD).....	96
3.9.2	Reverse Engineering	100
3.9.3	Medical Imaging.....	101
3.10	AM System Selection and Process Support Systems.....	102

3.11	Summary.....	113
Chapter Four: Design Factors to Consider for AM.....		115
4.0	Chapter Overview	115
4.1	Research Methodology for Preliminary Investigation Number One.....	115
4.2	Questionnaire Findings	118
4.2.1	AM reasons for utilisations (Question 2)	118
4.2.2	Design Factors to Consider for AM (Question 3)	123
4.2.3	Sources of Information used to Redesign for AM (Question 4).....	123
4.2.4	Choice of AM System (Question 5).....	124
4.2.5	Challenges to Designing Parts or Products for AM (Question 6)	124
4.2.6	Analysis of AM Knowledge and Design Skills (Question 7).....	125
4.2.7	Suggestions for a Design Aid Tool for AM (Questions 8 and 9).....	126
4.3	Analysis of Design Diary	127
4.4	Summary of Findings (Preliminary Investigation Number One)	127
4.5	Preliminary Investigation Number Two	128
4.6	Overview of Preliminary Investigation Number Two.....	128
4.7	Research Methodology of Preliminary Investigation Number Two.....	129
4.8	Description of Product and Discussion of Interview Content.....	132
4.8.1	Avionics Enclosure.....	132
4.8.2	Automotive Active Ventilation System.....	134
4.8.3	Medical Surgery Tools	135
4.8.4	Customised Golf Club Grips.....	137
4.8.5	Automotive Dashboard Console	139
4.8.6	Summary of Findings (Preliminary Investigation Number Two)	142
4.8.7	Comparison of Preliminary Investigation Number One and Two.....	144
4.8.8	Implication for Future Research	145
Chapter Five – AM Taxonomy of Design Features		147
5.0	Introduction	147
5.1	Background.....	147
5.1.1	Introduction to Taxonomies.....	148
5.1.2	Introduction to Design Features	149
5.2	Development of the AM design feature taxonomy	153
5.2.1	User Fit Requirement	165
5.2.2	Improve Functionality Requirement.....	166
5.2.3	Consolidation Requirement	167
5.2.4	Aesthetics and Form Requirement	168
5.3	Validation of the Taxonomy.....	169

5.4	Summary.....	171
Chapter Six – Implementation of the Design for Additive Manufacturing (DfAM)		
Feature Database		172
6.0	Chapter Overview	172
6.1	DfAM Features Database Objectives.....	173
6.2	Proposed DfAM Process.....	174
6.3	DfAM feature database development.....	176
6.4	Summary.....	186
Chapter Seven – DfAM Feature Database Validation		187
7.0	Chapter Overview	187
7.1	Introduction	187
7.2	Validation Method	188
7.3	Trial Results.....	192
7.4	Results Analysis.....	211
7.5	Questionnaire Feedback Analysis.....	214
7.6	Chapter Summary.....	219
Chapter Eight – Conclusions and Future Work.....		220
8.0	Chapter Overview	220
8.1	Research Objectives Achieved	220
8.2	Research Questions Answered.....	222
8.3	Contribution to Knowledge.....	225
8.4	Recommendations for Future Work	226
8.5	Overall Conclusion.....	227
REFERENCES:		228
Appendix A: Student Designers Questionnaire Survey.....		240
Appendix B: User Fit Requirement Design Features.....		268
Appendix C: Improve Functionality Design Features.....		276
Appendix D: Consolidation Requirement Design Features.....		284
Appendix E: Aesthetics or Customised Foam Design Features.....		296
Appendix F: Definition of the Design Features.....		308
Appendix G: Validation Feedback Analysis.....		314
Appendix H: List of Published Papers.....		324

LIST OF FIGURES

Figure 1: Overall Research Strategy	5
Figure 2: Thesis Structure	10
Figure 3: Design as an Information Knowledge Process.....	12
Figure 4: Product Design Knowledge.....	15
Figure 5: Model of the Design Process by Cross.	21
Figure 6: Model of Design Process by French.	22
Figure 7: Pahl and Beitz's Model of the Design Process.....	24
Figure 8: The VDI 2221 Model of the Design Process.	26
Figure 9: March's PDI Model of Reasoning in Design.....	27
Figure 10: Pugh Model Showing Integration among Functions.....	28
Figure 11: Product Design Specification.	29
Figure 12: A Generic Product Development Process.....	30
Figure 13: Concept Sketches for Exploring Ideas of a High Stool.....	33
Figure 14: A Classification of the Conceptual Design Techniques.....	34
Figure 15: An Appearance Model of a Desk.....	35
Figure 16: An Example of Engineering Design Detail Drawing.	36
Figure 17: Sketch of an early helicopter prototype	41
Figure 19: A 3D model of a shaft and its prescriptive sketch.....	43
Figure 18: An investigative sketch of an iron.....	43
Figure 20: An explanatory sketch of the interior of a sport car	44
Figure 21: An exploratory sketch of a truck.....	44
Figure 22: A persuasive sketch of a goggle	45
Figure 23: Concept Drawing of Audi Sport back	46
Figure 24: A presentation drawing of a Concorde seats.....	46
Figure 25: A scenario of folding and sitting on a folding chair	47
Figure 26: An example of Engineering Drawing of a Flange Housing.	47
Figure 27: A 3D sketch model made from foam.	48
Figure 28: A design development model made with clay of a motorbike.....	49
Figure 29: An appearance model of a boom box.	49
Figure 30: A functional concept model of a motorcycle.....	50
Figure 31: An appearance prototype of a camera.	52
Figure 32: Alpha prototype of a single fork bile shock absorber.....	52
Figure 33: Beta prototype of amphibious passenger coach.	53
Figure 34: An experimental prototype.	54
Figure 35: System prototype of a propulsion unit.	54
Figure 36: Tooling prototype for a consumer product.....	55
Figure 37: Off-tool prototype for a consumer product.....	55
Figure 38: A Basic Structure of Expert Systems.	57
Figure 39: A typical case base reasoning cycle.	59
Figure 40: A basic structure of interconnected group of nodes.	61

Figure 41: Screen shot of shapes produced with EFD.	64
Figure 42: Expansion of additive technology.....	68
Figure 43: Seven AM Generic Steps.....	70
Figure 44: Schematic Diagram of SLA Process.....	72
Figure 45: Example of a fruit tray produce with SLA process.....	73
Figure 46: Schematic Overview of LS Process.....	76
Figure 47: Examples of a laser sintered chair.....	76
Figure 48: Schematic Overview of FDM process.....	78
Figure 49 : Bike Gauge Pod made with FDM system.....	79
Figure 50: Chair developed with laser sintering.....	81
Figure 51: Example of parts consolidation in aircraft ducting.....	83
Figure 52: Consolidation of the control pod.....	83
Figure 53 : Golf club grip.....	85
Figure 54: AM weaved bag.....	86
Figure 55: Tooth brush.....	87
Figure 56: Shower Gel Dispenser.....	87
Figure 57: Application of AM worldwide.....	88
Figure 58: Various AM Consumer Products.....	89
Figure 59 : Metal laser sintered aerospace parts.....	90
Figure 60: Sintesi – AM application in concept car.....	90
Figure 61: Structural parts of a motor produced with laser sintering (in white).....	91
Figure 62 : Custom skull implant.....	92
Figure 63: Custom dental bridge.....	92
Figure 64: Custom knee implant.....	93
Figure 65: Additive Manufacture of Hearing Aids.....	93
Figure 66: Additive manufacture customised soccer shoe.....	94
Figure 67: Personalised sports-helmet manufactured using Laser Sintering.....	95
Figure 68: SCUTA project.....	95
Figure 69: CAD visualisation, wireframe (left), solid & surface model (middle), photorealistic image (right).....	98
Figure 70: The architecture of a computer-aided design (CAD) system.....	99
Figure 71: A 3D laser scanning process.....	101
Figure 72: From conventional design to AM.....	107
Figure 73: The LS part and the original bracket.....	107
Figure 74: (a) Placement of prototype fabrication within design process and (b) FDM decision support system in prototype generation.....	108
Figure 75: (a) Traditional RP process chain (b) Inclusion of 3D scanning system. Source: (Page et al., 2005).....	110
Figure 76: (a) Line drawing of the laser, CCD camera and the object (b) laser line projection on the part.....	110
Figure 77: Speaker system redesigned for AM.....	119
Figure 78: Multi-meter redesigned for AM.....	120
Figure 79: Toothbrush redesigned for AM.....	121
Figure 80: Wrist watch redesigned for AM.....	122

Figure 81: Enclosure on Subsonic UAV (in white).....	132
Figure 82: Internal chassis & support & external sleeve of enclosure	133
Figure 84: Mounting boss of enclosure	133
Figure 83: Snap fit hook of enclosure.....	133
Figure 85: Integrated cable supports.....	133
Figure 86: Active Car Air Ventilation System.....	134
Figure 87: Medical equipment produced by laser sintering	135
Figure 88: Customised AM Golf Club Grip.	138
Figure 89: Automotive Dashboard Console and Navigation Unit	139
Figure 90: AM enabled design feature	141
Figure 91: Final design.....	141
Figure 92: AM Design Process.....	143
Figure 93: A taxonomy of solid models features	151
Figure 94: Free form feature taxonomy	152
Figure 95: A Generic Freeform Feature Taxonomy.....	153
Figure 96: Taxonomy of Internal and External AM Design Features.....	155
Figure 97: Taxonomy of Functionality and Form AM design features	156
Figure 98: AM application design features	158
Figure 99: Taxonomy of AM functionality & complex geometrical features	159
Figure 100: AM reasons for utilisation design feature taxonomy version 1	161
Figure 101: AM reasons for utilisation design feature taxonomy version 2	162
Figure 102: AM design feature taxonomy version 3 (simplified layout)	163
Figure 103: Proposed DfAM Process.....	175
Figure 104 : Screen shot of the welcome page of the DfAM feature database	178
Figure 105: General Information Screen	178
Figure 106: AM feasibility validation screen	179
Figure 107: AM is not suitable for production volume more than 10, 000 units	180
Figure 108: Message showing that AM is not suitable	181
Figure 109 : Message showing that AM is potentially suitable	181
Figure 110: AM Concept Profile Generation Screen	182
Figure 111: Categories that have been enabled	183
Figure 112: Feature example under the customised form.....	183
Figure 113: Quick Search Screen	185
Figure 114: Juice Squeezer sketch without using DfAM feature database.....	193
Figure 115: Juice Squeezer 3D CAD for Injection Moulding	194
Figure 116: Juice Squeezer sketch using DfAM feature database.....	195
Figure 117: Juice Squeezer CAD with using DfAM feature database	196
Figure 118: Shaver sketch without using DfAM feature database.....	198
Figure 119: Shaver CAD without using DfAM feature database.....	199
Figure 120: Shaver sketch using DfAM Feature Database	200
Figure 121: Shaver 3D CAD using DfAM Feature Database.....	201
Figure 122: Exploded Sketch of Cold Core Treatment Wand.....	202
Figure 123: Cold Core Treatment Sketch for Injection Moulding.....	203

Figure 124: CAD Model of Hand Held Cold Sore Treatment Wand for Injection Moulding.....	204
Figure 125: Cold Sore Treatment Wand Sketch for AM.....	206
Figure 126: Cold Sore Treatment Wand Section View Sketch for AM.....	207
Figure 127: 3D CAD Models of Hand Held Cold Sore Treatment Wand for AM.....	208
Figure 128: Sketch of a hand held kitchen blender for injection moulding.....	209
Figure 129: 3D CAD models of hand held kitchen blender for injection moulding..	209
Figure 130: Sketch of a hand held kitchen blender for AM.....	210
Figure 131: 3D CAD model of hand held kitchen blender for AM.....	211
Figure 132: Responses to Question One	215
Figure 133: Responses to Question Two	216
Figure 134: Responses to Question Three.....	216
Figure 135: Responses to Question Four.....	217
Figure 136: Responses to Question Five	217
Figure 137: Responses to Question Six.....	218
Figure 138: Responses to Question Seven.....	218

LIST OF TABLES

Table 1: Keyword used as part of the literature review.....	8
Table 2: International Definitions of Industrial Design.	19
Table 3: Recommended Product Development Methods.....	37
Table 4: Classification of Design Methods.	38
Table 5: Category of Design Methods.....	39
Table 6: Creative and Rational Methods.....	40
Table 7: Classification of Sketch Groups.....	42
Table 8: Summary of the Stereolithography Process.	74
Table 9: Summary of Selective Laser Sintering Process.....	77
Table 10: Summary of Fused Deposition Modelling Process.....	79
Table 11: Structure of decision support problem.....	109
Table 12: Guideline for the project.....	116
Table 13: Interview Questions.....	118
Table 14: List of designers and their respective products designed for AM.....	130
Table 15: Semi-structured interview questions.....	131
Table 16: Requirements of a taxonomy.....	149
Table 17: Description of five versions of the AM design features taxonomy.....	154
Table 18: User Fit Requirement Design Features.....	165
Table 19: Improve Functionality Design Features.....	166
Table 20: Consolidation Design Features.....	168
Table 21: Aesthetics or Form Requirement Design Features.....	169
Table 22: Number of design feature for a specific AM reasons and application.....	177
Table 22: AM feasibility scoring matrix.....	181
Table 23: Result of concept profile selection.....	184
Table 25: Design Brief for First Trial.....	189
Table 26: Design Brief for Second Trial.....	191
Table 27: Products Redesigned by the Participants.....	192
Table 28: Range of features used from the DfAM feature database.....	213

Chapter One: Introduction

1.0 Chapter Overview

This chapter provides the reader with the research background, scope, aims and its objectives. It also provides a review of the research methodology adopted in this research and finally the overall thesis structure is presented to guide the reader through this work.

1.1 Research Background

The motivation of this research has come from an interest to support the designing of parts or products with the assistance of tools particularly for AM. Manufacturing practices have currently witnessed a shift in the way a product is designed and produced. The term AM refers to a group of technologies that currently has the potential and promise for great flexibility in supporting customisation of products via creative design, less tooling cost and fast product development cycle times that enable companies to be competitive in the market.

One of the important aspects for a part or product to be successful in the current economic environment is its innovative features and aesthetic appeal. Usually, industrial designers seek to impart innovative features and aesthetic appeal design issues by referring to various visual sources of information such as websites, patents and literature. Gathering information from these sources, they will develop new design concepts that describe the form, functionality, ergonomics and usability for the part or product. At present, most industrial designers design Additive Manufactured parts or products without any specific design support tool, thus they might sometimes reach wrong perceptions of the value and advantage of designing for AM. This practice is time consuming and costly. Based on these circumstances, it is the aim of this research to develop a tool which will assist industrial designers to design parts or products particularly suitable for AM.

Use of current AM technologies is developing a large amount of design information such as innovative design features and complex geometry that is generated when designing a product or part for AM. This information often does not get recorded, resulting in a potential loss of important design knowledge. Different methods have been offered for capturing and documenting various domains of design knowledge. However, little work has been undertaken on understanding, capturing and modelling the design process for AM products that is needed to create a tool that can assist designer's to design products for AM. Furthermore, due to the flexibility that AM provides to the design of complex parts and products, the knowledge space in this domain is incomplete and dynamic.

This research attempts to show how the results from the collection of Additive Manufactured enabled design features can be used to produce solutions for design for AM. Current practice of designers' methods and knowledge in designing for AM was observed. Current systems available to support the process stated above were explored through a cross disciplinary literature review in AM, design support tools and design methodology. The outcome of the research will be a methodology for gathering, presenting and disseminating AM design feature knowledge to increase the effectiveness of designing for AM.

1.2 Research Aim and Objectives

1.2.1 Research Aim

The aim of the research is to develop a design support tool to aid the design of products or parts for AM, particularly the laser sintering (LS) technique to enable the achievement of specific Additive Manufactured design features.

1.2.2 Research Objectives

The objectives of the research are:

1. To identify the methods, tools and strategies that are commonly applied within the practice of industrial design.
2. To investigate tools, methods and strategies used to support AM.
3. To identify a suitable structure and format that could guide the development of a tool to support industrial designers to design for AM.
4. To recommend a tool or approach that could support industrial designers to develop product design for AM.
5. To test and validate the tool.

1.3 Research Scope

The scope of the research is to investigate ways to improve the interaction between industrial designers and AM through the use of computer based design tool. The vital tasks are to establish means to support this specifically for LS. This needs a good understanding of the capability and limitations of the system. The procedural knowledge and methods of professional designers that currently design and develop AM enabled design features for part or product customisation, consolidation, functionality improvement and for aesthetic requirement will also be important subjects. The final part of this project is to implement the information gained from the research to enable the development of the design support tool. The tool will be influenced by the type of AM system being considered, the material to be used and various other factors. To provide a support tool for all the available AM systems would be extremely challenging and so the research will focus initially on LS. Even though laser sintered metal parts are more likely to be used as final-use components or products than are polymer-based parts, most of the available Additive Manufactured design features that have been designed and produced are made using polymer-based powders. As a result a decision was made to focus the research on polymer based parts.

1.4 Research Questions

To take advantage of the benefits offered by AM, industrial designers have to equip themselves with a methodological approach using a suitable tool to enable effective generation of product concepts that are suited to production by AM. In order to establish the method or tool, this research shall focus upon the following research questions:

1. What are the challenges for industrial designers when designing for AM?
2. What are the reasons for designing AM parts and products?
3. What are the methods currently employed by professional designers to design and develop parts or products with AM?
4. What design information should be presented to industrial designers to enable effective generation of product design that are suited to production by AM?
5. How can the information about the AM design features be structured to enable the creation of a DfAM tool?
6. What is the optimum way of presenting AM design knowledge obtained to industrial designers?

1.5 Research Strategy

The strategy adopted in this research consists of five phases. Figure 1 provides an overview of the research strategy adopted within this research.

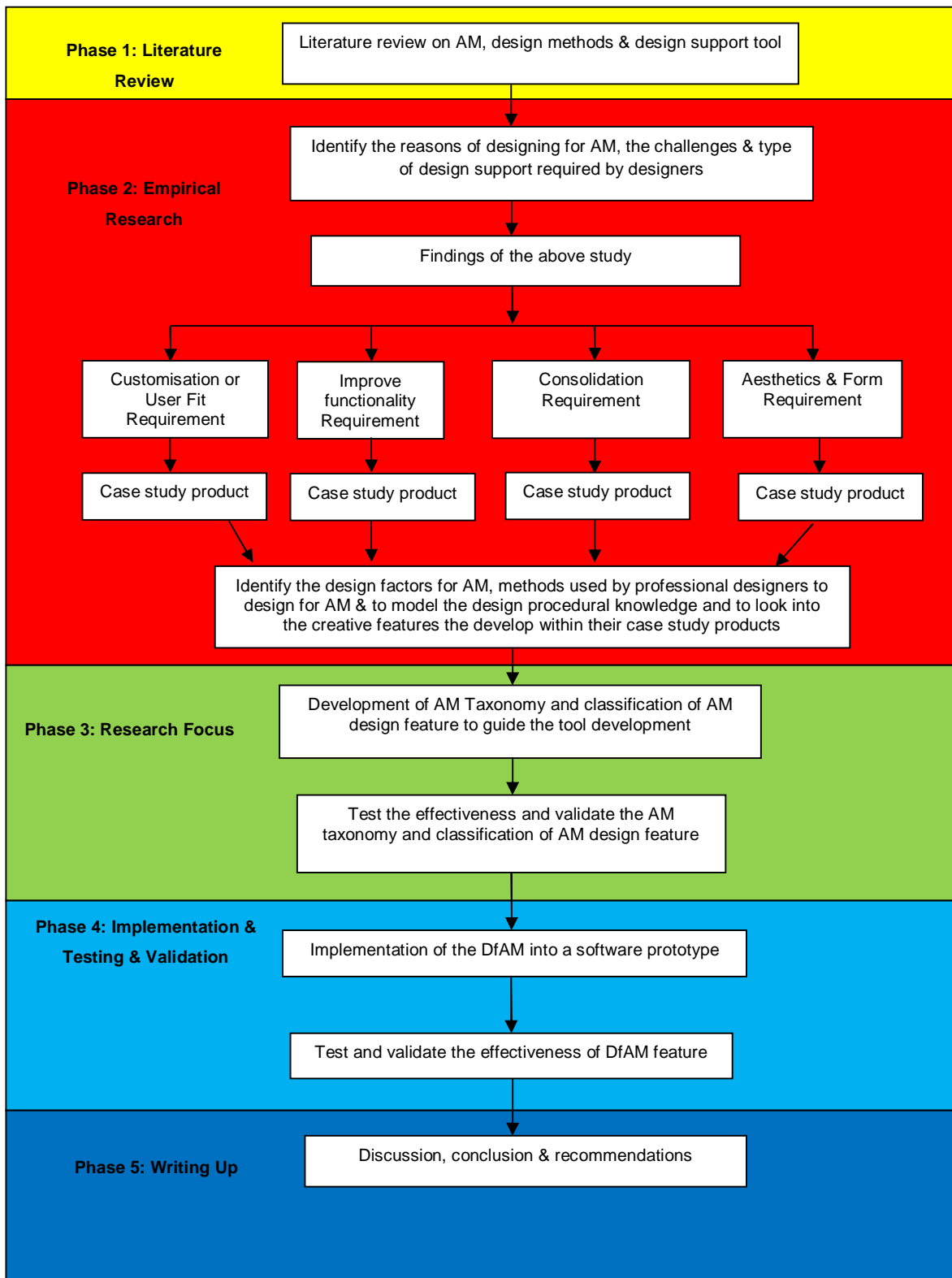

Figure 1: Overall Research Strategy

The research began with a literature review. The literature review presented in Chapters Two and Three is based on readily available books, journal and conference proceedings articles and PhD theses. It encompassed the subjects of design and AM and through this the need for an assistive design approach for AM was identified. A thorough literature review was essential at the initial research stage because it determined the latest knowledge and also acted as a foundation for subsequent stages of the research. Undertaking the literature review also confirmed that little has been done in the area to support designing of AM parts or products. The literature review was followed by a series of structured interviews as part of a pilot study to identify the reasons for designing for AM, the need for a design support tool for AM and current challenges to industrial designers designing parts or products for AM, and also to identify the type of design support they required. The details and results of the interview are described in Chapter Four.

Having identified the main challenges and issues, the next phase of the research was an in-depth analysis of a series of case studies, coupled with professional designer interviews. Capturing and analysing design experts' opinions on AM product customisation, parts consolidation and aesthetic aspect in AM product design helped to create an understanding of the design factor should be consider for AM. It also provides insight into the professional designers practical design procedures with the aim of making this knowledge explicit. Results from the interviews, together with their AM enabled design features generated from the product design case studies, were used later in the formulation of a suitably assistive product design approach. This led to the representation of detailed design knowledge and the production of a "beta" DfAM tool.

Establishment of these initial pilot studies in phase two moved the research into its third phase, the research focus of which ultimately led to the development of a prototype tool. Based on the initial literature review and the interviews, it became apparent that the prototype tool would need to be able to provide visual examples of AM enabled design features for the four AM utilisation reasons identified (i.e. user fit requirement, part or product functionality improvement, consolidation requirement and aesthetics or form requirement).

The fourth phase of the research involved the testing and validation of the prototype tool. In order to assess the effectiveness and usability of the tool, a series of user trials were conducted to gauge the responses of participants. The final phase of the research was to analyse the research results to develop the concluding discussion.

1.6 Literature Review

The web search during the literature review centred on the use of online databases such as Science Direct, Emerald and Springer Link that can be accessed from Metalib, the University gateway for various online journal databases. Conference proceedings and PhD theses were also accessed. Aside from the direct searches, relevant sources that were found provided additional references. Table 1 shows the list of keywords that were used to facilitate the literature review. Another important element of the review process was the use of alternative terminology to direct further searches. This applies particularly to AM as there are various terms used to describe it.

In order to obtain up to date information on the subject of design and AM, alert was used to automatically receive notification of the latest journal publication on relevant subjects. In order to manage the references used, Refworks an online database management tool provided by the University, was used. However, towards the end of the research, it was found that using a stand-alone package, called EndNote X1, was more convenient because it does not require web access to insert the citations and was relatively easy to use.

Major Keywords	Other Keywords
Additive manufacturing	Design engineering
Case base reasoning	Design knowledge
Concept design tool	Design process
Conceptual design	Direct digital manufacturing
Conceptual design method	Engineering design knowledge
Conceptual development tool	Knowledge acquisition
Design	Knowledge engineering
Design feature	Knowledge management
Design methodology	Knowledge reuse
Design process	Layered manufacturing
Design support tool	Management of design knowledge
Feature base conceptual design	Product design knowledge
Feature base design	Rapid manufacturing
Fuse deposition modeling	Rule base system
Industrial design	Solid freeform manufacturing
Industrial designers	Design knowledge reuse
Knowledge base design	Tacit knowledge
Product conceptual design	Artificial intelligent
Product development	Genetic algorithms
Selective laser sintering	Fuzzy logic
Stereolithography	Expert systems
Taxonomy	

Table 1: Keyword used as part of the literature review

1.7 Thesis Structure

This thesis is divided into eight Chapters as shown Figure 2. Chapter One introduces the research. It briefly explained the research background, the aim, the objectives, the scope of the research and the research questions. It also briefly explained the research methodology.

Chapter Two encompasses a general overview of the subject of design, its processes, design methodology and its successes across wide applications. This chapter also encompasses a general overview of design support systems and decision support systems for AM. It is intended that this chapter should give an overview of techniques that could be used to help realise the DfAM tool.

Chapter Three captures various aspects and thoughts on AM. A comprehensive literature surveys on various thoughts, work and research on AM, particularly related to the issues related to and application of LS, FDM and SLA are explored. Chapter Four present two pilot studies conducted to provide some initial information and data as well as to guide the research. These chapters explain about the method used in the study, the participants involved, the process followed and the tools used for the study. It is intended that this chapter should cover the design factors that should be considered for AM, reasons for design for AM and challenges of designing for AM. In addition, by undertaking the pilot study it was found that there are various creative design solutions that could be collected and realise the development of a DfAM tool.

Chapter Five discusses the development of the taxonomy that classify AM enabled design features as a guide to the development of the DfAM feature database. Chapter Six details the approach that was used to implement the DfAM feature database prototype, including the tool structure, its content and its functions. Chapter Seven discusses the validation of the DfAM feature database prototype tool. Chapter Eight discusses how meeting the research objectives and answering the research questions has led to the development of the DfAM design feature database prototype tool to support product design for AM. It also offers conclusions from the work that was conducted and identifies potential direction for future research and development. Figure 2 shows the thesis structure.

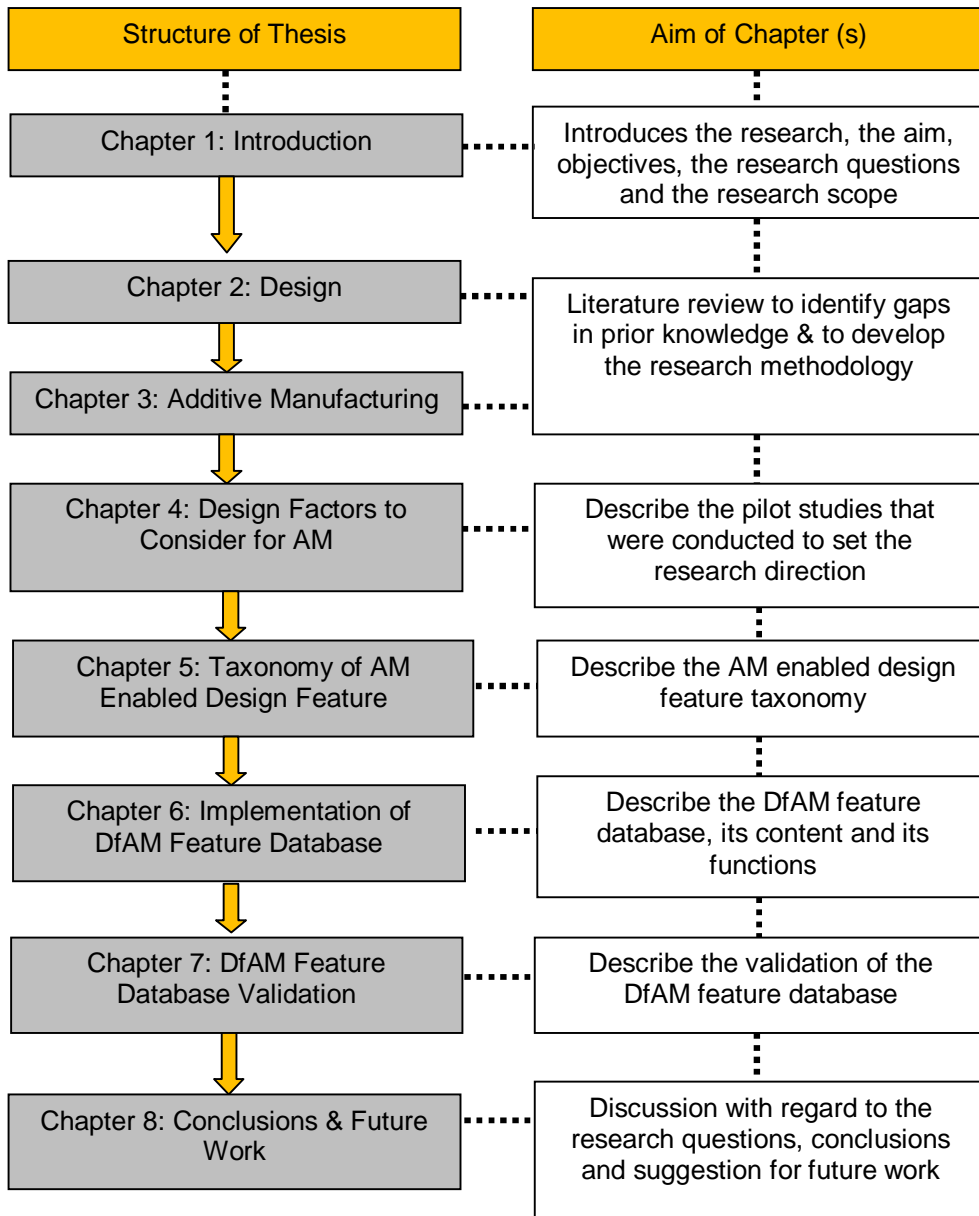

Figure 2: Thesis Structure

Chapter Two: Design

2.0 Chapter Overview

This chapter presents a literature review regarding the subject of design and captures various aspects and thoughts on it. It encompasses the definitions, the design process, the design methods, the characteristics and applications of design. It is intended that this chapter should give some clear literature background on the understanding of the design process and its development in today's world of design research. First, a review of the literature for the definition of the term 'design' is presented. A discussion of the act of design follows. Next, the type of knowledge associated with design has been discussed. Finally, various thoughts on the process of design, methods of design and the techniques used in design decision support system particularly for AM have been reviewed.

2.1 Definition of Design

There exist several definitions of design, as well as design process models, design theories, and design methodologies (Cross, 2006),(Lawson, 2006),(Pugh et al., 1996),(Ulrich and Eppinger, 2004),(Eder and Hosnedl, 2008). The ability of humans to design is one of the several forms or fundamental aspects of human intelligence compared to animals and machines (Cross, 1990). Human beings' are a special kind of designer and their design philosophy influences their life and environment. Everything around us has been designed to fulfil some need. For example clothes, furniture, machines, transportation, communication systems and even food have been designed to meet our requirements. In general, design represents an answer to a problem that has visible form, shape and function. This statement is consistent with what Stoll said, that the primary objective of design is to make peoples' lives better, where design responds to technical, functional and cultural needs that communicate meaning and emotion with appropriate form, structure and manufacture (Stoll, 1999). According to Lawson (2006, p3) the word "design" can be related either to the end product or to the process. As a verb, "to design" refers to the process of originating and developing a plan for a product, structure, system, or component with intention

(ibid). As a noun, "a design" is used for either the final solution plan (e.g. proposal, drawing, model, description) or the result of implementing that plan in the form of the final product of a design process (ibid).

Design encompasses a wide range of disciplines including industrial design, engineering design, architecture, graphics design, fashion design, furniture design, etc. All these professions define design differently and all have their own unique views on design. However, many of these professions view design as communication process (Crilly et al., 2008). Design can be considered to be an information process or an information transformation process (Zha et al., 2008). The various design states each contain different levels of information; however, the process of transformation from one information state to another is the result of decision processes, driven by knowledge and information (Hicks et al., 2002). Figure 3 demonstrates that both information and knowledge contribute significantly to the transformation and creation of the designed artefact, for all aspects but the inventive element of the creativity phases (ibid). Therefore, knowledge and information provide the basis of all possible decisions.

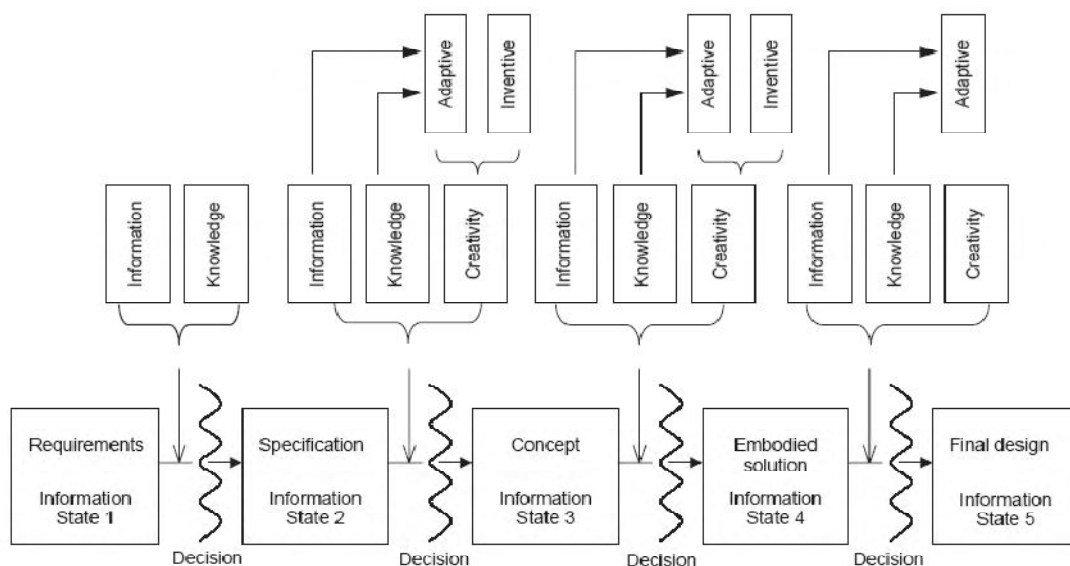

Figure 3: Design as an Information Knowledge Process (Hicks et al., 2002)

Design is also recognised as having similarities to art, rather than being a pure science (Kemp, 2009). Science is governed by laws written as formulas and constraints, whereas art is the process or product of material arranged in a way that appeals to the senses or emotions. Art encompasses a diverse range of human activities, creations, and modes of expression, including music and literature (ibid). In clarifying between art and design, Eder (2008, p3) states that “*design unlike art, requires practical justification in being societal, functional, meaning full and concrete*”.

Schon’s work (1983) provided an important step when describing design as a process of “reflection in action” where, through evaluation and reflection, design problems are restructured and improved. This particular paradigm considers the importance of observing and doing in learning to design with the emphasis on the building of a rich experiential base.

Whilst there may be some dispute about the precise definition of the term ‘design’, it is recognised universally as a purposeful and creative activity. In summary, design seeks to create things with the purpose of satisfying certain requirements in new ways that improve the quality of lives. In industrial design, a variety of requirements must be considered ranging from functionality and usability to pleasure. However, design is more than just translating a set of requirements into a product. Also, and more importantly, it involves finding new requirements. Thus, design involves finding cost effective and reliable solution for a problem. This is where creativity, knowledge and experience of an industrial designer is very important.

2.2 The Act of Designing

Designing is a process that all people do. We decide our own fashion style, we plan our daily schedules, we arrange the furniture in our rooms, among many other tasks that require processes similar to design. However, design activities are more visible in creative professions such as art, architecture, engineering, graphic design, and product design. The ability to design varies between people. However, to improve the ability of designing, knowledge, training and experience is required.

Design is a complex activity, involving artefacts, people, tools, processes, organisations and the environment in which this takes place. According to Eder (2008,p12), *“Designing is a process of formulating a description for an anticipated process systems and/or object systems that is intended to transform an existing situation into a future situation to satisfy needs”*. Examples of a process system in this definition are transportation, travel service, catering, maintenance and repair, etc. and examples of object systems are furniture, aircraft, food, machines etc. The definition of designing in this case involves continuous improvement of human situations by the anticipation of their future requirements and directing activities toward these goals.

2.2.1 Aspect of Creativity

Design is a purposeful activity involving creative thinking and problem solving (Ye et al., 2008). Design and knowledge have a very strong association: recollection and application of knowledge can be considered as a straightforward and practical design process (Baxter et al., 2008). Emerging new techniques, devices and the globalisation of the product market are pushing creativity to its limits. Designers in every industry are under a lot of pressure to quickly produce high-quality products (Brandt et al., 2008).

In recent years a number of studies have taken place with the aim of identifying and understanding aspects of creativity in design (Liu, 2000), (Gero, 1996), (Carayannis and Coleman, 2005), (Bonnardel and Marmèche, 2005),(Howard et al., 2008). These studies suggest that creative designing involves movement from one ‘solution space’ to another.

There are many interpretations and definitions of the concept of creativity. A review of the literature provides four basic definitions of creativity. The first relates to output where a product is judged to be creative by being original and having appropriate value and use (Gero, 1996). The second relates to the process to generate creative thought and action through a number of phases and techniques (Howard et al., 2008). The third definition refers to characteristics and personality traits which are said to be exhibited by creative individuals (Carkett, 2004). The final definition is that

of environment which includes both social and physical factors (Eder and Hosnedl, 2008). These aspects of creativity have been explored in a number of ways which include the study of the methods and models of designing and supporting technology that will be described in the next section.

2.2.2 Design Knowledge

Many types of knowledge are recognised in the literature; however, little work has been done on the research of knowledge in product design, such as what knowledge is used in the product design process (Fu et al., 2006). According to Fu et al. (2006), based on analysis of decision making and product design process, knowledge in product design is classified into four types as shown in Figure 4:

- i. market knowledge;
- ii. human knowledge;
- iii. technology knowledge;
- iv. procedural knowledge

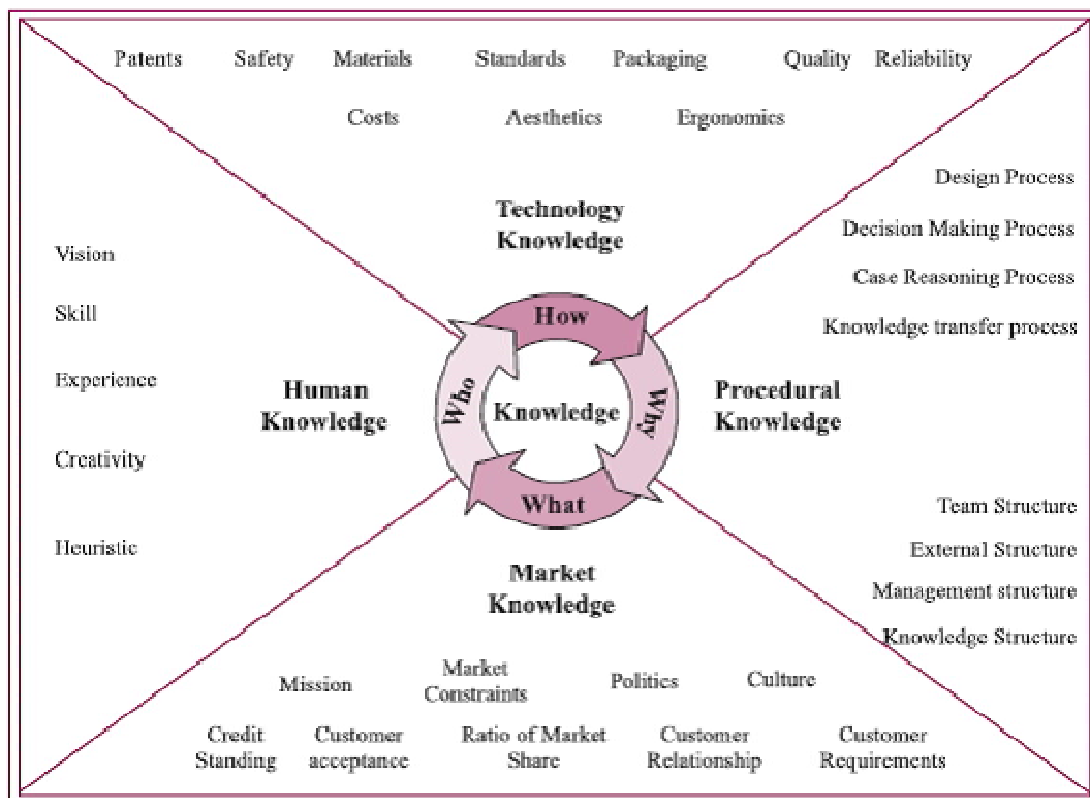

Figure 4: Product Design Knowledge.
(Fu et al., 2006)

Market knowledge represents the knowledge of interacting with the external interface like customers, partners, suppliers and other stakeholders (Fu et al., 2006). This knowledge consists of knowledge of marketing channels, customer relationships and the strength and loyalty of these. Market knowledge is important for a designer to know the objective of a product design.

Human knowledge represents the knowledge internalised in a person, such as skills, experience, creativity, etc (ibid). Within each designer resides the human knowledge the team seeks to utilise. Human knowledge is of vital importance because it is the source of innovation and knowledge generation.

Technology knowledge refers to knowledge about technologies. This form of knowledge includes inventions, publications, trademarks, patents, knowledge recipes, etc (ibid). Technology knowledge is part of the core competence of a design team.

Procedural knowledge refers to knowledge about how to accomplish an end (ibid). It deals with the mechanisms and structures used to execute the design activity. Procedural knowledge is the supportive infrastructure for human knowledge, technology knowledge and market knowledge.

Schön (1983) studied work in five professions (engineering, architecture, management, psychotherapy and town planning), from which he developed a view of expert problem solving which characterises two primary modes of activity. One he calls knowing-in-action, the other reflection-in-action (Schön, 1983). In both cases, the knowing is in the action and it is done spontaneously. It is thus the cognitive state of an individual engaged in building the solution. It is unselfconscious, non-reflective, and non-rational in nature, controlling action in relation to available artefacts.

Knowing-in-action refer to the knowledge we reveal in our intelligent actions such as driving a car and private operations such as making a calculation or analysis (ibid). Schön also identifies a second kind of action which serves to shape activity, because it is embedded in it:

“In an action present—a period of time, variable with the context, during which we can still make a difference to the situation at hand—our thinking serves to reshape what we are doing while we are doing it. I shall say, in cases like this, that we reflect-in-action” (Schön, 1983 p49).

It is upon reflecting-in-action that Schön mainly focuses, and its interplay with knowing-in-action. Reflection-in-action is the designers’ response to how they perceive the current problem state as it “talks back” to them through their “reflective conversation” with the external world with which they are working.

2.2.3 Design Research

Design research aims to increase the understanding of the phenomena of design in all its complexity and the development and validation of knowledge, methods and tools to improve the observed situation in design (Fu et al., 2006). The field of literature commonly known as design methodology is primarily concerned with the study of how designers work and think, the establishment of appropriate structures for the design process, the development and application of new design methods, techniques and procedures and reflection on the nature and extent of design knowledge and its application to design problems (Cross, 2006 p35).

The methods used in the study of design vary from reports from designers themselves, through to observation of designers at work, experimental studies based on protocol analysis and interviews with professional designers. However, there is no single model which is agreed to provide a satisfactory description of the design process. Instead most methods have a well defined and narrow focus ranging from the generation of mechanism concepts (Pahl and Beitz, 1996),(Eder and Hosnedl, 2008) through to the management of the project risk (Ulrich and Eppinger, 2004). Even so, implementation and use of such methods is often problematic (Clarkson and Eckert, 2005).

Research comparing how designers and scientists solved the same problem was undertaken by Cross (1989). The evidence from the study suggested that scientists solved the problem by analysis whereas designers solved the same problem by

synthesis. Scientists use problem focused strategies whereas designers use solution focused strategies (ibid). The designers' problem solving strategies are due to the nature of the problems they normally tackle. Some of the problems may not be able to be stated explicitly, thus the designer has to determine the starting point and suggest tentative solution areas. Solution and problem are then both developed in parallel and this leads to a creative solution. Thus, the solution focused strategies of designers are found to be the best way to tackle design problems, which are by nature ill defined problems (ibid).

2.3 Industrial Design

This research is concerned particularly with industrial design, thus a specific definition is necessary. Industrial design can be defined as the idea generation, concept development, testing and manufacturing or implementation of a physical object or service (Ulrich and Eppinger, 2004). Aesthetics is considered central to product design but product designers also deal with other important aspects including functionality, technology, ergonomics, usability, materials selection and environmental issues.

According to the Dictionary of Art Terms, "*industrial design is the reasoned application of aesthetics and practical criteria for the design of machine made artefacts, in the hope of creating a successful marriage between aesthetics and functionality*" (Lucie-Smith, 2004). The International Council of Societies of Industrial Design (ICSID) identifies industrial design as, "*a creative activity whose aim is to establish the multi-faceted qualities of objects, processes, services and their systems in whole life-cycles*".

Table 2 presents a selection of definitions from around the world as to various perceptions of industrial design. The table clearly shows the word industrial design means different things to different people. However, generally all these terms describe what the generic act of designing involves.

Country	Profession Title	Definition
UK	Industrial Design	<i>“making designs for objects to be produced by machines”</i>
America	Industrial Design	<i>“design is concerned with the appearance of three dimensional machine made products”</i>
Italy	Disegno Industriale	<i>“giving products a beautiful attractive form”</i>
German	Industrielle Formgebung	<i>“design of the external appearance of products used in industry”</i>
Japan	In-da-su-toa-tu de-za-in	<i>“design which takes both usefulness and attractiveness into account”</i>

Table 2: International Definitions of Industrial Design.
Adapted from: (Holmes et al., 1995)

This research prefers to adopt the comprehensive term used by the Industrial Designers Society of America (IDSA) that refers to industrial design as *“the professional service of creating and developing concepts and specifications that optimises functions, value and appearance of products and systems for the mutual benefits of both user and manufacturer”*. The term product design and industrial design have often been used interchangeably in literature. The British Design Council also uses these two terms to describe product development activities. As this term describe comprehensively the acts of designing of an industrial designer and to be consistent, only the term industrial design will be used for this research.

2.4 Models of the Design Process

Design is a most ‘complex and intellectual human activity’ which still needs further explanation and understanding (Gero, 1996). Design is thus often quoted as “ill structured” because it is difficult to describe the process satisfactorily and it is an equally challenging task to describe the relationships between models concerned with its various aspects (Gonnet et al., 2007). Theory and research in design have moved a long way from the 1960s positivist approaches where design was viewed as a logical search process to find a solution (Dorst and Dijkhuis, 1995). This

approach is reflected in various sequential linear models representing the design process (Pahl and Beitz, 1996), (Eder and Hosnedl, 2008) & (Ulrich and Eppinger, 2004). Investigations into design practice have motivated design researchers whose main concern has been to capture patterns in the design process. These patterns, which assist in the development of design methodologies, suggest that the design process can be divided into various stages with different tasks in each one.

To study a complex area of human activity such as design, the normal methods employed would be observational study, protocol analysis, interviews and case studies (Cross 2006). Then the design process will involve a degree of interpretation. Then a model that could explain the phenomena as observed and described is made. That explanatory framework could then be used to prescribe ways in which practice could be improved, developing methods and tools to support the designers (ibid). However, this is not what has happened in the field of design research. The field of design research emerged from practitioners developing ways of working to help them cope with the problems they faced (Dorst and Dijkhuis 1995).

A number of formal structures and frameworks aimed at a better understanding of the design process have been suggested from many different disciplines. For example, engineering design (Eder and Hosnedl, 2008), (Pahl and Beitz, 1996) and industrial design (Pugh et al., 1996). Depending on the domain and on the problem being addressed, design methodologies can vary. (Boyle, 1989) proposes a classification that splits design into three broad methodologies: analytical, procedural, and experimental design. The concepts behind this classification are those of object, attributes, and operations as well as the different roles that are assigned to humans and machines in these classes of design methods. The three categories proposed by Boyle can be summarised as follows:

- i. Analytical or attribute-centred design, in which the attributes of the objects are used to determine the appropriate design actions. A design solution is automatically synthesized from the object attributes and the design objectives.

- ii. Procedural or operation-centred design is based on using procedures to perform operations on an object with the aim of transforming it into one having the desired attributes.
- iii. Experimental search or object-centred design involves working through an available set of objects in order to find one whose attributes best match the design objectives.

Breaking down complex design problems into smaller ones assists designers to tackle design problems in a logical way. Several authors have proposed different methods which divide the design process into stages. These methods are similar in that the phase where exploration of designs is performed with more intensity is located in the early stage of the process (Cross, 2006). Models of the design process are often illustrated using a flow diagram with a sequence of stages. Cross (1989) proposed a four stage design model as shown in Figure 5 in which the designer first explores the ill defined problem space before generating a concept solution. This is then evaluated against the goals, constraint and criteria of the design brief. The final step is to communicate the design specification either for manufacture or integration into a more complex product. A feedback loop is included if the solution is not satisfactory.

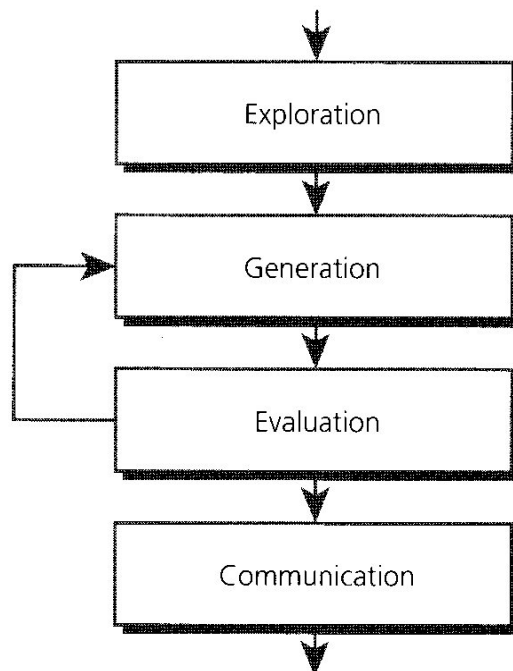

Figure 5: Model of the Design Process by Cross.
(Cross, 1989)

Figure 6 illustrates a model suggested by French (1999). The process generally starts with an initial need or motivation and ends with the necessary information, such as drawings or construction plans. Every stage is often repeated several times and sometimes feedback loops between stages are necessary in order to continue the process.

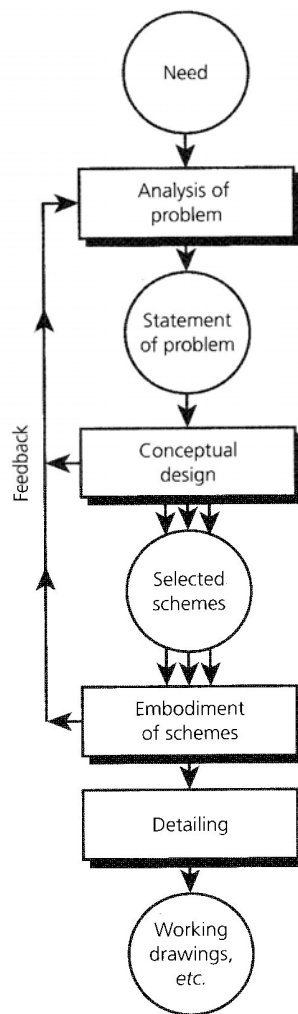

Figure 6: Model of Design Process by French.
(French, 1999)

The first task of the design process is generally 'analysis of the problem', or clarification of the task. To realise the clarification, a requirement list should be defined that includes the inputs and outputs of the required function of the design. In order to analyse a problem it is often necessary to go one step forward and generate design solutions. This indicates that designers learn about the problem as they generate designs. Often, as Lawson (2006) found, designers continue to search for

alternative solutions through feedback loops even when they have already developed satisfactory design solutions.

In the second stage, namely the 'conceptual design stage', designers generate broad solutions and, according to French (1999), it is at this point where many significant decisions are taken. This stage can be broken down into: (i) generate an idea, (ii) record the idea i.e. through visual representations and (iii) decide whether to continue to generate more ideas or explore the existing ones. The stage that follows conceptual design is the 'embodiment of schemes' where selected design solutions are developed in greater detail. French points out that in most cases there is a great deal of feedback from this stage to the conceptual design stage sometimes making the boundaries between both stages not very clear. The last stage of the design process is the 'detailing stage' in which subtle, but no less important, shape features as well as colours and textures of the product are laid down.

Pahl and Beitz (1996) outlined a model of the design process for mechanical design that considers not only the sequence of stages, but also what the output of each stage should be, as they consider this to be a strategic guideline for design (Figure 7). They divided the design process into four phases as follows:

(1) Planning and clarification of the task:

Collect information about the requirement to be embodied in the solution and also about the constraint.

(2) Conceptual design:

Establishing the conceptual design by searching for working principles and selecting the suitable concept

(3) Embodiment Design:

Embodiment design through a fixed layout by means of a technical description

(4) Detail design:

Physical realisations through detail drawing consist of form, dimension, material specification and bill of materials.

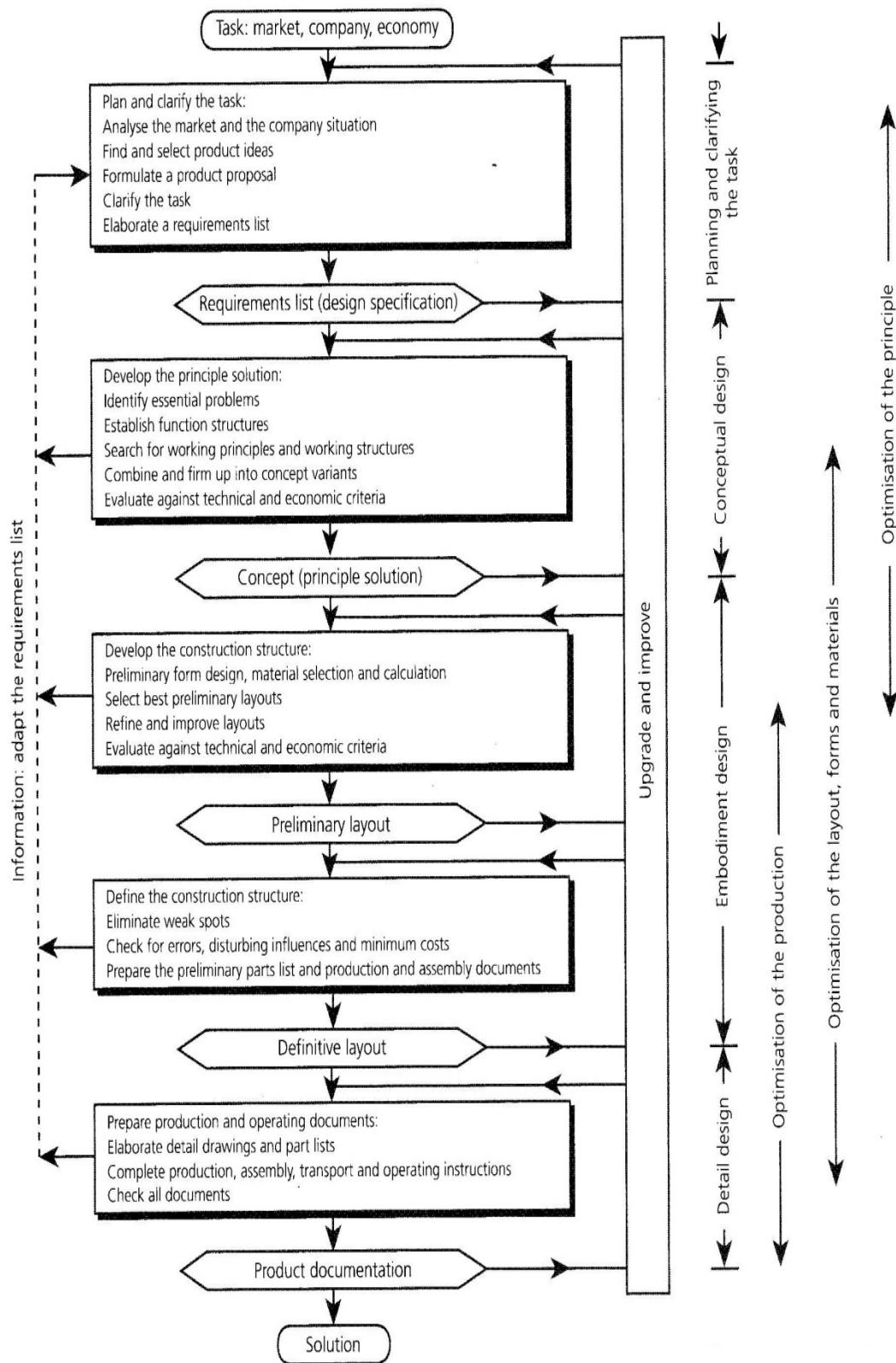

Figure 7: Pahl and Beitz's Model of the Design Process.
 (Pahl and Beitz, 1996)

Although many more design process models may be found in the literature most have converged upon the general form proposed by Pahl and Beitz's and French (Cross N, 1992). Other such examples may be found in (Pugh, 1991) and (Ulrich and Eppinger, 2004).

The German VDI 2221 (Figure 8), states guidelines for a more systematic approach for the design of technical systems and products. The VDI guideline follows a general systematic procedure of first analysing and understanding the problem as fully as possible, then breaking this down into sub problems, finding suitable solutions and combining these into an overall solution. This model has been criticised in the design world because it seems to be based on a problem focused rather than a solution focused approach. It therefore said to run counter to the designer's traditional ways of thinking (Cross 1989, p29).

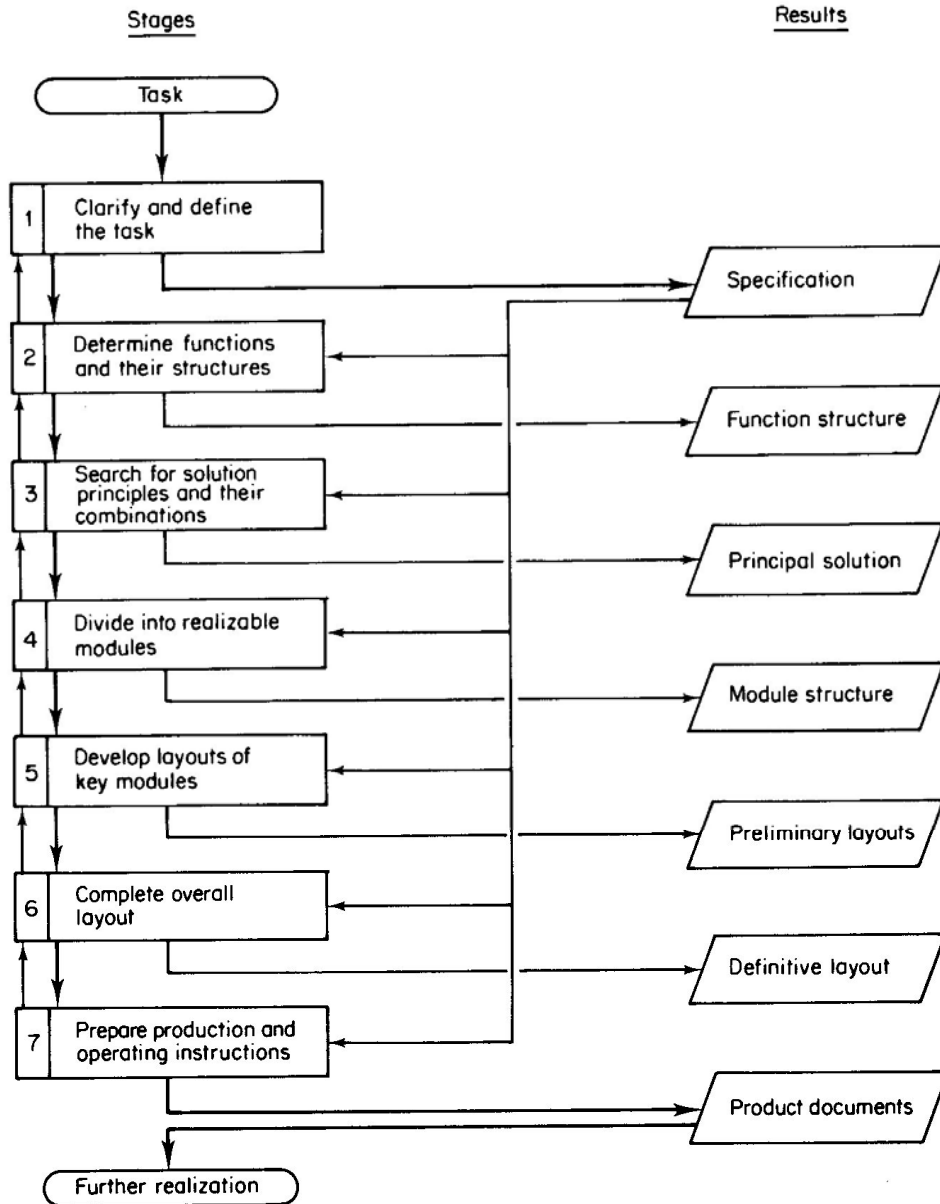

Figure 8: The VDI 2221 Model of the Design Process.
(VDI, 1987)

A more radical model of the design process has been suggested by March (1984) which recognises the solution focused nature of design. It is called the Production – Deduction - Induction model (Figure 9). He argued that the most commonly known forms of reasoning such as inductive and deductive reasoning are only suitable for the analytical type of design activity. However, design is mostly associated with synthesising for which there is no commonly accepted form of reasoning. In the model, he proposed a third type of reasoning, “productive reasoning” which is responsible for the creative activities of design.

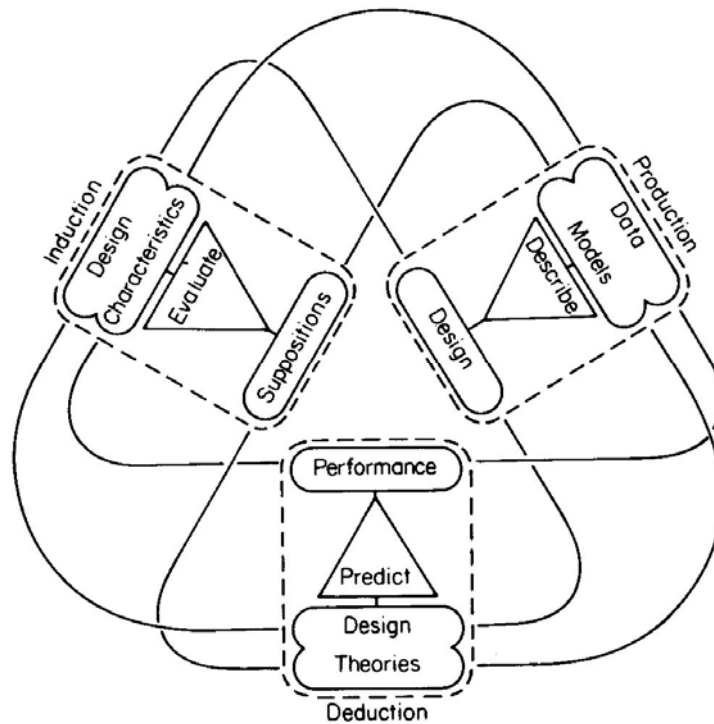

Figure 9: March's PDI Model of Reasoning in Design.
(March, 1984)

Design integration was demonstrated by Pugh (1991) and Ulrich (2004) who introduced integrative models of product design and development. The concept of Total Design, as introduced by Pugh (1991), is a systematic activity, from the identification of market/users need, to the selling of the product to satisfy that need that encompasses product, process, people organisation and also the emphasis of multi-disciplinary teamwork. Figure 10 shows the total design activity model which includes the design core containing the market or user need, the product design specification (PDS), conceptual design, detail design, manufacture and sales. From the statement of need the PDS has to be formulated to govern all the subsequent activities in the design core.

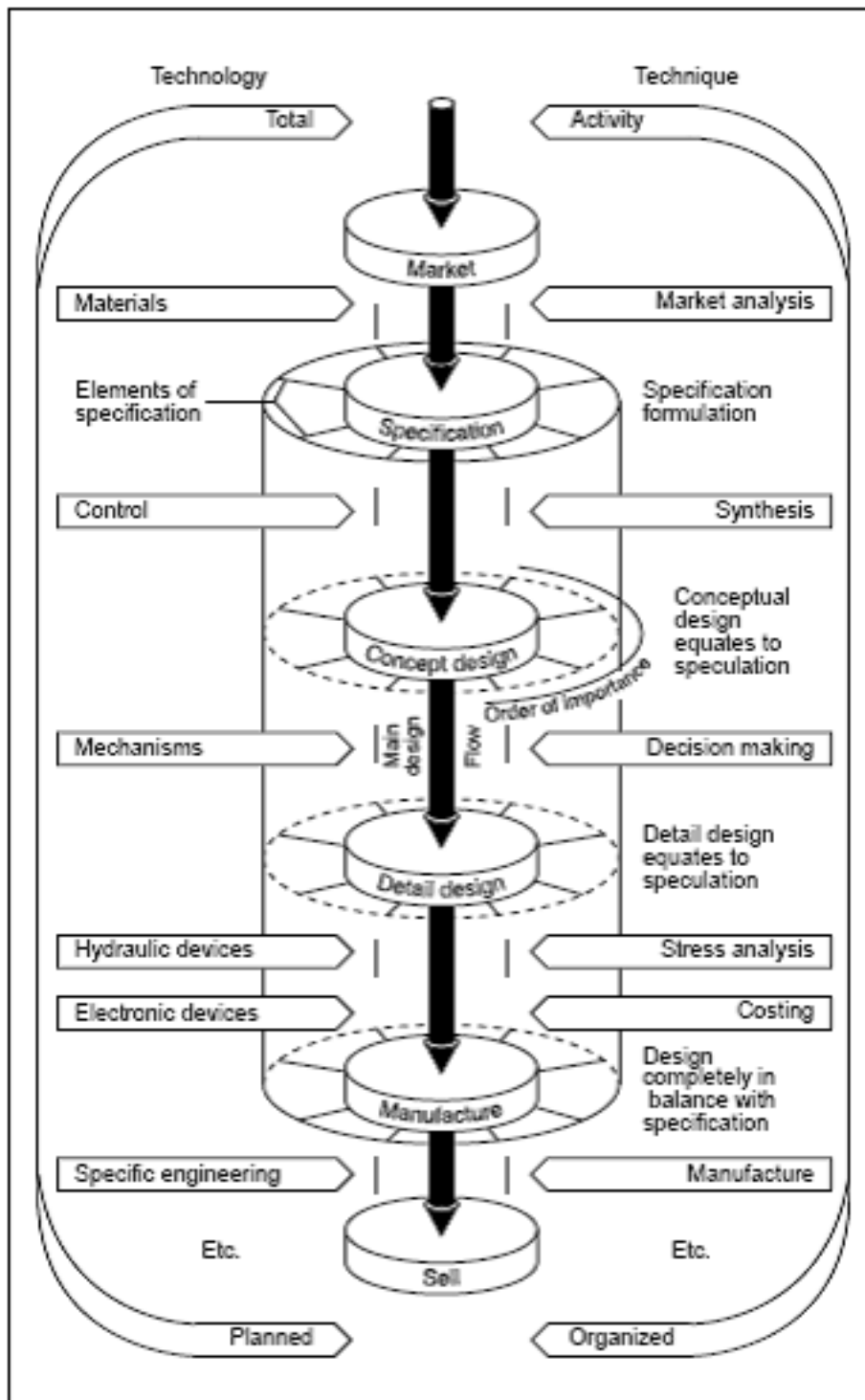

Figure 10: Pugh Model Showing Integration among Functions (Pugh, 1991)

Figure 11 shows 32 elements of a PDS that can envelop the design core. To enable designers to practise design effectively, they have to use systematic tools and techniques at each design core stage. These include techniques of analysis, decision making, modelling etc. that are applicable to any product or technology and are independent of discipline or technology. Pugh also believed that a successful product in the market requires the input from various personnel in an organisation that are familiar with other disciplines in order to have common objectives and to avoid misconceptions.

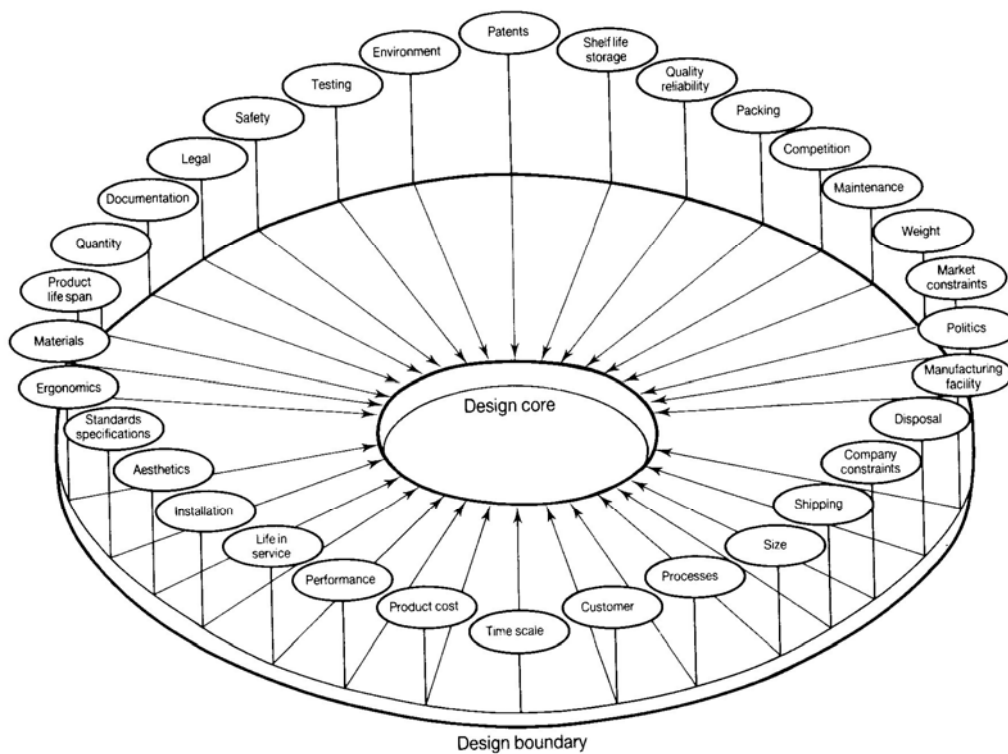

Figure 11: Product Design Specification.
(Pugh, 1991)

Figure 12 shows the generic product development process consisting of six phases. This figure also shows the key activities and tasks of the different functions of the organisation during each development phase. The process begins with a planning phase where the activity of articulating market opportunity begins. This will lead to the process of collecting the customers' needs, developing a business plan, marketing plan and promotional strategy. The output of the planning phase is the input to begin the concept development phase (Ulrich and Eppinger, 2004). The output of the concept development phase is one or more new design concepts that can be used as a basis for embodiment and detail design (Pahl and Beitz, 1996).The

final stage of a product development process is the activity of delivering the product to the market.

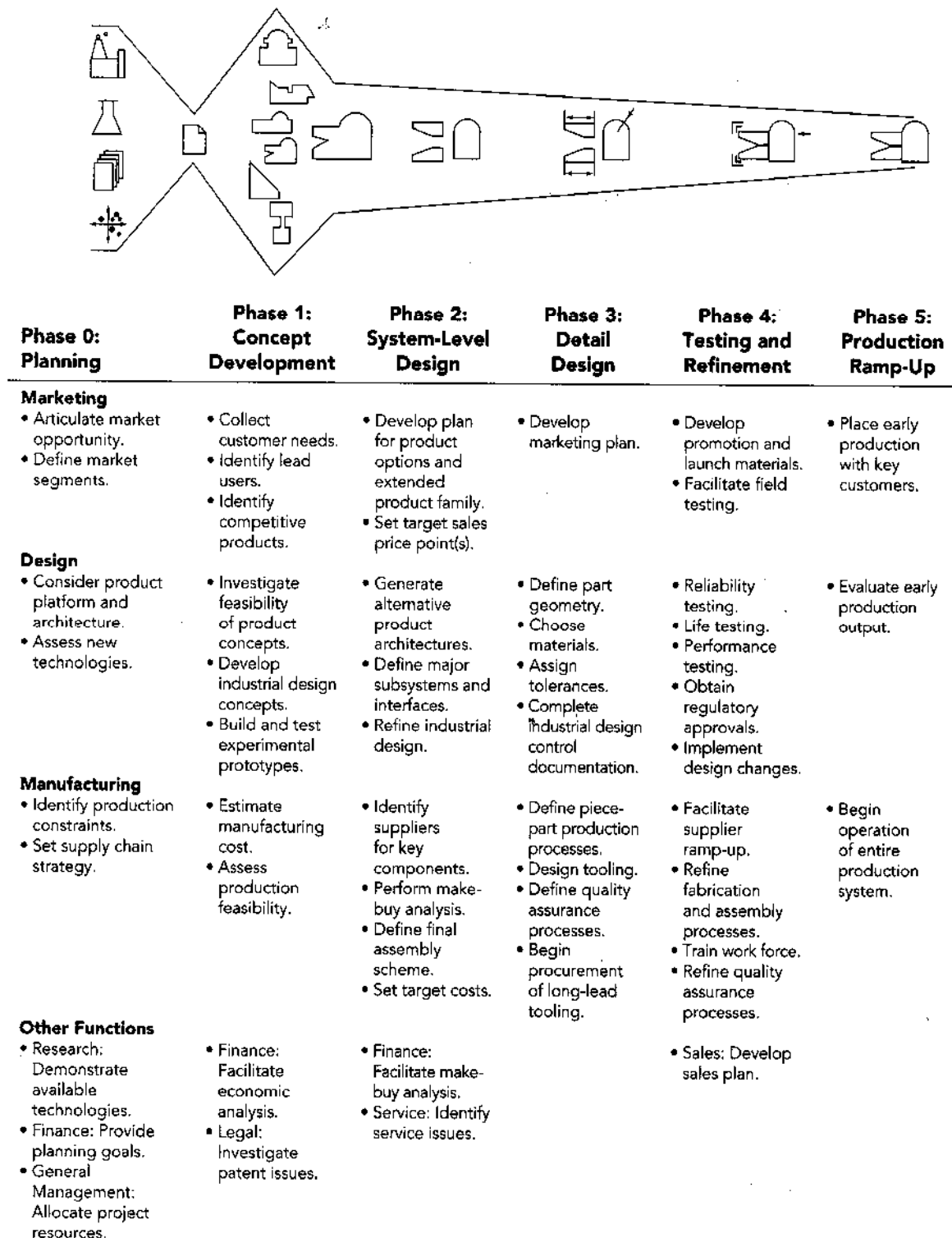

Figure 12: A Generic Product Development Process (Ulrich and Eppinger, 2004).

The survival of any manufacturing organisation is dependent upon its ability to introduce innovative products and services to the market quickly. New product development has thus become a key strategic activity in many firms as new products make an increasingly significant contribution to sales and profits (Koufteros and Marcoulides, 2006). Product development process is one of the most important activities of a manufacturing organisation (Marion and Simpson, 2009). The process of product development is highly complex and uncertain due to a demanding environment characterised by increased globalisation and segmentation of markets, increased levels of products complexity , changing customer needs and shorter product life cycles (BüyüKözkan et al., 2004). According to Ulrich and Eppinger (2004), *“a well-defined development process helps to ensure product quality, facilitate coordination among team members, plan the development project and continuously improve the process”*.

2.5 Stages of Design Activity

There have been several models to illustrate the stages of design process. However, the design activity within these models can be divided into three main stages: conceptual design, embodiment design and detailed design (Pahl and Beitz, 1996). However, this is not a universal approach used by all companies and designers.

2.5.1 Concept Design

The first important stage of the product development process is the concept design stage which is considered as the most critical stage (Ye and Campbell, 2006). This is because the knowledge of the design specification and constraints during this early stage of a product's life cycle are usually imprecise and not complete enough to satisfy the customer requirements from functional, economic, technological and service points of view (Chang et al., 2008). At this phase, science, engineering, technology and management knowledge are brought together when the most important design decisions are made.

It was found that most of the questions generated during the design process are related to the information relevant at the conceptual level of the design process (Tay and Gu, 2002). It is widely acknowledged that up to 75% of a product's total cost is dictated by decisions made during the conceptual design phase (Hsu and Liu, 2000). Decision made early at this stage have significant impact on other aspects of a product's life cycle such as quality, cost and manufacturability. It is usually difficult to compensate a poorly conceived concept with good detail design (Hsu and Liu, 2000).

A large portion of the conceptual design phase involves generating and clarifying ideas through searching, establishing and selecting suitable concepts against technical and economic criteria (Pahl and Beitz, 1996). Conceptual design stages often involve collaboration between customers, designers and engineers. Designers undertaking this stage of the design are often termed "industrial designers". Concept generation is limited to the experiences or creativity of the designer. The more experiences or past design knowledge available to the designer, the better the quality and variability of concept designs that can be generated (Kurtoglu et al., 2009). Often at this stage, designers will explore design solutions with pencil and paper to record quick and spontaneous new conceptual thoughts such as shown in Figure 13. The reason for this includes speed, low cost, it does not need special knowledge to sketch (as precision is not necessary to express an idea) and changes can be made easily.

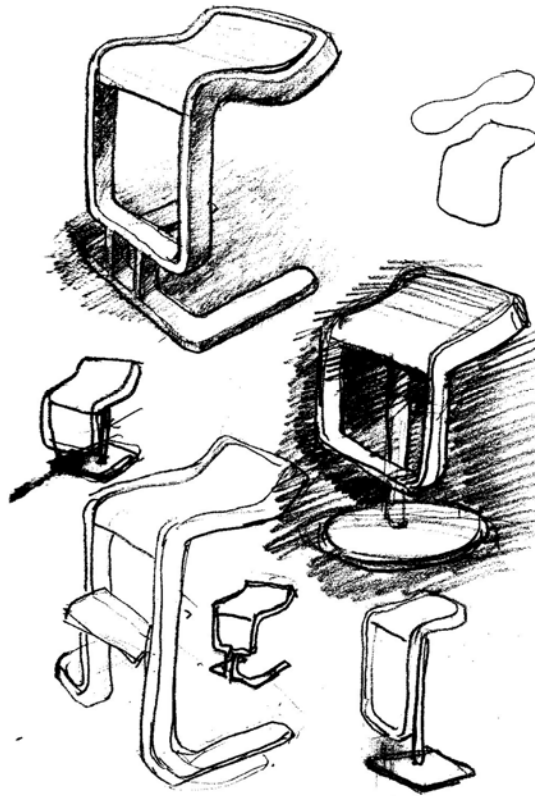

Figure 13: Concept Sketches for Exploring Ideas of a High Stool
(Pipes, 2007)

Computers have been used extensively in areas such as simulation, modelling and optimisation at the detail design stage. However, due to the highly complex and informal nature of information at the conceptual design stage, it still lacks suitable computer support (Chang et al., 2008), (Hsu and Liu, 2000).

The most common techniques used at the conceptual design stage include creative methods such as brainstorming or conventional methods such as patent searches or systematic methods using computer programs such as genetic algorithms, case based reasoning and agent technology (Wang et al., 2002). Conceptual design knowledge can also be obtained from experts or extracted from existing products (Brunetti and Golob, 2000). Figure 14 shows a classification of the techniques used for conceptual design based on the activities they are aiming at. This classification is a collection of methods and each of them has their advantages and disadvantages.

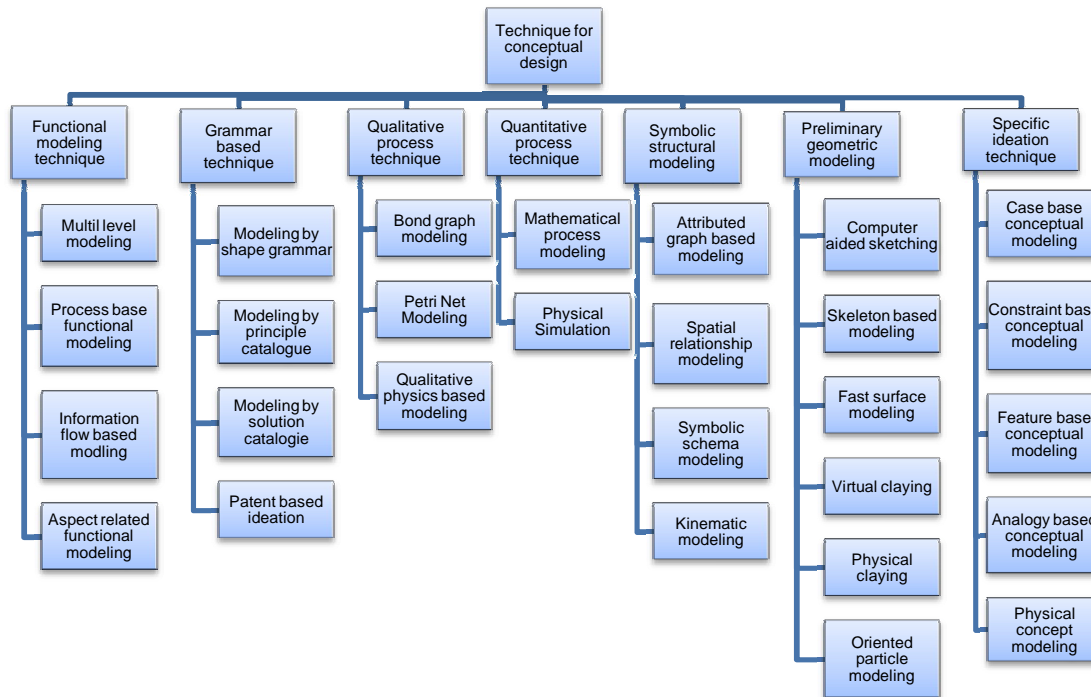

Figure 14: A Classification of the Conceptual Design Techniques (Imre, 2000)

It is important that designers have access to the right tools to support their design activities at this stage. Design activities consist of a number of decision making processes in every stage which requires many types of design information and knowledge. If the knowledge and information can be stored and retrieved systematically and can be processed to support the conceptual design process, the design process would become more efficient and the lead time required for the development of new product or parts could be substantially shortened (Ulrich and Eppinger, 2004). For this research, concept design is defined as the process of brainstorming and generating ideas based on specifications, functions and form with economic justification.

According to (Dahl et al., 2001), “*visualisation during design refers to the mental images used by the designer during the design process. Visualisation enables generation, interpretation and manipulation of design information*”. Visualisation enables designers to understand the design problem, develop design solutions to the problem and evaluate the potential solutions that have been developed (Roozenburg and Eekels, 1995). In addition, Roozenburg (1995) asserts that visualisation is of

critical importance during the conceptual design process. It has been suggested that visualisation enhances the ability to generate and configure new design concepts (Lorenz, 1990). However, despite these facts, little is known about methods, tools and techniques that provide visual examples to designers to aid the conceptual design process, particularly when designing for AM.

2.5.2 Embodiment Design

Embodiment design or system level design is the second important phase of the product development process. At this stage, designers often determine the overall layout of a technical system in line with technical and economical specification from the earlier conceptual design stage (Pahl and Beitz, 1996). The aim of this stage is to produce a well-defined form of the developed idea from the finalised conceptual design. The output of this phase usually includes a geometric layout of the product, a functional specification and a preliminary process flow diagram for the final assembly process (Ulrich and Eppinger, 2004).

Physical models and prototypes such as in Figure 15 are often used in this stage to define the developed arrangement and shape of the product. For this research, the embodiment design stage is to take the final product design concept and develops it further to include more information such as the dimensional and geometrical tolerances and then evaluates it against the technical and economical criteria.



Figure 15: An Appearance Model of a Desk.
Source :< <http://adesignmafia.com>> 18/10/2010

2.5.3 Detail Design

Detail design is the third important stage of product development process. The detail design phase includes the complete specification of the geometry, materials, and tolerances of all of the unique parts in the product and the identification of all of the standard parts to be purchased from suppliers (Ulrich and Eppinger, 2004). The outputs of this stage are the drawings describing the geometry of each part, the specifications of the purchased parts, and the process plans for the fabrication and assembly of the product (ibid). An example of an engineering design detail drawing is shown in Figure 16. For this research, the detail design phase is concerned with producing the final and complete detail of a product which includes the technical descriptions of each component such as the materials, surface properties, tolerances, positioning and assembly information, together with final testing before production.

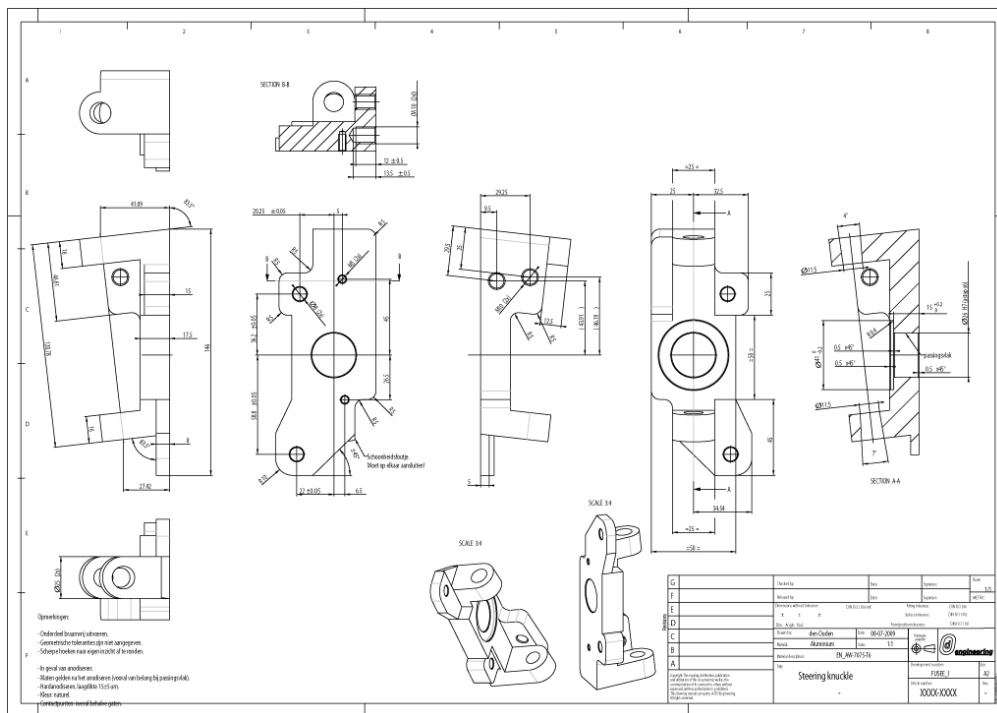

Figure 16: An Example of Engineering Design Detail Drawing.
Source :< <http://www.do-engineering.nl/engels/?services,2>>18/10/2010

2.6 Design Methods

According to Cross (2008), “design methods can be any procedures, techniques, aids or tools for designing”. Different design methods have different purposes and may be relevant and applicable to different aspects and stages of the design process. Some design methods have been criticised as being over-formalised and hence a hindrance to creativity (Cross, 2008). However, due to the complexity and nature of many processes of design that involve important decisions making, the use of proper design methods would still help towards a structured approach to reduce errors (Nigan, 2004). Table 3 shows some recommended methods that could be used during particular phases of the product development process.

Phase	Recommended Methods
Concept Development	Market Studies Voice of Customer House of Quality (QFD)
Embodiment Design	Function Analysis Design for Manufacture Design for Assembly & Disassembly CAD/CAM Simulation Optimisation 6-Sigma Analysis Additive Manufacturing Design for Environment & Service Failure Mode & Effects Analysis Robust Design Statistical Reliability Analysis Design for life Cycle
Detail Design	Workplace Design Flexible Automation Tools Value Stream Mapping

Table 3: Recommended Product Development Methods
Adapted from: (Shetty, 2002).

Jones (1992) proposed classifying design methods into two categories: divergent methods and convergent methods as shown in Table 4. Divergent methods are used to explore possibilities through the use of qualitative and quantitative techniques to arrive at better design solutions. Convergent methods are used to achieve better design solutions using evaluation. To further contribute to the models proposed by Jones, Gupta and Murthy (1980) added transformation methods as a third category. The transformation methods consist of techniques to enhancement creativity.

Convergence methods (Evaluation)	Transformation Methods (Searching for ideas)
Boundary Searching CASA (collaborative strategy for adaptable architecture) Checklists Design review DFMA (Design for manufacture and Assembly) FCA (Function Cost Analysis) FMEA (Failure Mode & Effect Analysis) QFD (Quality Function Deployment) Ranking & Weighting Specification Writing Systematic Search Systems Engineering Taguchi / Robust Design Value Analysis	6-3-5 Method AIDA (Analysis of Interconnected Decision Areas) Block Models CAD (Computer Aided Design) Continuous Solutions Contrasting Solution Crating C- Sketch Frame Models Function Means Tree Image Boards Models Kits Mood Boards Morphological Charts Pair Wise Comparison Charts Props Quick Sketching Removing Mental Blocks Test Models The gallery Method Three Dimensional Modelling Thumbnails
Divergence Methods (Exploring Design Situations)	
Fundamental Design Method Literature & Patent Search Problem Decomposition Requirement Tress Reverse Engineering SWOT Analysis Synectics	

Table 4: Classification of Design Methods.
Adapted from: (Gupta and Murthy, 1980)

While Jones (1992) classify design methods into two categories namely divergent methods and convergent methods, Gouvinhas (1998) has made an attempt to further categorise design methods into three broad categories: design methods for the generation of ideas for concept design, design methods for concept design evaluation and design methods for a specific design purposes, which aims to aid designers in improving their design, for example, ease of manufacture and assembly and improved quality and cost. Table 5 shows these three groups of design methods and their respective examples.

Design Methods	Examples
1. Generation of ideas for concept design	Brainstorming, Fish bone diagram
2. Concept design evaluation	Pugh's Matrix, Morphological Chart, Checklist, Weighting and Rating, Combinex Method
3. Specific design purposes	Design for Assembly, Design for Manufacture, Quality Function Deployment, Failure Modes and Effect Analysis, Taguchi Methods, Functional Analysis Method, Function-Cost-Method, Design for Cost, Value Engineering, Activity Based Costing

Table 5: Category of Design Methods.
Adapted from: (Gouvinhas, 1998)

Comparing to Gouvinhas, Cross (2008) has proposed categorising design methods into a simplified two groups that are creative or rational (Table 6). Generally, the purpose of creative methods is to promote creativity by removing mental blocks and the purpose of rational methods is to support most aspects of the design process. However, both these methods complement each other. These methods, tools, techniques and strategies may also serve multiple purposes and may be used at several design stages. This research will attempt to contribute to the first group of design methods for idea generation.

Design Methods	Example	Purpose
Creative Methods	Brainstorming Synectics Enlarging the search space The creative process	To provide ideas or inspiration by removing mental blocks that obstruct creativity and by widening the search space
Rational Methods	Checklist User scenarios method Objectives tree methods Functions Analysis Methods The performance specification methods QFD method Morphological Chart Weighted Objectives Method Value Engineering Method	To avoid error and improve decision making process in product development process.

Table 6: Creative and Rational Methods
Adapted from: (Cross, 2008)

2.7 Design Media

There are various methods, tools and techniques used by designers to support the design activity. This section describes some of the most important methods, techniques and tools.

2.7.1 Sketching

According to Pipes (2007), a sketch is a collection of visual ideas to suggest and explore design alternatives to an observer. Design sketching is an important aspect of the conceptual stage of the new product development process (Cross, 2008), (Pipes, 2007). Sketches often act as method of generating ideas that could later be refined to generate new ideas (Jonson, 2005). Sketching is a process often used by engineers and designers to explore and communicate mental concepts that come about in their mind during the conceptual design stage (Menezes and Lawson,

2006). The act of sketching is a means of communication and attracting attention as well as providing a medium for storing information (Tang, 1991).

Sketches can include informal freehand marks consisting of draft lines, text, dimensions and calculations that help explain the meaning, context and scale of the design (Duff and Ross, 1995). As sketches are informal, quickly and easily changed and less restrictive, they are important during the early stages of the design process. After clarifying the design concept through several freehand sketches, CAD drawing becomes more useful at the later stage of the product development process (Tovey et al., 2003). An example of a freehand sketch from the helicopter inventor Igor Sikorsky is shown in Figure 17 demonstrates the visual impact of freehand sketching.

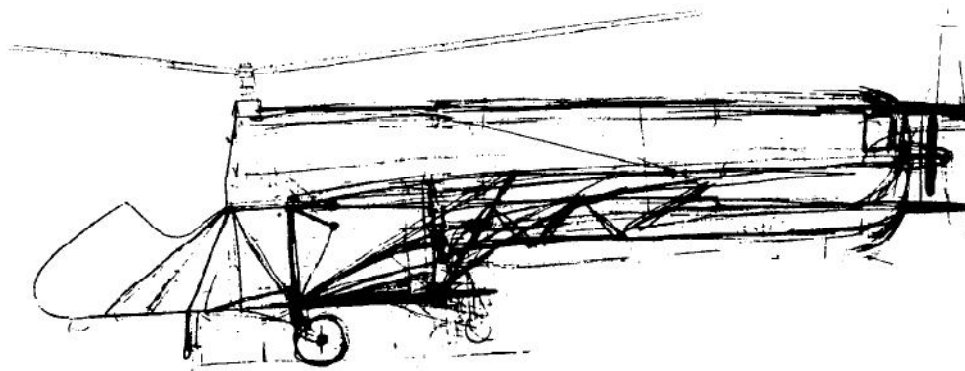

Figure 17: Sketch of an early helicopter prototype (Wohleber, 1993)

In classifying sketches, (Ferguson, 1992) identifies three groups of sketches as:

- i. Thinking sketches refer to the designers making use of the sketch in support of their individual thinking processes
- ii. Talking sketches refer to the designers making use of the sketch in a group discussion.
- iii. Prescriptive sketches refer to the designers communicating design decisions to a drafter to make a finished drawing or to a machinist for a machining process.

According to Van Der Lugt (2005), sketching provides a means to store design ideas so that they can be revisited later. He refers to this category of sketch as storing sketches. Alternatively, Olofsson & Sjölen 2005, grouped sketches into four groups as:

- i. Investigative sketches for problem definition
- ii. Explorative sketches for generating and evaluating solutions
- iii. Explanatory sketches to describe and communicate the design
- iv. Persuasive sketches for selling an idea.

Table 7 shows the classification of the types of sketches according to their purpose that has been described above.

Purpose	Sketch Group by Ferguson (1992), (van der Lugt, 2005)	Sketch Group by Olofsson & Sjolen (2005)
Problem solving	Thinking sketches	Investigative sketches
Providing instructions	Prescriptive sketches	-
Describe and communicate the design	Talking sketches	Explanatory sketches
Retain ideas	Storing sketches	-
Generating and evaluating solutions	-	Explorative sketches
Selling an idea	-	Persuasive sketches

Table 7: Classification of Sketch Groups

Thinking sketches or investigative sketches have been used by designers as an aid to conceptual design (Company et al., 2009). Figure 18 shows an example of a thinking sketch of an iron. The text annotation was added to the sketch to ensure that new thoughts and ideas which arose during the sketching process were not forgotten.

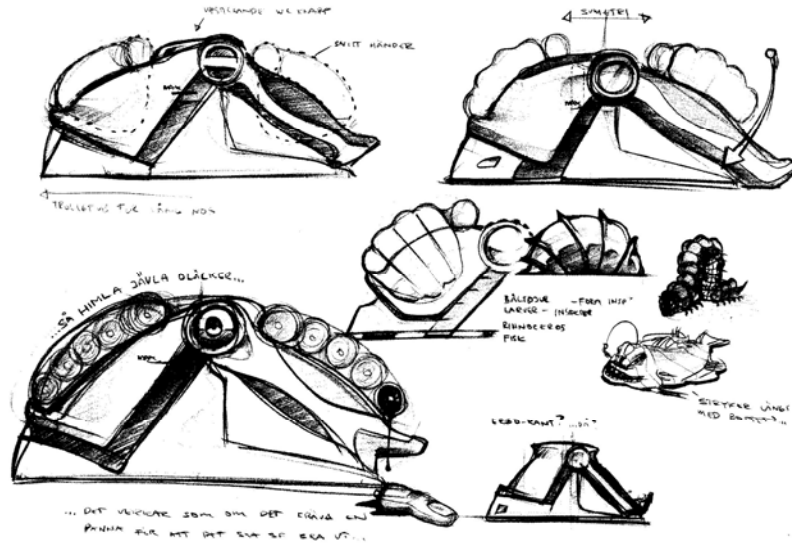

Figure 18: An investigative sketch of an iron (Olofsson et al., 2005)

According to Company (2009), prescriptive or storing sketches are technical drawing that contains detailed information describing a final design (Figure 19). According to Pipes (2007), prescriptive sketches are created during the development stages of the design process prior to a more detailed general arrangement drawing.

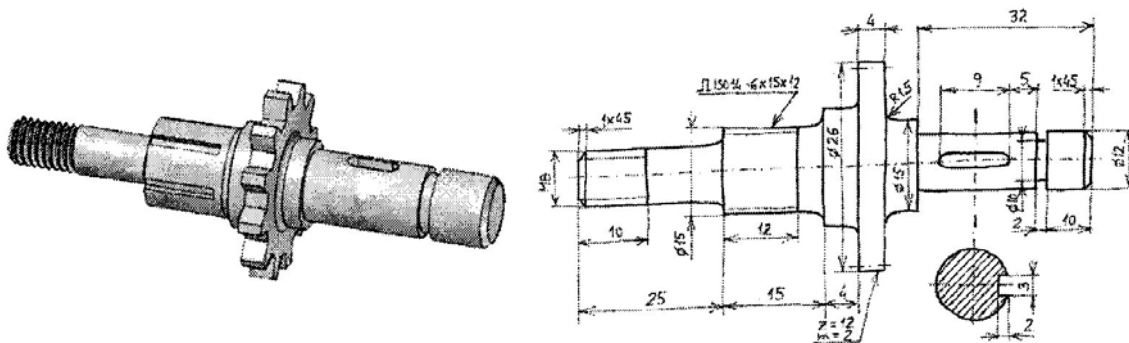

Figure 19: A 3D model of a shaft and its prescriptive sketch (Company et al., 2009)

According to Olofsson & Sjolen (2005), talking sketches or explanatory sketches are created to explain functions, structure and form (Figure 20). They are used in group discussions to present a number of concepts for users and clients to evaluate the idea.

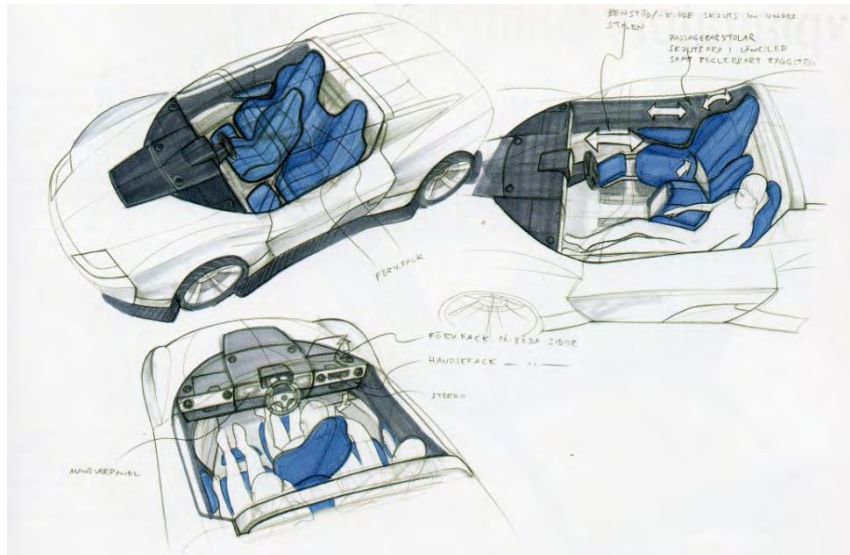

Figure 20: An explanatory sketch of the interior of a sport car (Olofsson et al., 2005)

An exploratory sketch of a truck design in Figure 21 shows sketches of an idea being explored to determine the identity of a certain truck brand and its form from various views.

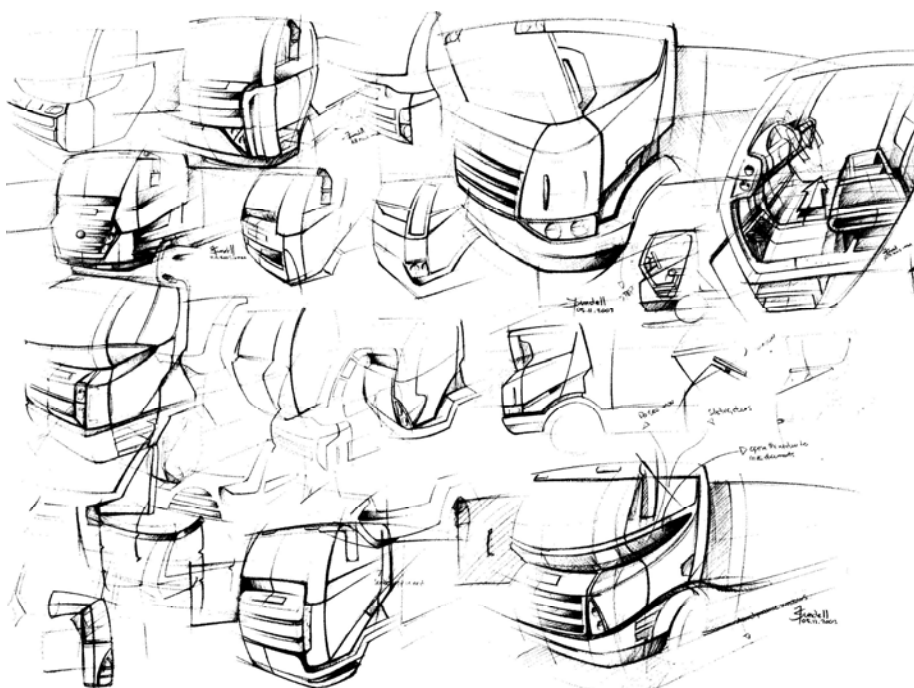

Figure 21: An exploratory sketch of a truck (Olofsson et al., 2005)

According to Olofsson & Sjolen (2005) a persuasive sketch, as shown in Figure 22, explains the product, influences the audience and sells a design concept.



Figure 22: A persuasive sketch of a goggle
(Olofsson et al., 2005)

2.7.2 Drawing

Drawing is an important element in the industrial design process, facilitating visual thinking and creativity (Tovey, 1989). Drawing is the modelling of properties of a design (e.g. structure, form, material, dimension, surface, etc), coded in terms of symbols (e.g. coordinates, graphical symbols, types of projections) (Tjalve et al., 1979). Drawings are geometric representations of an idea or product that can be manufactured. Engineers, designers and drafters use drawings to communicate technical information to each other and from the design office to the manufacturing floor.

In classifying drawings, (Pei, 2009) proposed classification of drawings into two groups. The first group is industrial design drawings which include concepts drawings, presentation drawings, scenarios and storyboards. As shown in Figure 23, a concept drawing is a 2D visual design representation that shows the design proposal in colour within an orthographic view.



Figure 23: Concept Drawing of Audi Sport back
Source :< www.seriouswheels.com> 25/10/10

Presentation drawings using markers and pencils, as shown in Figure 24 are used to sell an idea and to instil confidence within the client.



Figure 24: A presentation drawing of a Concorde seats
(Pipes, 2007)

Scenarios and storyboards, as shown in Figure 25, are used to explain a concept by setting a product within its environment. The second group of drawings, according to Pei (2009), are engineering design drawings which include 2D visual design representations of single or multiple view drawings, technical drawings and technical illustrations (Figure 26).

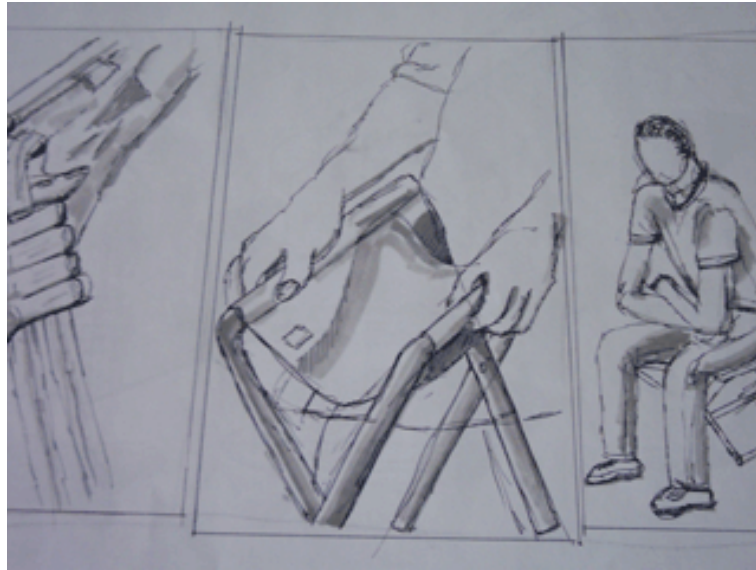

Figure 25: A scenario of folding and sitting on a folding chair
 Source :< <http://www.yvettedijkhuizen.nl/drawing.html>> 25/10/10

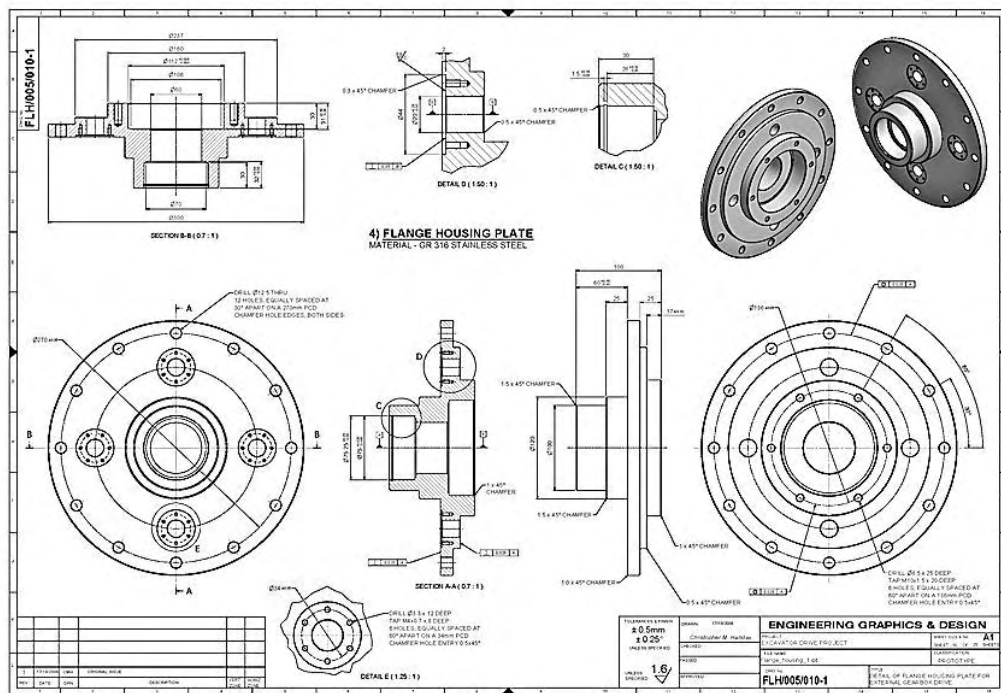

Figure 26: An example of Engineering Drawing of a Flange Housing.
 Source :< www.engd.com.au> 25/10/10

2.7.3 Models

Physical models are non-functional objects used to describe the visual appearance of a product (Holmquist, 2005). They are often used as a means in conceptual design stages by which designers or engineers can understand in depth a product design concept besides referring to sketches or drawings (Johan et al., 2009). Physical models allow designers or engineers to explore the function, performance and aesthetics of a product design. The use of physical models has also been seen as a means of supporting communication and improving designers' creativity (Tovey, 1989). However, some models are more suitable for communicating information while others are more suited to testing ideas (Johan et al., 2009).

In terms of classification, (Vervis, 1994) grouped models into two groups i.e. industrial models and engineering models. Industrial models are 3D visual representations that are seen as being concerned with structural or aesthetical aspects in a tangible form. However, the engineering models can be a 3D representation of a final product design showing its functionality or performance. According to Pei (2009), industrial models comprise 3D sketch models, design development models and appearance models. As shown in Figure 27, 3D sketch models are tangible medium representations used to explore a potential idea and to obtain a visual appearance that are often made with soft material such as foam. A design development model will be made upon confirmation of a design concept.



Figure 27: A 3D sketch model made from foam.
Source :< www.confluencecreative.co.uk > 25/10/10

To enhance realism the use of readymade working parts, paints and various geometrical shapes can be added to a product model as shown in Figure 28.



Figure 28: A design development model made with clay of a motorbike.
Source :< www.coroflot.com > 25/10/10

An appearance model (Figure 29) is concerned with the external look and not the functionality of a product as defined in (Baxter, 1995). AM systems that will be described in detail in Chapter Three have been commonly used to produce appearance models.



Figure 29: An appearance model of a boom box.
Source :<www.cyclestart.com>25/10/10

According to Pei (2009), engineering design models are 3D visual representations used to represent the technical aspects of a product that show the moving parts.

Engineering design models comprise functional concept models, concept of operation models, production concept models, assembly concept models and service concept models (ibid). The most important engineering design model is the functional concept model, also known as principle models (Evans, 1992), that is used to prove the functionality of a product concept. The Cycleton One bike (Figure 30) is a functional concept motorcycle designed by Daniel Yorba. It was displayed at the Art Center College of Design in Pasadena, California in August 2010.



Figure 30: A functional concept model of a motorcycle.
Source :< www.illusion.scene360.com > 26/10/10

2.7.4 Prototypes

Prototypes can reduce design risk without committing to the time and cost of full production (Ulrich and Eppinger, 2004). Prototypes answer various questions about the design concept of a product such as its performance, its mechanical properties, its fabrication issues, its assembly issues, etc. Traditionally prototypes are made by machining processes, casting and moulding. However, AM and virtual prototyping (which represents a design concept through computer simulation) are both used extensively nowadays to produce prototypes (Yang, 2005).

According to Dieter (2009), prototypes are physical models of the product that are tested to validate the final design decision to clarify the production and technical issues. According to Holmquist (2005), a prototype consists of functional parts and

does not resemble a final product that could be used for customers' perception evaluation. Evans (1992) defines a prototype as a full scale representation of a final product. Prototypes come in various forms and are used at various stages in the product development process.

AM has been commonly used to produce prototypes and finished parts directly from CAD models and has been used extensively in the embodiment design stage to check form, fit and function (Dieter and Schmidt, 2009). Industrial designers use prototypes to access the aesthetic, ergonomic and emotional aspects of a product concept, whereas engineering designers use prototypes to test and analyse the technical and functional aspects of a final design. Ullman (2002) described four classes of prototypes based on their function and stage in product development:

- i. A proof of concept prototype is used in the initial stages of design to understand the best approach to take in designing a product.
- ii. Later, a proof of product prototype clarifies a design's physical embodiment and production feasibility.
- iii. A proof of process prototype shows that the production methods and materials can successfully result in the desired product.
- iv. Lastly, a proof of production prototype shows that the manufacturing process is effective.

Pei (2009) has grouped prototypes into industrial design prototypes and engineering design prototypes. Industrial design prototypes are 3D visual design representations of the final form, ergonomics and aesthetics aspect of the final product design. Industrial design prototypes consist of appearance prototypes, alpha prototypes, beta prototypes and pre-production prototypes (ibid). Appearance prototypes, as shown in Figure 31, show the geometry and the functional component of a final product of a camera and could also be painted to represent the material and surface properties of the final product.



Figure 31: An appearance prototype of a camera.
 Source :< <http://nicmarks.com/>> 26/10/10

At the embodiment design stage, the alpha prototypes, as shown as in Figure 32, will be made to incorporate the assembled parts, the materials and the geometry that would resemble the actual product (Dieter and Schmidt, 2009). After five years of development, on January 2010 Cannondale Bicycle Corp unveiled a new alpha prototype that has one-legged shock forks that could revolutionise bicycle suspension. Called Simon, the bike has an onboard microprocessor that will allow users to customise their ride by choosing between one of five suspension modes.



Figure 32: Alpha prototype of a single fork bike shock absorber.
 Source :< www.gizmag.com> 26/10/10

At the detail design stage, the beta prototypes constructed in the same way as the alpha prototypes involve full size functional parts or product testing using the materials and processes similar to the final product and hence contain more details (Dieter and Schmidt, 2009). Figure 33 shows the AmphiCoach GTS-1, an amphibious passenger coach that was designed by Scotsman George Smith and built in Malta. The final prototype was tested at Marsaxlokk Bay, Malta on March 2009.



Figure 33: Beta prototype of amphibious passenger coach.
Source :< [www. busworld.org](http://www.busworld.org)> 26/10/10

According to Pei (2009), engineering design prototypes are 3D visual representations that are used to validate and refine the functional and technical aspect of the final design and may not display the final appearance of the design. They may contain the actual material, assembled parts and the enclosure for the electrical, electronic and mechanical components. Engineering design prototypes consists of experimental prototypes, system prototypes, final hardware prototypes, tooling prototypes and off tool prototypes (ibid).

Experimental prototypes do not resemble the final product but they allow engineers or users to evaluate, analyse, obtain feedback and improve the mechanical properties and performance of a product (Ulrich and Eppinger, 2004). The “Rider” (Figure 34) is an example of an experimental prototype of a three-wheeled electric

commuter scooter that can be folded and carried. It tilts slightly when turning corners and it can run for 4 hours at 15 kph (9.5 mph) on its 24 volt battery.



Figure 34: An experimental prototype.
Source :< treehugger.com> 27/10/10

According to Evans (1992) a system prototype (Figure 35) integrates various working components or parts of the product into a system allowing engineers to test, analyse and improve the function of a final product. The final hardware prototype does not represent the aesthetics or enclosure for a product but it does integrate the final working parts as a whole for engineers to analyse the fabrication and assembly issues that may arise.



Figure 35: System prototype of a propulsion unit.
Source :< http://heritageconcorde.com/?page_id=626>27/10/10

According to Evans (1992) tooling prototypes (Figure 36) are a representation of the final tooling that will be made for casting, forging or machining processes. They are made to reduce errors as they are very expensive and costly to modify later.

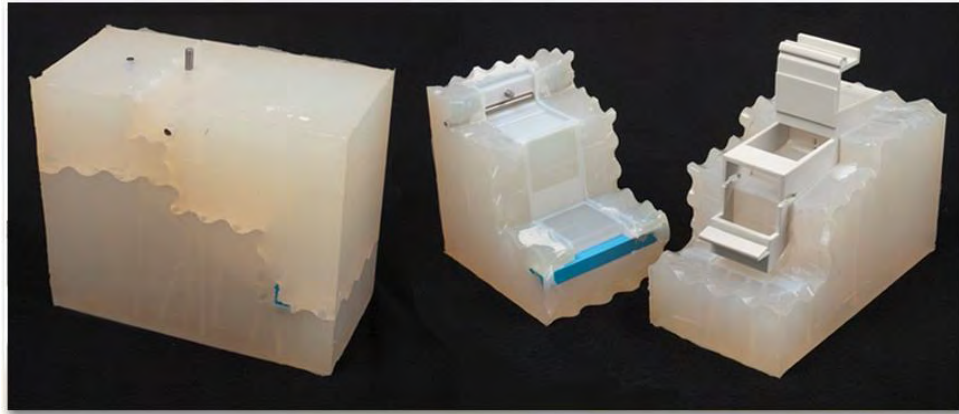

Figure 36: Tooling prototype for a consumer product
Source :< <http://www.p1technology.com/prototyping.aspx>>27/10/10

An off tool prototype (Figure 37) is made from the actual tooling and materials intended for the final product and it is used to test the fit , assembly issues or the finishing of parts Evans (1992).



Figure 37: Off-tool prototype for a consumer product
Source :< <http://www.prototypingrapid.com/page/1042348>>27/10/10

2.8 Decision Support Systems for Design

Computational tools play an essential role in providing support for the designer because of their speed and capability for handling huge amounts of information at fairly low cost (Tseng and Huang, 2008). Most design tasks and activities involve decision making concerning issues such as function, structure, configuration, material and geometry of the designed product (Saridakis and Dentsoras, 2008). This section describes briefly some of the most important approaches used in decision support in engineering and product design.

2.8.1 Expert Systems

Most of the decision support tools which are related to knowledge based systems are often called expert systems (Ziemian and Crown, 2001). Expert systems are computer programs that are derived from a branch of computer science research called Artificial Intelligence (AI). AI's scientific goal is to understand intelligence by building computer programs that exhibit intelligent behaviour (Boyle, 1989). It is concerned with the concepts and methods of symbolic inference, or reasoning, by a computer, and how the knowledge used to make those inferences will be represented inside the machine (ibid). However, according to Saridakis and Dentsoras (2008), AI is still not widely used in CAD/CAM systems because the difficulty to deploy several AI techniques in a concurrent and collaborative framework, the increase demand in computational power and the need to address the issues of conceptualisation, visualisation and detailed representation.

An expert system is software that uses human knowledge to solve problems that normally would require human intelligence, most commonly in a specific problem domain (Jamshidi, 1997). Such a program generally uses rules of thumb (heuristics) and symbolic logic to mimic the thought processes of a human expert. Building an expert system is sometimes known as knowledge engineering. The role of a knowledge engineer includes (ibid):

- a) Knowledge acquisition from human expert by interviews, books, manuals etc.
- b) Knowledge elicitation or representing. Common method uses cases, rules or frames.
- c) Encoding the knowledge acquired for the use by the expert system.

Typical applications of experts systems are medical diagnosis, financial analysis & factory production scheduling. Figure 38 shows a typical expert system structure.

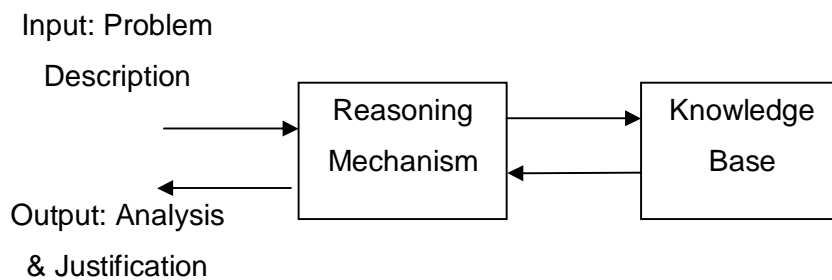

Figure 38: A Basic Structure of Expert Systems.

Every expert system consists of two principal parts: the knowledge base; and the reasoning mechanism or inference engine. The knowledge base contains domain knowledge, normally provided by human experts. It is typically very specialised for a particular problem domain. It is often encoded as IF-THEN rules and may incorporate heuristics or probabilities and it is usually a set of text files. The inference engine works by selecting a rule for testing and then checking if the conditions for that rule are true. The reasoning mechanism takes descriptions from the user about the problem to be solved. It can also request additional information as needed and interprets the knowledge base to make inferences, draw conclusions and ultimately give advice while explaining its reasoning to the user.

Rules are probably the most common form of knowledge representation and they are present in most AI applications such as expert systems and decision support systems (Obot and Uzoka, 2009). Rule based systems use rules as the knowledge representation for knowledge coded into the system. Rules typically take the form of if – then statement. Knowledge is stored as rules. To create a rule base system for a given problem the following must be created (ibid):

- (a) A set of facts to represent the initial working memory. This should be anything relevant to the beginning state of the system.
- (b) A set of rules. This should encompass any and all actions that should be taken within the scope of a problem, but nothing irrelevant. The number of rules in the system can affect its performance.
- (c) A condition that determines that a solution has been found or that none exists. This is necessary to terminate some rule base systems that find themselves in infinite loops.

Rules can be interpreted easily and enable modular systems to be built and a lot of human reasoning expressed as rules (McGarry et al., 1999). Rule base systems are really only feasible for problems for which any and all knowledge in the problem area can be written in the form of if-then rules and for which this problem area is not large. If there are too many rules, the system can become difficult to maintain and can suffer a performance hit (ibid).

The main characteristics of expert systems can be briefly described as: reduced decision making time, enhancement of problem solving capabilities, a capture of limited expertise and its diffusion, an increased output, productivity and quality; accessibility to knowledge, ability to work with incomplete information and provision of training (Wang and Wang, 2005). Despite these advantages, expert systems have also some limitations such as lack of maintenance of the information used and the lack of sophistication and the fact that they are only applicable to a very specific application (ibid).

A variety of tools can be used for building expert systems. Conventional programming languages, such as Pascal and C have sometimes been used. However, building expert systems from scratch with the above tools is very time consuming because the builder has to develop the user interface and implement an appropriate inference engine. Therefore, software programs called "expert system shells" are mostly used nowadays.

2.8.2 Case-Based Reasoning

Case-Based Reasoning (CBR) is a problem solving technique based on the adaptation of previous examples that are similar to the current problem (Maher et al., 1995). CBR can mean adapting old solutions or cases to solve or explain new cases. CBR has now become a mature and established technology with good availability of tools to build CBR systems and the accumulated practical experience of applying CBR techniques to real-world problems (Díaz-Agudo et al., 2007). However, CBR tools for design reuse do not offer much support at the conceptual design stage, since their usefulness is mainly at the detailed design stage by which time 80% of product costs are fixed (Baxter et al., 2008).

Figure 39 illustrates the CBR principle. The main explanation underlying CBR systems is based on the fact that human problem solving uses analogical reasoning or experiential reasoning to learn and solve complex problems. This argument provides some advantages for CBR systems compared to expert systems, such as not needing an explicit domain model and identifying only important features that describe a case. Furthermore, CBR systems use actual past experiences to learn and solve new problems, rather than generalised heuristic rules, as in expert systems (Moore and Lehane, 1999), (Yau and Yang, 1998), (Yoon et al., 1993).

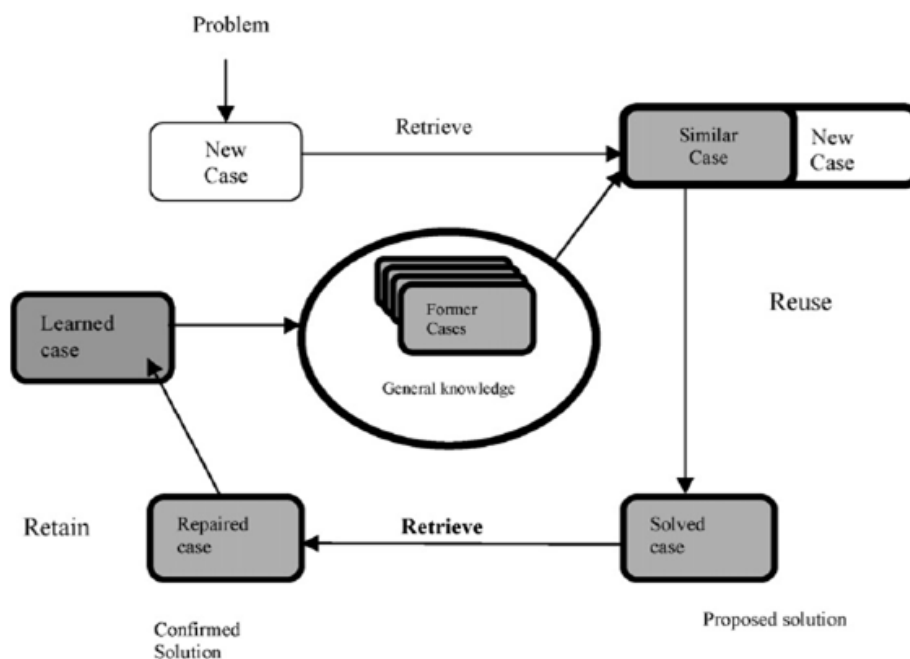

Figure 39: A typical case base reasoning cycle.
(Aamodt and Plaza, 1994)

The CBR working cycle can be described best in terms of four processing stages (Maher et al., 1995):

1. **Case retrieval:** after the problem situation has been assessed, the best matching case is searched in the case base and an approximate solution is retrieved.
2. **Case adaptation:** the retrieved solution is adapted to fit better the new problem.
3. **Solution evaluation:** the adapted solution can be evaluated either before the solution is applied to the problem or after the solution has been applied. In any case, if the accomplished result is not satisfactory, the retrieved solution must be adapted again or more cases should be retrieved.
4. **Case-base updating:** If the solution was verified as correct, the new case may be added to the case base.

In 1990s, case base design has been employed and proposed in several systems to provide design support particularly in architecture, however these systems have shown a limited success due to the complexity to retrieve, adapt, evaluate and update the design cases (Heylighen and Neuckermans, 2011). CBR relies on the knowledge stored in the case base library since learning from experience is the essential element of CBR approach. When the number of cases is small, it could be difficult to use CBR to solve problems. According to Bernard et al. (2003), two main disadvantages of CBR when applied to a very fast moving field such as AM, is that the coherent number of process case studies must be very significant in order to allow the system to find solution to the user specification. Furthermore, innovation is difficult to integrate due to the lack of experience (ibid).

2.8.3 Fuzzy Logic

Fuzzy systems are developed using the method of fuzzy logic, which deals with uncertainty. This technique uses the mathematical theory of fuzzy sets, simulates the process of normal human reasoning by allowing the computer to behave less precisely and logically than conventional computers (Shu-Hsien, 2005). This approach is used because decision-making is not always a matter of true or false; it

often a subjective matter. Accordingly, creative decision-making processes can be characterised as unstructured, playful, contentious, and rambling (Jamshidi, 1997). In engineering design, fuzzy logic has been applied in various domains such as the design of comfort systems (heating, cooling, ventilation, shading) (Dounis et al., 1995), the design of machining activities (Chen et al., 1995), the preliminary design of vehicle structure (Scott and Antonsson, 1998) and the conceptual design of robot gripper (Moulianitis et al., 2004).

2.8.4 Artificial Neural Networks

Artificial Neural Networks (ANN) is an information processing paradigm that is inspired by the way biological nervous systems, such as the brain, process information (Moridis and Economides, 2009). The key element of ANN is the information processing system. It is composed of a large number of highly interconnected processing elements (neurons) working in unison to solve specific problems as shown in Figure 40.

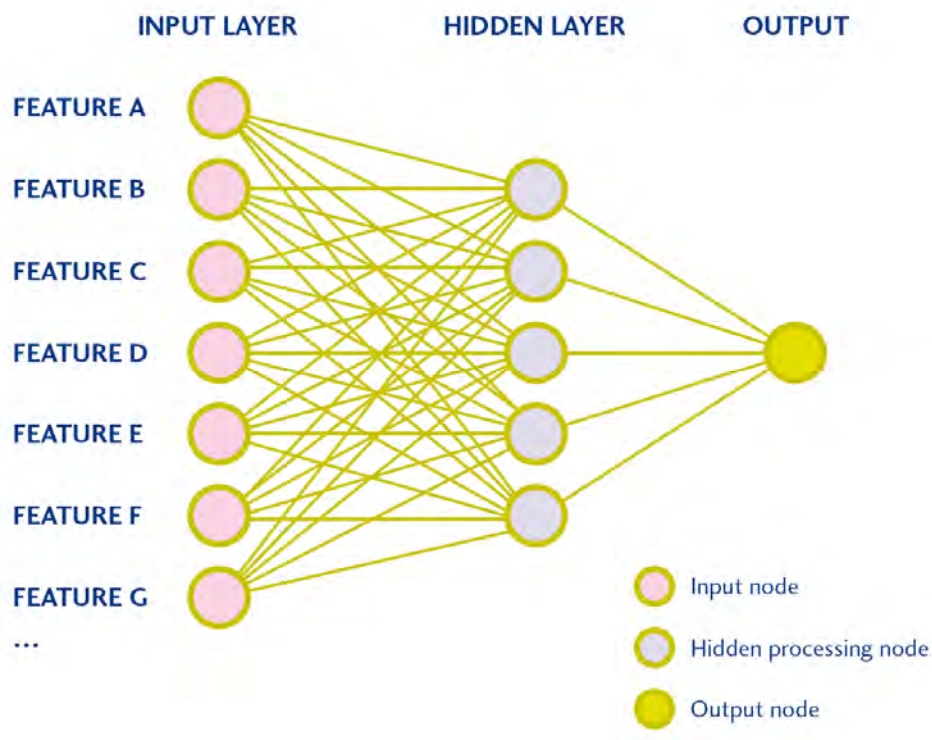

Figure 40: A basic structure of interconnected group of nodes.
 Source: <http:// <http://sany-ip.eu/book/export/html/3271>>28/10/10

Neural networks derive their strengths from the following (Obot and Uzoka, 2009):

- (a) Compact knowledge representation in the form of weight and threshold value matrices, thus giving it fast and simple operation.
- (b) They learn inductively from training data and have the ability to process non-linear data such as found in medical diagnostic problems.
- (c) They require no prior knowledge of data relationships.

However, neural networks suffer from the following setbacks (ibid):

- (a) They are incapable of handling linguistic, vague and imprecise information.
- (b) They need a lengthy training period and have limited explanation facility.
- (c) It is difficult to incrementally add new knowledge in neural networks.
- (d) As the networks grow it become difficult to retrieve cases.

An ANN is configured for a specific application, such as pattern recognition (Rajan et al., 2009) or data classification (Li et al., 2009), through a learning process. As the conceptual design phase in engineering or product design is one of the important design phases, a number of attempts to automate this phase using intelligent computer systems have been made (Potter et al., 2001). However, the knowledge of how to generate designs has been difficult to acquire directly from human experts, and as a result, is often unsatisfactory in these systems (ibid). Potter et.al, (2001), have investigated the applicability of inductive machine learning techniques to the acquisition of conceptual design knowledge of fluid power circuits to overcome the issues of difficulties of acquiring the design knowledge directly from human experts. A number of issues have been highlighted and discussed that must be considered in order to achieve efficient design solutions regardless of the working domain.

2.8.5 Genetic Algorithm

Genetic algorithms (GA) are members of a collection of methodologies known as evolutionary computation. These techniques are based on selection and evolution process that imitates the nature. GA that we know at present were introduced by John Holland in the 1960s, and later on further developed by him with his colleagues in the 1960s and 1970s (Mitchell and Forrest, 1994). The goals of their research

were two; firstly to summarise and explain the adaptive processes of natural systems, and secondly to develop artificial systems software that represents mechanisms of natural systems (Goldberg, 1989). GA have since been continuously improved and developed by researchers which has remained an active area of research until now. GA is robust and can solve problems quickly. Robust means that GA can deal with problems with many parameters and complex problems such as changing or dynamic environments (Goldberg, 1989). This is because of their adaptive or suggestive nature rather than trying to find a single desired solution which may not be feasible or very difficult to achieve (ibid).

GA is extensively applied in fields such as biology, medicine, computation, engineering, arts, etc. There are so many applications to be listed but only a few will be mentioned here. An example of application of GA in engineering are to generate optimal planning to convert job shops to cellular manufacturing systems with minimisation of the total material handling cost (Rezaeian et al., 2011). In medicine, GA are applied to solve medical problems, including diagnosis, prognosis, imaging, signal processing, planning and scheduling (Peña-Reyes and Sipper, 2000). In the field of product design, Graham developed software that can produce designs through evolution of form designs (Graham et al., 2001). The software prototype was named Evolutionary Form Design (EFD) that can generate a set of shapes which will undergo evolution processes to produce the next set of new form of product designs as shown in Figure 41. GA have also been applied as support tools to computer based systems applied to detailed design (Renner and Ekárt, 2003).

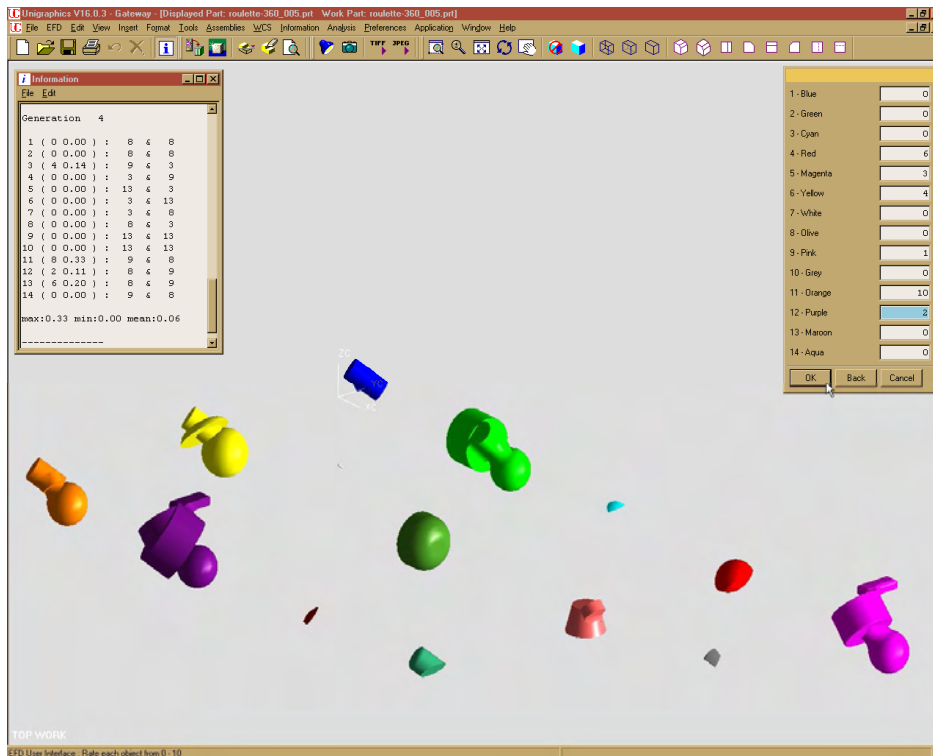

Figure 41: Screen shot of shapes produced with EFD.
(Graham et al., 2001)

2.9 Summary

This chapter has explored and discussed various thoughts, process and research particularly related to the design. Conclusively, design is seen as a possible but subjective matter. This leads to different sets of interpretations being used by different researchers. This chapter also has given some background on the understanding of the design process, design methodology, design support system and its development in today's world of design research. The literature available on the aspect of design for AM products is severely limited. So far, within the AM field, little attention has been given to supporting the product design phase, since the research emphasis is normally on the development of the technology itself (processes, materials, building strategies, system selection, manufacturing parameter optimisation etc). The next chapter will describe AM in terms of theoretical foundation, current research status and significant related work.

Chapter Three: Additive Manufacturing

3.0 Chapter Overview

The previous chapter presented and discussed various thoughts, methods, process and decision support system particularly related to design and AM. This chapter will describe AM in terms of theoretical foundation, current research status and significant related work. It will also provide definitions, assumptions and a basis for classifying and positioning this research.

3.1 Introduction

The scope of the literature review for this chapter began with defining the important concepts and terms of AM and to gain an understanding of the principles of AM and the systems used to support it. The review also seeks to identify research gaps in order to position the original knowledge contribution of this research.

3.2 Definition of Additive Manufacturing

AM process has come through an evolution of Rapid Prototyping (RP) technologies over the past 20 years (Wohlers, 2008). AM is a generic name for a range of new technologies capable of producing end use products directly from CAD data in a very short timescale. According to Wohlers (2008) AM can be defined as *“the use of a computer aided design (CAD) based automated additive manufacturing process to construct parts that are used directly as finished products or components”*.

The definition of AM can vary greatly depending on which stage of the production stage people are utilising it. For some people, AM can mean simply making end use parts directly by layer-based manufacturing methods while for others it involves the use of AM processes at any stage in the production chain(ibid). There are various terminologies used at present that could be seen as alternatives to the internationally recognised term of AM (ASTM, 2010) such as 3D printing, additive fabrication, layered manufacturing, additive layered manufacturing, layered free-forming, part

growing, freeform fabrication, layer-based manufacturing and rapid manufacturing. These variations of terminology have resulted due to various perspectives that appears from the industry and academic that utilise the systems. In the US, solid freeform fabrication is the preferred term for AM. In broad terms AM can be summarised as a technology for producing end use parts by adding, or building up material to form an object from 3D CAD data. The term additive manufacturing will be used throughout this thesis.

However, with all the conflict in the definition that exists, it cannot be denied that at present RP machines are being used to make AM products. In future it is expected that the production processes could differ and a multi-axis production process could be used instead of the present preference of layer-based manufacturing (Hopkinson et al., 2006).

In general, AM eliminates the need for tooling and shortens the overall time to manufacture. AM also differs from conventional manufacturing technology in that the concept of manufacture is not subtractive or formative (such as machining away material or moulding and casting to form product), but rather the “workpiece” is build by adding material in layers until a complete finish product is produced. The term “rapid manufacturing” is often used in a holistic sense to express the relative speed with which products can be made when less direct production methods, such as moulding or casting, are eliminated. As a result, “rapid manufactured” parts can be available in a matter of hours and minutes, instead of the months and weeks associated with more conventional tool-based methods of manufacture. This shortening of production lead times is also described as time compression engineering (TCE) (Pham, 2003).

3.3 A Brief History of AM

AM started over twenty years ago and was commonly called rapid prototyping (RP). RP was a generic phrase coined to cover manufacturing technologies which enabled the generation of models without tooling or manual work. At the time machines were used to make things that represented the general physical shape of some final part or other items. RP started out by making prototypes made from polymers for visualisation, communication and inspection tools (e.g. assembly). The fabrication of conceptual and functional prototypes made from polymers is now well established in the market. Components made by AM techniques are gradually being used less for visualization tools and for assembly testing, as these activities can be carried out using virtual prototyping (Pham, 2003).

The next natural step for these techniques was to produce functional tools directly from metals or ceramics. This extension of RP technologies was called Rapid Tooling (RT). RT can be defined as a process for fabrication of moulds and dies by AM directly from RP machines and has been the subject of much research (Levy et al., 2003). The current future trend is shifting towards using AM for the fabrication of end use parts, thus eliminating the need for most prototype tooling and production tooling. The term “rapid manufacturing” arose in a natural way, and at least partially as a way to differentiate it from rapid tooling (ibid).

Early versions of RP systems were unable to produce end use products due to limitations such as poor material properties, a lack of CAD solid modelling systems needed to support RP and unreliable RP system capabilities (Hopkinson et al., 2006). Once these deficiencies had been overcome, it became possible to make functional parts that could be used in final use applications. “Mass customisation” consequently arose as a new possibility. While it is still not typically to speak of manufacturing with a lot size of one, it is not at all difficult to find applications where only a few items are needed.

Additive processes are turning out to have good prospects for many of these applications, especially ones that involve complex shapes (Wohlers, 2008). As a result of various research and development projects, AM systems have recently

shown the potential of being able to produce robust components that can be classed as end-use parts (Hopkinson et al., 2006). The field of AM has grown in recent years and offers such significant potential that it must be considered as a discipline in its own right that is independent from its predecessors of RP and RT (ibid). This new discipline, which eliminates tooling, has profound implications on many aspects of the design, manufacture and sale of new products (Wohlers, 2008). Figure 42 shows the general progression of these technologies.

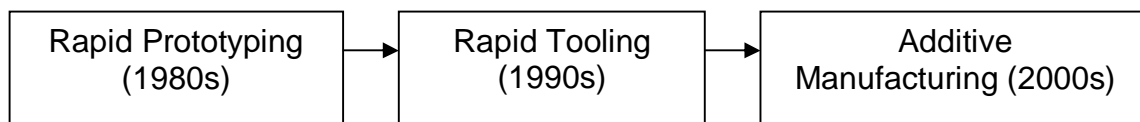

Figure 42: Expansion of additive technology

Currently, criticism of the concept of AM usually comes from comparing material properties, surface finish, and speed of manufacturing with conventional processes. This is often due to AM being seen as an extension of RP and so parts are not seen to be suitable or intended for end use (Hopkinson et al., 2006). Thus, overcoming this view will certainly take time. More evidence of product success and the ability to overcome the issues mentioned above are needed to enable AM to be commonly accepted as a new method of manufacturing. However, AM is unlikely to completely replace other manufacturing techniques, especially for large production runs where mass-production is much more economical. For short production runs, nevertheless, AM can be much cheaper, since it does not require tooling.

3.4 AM Generic Process

AM requires a number of generic steps to produce a part or a product. Although many different AM systems exist, most employ seven important steps (Figure 43) (Munguia et al., 2008), (Gibson et al., 2010). The generic steps are:

- i. Create a 3D CAD model of the part or product
- ii. Convert the 3D CAD file to STL (Standard Triangulated Language) format & slice the STL file into thin cross-sectional layers (or use a direct slicing algorithm)
- iii. Part orientation and placement for building
- iv. Support structure generation (not needed for some systems)
- v. Part construction
- vi. Post processing (not needed for some systems)
- vii. Finishing such as sanding or painting if needed

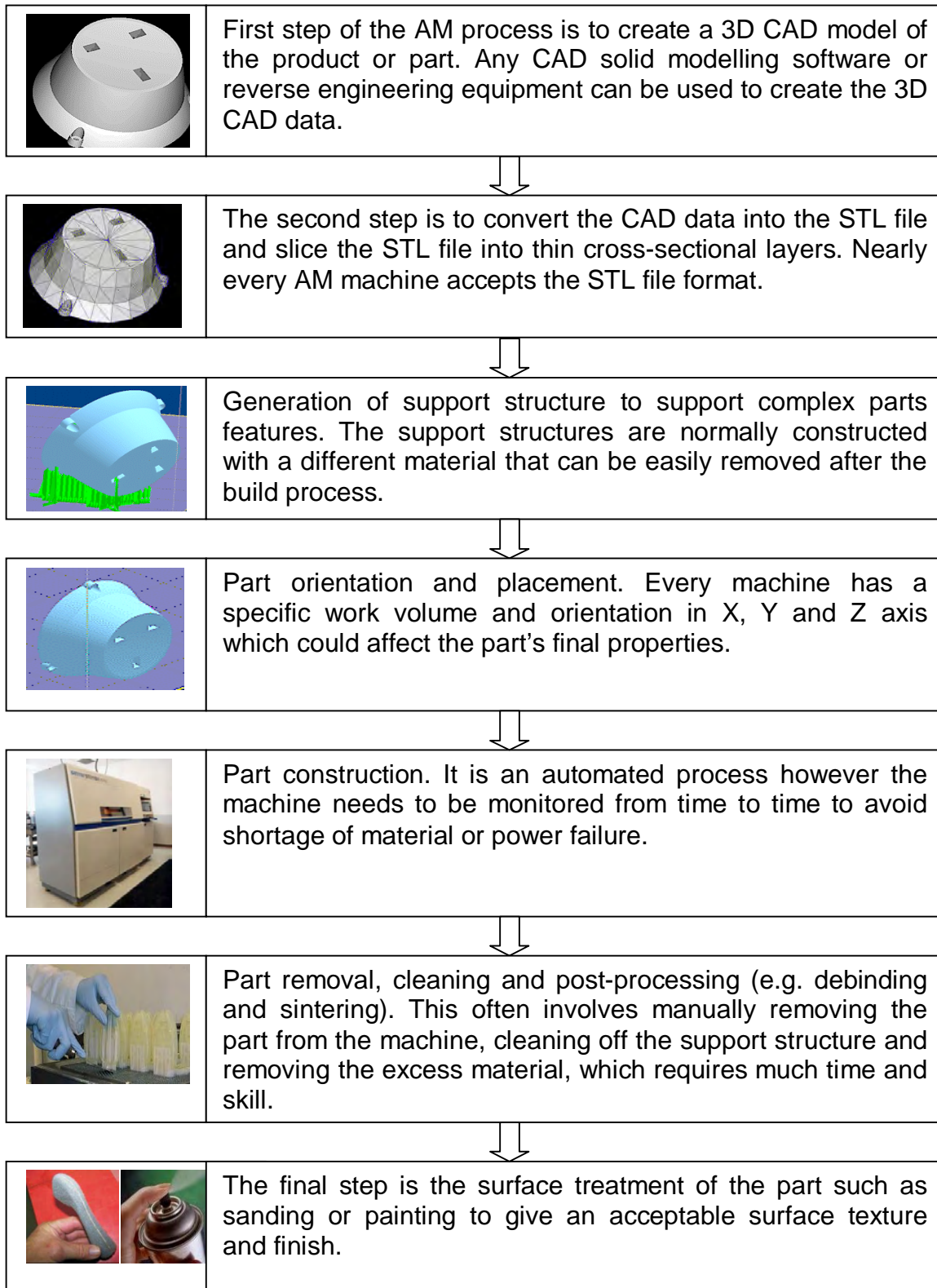

Figure 43: Seven AM Generic Steps
(Gibson et al., 2010)

3.5 AM Systems

There are over 20 different recognised RP technologies (Wohlers 2008). Not all of these can be considered as suitable for AM as some have material properties that are not suitable for anything beyond visualisation, such as the 3D printing system. Another example is the models created in wax by the Thermojet process would have limited mechanical properties but may be entirely adequate for their intended use of visualisation or investment casting patterns (Hopkinson et al. 2006). Some common AM processes that are described in the next section include Stereolithography (SLA), Laser Sintering (LS) and Fused Deposition Modeling (FDM).

3.5.1 Stereolithography (SLA)

Stereolithography is one of the first polymer prototype technologies to be developed. SLA systems use 3D CAD data to convert liquid resin and composite materials into solid cross-sections, layer by layer, to build highly accurate three-dimensional parts (Wohlers 2008). SLA technology was developed initially by 3D Systems in 1986. The driver for using SLA technology as an AM process lies with more recent material developments. SLA systems can process many different types of polymer materials with different properties and some of these are considered suitable for AM. Due to its accuracy, mechanical properties and surface finish, it has become one of the most popular AM methods (Chockalingam et al. 2008).

SLA utilises a photo-curable liquid resin in combination with an ultraviolet laser. A vat of the resin sits underneath the laser, and the laser “draws” on the top layer of the liquid (Weheba and Sanchez-Marsa 2006). When the ultraviolet laser beam hits the liquid it hardens a small amount of resin under the beam point. By drawing the outline, and then filling the interior, a solid layer of material is created. This layer is then lowered a small amount into the vat, a new layer of liquid is placed on top, and the process repeats itself. By creating one flat layer at a time, a very precise geometry can be created resulting in a complete part. Figure 44 shows the schematic diagram of the SLA process.

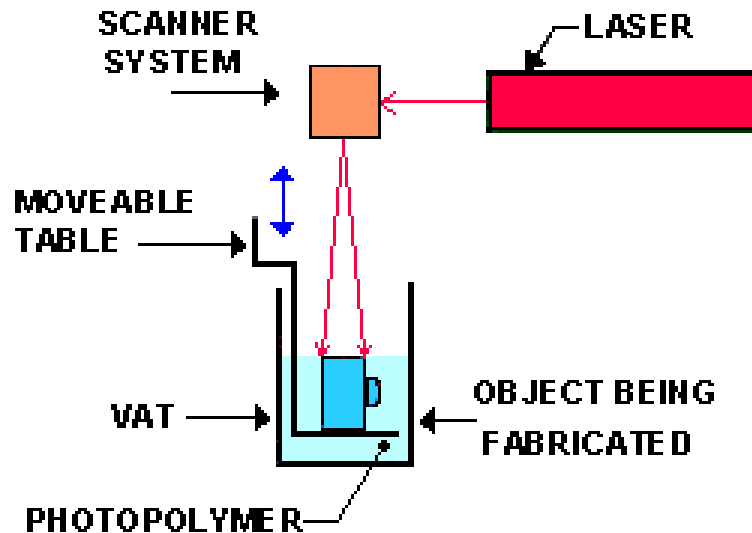

Figure 44: Schematic Diagram of SLA Process

Source: <http://home.att.net/~castleisland/sla_int.htm> 10/03/09

The finish quality of SLA part can suffer if the condition inside the build tank is not optimum such as free of dirt or dust. Phenomena like fogging can occur on the scanning system mirrors, caused by the curing process, and this can then affect part accuracy (Weheba and Sanchez-Marsa 2006). Once complete, the SLA part requires post processing. At a minimum, SLA parts are post cured to complete the polymerisation process and to improve the final mechanical properties of the part (ibid).

Most AM parts properties differ from those produced with traditional engineering materials. Research shows that SLA resins, although producing mainly isotropic parts, have a phenomenon not shared by laser sintered parts, i.e. they show a degradation of their ultimate tensile strength over time (Saleh et al. 2004). There are also reports that SLA mechanical properties improve in the short term as the material continues to cure but will then begin to degrade over time (Hopkinson and Dickens 2000). However, the degradation of the mechanical property can be improved with the development of better resin material property. Overhanging or unconnected areas have to be supported for SLA process. Supports are generated by the build software and built along with the part. When a part has been built, it is removed from the vat, excess resin is washed off using a solvent and the supports removed.

SLA system can rapidly manufacture parts of different geometries at the same time and are designed to produce prototypes, patterns or end-use parts of versatile sizes and applications. Figure 45 shows an example of a rather complex fruit tray produced with the SLA process. Table 8 provides a summary of the SLA process.



Figure 45: Example of a fruit tray produce with SLA process

Source: <<http://www.mgxbymaterialise.com/principal-collection/family/list/>> 10/03/09

Process	A low-power ultraviolet laser beam is moved over the surface of a vat of photocurable liquid polymer, producing a single layer of solidified resin - the first slice of the object under construction. The initial layer is then lowered incrementally by the height of the next slice, whereupon the layer is recoated with resin and another is traced on top of it. This procedure is repeated until the entire part is fabricated.
Materials	Photopolymers based on acrylic or vinyl or epoxy resins
Accuracy	± 0.05 - 0.1 mm
Layer-thickness	0.05 - 0.5 mm
Max. dimensions	(1500x 762x 600mm) iPro 9000xl from 3D systems
Advantages	High resolution; e.g. for integral parts with fine and complex structures with many different geometry elements, ribs, guiding, suspensions. Any geometrical shape can be made with virtually

	no limitation. Oldest commercial available process, large selection of machines.
Disadvantages	Labour requirements for post processing especially for cleaning. Supports structures are required for overhangs and cavities. Restricted areas of application due to given material properties.
Applications	Master models for tools that can be used for pre series production tests. Medical models, form-fit functions for assembly tests and manufacture of end-use parts.

Table 8: Summary of the Stereolithography Process.
(Chua et al., 2010)

3.5.2 Laser Sintering (LS)

Laser Sintering (LS) is an AM technique that uses a high power laser (for example, a CO₂ laser) to fuse small particles of plastic, metal, or ceramic powders into a body representing a desired 3D object (Kruth et al. 2003). Originally “Selective Laser Sintering” was developed and patented at the University of Texas at Austin in the mid-1980s and was licensed to DTM Corporation of Austin, Texas. In 2001, 3D Systems Inc. acquired DTM Corporation and now manufactures and sells LS systems and powder materials worldwide under the trademark “SLS” (Dimov et al. 2001). Another company that manufacture and sells LS systems is EOS which has their headquarters in Germany. EOS produces metal LS systems for the production of tooling inserts, prototype parts and end use parts directly in metal. EOS also produces plastic LS systems for the direct manufacture of spare parts, functional prototypes and pattern for investment or vacuum casting. Furthermore, EOS also produces sand LS system for direct production of sand cores and moulds for metal castings.

LS process is one of the leading AM techniques because of its many advantages compared with other AM processes such as SLA and FDM (Kruth et al. 2003). Fast building speeds, a wide range of materials, reduced need for support structures and simple post treatment have made LS popular for extensive application areas

(Hongjun et al. 2003), (Dimov et al. 2001), (King and Tansey 2003). As a result of its many advantages, the LS process has been highly researched since its invention at the end of the 1980s and has been rapidly developed (Song et al. 2007).

Compared to other AM methods, LS can produce parts from a relatively wide range of commercially available powder materials, including polymers (nylon, also glass-filled or with other fillers, and polystyrene), metals (steel, titanium, alloy mixtures and composites) and foundry sand (Kruth et al. 2003). The physical process can be full melting, partial melting, or liquid-phase sintering. Depending on the material, up to 100% density can be achieved with material properties comparable to those from conventional manufacturing methods (Kruth et al. 2007). In many cases, large numbers of parts can be packed within the powder bed allowing very high productivity (Wohlers 2008).

LS technology is in wide use around the world due to its ability to easily make very complex geometries directly from digital CAD data (Wohlers 2008). While it began as a way to build prototype parts early in the design cycle, it is increasingly being used in limited run manufacturing to produce end-use parts (Yadroitsev et al. 2007), (Rochus et al. 2007), (Levy et al. 2003).

In the LS process, the laser selectively fuses powdered material by scanning cross-sections generated from a 3-D digital description of the part (e.g. from a CAD file or scan data) on the surface of a powder bed. After each cross-section is scanned, the powder bed is lowered by one layer thickness (typically 0.1-0.3mm), a new layer of material is applied on top, and the process is repeated until the part is completed (King and Tansey 2003). The sintered material forms the part while the unsintered powder remains to support the structure and may be cleaned away and recycled once the build is complete. Figure 46 shows a schematic diagram of the LS process. Examples of LS products are shown in Figure 47. Table 9 provides a summary of LS process.

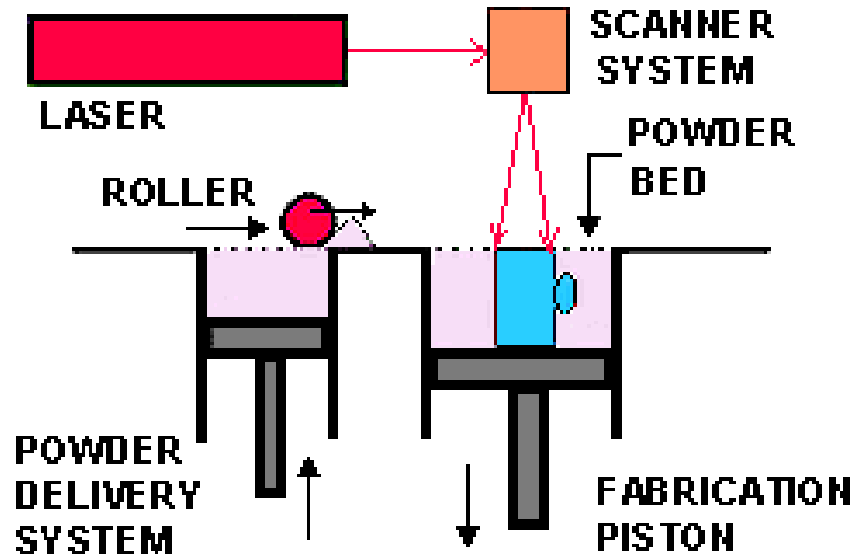

Figure 46: Schematic Overview of LS Process
 Source: < http://home.att.net/~castleisland/sls_int.htm>10/03/09



Figure 47: Examples of a laser sintered chair
 Source: < oobject.com> 13/03/09

Process	Layer wise selective fusing of powder materials through a laser beam
Materials	Thermoplastics like polystyrene, polycarbonate, and polyamide polycarbonate, polyvinylchloride (PVC), nylon, modelling wax, metals, metal powders, sand, ceramics and investment casting wax.
Accuracy	± 0.1 - 0.2 mm
Layer-thickness	0.1 - 0.3 mm
Max. dimension	700x380x580mm (EOS EOSINT P730)
Advantages	Parts do not require any post-curing except when ceramics are used. Fast build time. There is no need to create a structure to support overhanging geometry, except when metals are used.
Disadvantages	Toxic gases emitted from the fusing process have to be handled carefully (especially with PVC). The roughness of the surface can lead to reduced mechanical properties.
Applications	Visual representation and functional tough parts. Patterns for vacuum, die and sand casting

Table 9: Summary of Selective Laser Sintering Process.
(Chua et al., 2010)

3.5.3 Fused Deposition Modeling (FDM)

Fused deposition modeling, which is often referred to by its initials FDM, was developed and marketed exclusively by Stratasys Inc. FDM differs from SLA and LS systems in that it does not use a laser to create the layers of the part. The FDM machine follows the principle of a three axis NC-machine tool. A nozzle, controlled by a computer along three axes, extrudes the specific material that has been melted by heating as shown in Figure 48. The material leaves the nozzle in a semi-liquid form, which hardens immediately at the temperature of the environment. For this reason, it is fundamental for the FDM process that the temperature of the liquid modeling material is balanced just above the solidification point. A spool of modelling material filament feeds the FDM head. It can be changed to a different material in less than 1 minute (Ziemian and Crawn 2001).

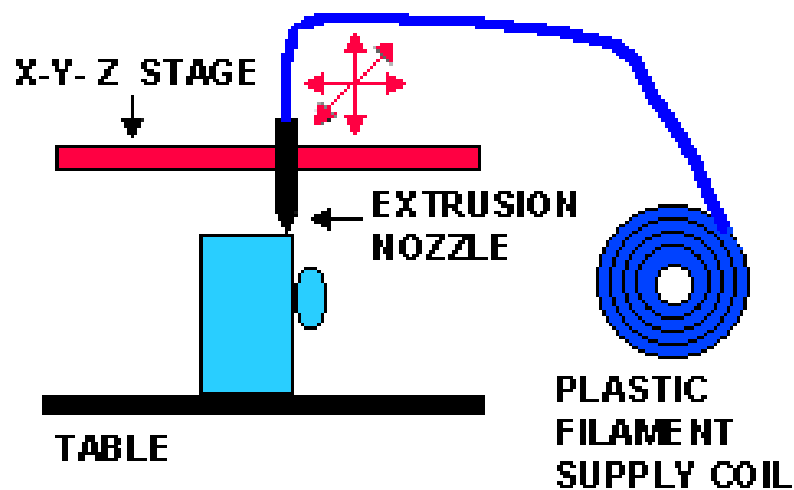

Figure 48: Schematic Overview of FDM process

Source: < http://home.att.net/~castleisland/fdm_int.htm > 13/03/09

Several materials are available with different trade-offs between strength and temperature. As well as ABS polymer, the FDM technology can also be used with polycarbonates, polyphenylsulfones and waxes (Chua and Leong 1997). Processing of typical FDM materials usually results in a lower density when compared to parts from injection moulding. An infiltration post-processing stage can be used to increase

the density. An example of a bike gauge pod made with FDM polycarbonate material is shown in Figure 49. The similarity with conventional investment casting wax also allows FDM parts to be processed without modifying the traditional investment casting process. A summary of FDM is reported in Table 10.



Figure 49 : Bike Gauge Pod made with FDM system
 Source: < <http://www.fortus.com/stratasys.aspx?id=591> > 13/03/09

Process	Melted thermoplastic is built up layer wise by an extrusion nozzle
Materials	Plastics like PA, PE, ABS, other thermoplastics
Accuracy	+/- .089 mm or +/- .0015 mm per mm (FORTUS 900mc by Stratasys, Inc.)
Layer-thickness	Up to 0.330 mm (FORTUS 900mc by Stratasys, Inc.)
Max. dimension	914 x 610 x 914 mm (FORTUS 900mc by Stratasys, Inc.)
Advantages	Quick and cheap generation of models, no toxic chemicals, system does not waste material during or after building, does not require clean-up, materials can be changed quickly, no sensitive laser applied.
Disadvantages	Fair part complexity, restricted accuracy due to the wire diameter of 1.27mm, support structures needed, post-processing for support removal.
Applications	Conceptual modelling, fit, form and functional parts for further manufacturing procedures like: investment casting, injection moulding, vacuum casting, metal injection moulding, and fine casting and some direct manufactured part.

Table 10: Summary of Fused Deposition Modelling Process
 (Chua et al., 2010)

3.6 Design Potential of AM

According to Hague (2003), AM gains its main advantage from two aspects; firstly, AM offers geometrical freedom and secondly, its ability for multiple material combination. AM is typically employed for low volume, niche applications for complex geometrical parts that are difficult to be produced with any other manufacturing method. AM is not suited to replacing many conventional manufacturing methods. Indeed conventional manufacturing methods offer a wider range of materials, better mechanical properties and better surface finish. Nonetheless, there are various fields where AM is suitable based on economic and technical feasibility.

3.6.1 Geometrical Freedom

As mentioned above, one of the major benefits of AM processes is that it is possible to make virtually any complexity of geometry at no extra cost. In conventional methods of manufacturing the cost of a component is directly proportional to the complexity of the design. In contrast, the cost of an AM process is determined by the time to build a certain volume of part, which in turn is determined by the build orientation of the component (Ruffo et al. 2007). Areas of particular interest that are enabled by the geometrical freedoms offered by AM include (Hague et al. 2003):

- i. Design Complexity
- ii. Parts Consolidation
- iii. Parts Customisation
- iv. Multiple Assemblies

3.6.1.1 Design Complexity

The foremost benefit of AM is its ability to manufacture geometry of virtually any complexity entirely without the need for any tooling. Based on a generative computer script, an example of a chair designed with a theme of organic growth is shown in Figure 50. The chair is produced with laser sintered nylon.



Figure 50: Chair developed with laser sintering
Source: < <http://www.futurefactories.com/> >07/07/2011

The need for tooling in conventional manufacturing represents one of the most restrictive factors for today's product design and development (Hague et al. 2003). According to Hague et al. (2003), designers have been accustomed with developing design with manufacturing consideration in mind. For example, with injection moulding they need to consider the requirement for the runners, gating, sprues, etc. creating achievement of restricted geometry. In contrast, with AM, product with any design complexity can be produced without additional cost. This freedom of design is one of the most important features of AM which could result in reducing the lead time and ultimately the overall manufacturing cost (ibid).

There are several other cost advantages of AM that can be gained with the elimination of tooling and also could be considered as the benefits of AM such as (Bak, 2003):

- **Waste.** Unlike subtractive machining processes that generate waste in the form of chips and unused stock, most additive processes use little more material than the object requires. In addition, disposal or recycling costs are avoided or reduced.
- **Inventory.** Generation of objects of various sizes from a common pool of powdered or liquid material as opposed to a diverse inventory of pre-sized stock cuts cost.
- **Labour.** Near net shape eliminates the skills and time needed for multi-part design, machining, and assembly.
- **Quality control.** As production is driven by digital information, there is less opportunity for human error.
- **Set-up.** If a single material is used, set-up costs are principally focused on CAD file preparation and verification. These, however, are done off-line, and do not impact machine production utilization.

3.6.1.2 Part Consolidation

The ability to produce parts of increased complexity provides greater scope for the merging of several assembly components, allowing the production of highly complex multi-functional single parts. Parts consolidation is an extension of the freedom of design mentioned above. Part consolidation offers significant cost savings where the numbers of components that would traditionally require assembly to make manufacture possible can be reduced. Figure 51 shows an example of part consolidation where a complex ducting channel assembly has been consolidated into just one part when using an LS system. This technique has been used by a US aircraft manufacturer for the production of ducting for use in fighter aircraft. Figure 52 shows an assembly of over 25 parts that has been consolidated into just one piece and then manufactured by SLA. There is also the additional benefit of improved

performance since joints were eliminated and hence could not leak. Moreover, the capability of AM to consolidate parts will also have a positive impact on time, cost and quality of the product manufactured.

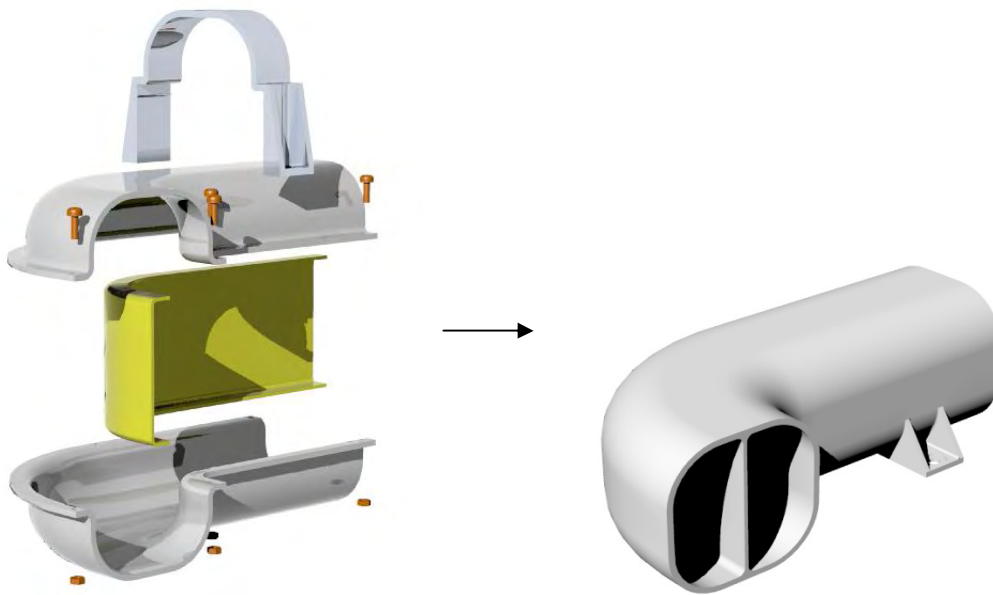

Figure 51: Example of parts consolidation in aircraft ducting.
(Hopkinson et al. 2006)

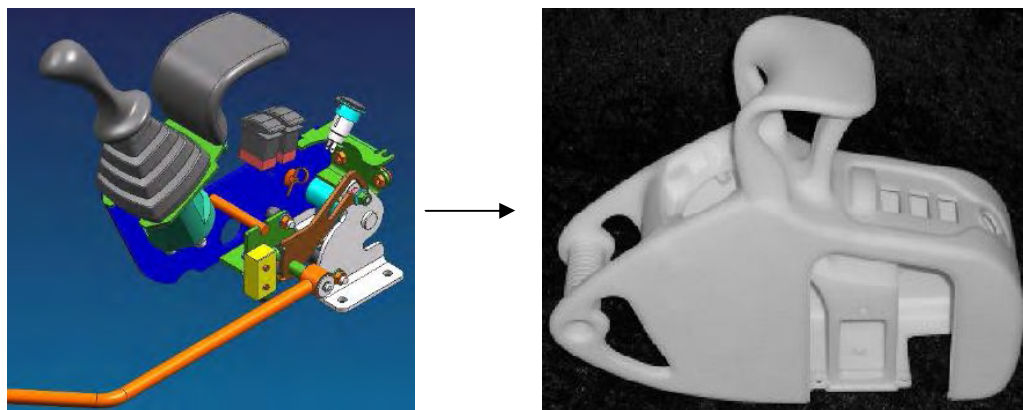

Figure 52: Consolidation of the control pod.
(Hopkinson et al. 2006)

3.6.1.3 Parts Customisation

AM is free from tool-based cost restrictions, making the production of low volumes an economic feasibility. It is possible to produce customised components that are built to fit individual. The ability to rapidly produce parts to order removes the need to physically ship components in bulk from supplier to user. It also removes the need to predict what spare parts require storage, as they may be made on demand from a stock of raw material. Besides cost reduction, AM is also capable of responding to changes in a sales forecast or manufacturing schedule without the need for unnecessary additional cost (Ruffo et al. 2007).

The production of customised products is not novel. In recent years there has been a trend toward customisation of products. AM application to customisation has shown great advances in body fit parts such as for hearing aids, dental implants and orthopedic parts (Truscott et al. 2007). AM customised medical products are made to meet the needs of each customer. It has also been realized that rapid customisation is able to increase the level of ergonomics and comfort (Traini et al. 2008). Custom-made products and a spirit of innovation are two elements found in many successful AM implementations. However, there are various other industrial sectors which make use of AM that will be described in the following section.

True customisation is not feasible for the mass market at present. The concept of mass customisation is currently employed to give some degree of customisation (Hopkinson et al. 2006). However, mass customisation is achieved by modularisation – the production of modules that can be bolted together in varying configurations, which can give the economies of mass production but allow some choice in the product (ibid). By using postponement techniques, the decision of how the final product is configured can be delayed to allow for greater degrees of customisation.

The ability to produce one-off items supports a move from mass customisation towards parts that are customised to meet the specific wants or needs of individual users. The removal of production tooling and associated cost restraints makes it economically feasible to produce single “one off” items and products that are unique to individual user specifications. However, conventional manufacturing is still used

currently for customisation and this needs costly tooling (Hopkinson et al. 2006). AM can therefore provide a cost effective and greater level of customisation. As an example of AM user fit customisation, the golf club grip seen in Figure 53 was custom made for an individual golfer at the Auckland University of Technology, New Zealand. This was made possible by fully exploiting AM techniques to produce freeform components. Throughout this project the designer had to ensure that maximum ergonomic impact was made while maintaining the golf club grip functionality.



Figure 53 : Golf club grip.

Source: Olaf Diegel, Auckland University of Technology, New Zealand

3.6.1.4 Multiple Assemblies

Another areas of particular interest that are enabled by the geometrical freedoms offered by AM include creating individual links that could be used to produce garments. An obvious example of this particular benefit is in the manufacture of AM textile structures (Figure 54).



Figure 54: AM weaved bag.

Source : < <http://www.freedomofcreation.com>> 07/07/11

3.6.2 Multiple Material Combinations.

Besides the main advantage of AM that offers geometrical freedom, another advantage is the possibility to build a component with two or more materials in a single part. Objet's one of the leading multi-material 3D printing systems company produced the Connex machines. The Connex family offers the ability to print parts and assemblies made of multiple model materials, with different mechanical or physical properties, all in a single build. This technique allows designers to produce parts that have added functionality and enhanced design such as the tooth brush shown in Figure 55 that has a stiff handle, an over moulded grip and a different material at the neck to give a flexible head. Another example of shower gel dispenser is shown in Figure 56. Other benefit from multiple material manufacturing would be the reduction of production development costs and cycle time. However, the CAD functionality needed to meet the requirements for multiple materials still remain a challenge.



Figure 55: Tooth brush.

Source: < <http://www.paramountind.com/consumer-goods-prototype.html>>
14/03/09

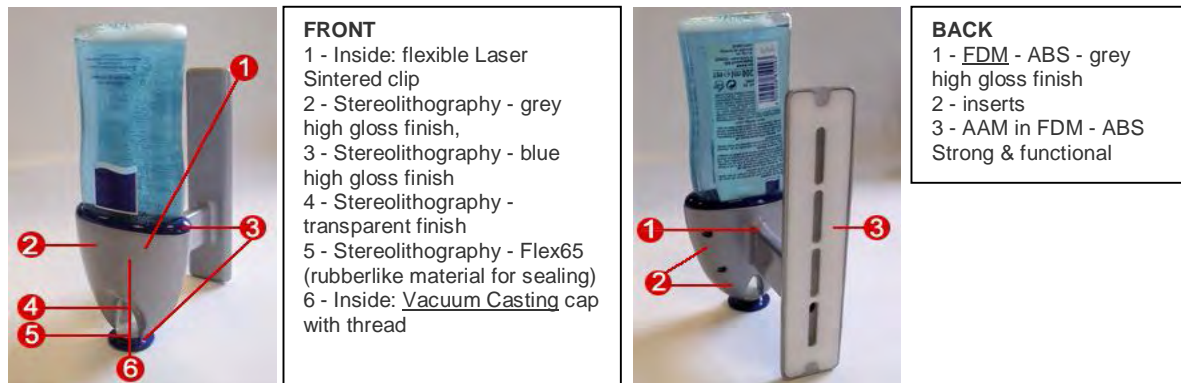

Figure 56: Shower Gel Dispenser

Source: < <http://www.materialise.com/materialise/view/en/370602-FDM+shower+gel+dispenser.html>> 13/03/09

3.7 Applications of AM.

Each year, Wohlers Associates surveys many companies worldwide representing hundreds of system manufacturers, service providers and customers that benefit from parts produced with AM. In 2011, 32 system manufacturers and 70 service providers worldwide represent an estimated 6,000 users and customers provided information on a survey. Based on their knowledge of those users and customers responded to a survey, respondents said that in 2005, 8.2% of their activity was AM of end-use parts. It grew to 14.9% in 2011 (Figure 57) which means that AM is now on progressing (Wohlers, 2011).

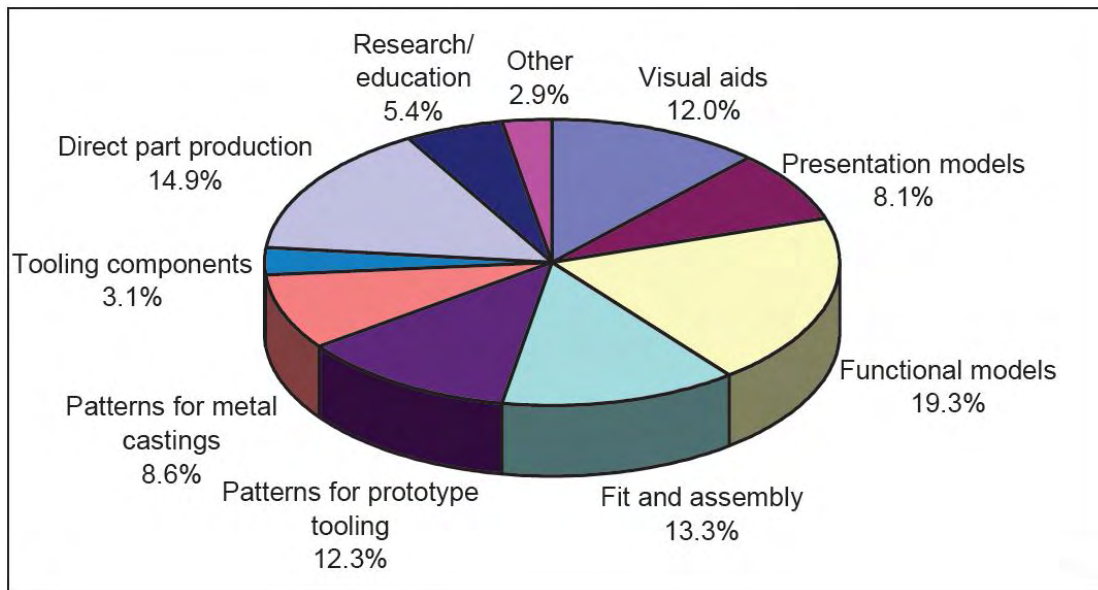

Figure 58: Application of AM worldwide. (Wohlers, 2011)

According to Wohlers (2008), there are three segments that make up the largest use of AM technology. The biggest is the consumer and electronic products sector, followed by the transportation industry and finally the medical sector. Historically, one of the reasons for this was that these businesses were producing the types of products that needed to a reduction in product development costs. Due to short product life cycles, high added value and complex geometries, these products are ideal for production using AM technologies. However, other sectors that have emerged as beneficiaries from AM technologies are the creative industries, home furniture and interior products, jewellery, art and sculpture (Wohlers 2008). Some of the main application sectors of AM are described below:

3.7.1 Consumer Items

One of the main benefits of AM (which not only applies to end use consumer products but also to artistic objects) is that it supports the realisation of aesthetic features which may not have been possible to make any other way. As a result, AM is being used by a number of industrial designers to build a wide variety of consumer products. One such company is Freedom of Creation (FOC), who produces a variety of design artefacts which range from fashion accessories to interior design goods.

Examples of various consumer products designed by FOC include lighting, stools and a punch bag as shown in Figure 58.



Figure 59: Various AM Consumer Products
Source: < <http://www.freedomofcreation.com/> > 12/03/09

3.7.2 Transportation

The aerospace industry has always been a major consumer of AM technology. Aircraft parts such as housings for electronics, ventilating components, air-ducts, jet engine components, etc., are being fabricated by AM (Santos et al. 2006), (Yadroitsev et al. 2007). The aerospace industry suffers losses if an aircraft is grounded due to lost business and hanger fees. In order to avoid this loss, spare parts have to be kept ready “on the shelf”. Parts for aircraft are made in small quantities, are often complex and must meet stringent legal requirements (Santos et al. 2006).

A typical aircraft consists of around four millions components thus the inventory cost of these components is high (Hall, 2011). By adopting AM, the industry is able to produce parts on demand thus reducing the inventory cost. Boeing’s Rocketdyne propulsion and power section has used LS to manufacture low volume parts such as for the space lab and space shuttle. NASA’s Jet Propulsion lab has also used LS to make parts launched into the upper atmosphere (Hopkinson and Dickens 2001).

Figure 59 shows examples of aerospace parts built using a LS system. The figure shows that it is possible to create a part that has both external and internal complexity. This shows that AM can create highly functional parts and also has the

potential to consolidate several parts into one that could save manufacturing cost, reduce assembly time and increase part reliability. The principal advantage of AM for this application is that there is no tooling required and only a modest amount of machining and finishing is required. Furthermore, 98% of the excess powder material will be recycled and so the LS process can be argued to be economical and environmentally friendly.



Figure 60 : Metal laser sintered aerospace parts.
Source : < <http://www.3trpd.co.uk> > 12/03/09

AM processes are increasingly used in the production of customized parts for concept cars. AM allows one-offs customized parts to be manufactured. An example of this is the Sintesi, a new concept car that explores ideas for the car of the future presented at the 78th International Motor Show in March 2008 at Geneva. The complexity of the dashboard combined with the translucent aspect, required the use of AM. The manufacturer used AM, specifically SLA, to produce customised car seats and the instrument panel as shown in Figure 60.



Figure 61: Sintesi – AM application in concept car
Source : < <http://www.materialise.com> > 13/03/09

At the International Additive Manufacturing Conference, held at Loughborough University, UK, in July 2007, CRP Technology presented a case study ‘Turning point

in the creation of racing engines: structural parts made by laser sintering'. The paper explained how they implemented AM in a four-stroke MotoGP engine development. Besides the numerous non-structural parts manufactured by LS that can be found in the engine, the major innovation was the camshaft cover. This is a structural part that supports the camshaft bearings that rotate at 19,000rpm and that is mounted directly on the cylinder head of the four-stroke 800cc engine, whose average working temperature is about 130-140°C (Figure 61). LS were used to reduce the weight of the camshaft cover. In addition, AM enabled modifications to be made faster.



Figure 62: Structural parts of a motor produced with laser sintering (in white)
Source: < <http://www.engineerlive.com/> 12/03/09

3.7.3 Medical & Healthcare

The medical sector is one area in which much AM has been performed in recent years. AM is employed to build high value tailored parts in several medical fields (Truscott et al. 2007), (Singare et al. 2009), (Williams et al. 2005) & (Hieu et al. 2005). The application of AM in the medical industry is also known as Medical Rapid Prototyping (MRP) (Kouhi et al. 2008). MRP involves the manufacture of dimensionally accurate 3D physical models of human anatomy derived from medical image data. MRP plays an important role in design and manufacturing of implants and surgical tools. The clinical applications of MRP models could include reconstructive operations such as oral and maxillofacial surgery (Hieu et al. 2005), (Gopakumar 2004) & (Singare et al. 2006), dental implant (Bibb and Eggbeer, 2006)

& (Traini et al. 2008) and orthopaedics (Ng et al. 2002), (Kouhi et al. 2008). It was realised that rapid customisation of various surgical implants was able to increase the level of ergonomics and comfort and thus improve the quality of life (Traini et al. 2008). Figure 62 and Figure 63 illustrates a custom skull implant and a custom dental bridge implant respectively. Figure 64 shows a knee implant that was built by laser sintering using a bio-compatible cobalt chrome alloy.

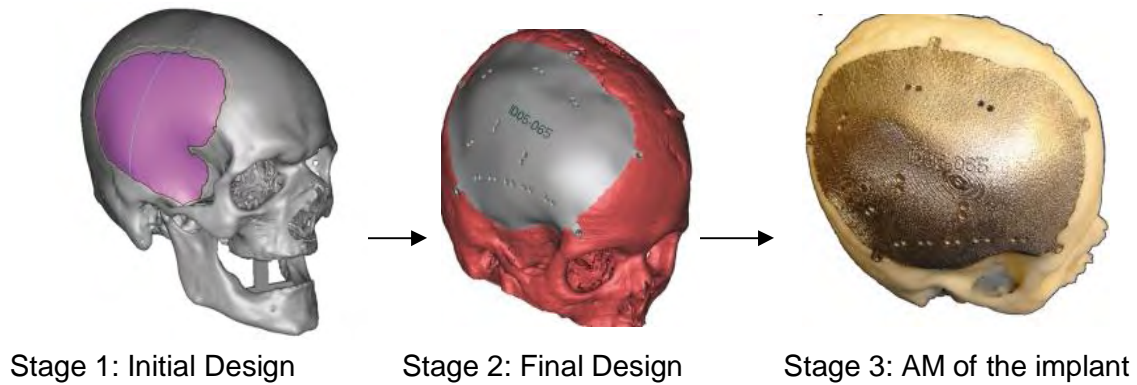

Figure 63 : Custom skull implant
Source: < <http://www.materialise.com> > 12/03/09



Figure 64: Custom dental bridge
Source: < <http://www.materialise.com> > 13/03/09



Figure 65: Custom knee implant
 Source: < <http://www.eos.info/en/home.html> > 13/03/09

Today, nearly all customised hearing aids are made using either SLA or LS. The hearing aid shell is small, its shape is complex and conventional manufacturing is expensive. No two ears canals are identical in shape and size, so the traditional method of producing a mold for each hearing aid is time-consuming, expensive and prone to error. The use of laser digitizing, dedicated software, and AM result in a custom medical product that increases comfort and performance (Hieu et al. 2005). Figure 65 shows the hearing-aid manufacturing progression from the early stages of development with generation of a point cloud resulting from scanning the ear canal impression through the 3D CAD model to the finished product.

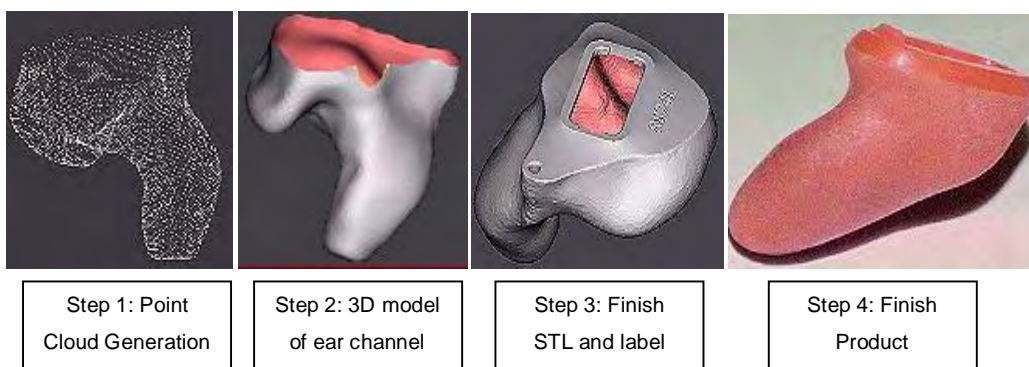

Figure 66: Additive Manufacture of Hearing Aids
 Source :< <http://home.att.net/~edgrenda/pow/pow17.htm> > 12/03/09

The European integrated Custom Fit project was launched in 2004 to produce customised medical and consumer goods manufactured with AM systems (Anton and Rafael, 2006). The project aimed to create a fully integrated system for the AM design, production and supply of individual custom products. The social aim of the project is to improve the quality of life of European citizens by providing products that meet their individual geometrical shapes and requirements.

3.7.4 Sports

AM products have penetrated an entire range of industries, including sporting goods with the intention of improving operational performance and ergonomics factor. Prior 2 Lever (P2L) is a British company has fabricated the world first LS fully customised outsole of a soccer shoes for professional athletes as shown in Figure 66.



Figure 67: Additive manufacture customised soccer shoe
Source: < <http://www.footy-boots.com/prior-2-lever-football-boots-interview-part-i/> > 12/03/09

Another example of AM application in sports is crash helmets (Figure 67) that have already been produced for competition rowers by TNO in Holland and for high speed ball games such as lacrosse or hurling.



Figure 68: Personalised sports-helmet manufactured using Laser Sintering.
Source: < <http://tno.nl/index.cfm> > 12/03/09

The Tailored Injury Prevention & Performance Improvement for Protective Sports Garments (SCUTA) project at Loughborough University that ended in September 2010 investigated the development of customised personal protective equipment (PPE) garments utilising an AM system. The project utilised AM to enable the production of garments tailored to the individual athlete taking into account variations in size and shape, which could reduce potential injuries and improve performance in the long term. Figure 68 shows examples of these protective garments.



Figure 69: SCUTA project
Source: < <http://www.lboro.ac.uk/departments/mm/research/rapid-manufacturing/projects/scuta/home.html> > 14/03/09

3.8 Challenges and Issues of AM.

Whilst the ability of AM to create practically any geometry provides designers with much freedom, it is noted that certain constraints still affect the acceptance of the technology. Rejection of the idea of using AM usually comes from comparison of material cost, material properties, its surface finish and the machining speed to existing conventional processes. Moreover, AM is seen by some as an extension of rapid prototyping and so parts are not seen as being intended for end use (Hague et al. 2003). Some other constraints noted by (Levy et al. 2003) and (Hague et al. 2003) include support material removal, production of large parts and inclusion of non AM parts.

3.9 Sources of Data for Additive Manufacturing

The increasing power of computer hardware and software has led to the development of many tools and techniques to support design activity. This next section describes some of the most important approaches to developing CAD data for AM processes.

3.9.1 Computer Aided Design (CAD)

The generation of a 3D CAD model is usually the first step in the AM process, however it is often the most time consuming part of the entire AM process (Chua and Leong, 1997). Computer Aided Design (CAD) can be defined as the use of computer hardware and software to assist users in the creation of 2D and 3D design data (Schoonmaker, 2003). CAD traditionally refers to computer tools to visualise, describe, edit and test manufactured artefacts, which are now an essential part of all manufacturing and production processes. The ability to use computers in the design process was first considered in the 1960's with the creation of the Computer Aided Drafting system, Sketchpad developed at MIT (Sutherland and Lincoln, 1963). Since then, CAD has been developed into various specialised applications ranging from large scale modelling such as for civil engineering to mid scale such as for transportation and for small scale such as the modelling of mechanical components and consumer products. CAD systems provide benefits such as lower product

development time and cost, when compared to traditional manual methods. It enables designers to design, view, edit, save and share their designs effectively. The development of CAD has resulted from the advancement in electronics, software and computing technology.

CAD systems are successful in manufacturing because they replace the specification of numerical parameters (a task that is difficult for humans to perform reliably) with the visualisation and editing of visual representations of virtual objects. Generally, a particular design is first sketched by a designer and subsequently input into a CAD system for alteration and improvement. CAD systems have powerful 3D modelling software that is typically used later on in the design process, after designers have established the basic concepts (Ullman, 1992). CAD systems often represent more than just shapes. As in manual drafting or engineering drawing, symbolic information such as materials, processes, dimensions, and tolerances can also be added, according to application-specific conventions. CAD has evolved to incorporate several other applications of computer integration with engineering, manufacturing and simulation (Lee, 1999). These include (Schoonmaker, 2003):

- **CADD** - Computer Aided Design and Drafting: the use of computers in the creation of products plans and schematics.
- **CAE** - Computer Aided Engineering: the use of computers to assist with all stages of engineering design work that also involve the conceptual and analytical design steps.
- **CAM** - Computer Aided Manufacturing: the process of utilising computers to control and monitor tools and machinery in manufacturing.
- **DCC** - Digital Content Creation: the use of computers in the creation of digital content such as animations, media and renderings.

The graphical user interface (GUI) that was incorporated into CAD software during the 1970s, greatly increased the speed and efficiency of solid modelling and marked a turning point in the design of CAD software and systems. Research into 3D curves, splines, NURBs (non Uniform Rational B-splines) surfaces, rendering, GUI's and the addition of increased computational power has transformed CAD into an essential

tool for designers and engineers. Throughout the 1990s developments in 3D modelling continued to advance from wireframe into surface and solid models (as shown in Figure 69) before moving on to constraint based modelling. As a major development in CAD technology, constraint based modelling differed from earlier CAD systems because the system keeps track of design dependencies so that when changes to any value are made, all other values that depend on it are automatically changed accordingly. In contrast, any changes made to the earlier CAD systems often meant re-modelling the entire part. CAD now offers the capability of freeform surface modelling and solid modelling operations that allow users to create almost any complex geometry and photo realistic rendered images as shown in Figure 69.



Figure 70: CAD visualisation, wireframe (left), solid & surface model (middle), photorealistic image (right)

CAD can be defined as the technology concerned with the use of computer systems to assist in the creation, modification, analysis, and optimisation of a design (Lee, 1999). More specifically, it can be thought of as comprising:

- **Hardware:** the computer and associated peripheral equipment.
- **Software:** the computer program(s) running on the hardware.
- **Data:** the data structure created and manipulated by the software.
- **Human knowledge and activities.**

CAD systems are no more than computer programs (although often large and complex), perhaps using specialised computing hardware. The software normally comprises a number of different elements or functions that process the data stored in the database in different ways. These are represented diagrammatically in Figure 70 and include all the elements stated below (McMahon and Browne, 1998):

- **Model definition:** for example, to add geometric elements to a model of the form of a component.
- **Model manipulation:** to move, copy, delete, edit or otherwise modify elements in the design model.
- **Picture generation:** to generate images of the design model on a computer screen or on some hardcopy device.
- **User interaction:** to handle commands input by the user and to present output.
- **Database management:** for the management of the files that make up the database.
- **Applications:** these elements of the software do not modify the design model, but use it to generate information for evaluation, analysis or manufacture.
- **Utilities:** a 'catch-all' term for parts of the software that do not directly affect the design model, but modify the operation of the system in some way.

These features may be provided by multiple programs operating on a common database, or by a single program encompassing all of the elements (McMahon and Browne, 1998).

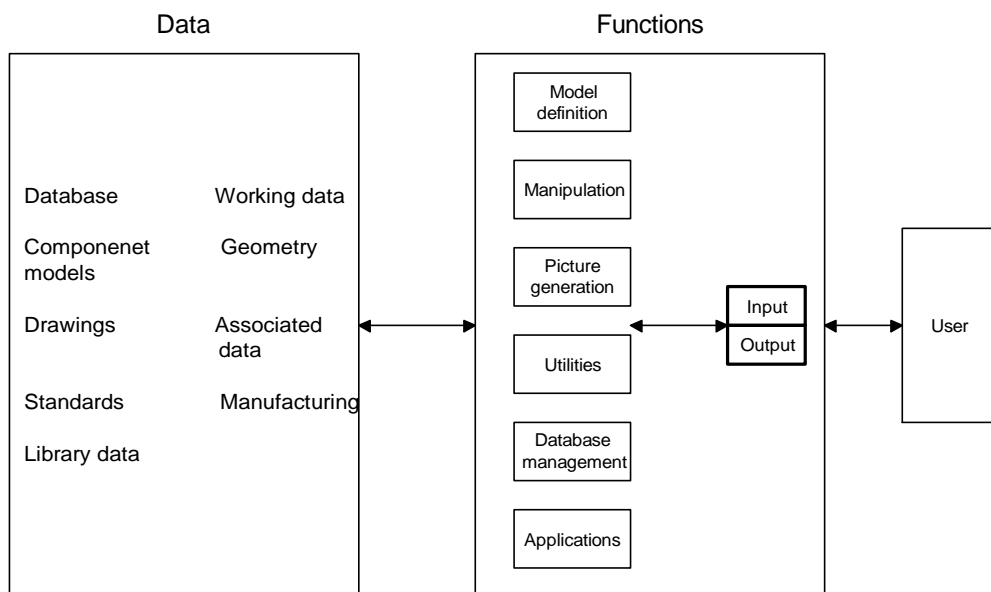

Figure 71: The architecture of a computer-aided design (CAD) system (McMahon and Browne, 1998)

CAD systems are expanding over the years with more elements being integrated into them. Different CAD software packages such as Unigraphics, CATIA, Mechanical Desktop, Pro/ENGINEER, etc. have emerged from the competitive market offering numerous different engineering analysis and simulation capabilities, and new capabilities are continually added into the software. However, conventional CAD systems have been cited as having several limitations for the manufacture of AM products (Hague et al., 2003). The limitations include a time consuming and labour intensive process for translating highly complex design shapes into 3D data (ibid). Within traditional manufacturing processes, manufacturing the tool for production is considered as the most time consuming task. However, in AM there is no tool creation and little preparation for manufacture and hence the longest part of the total manufacturing process is the translation of the design concept into 3D data, i.e. the CAD stage of the process. In addition, conventional CAD systems are poorly suited to representing repeated complex patterns (e.g. surface texture) and multi-material models, both of which are common in AM product designs.

3.9.2 Reverse Engineering

Reverse engineering is defined generally as the process of duplicating an object by taking it apart to see how it works and to enhance its performance (Bagci, 2009). Reverse engineering can be applied in three areas namely software, hardware and in 3D images. Software reverse engineering involves reversing a program's code back into the source code that it was written in, using program language statements. This is done due to retrieve the loss of the source code and to study how the program works.

Hardware reverse engineering involves taking apart a device to see how it works. For example, if a certain machine manufacturer wants to see how a competitor's machine works, they can purchase a competitor's machine, disassemble it and then make a machine similar to it. In general, hardware reverse engineering requires a great deal of expertise and is quite expensive. However, the process of copying or duplicating software programs or hardware may constitute a copyright violation.

Another type of reverse engineering involves producing 3D images of manufactured parts when a blueprint is not available in order to remanufacture the part. Reverse engineering is an important tool with which to generate CAD models. To reverse engineer a part, the part is measured by a coordinate measuring machine (CMM) or a 3D laser scanner (Figure 71).

The data with this process is termed “point cloud”, which represent the unconnected set of points of the object surfaces (Gibson et al., 2010). These points are then connected using RE software such as Geomatics and also used to perform other function such as hole filling and smoothing (ibid).The use of reverse engineering technology not only increases the overall accuracy, but also improves the productivity of the manufacturing process (Bagci, 2009).

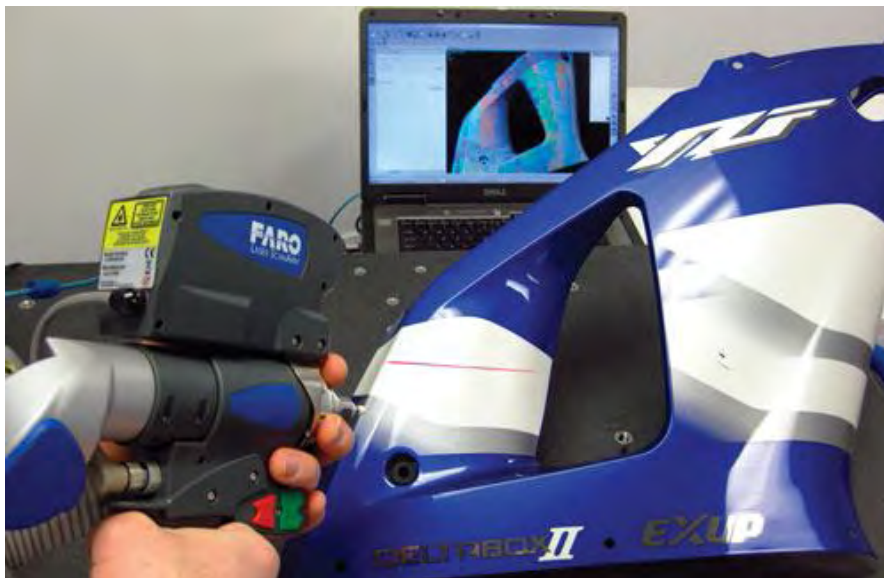

Figure 72: A 3D laser scanning process.
Source : < <http://www.faro.com/SelectCountry.aspx>>27/10/10

3.9.3 Medical Imaging

There have been many application of AM in making models base on human anatomy such as bone structure, ear channels and dental structure construction. Reverse engineering techniques have also been used within the medical sector frequently to obtain the anatomical data. The data is based on 3D scanning obtained from

systems like Magnetic Resonance Imaging (MRI), Computerised Tomography (CT), 3D ultrasound, etc. These data often need to be post processed before it can be represented into an accurate 3D CAD file. Materialise is one of the company that involve in the development of software to importing anatomical data (e.g. scanner data from CT or MRI) into accurate 3D model (Gibson et al., 2010). This model can also be used for further analyses such as Computational Fluid Dynamics (CFD), Finite Element Analysis (FEA), measurement and analysis of porosity etc.

3.10 AM System Selection and Process Support Systems.

This section will describe the examples of AM system selection and AM process support systems that have been developed. Some examples of Design for Additive Manufacturing (DFAM) methodologies have been investigated. Burton (2005) hypothesises that he can manipulate existing Design for Manufacture (DFM) strategies into his own DFAM strategy (Burton, 2005). Providing feedback in a form of a questionnaire to the five areas of AM concern, i.e. production volume, part or product form, product function, product construction and logistics issues confirms that a parts or product is suitable for AM. Burton (2005) suggests generating concepts assisted by profiling statements relative to AM. The statements serve as guidelines and advice as to how to best exploit the benefits of AM. The statements Burton suggests are:

- Utilise freedom of geometric creation
- Part consolidation
- Size variations, eliminate one for all design
- Conformal geometry: user interface customise parts for human interaction
- Conformal geometry: history parts customise parts for interaction with other objects, parts or products
- Range variation and styling: appeal to budget and executive markets
- Integral fixings, mounts and actuators: consolidation of assembly components for added functionality

The final stage is to evaluate all the concepts that have been generated. However, the method could be seen as too general in its approach and involves lengthy questionnaires to be completed at early stages of design. The method lengthens the traditional design cycle and creates more work for the designer. The amount of manually input information on the part of the user, in this case the industrial design professionals, may be a prohibiting factor to the adoption of such a method. Other authors have made statements of what should constitute an AM design methodology. Adding aesthetic quality and consolidating parts are seen as techniques that an AM design methodology should adopt (Hague et al., 2004).

A number of selection tools for RP systems have been developed since 1993 (Masood and Soo, 2002). The selection of the most suitable RP process is dependent on factors such as build envelope, accuracy, material, build speed and other machine related parameters. Previous attempts for RP selection were introduced with a system based on a relational database (Campbell and Bernie, 1996). The system focused on finding the best materials and process combination expressed in percentage values by applying a "Benefit Value Analysis". Later, an RP advisor that was based on relational databases applying MS Access was developed at the Arizona State University (Phillipson, 1997). In contrast, a system to produce the Design for Rapid Prototyping methodology using MS Visual Basic as the user interface and an MS Access database was developed (Jones and Campbell, 1997). The system included system validation achieved by designers' feedback in the required type of performance needed and the suitability of RP thus help to narrow the search for the optimum RP system.

In 1999, the Design Engineering Research Centre at the University of Wales Institute (Cardiff) developed a computer based rapid prototyping design advice system (Bibb et al., 1999). The system works using a knowledge base and an inference engine, using 'IF', 'THEN' and 'ELSE' rules expressed as statements organised as a pattern. This system also incorporated the use of CAD data in the selection process, primarily because the overall design of the system was to be user friendly and so user input was kept to a minimum. The CAD data was interpreted and values inferred from it through calculations from a second program created using Matlab. The resulting values were then used as input data for the main system. Having the

ability to call secondary programs from the main program allowed for less time to be spent coding the system and more time to be spent on the content (Bibb et al., 1999).

In 2001, the Industrial Research Institute Swinburne (IRIS), at Swinburne University in Australia, developed a system named the Intelligent RP System Selector (Masood and Soo, 2002). It is an expert rule based system that assists a user wanting to purchase a RP technology. This is done by asking the user a series of questions relating to their machine specification. The main criteria for selection are price, dimensional accuracy, surface finish, maximum build volume, range of materials, range of layer thickness and speed of build (Masood and Soo, 2002). The selector is programmed with a series of 'IF' and 'THEN' rules based on the knowledge input into the system. The system checks user input against the rules and generates recommendations based on that input. Data for the selector system was gathered from original equipment manufacturers and verified through vendors and users of the technology. For each of the four major selection options, a different basis is used to generate the recommendation:

- ✓ **Quick Selection:** Price, XY accuracy, build volume and material.
- ✓ **Detailed Selection:** Price, XY accuracy, Z accuracy, surface finish, build volume, build thickness and build speed.
- ✓ **Building Technology:** Laser or non-laser system, building process, price, XY accuracy and build volume.
- ✓ **Machine Style:** Office environment, desktop, normal commercial type, price, XY accuracy and build volume.

The selector asks questions of the user giving them options to choose from. The process continues and an appropriate technology is recommended. Along with the technology description, other information is displayed including vendor details. Multiple recommendations can be made by the selector and displayed as a list for the user to choose from. The author also suggests that improvements could be made with the addition of images of the machines and graphs displaying any technical data.

Lan et al. (2005) introduced the fuzzy synthetic evaluation method for the treatment of quantitative data for comparison and weighting purpose by splitting criteria factors into: technology, geometry, performance, economy and productivity considering a couple of factors for each process in order to compare them. The final result provides a RP ranking process similar to previous systems (Lan et al., 2005)

Byun and Lee (2005) describe a RP technology selection system using a modified technique of order preference by a similarity to ideal solution (TOPSIS) method. Like in other systems, the authors use attributes input by the user to determine the suitability of an RP technology for production of an end use model. They used both “crisp” and fuzzy data related to the defining attributes to rank individual RP technologies (Byun and Lee, 2005). The crisp data they used included values for accuracy, surface roughness, tensile strength and elongation. These values were obtained via benchmarking of each RP technology by designing a test part to be produced using each of the RP technologies. Values for the crisp data attributes were taken from these test parts. Fuzzy data which includes model price and build time, have values determined from linguistic terms such as very low to very high. Once the RP technologies have been ranked according to their attributes, the user can generate recommendations on which system to choose by giving weighting factors to the various attributes in terms of the most desirable for a particular model. This presents an easy to use system which can handle both crisp and non crisp data.

Rao and Padmanabhan (2007), discussed RP process selection using a graph theory and matrix approach. Their logical system, like other technology selectors, defines desirable attributes of an RP system as process selection criteria. The interrelations between the selection criteria in terms of their relative importance are modelled in a graph and matrix. The selection criteria they impose are similar to other RP selectors and include dimensional accuracy, surface roughness, tensile strength, elongation, part cost and build time (Rao and Padmanabhan, 2007). In the system, all attributes with the exception of part cost and build time, are given actual values. The attributes used to generate recommendations for an RP technology for a user are the same as the work carried out by Byun and Lee, who determined these attributes through questionnaires with vendors, institutions and bureaus. Part cost

and build time are expressed as a fuzzy value, for example, very high, medium, low, very low. These fuzzy values are quantified through a conversion table that assign an attribute: a value based on a relative scale that starts at exceptionally low (0.045) and ends with exceptionally high (0.995). A user then defines what the most important attributes are that they require for a model produced using a RP technology. The system calculates a value for each technology in the program in relation to the attributes defined by the user, ranking the technologies in order of suitability for the users' purpose and thus making a recommendation.

Most of the systems described so far lack information on cost, materials or build time. Munguia (2008), has depicted a soft computing based system which utilises neural networks and fuzzy logic for the selection of AM systems according to two main specifications: general feasibility evaluation (fuzzy logic based) and cost estimation (neural network based). The system is intended to support designers during the earlier design stage to assess the possibility of using AM for production. However, the use of the neural network still remains an intensive trial and error approach and it is crucial to perform correlation analysis to input data in order to evaluate its real cost beside training and validating the networks.

Kruf et al. (2006) published ongoing research on Design for AM of functional LS parts that focus on materials properties and reproducibility (Kruf et al., 2006). Using a 3D CAD software, an initial 3D model was created. According to the specifications, the bounding box, frozen elements and the applied forces were defined and used as input for the Computer Aided Optimisation (CAO) software. Within the CAO software the soft kill option (removing non-efficient material) and Finite Element Modeling analysis of the initial design were performed as shown in Figure 72. According to the authors, to obtain an optimal design, all the requirements below must be well determined to obtain a useful output file and end product.

- i. Determine the correct frozen elements.
- ii. Set bounding box.
- iii. Specify the forces on the features
- iv. Determine the correct material properties

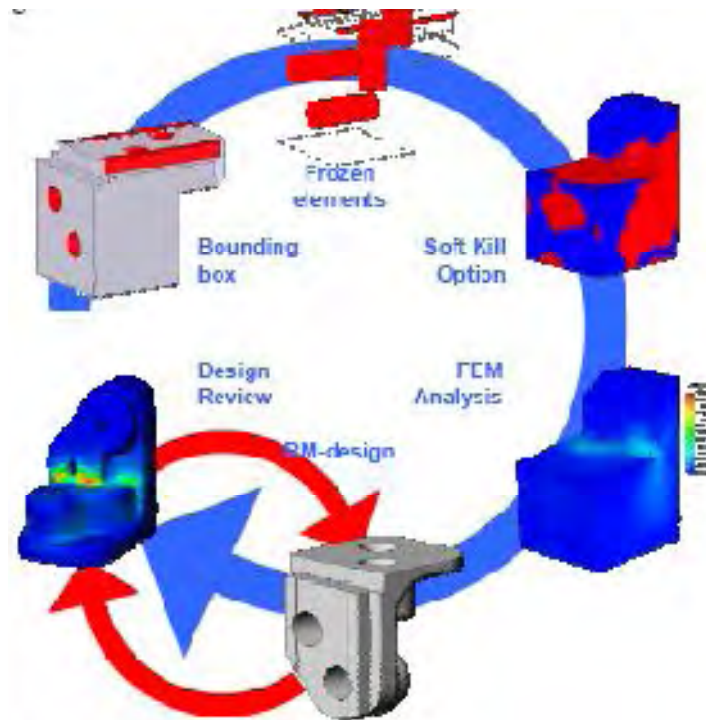

Figure 73: From conventional design to AM.
(Kruf et al., 2006)

Besides shape optimisation and weight reduction several other features are incorporated within the design. With LS it is not possible to create functional (metric) threads. Therefore inserts, originating from injection moulding, are integrated into the design as shown in Figure 73. By adding ventilation holes in the design, air is able to escape during the placement of the insert and redundant material can flow away. The highest strength and most optimal stress distribution are assured when built in the correct direction. The research concludes with a simple yet illustrating example of the application of AM using an intelligent design approach.

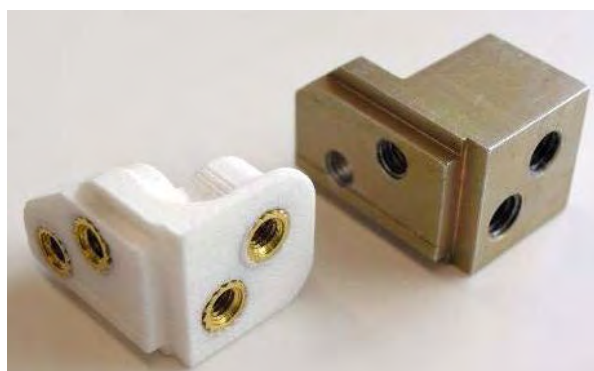

Figure 74: The LS part and the original bracket.
(Kruf et al., 2006)

Ziemian and Crawn (2001), developed a computer aided tool for decision support for a Fused Deposition Modelling system that allows part outcome preferences to guide the recommendation of process variable settings. The system directly integrates design data and designer build preferences with FDM fabrication knowledge (Figure 74). The design information is extracted from the CAD solid model of a dimensioned and toleranced part, and the designer build preferences are obtained from the machine user (Ziemian and Crawn, 2001).

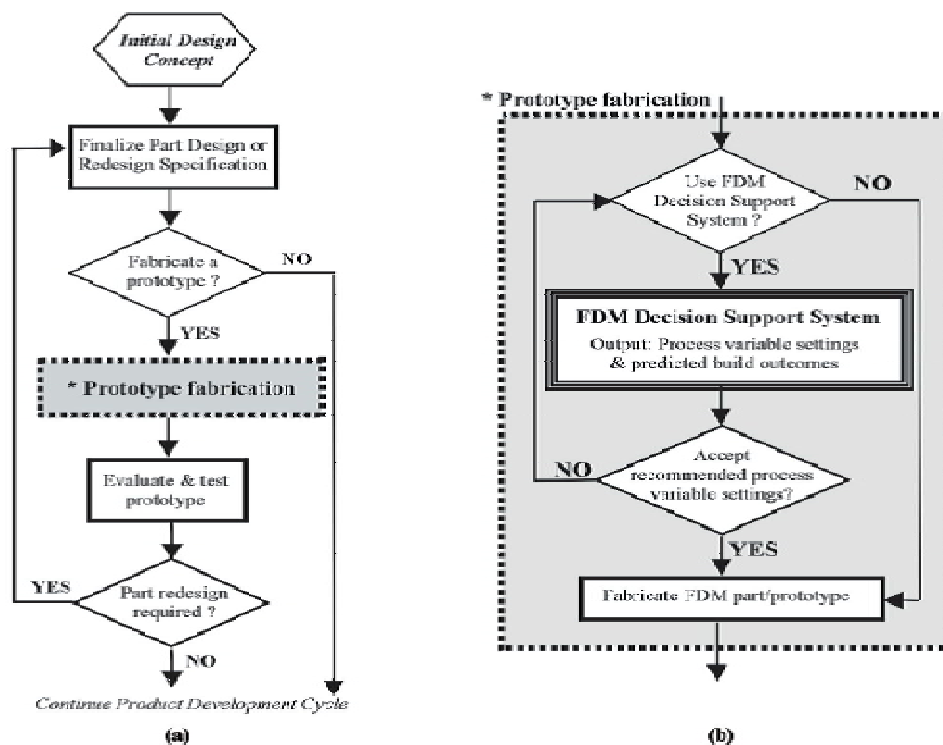

Figure 75: (a) Placement of prototype fabrication within design process and (b) FDM decision support system in prototype generation.
Source: (Ziemian and Crawn, 2001)

The system generates recommendations for process variable settings and the associated predicted build outcomes. These results can then be used to evaluate the appropriateness of the impending part relative to its intended use, i.e. prototype for marketing, functional test, or form/fit evaluation, rapid tooling, or rapid manufacturing. System feedback provides the designer with pre-fabrication data for design evaluation, and a relatively quick and inexpensive opportunity for potential redesign. This work included consideration of part orientation or build directions, support structures, layer thickness and layer path planning for optimising build time, surface finish, dimensional accuracy, or part strength. The optimisation problems were

solved using MATLAB software and the decision support methodology was iterated manually as shown in the structure (Table 11).

<u>FDM Decision Support System</u>	
Given:	<ol style="list-style-type: none"> 1. Design specifications <ul style="list-style-type: none"> • CAD model • Dimensions & tolerances • Surface finish requirements 2. Candidate build orientations 3. Designer/user build preferences <ul style="list-style-type: none"> • Ranked list of build goals
Determine:	Process Variable Settings <ul style="list-style-type: none"> • Build Orientation • Layer Thickness • Road Width • Interior Fill Strategy
To Optimize:	User's primary build goal
Subject To:	Secondary Build Goals Build (Design) Constraints FDM Machine Constraints

Table 11: Structure of decision support problem.
Source: (Ziemian and Crawn, 2001)

Page at el. (2005) demonstrated the automated generation of 3D CAD data using coded pattern projection and laser triangulation systems. Figure 75 shows the traditional RP process chain and the inclusion of the 3D scanning system.

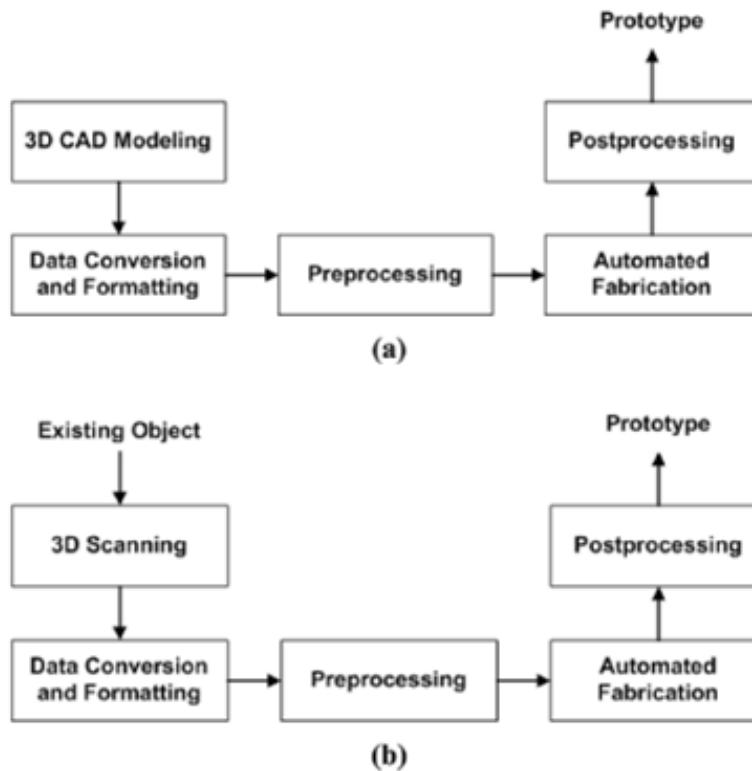

Figure 76: (a) Traditional RP process chain (b) Inclusion of 3D scanning system.
Source: (Page et al., 2005)

Figure 76 show that the laser triangulation uses a laser source and a charge-coupled device camera to construct the 3D measurement of the object. This research has demonstrated the generation of 3D models using these two systems and claimed that the imaging-based scanners offer the potential to enhance the RP process by providing faster and more automated methods to generating CAD models.

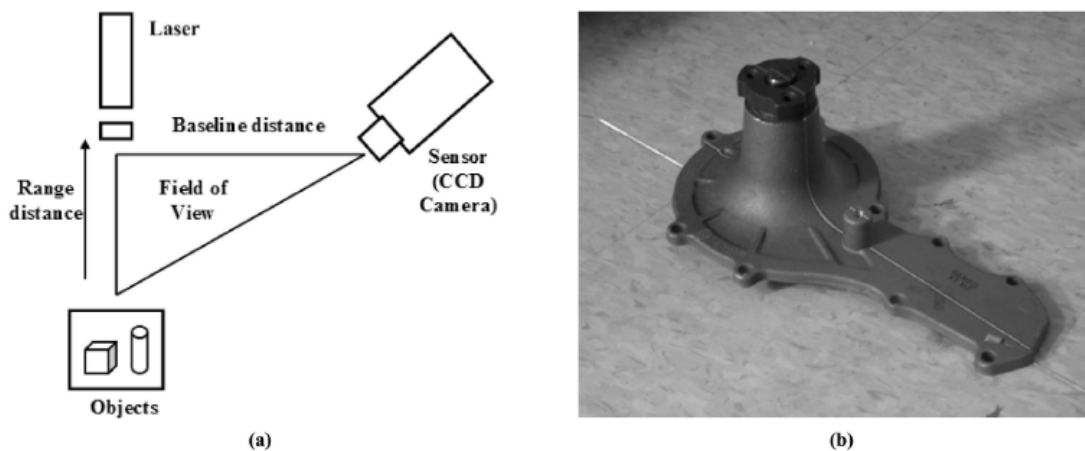

Figure 77: (a) Line drawing of the laser, CCD camera and the object (b) laser line projection on the part.
Source: (Page et al., 2005)

Part deposition orientation is a major factor for AM as it effects build time, support structure, dimensional accuracy , surface finish and cost of the end product (Pandey et al., 2007). The automation of orientation selection process eliminates the operator's involvement and hence reduces possible errors. Many attempts have been made to decide a suitable part orientation deposition using different criteria. Frank and Fadel (1994), suggested that many factors are affected by the part deposition orientation. They considered three factors, namely surface quality, build time and amount of support structures, to obtain a better part deposition orientation. Surface quality was considered as the most important factor because the functional requirements of the prototype have to be satisfied (Frank and Fadel, 1994). They used minimisation of stair stepping as a criterion to find the orientation that gives better surface quality. Stair stepping being the geometrical constraint of AM, it cannot be avoided but a user may be given a facility to orient the part in a direction that minimises the stair stepping effect on a critical surface.

Surface finish is more important than the speed of part building, however, build time can be taken as a criterion when a part is needed immediately (Frank and Fadel, 1994). Support structure was given least preference among the three considered factors since it is an intrinsic part of the AM processes, even though it is important to consider as the post-processing and finishing steps depends on the volume of support structure. They minimised the area of downward facing triangles (STL file) of the part to minimise the support structure rather than minimising the actual volume of the support structure. They described orientation rules for better surface quality based on the two most important features present on the part. The relative orientation of these two geometric features can be parallel, perpendicular or at some angle. The following rules were framed to achieve better part surface quality:

- If the feature axes of two surfaces of revolution are parallel, orient the feature axes in the z-direction.
- If the feature axes of a hole and a freeform surface are perpendicular or at an angle, the orientation of the feature axes is not well understood.
- If the feature axes of a surface of revolution and an inclined plane are perpendicular, orient the feature axis of the surface of revolution in the z-direction and orient the feature axis of the plane perpendicular to the z-axis.

Cheng et al. (1995) presented an approach for determining suitable part deposition orientation for SLA parts considering dimensional accuracy as well as build time as objectives. Part accuracy was treated as the primary objective and was estimated using different weight factors for different types of surface geometries. Various sources of fabrication errors like tessellation, missing feature information due to slicing, over curing, distortion and shrinkage, container effect and stair stepping etc. were considered in determining these weight factors (Cheng et al., 1995). They considered fourteen types of surfaces and features and assigned weights to them based on experience. The secondary objective was to minimise build time and it was achieved by reducing the number of slices. Possible base planes were first identified by finding the planar (flat) surfaces of the object. First, a few orientations were short-listed based on part accuracy considerations and later one or two suitable orientations were selected by minimising the build time.

Xu et al. (1997) have sought to obtain the optimal orientation with adaptive slicing for part building in SLA systems. In their algorithm, the building time, accuracy and the part stability are considered. A generic algorithm was employed to find the maximum layer thickness within a given height tolerance (Xu et al., 1997).

Lan et al. (1997) determined part deposition orientation for SLA parts based on the considerations of surface quality, build time or complexity of the support structures. Surface quality was evaluated either by maximising the area of non-stepped surfaces or by minimising the area of worst quality surfaces. The maximisation of area of non-stepped surfaces was achieved by selecting a part deposition orientation that maximises the total area of perpendicular and horizontal faces, which do not offer stair stepping (Lan et al., 1997).

Yang et al. (2003) have proposed feature-based process planning techniques for orthogonal deposition manufacturing system. The aims of the feature base process planning is to improve the process efficiency by reducing the need for support structure and minimize the staircase error by application of lateral deposition (Yang et al., 2003). However, this method is only applicable to a limited number of feature types that has been defined for the study. Therefore, more features for different applications should be defined to verify its usability.

Pandey et al. (2004) have determined optimal part deposition orientations using a multi-criteria genetic algorithm by considering build time and average part surface roughness as two objectives simultaneously for FDM. The optimal orientations are selected among all possible orientations instead of a list of pre-selected orientations (Pandey et al., 2004).

3.11 Summary

In this chapter an introduction has been made to the field of AM. AM is seen as having matured during the last decade to develop into a key engineering tool in the product development process. Advances have been made in the systems used, the build materials and the resolution of the processes to create fully functional AM parts and products with complex geometry for various applications. The principle advantage of AM is that it is capable of manufacturing without the need for tooling and this has led in the use of AM becoming a reality for the manufacture of end use products. However, the literature that offers information on design guidelines and requirements for AM is lacking. Without substantial investigation by the designer it is difficult to redesign a part or product for AM with any degree of confidence that it will work throughout the product's life. To overcome its limitations and to realise the full extent of the benefits of AM, industrial designers need to be taught how to design for the process.

The literature review also found that the advantages of using AM are currently not very well understood by most industries. Therefore, finding new market opportunities for adopting AM could be a very important route to commercial success. However, the effort required to identify suitable products that could be switched from traditional manufacturing to manufacture by AM technology must be taken into account. Finding a relatively small product with high value added personalisation features that are difficult to manufacture with conventional technology is a sensible strategy for adopting AM technology.

This chapter has explored and discussed the general overview of the various tools to generate CAD models for AM processes and the decision support systems, tools and techniques to support the design process. Various CAD data development systems and tools have been explored. Furthermore, various expert systems technologies that support decision making processes have also been explored. Conclusively, CAD and reverse engineering technology are the most well known CAD data development systems. In addition, expert systems are the most well known decision support tools that have been used for various applications. Having become widely used for a broad range of applications, elements of an expert system could be considered to have the capability to be part of a design aid tool for AM.

The result of the review reported in this chapter also indicates that AM has been identified as a new and developing area of technology for which little instructional material and few design aids exist. Having identified this gap in knowledge, it is the aim of this research project to recommend a suitable method that will assist industrial designers in the generation of product designs for AM.

Chapter Four: Design Factors to Consider for AM

4.0 Chapter Overview

This chapter presents two empirical studies. The first study is to identify the key drivers or reasons for AM utilisation and to ascertain the challenges for industrial designers when designing of parts or products for AM. It is intended that this study will provide insight into the needs of a design aid tool for AM. This study also is intended to describe which aspects of design support should be provided by the tool and identify the best strategy that should be adopted within the tool to provide this design support.

The second empirical study investigates the tools, techniques and methods employed by professional designers when designing part or product for AM. This study was also aimed at gaining an insight into the innovative design features that professional designers create in order to meet their design specifications when utilising AM systems. This “expert knowledge” will form a vital part of a DfAM tool.

4.1 Research Methodology for Preliminary Investigation Number One

It is important that before the main study took place, some fundamental research questions should be answered to enable concentration on a specific scope and later in-depth investigation of that scope. The research methods employed was a design case study (recorded through the use of design diaries) and by using an open ended questionnaire. The use of a design case study is in accordance with the applied nature of the research, since the provision of a design aid tool or design method is the main focus. The open ended questionnaire provides a means to investigate the participants’ opinions and to assess the need for the proposed design tool or method. Nine postgraduate students on the Industrial Design Masters Programme at Loughborough Design School (intake year 2009) were given a project to re-design a user-interaction product so that it could be produced by any commercially available AM system. The guideline for the project is shown in Table 12.

CAD Modelling Project Brief

Background:

Many consumer products are designed to be manufactured from several injection moulded external components enclosing a number of internal mechanic/electronic working parts. The time to market will be determined by tool manufacture, and manufacture and assembly of the product will be compromised by the need for design for manufacture and assembly (DFMA) of the component parts and their associated fittings. However, with the advent of additive manufacturing (AM), many of the limitations imposed by DFMA have been removed, thus giving greater freedom to the designer.

Assignment:

Consider a user-interaction product of your choice. Develop a re-designed concept that fits the design for AM approach outlined above, and that will require a combination of surface modelled and solid modelled parts (i.e. freeform, organic external form coupled with more regular shaped internal components).

You will use the Pro/ENGINEER CAD system to model the internal components of the product and Alias Wavefront Studio Tools system to model the external form. Your final design will be represented as a single combined 3D CAD model. Associated 'downstream' outputs that have exploited the CAD model will also be generated.

Submission Requirements:

1. A 3D CAD model file, as a number of component parts (minimum of five), including some internal components in addition to the external shell. The CAD modelling should reflect appropriate use of Class A surfacing features and also solid modelled features. This should be submitted as a series of files on a CD ROM.
2. Evidence of downstream activities that have been undertaken using the completed CAD model. Specifically, these will comprise - a rendered image of the product in its normal use environment (saved as a jpeg file) and an STL file of the shell component(s).
3. A written report of approximately 1500 words (excluding appendices) that describes and discusses the following:
 - A description of how commercial designers, product developers and manufacturers have adopted 3D CAD modelling in their product design development. Use case studies to illustrate the principles and practices that you have identified.
 - A stage-by-stage description of the CAD modelling approach you have adopted. This should describe the modelling rationale and reasons for selecting different types of features, tools and software packages.
 - A justified choice of the AM process and material to be used, a cost-benefit analysis for using AM (which must include an estimate of the numbers to be manufactured) and the temperature range that your product can be used in.

Table 12: Guideline for the project

The students were regarded as novice, yet competent industrial designers who were not previously conversant in the principles and benefits of AM. Therefore, prior to commencing the project they were given a one-hour lecture on AM, which included introduction to AM, types of AM systems, applications of AM, advantages and limitations of AM and numerous examples of products that had been designed and produced by AM systems.

The students were required to use the Pro/ENGINEER Wildfire 4.0 CAD system to model the external form and the internal structure of their chosen consumer product as this would allow them to complete the task in ample time. The final design was to be represented as a single combined 3D CAD model with STL files of the individual components also being generated. For each student, the total time to be spent on the design project was in the order of 70 hours. Throughout the project, the students were required to keep a “design diary” to explain and justify the design decisions taken with respect to AM. This included the choice of AM process and material to be used, the rationale behind AM-enabled attributes that were included in the product (e.g. customisation, parts consolidation, etc.) and their inspiration for specific “design for AM” features, i.e. were they seen elsewhere or did the students think of them independently.

Following the submission of the assignment according to the requirements stated above, an open ended questionnaire were given to each student to obtain information on various challenges and issues pertaining to designing for AM. Table 13 shows the questions. The questions were developed base on the objectives of the study i.e. to understand the students’ reasons for using AM, how they develop product design for AM and to understand their challenges to design for AM. To ensure the validity and clarity of the questions, the questions were pretested with the author’s supervisor who is an academic within Loughborough Design School. As a result, minor changes to sentence structure of the questions were made.

1. Briefly describe the product you have selected for this project.
2. What are the specific reasons that the product you have chosen needs Additive Manufacturing (AM)?
3. What are the factors to consider when designing the product for the reason(s) stated above?
4. Where did you get the information to support your designing for AM?
5. Which AM system you choose for this project?
6. What are the current major challenges to design product for AM?
7. Are your current AM knowledge and design skills adequate to cope with future industrial requirements?
8. If there is a tool/system/method to guide the design process for AM product how can it guide or assist the overall AM design process?
9. If there is a tool/system/method to guide the design process for AM product, how could it guide or assist you before the conceptual stage of the design process?

Table 13: Interview Questions

4.2 Questionnaire Findings

The records of the information from the questionnaire are shown in Appendix A. The main findings from each question (excluding question 1) are summarised below.

4.2.1 AM reasons for utilisations (Question 2)

The questionnaire began with investigating the specific drivers that made the selected product suitable to be designed for and manufactured by AM technologies. There were six reasons identified by the students as to why their product was suited to manufacture using AM. The students' justification and approach to each of these is discussed below.

4.2.1.1 Part geometric complexity (Identified by 4 students)

The foremost benefit of AM that the students noticed was AM's ability to manufacture geometry of virtually any complexity without the need for tooling. The students' responses showed that they recognised that AM parts can have variable wall thickness and have no need for draft angles. They also recognised that parts do not need parting lines and that they could therefore avoid witness marks, as would typically be caused by mould tool splits, feed points or ejection pins (particularly useful from an aesthetic point of view). It was also noted that parts could be produced with re-entrant features and undercuts that would be impossible to extract from a mould cavity.

The ability to produce complex product geometry, provided that they could design it within a CAD system, gave the student designers the means to enter into what has been called "Manufacture for Design" rather than the conventional method of design for manufacture (Hopkinson et al., 2006). Some of the students were able to grasp this potential more readily than others. Figure 77 shows an example of a student design that exhibited particularly complex geometry.

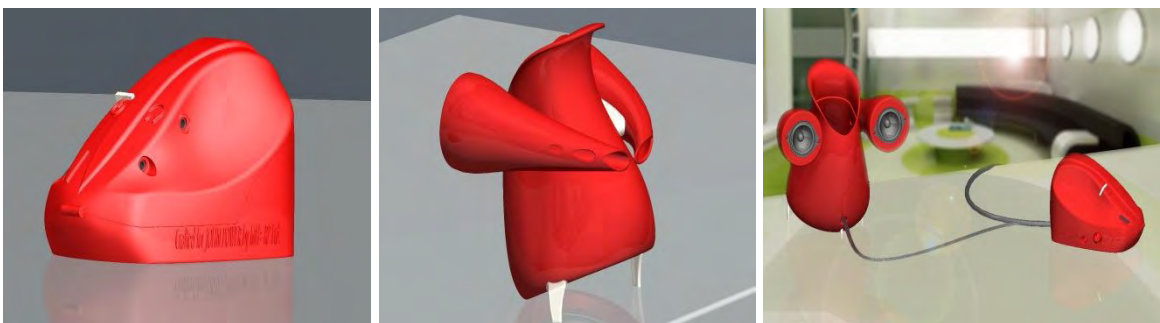

Figure 77: Speaker system redesigned for AM

4.2.1.2 Form or aesthetics requirement (Identified by 7 students)

A related benefit of AM that two students recognised was the ability to support the creation of highly aesthetic shapes, not only for end use products but also for artistic pieces. In this respect, several students were aware of the work of Freedom of Creation with products such as lighting, fashion accessories and “lacework” stools that could be accessed from their website at www.freedomofcreation.com.

4.2.1.3 Ease of parts consolidation (Identified by 8 students)

Another justification for the use of AM was that it provided greater ease of parts consolidation. Students recognised that the ability to produce parts of increased complexity provided greater scope for the merging of multiple assembly components, allowing the production of highly complex multi-functional single parts. Parts consolidation was seen as a natural extension of the newfound freedom of design. In some cases students were able to re-design the product so that buttons, switches, covers and straps were incorporated into the main product body (for example, the multi-meter shown in Figure 78). The ideal design was seen as one that would completely eliminate the assembly process by consolidating all parts into one component. Current AM systems could not accomplish this. However, it is likely that future development of multi-material systems will enable this. The students indicated that they saw the ability of AM to consolidate parts as having a positive impact on time, cost and quality of product manufacture.



Figure 78: Multi-meter redesigned for AM

4.2.1.4 Use of multi or dual material within a single component (Identified by 1 student)

The questionnaire also showed that two students appreciated that an important area of development taking place with the AM field is the use of dual materials within a single component. An obvious example of the benefit of such manufacturing would be the reduction of production development cost and cycle time associated with dual-shot injection moulding. These students designed their product to take advantage of the “plastic/elastomer” combination available from the Connex500™ machine from Objet Geometries. Figure 79 shows a toothbrush where the grip material was to be built into the main casing.

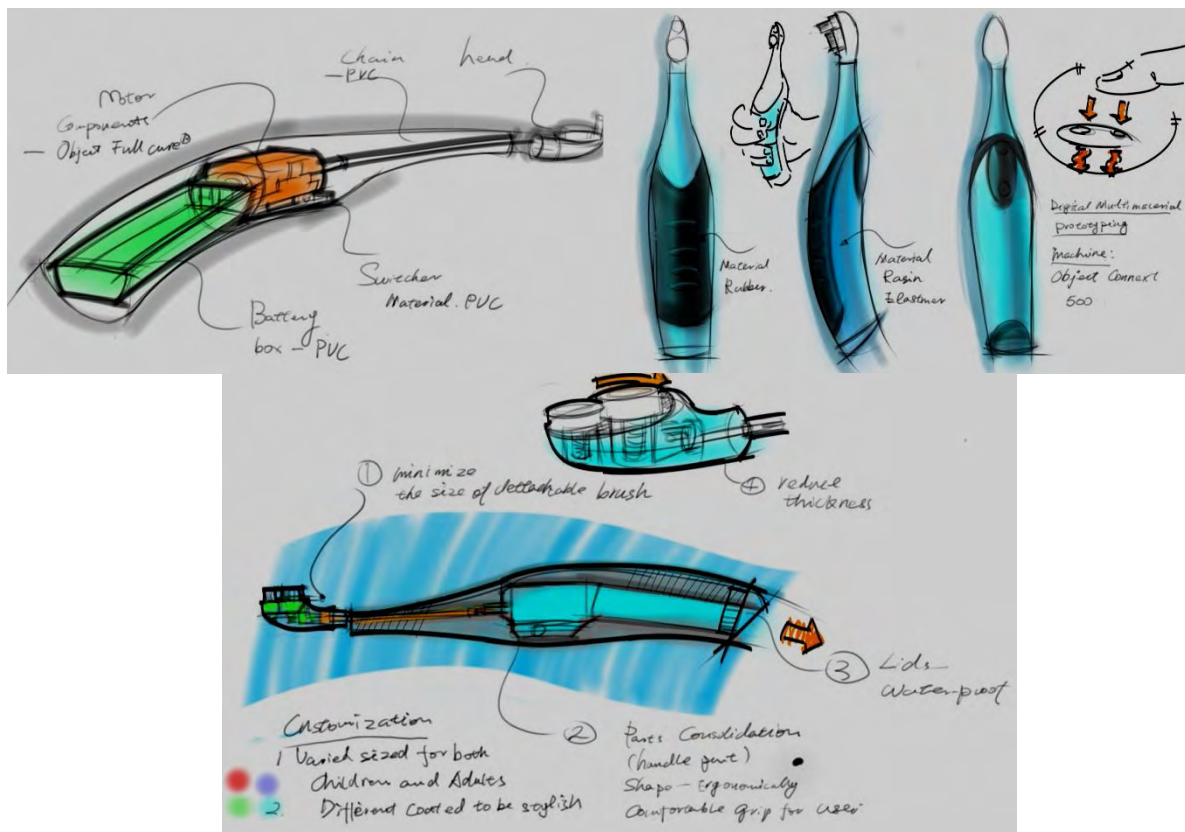

Figure 79: Toothbrush redesigned for AM

4.2.1.5 Low volume production requirement (Identified by 1 student)

The questionnaire also found that one student was aware of the low volume production capability of AM. This made it possible for him to design his product to meet the needs of smaller segments of a market. The student also recognised that if AM parts were rapidly produced to order then it could reduce the need to predict how many parts to keep in storage, as they could be made on demand from a stock of raw material. Besides reduction in storage costs, AM would also be able to respond to changes in sales forecasts or manufacturing schedules.

4.2.1.6 Personalisation or customisation requirements (Identified by 8 students)

The last AM driver identified by the students was the economic feasibility of producing “one off” items and products that are unique to individual user requirements. An example of customisation with regards to the project undertaken by the students is shown in Figure 80. The watch was designed to accommodate the exact requirement of user wrist geometry variation. It was realised that with the ability to customise the product would come an increase in the level of ergonomic match and comfort.



Figure 80: Wrist watch redesigned for AM

4.2.2 Design Factors to Consider for AM (Question 3)

Due to the ability to manufacture greater geometrical complexity, the students realised that design for AM requires abandoning normal guidelines for designing such as those followed for the design of injection mould tools. Furthermore, they also identified the feasibility of totally removing fasteners and replacing them with other snap fit mechanisms such as those seen in mobile phones. This approach was used in the multi-meter in Figure 78 where the student claimed that parts consolidation should bring significant assembly cost savings. However, the requirement to link parts together and to insert and hold internal parts in some of the electronic products was difficult for some of the students to achieve. The students said that design of AM products has to be based on the characteristics of the specific AM process used as this would determine materials, accuracy, support structures, build orientation, mechanical properties, cost/time, quality, process parameters and minimal wall thickness. Functionality of the product was most often stated as the most important aspect to be considered, however another factor to be considered was the enhancement of the aesthetics element of the AM product. Some of the students applied reverse engineering principles in which they dismantled all the parts of the existing product, analysed them and redesigned the product for AM. In addition, one student responded that a possible approach that could be utilised for AM is “designing by trial and error”, i.e. learning from one’s previous failures.

4.2.3 Sources of Information Used to Redesign for AM (Question 4)

The questionnaire found that most of the students relied heavily on generic AM material from various websites such as:

- ✓ <http://home.att.net/~castleisland/> (8 students assessed)
- ✓ <http://www.3trpd.co.uk/> (5 students assessed)
- ✓ <http://www.rapidprototypinghomepage.com/> (5 students assessed)
- ✓ <http://eu.redeyeondemand.com/Default.aspx>. (2 students assessed)
- ✓ <http://www.freedomofcreation.com> (2 students assessed)

Others sources that the students depended on were general AM books such as:

- ✓ Rapid Prototyping: Principles and applications by Rafiq Noorani. Hoboken, N.J. : Wiley, 2006. ISBN: 0471730017.
- ✓ User's guide to rapid prototyping by Todd Grimm. Dearborn, Mich.: Society of Manufacturing Engineers, 2004. ISBN: 0872636976.
- ✓ Rapid Prototyping : Principles and Applications by Chua C. K., Leong K. F. and Lim C. S, Singapore, : World Scientific, 2003. ISBN: 9812381171
- ✓ Hopkinson, N., Hague, R.J.M. & Dickens, P.M. 2006, *Rapid Manufacturing : An industrial revolution for the digital age*, John Wiley, Chichester, England.

The students were seemingly not able to find specific resources to support the design of their intended AM features such as a guide to consolidating parts, a guide for designing complex geometrical parts or a guide for suitable AM materials for their required application.

4.2.4 Choice of AM System (Question 5)

The questionnaire showed that the students understood the selection of an appropriate AM system often depends upon a particular product requirement. Typical factors they considered were the product's surface finish, its strength, and the accuracy needed. Most of the students had selected SLA as the suitable AM system because of its capability to produce very good surface finishes compared to some other processes. They also recognised that SLA can provide good accuracy that enables the fit and form of detailed internal parts to be designed with confidence. The type of products chosen will not be subjected to heavy mechanical properties and thus the moderate strength provided by the SLA system was seen as justifiable.

4.2.5 Challenges to Designing Parts or Products for AM (Question 6)

Whilst the ability of AM to create practically any geometry provided the student designers with much freedom, it was noted that certain constraints still affected the design of AM products. In total, seven challenges were associated with designing for AM. These are listed below:

- i. Difficulties in translating desired design features into CAD geometry due to the increase in part complexity.
- ii. Time consuming design process because of the need to understand AM capabilities, the type of AM systems available and the availability of suitable materials to meet the mechanical and physical properties. This was due to the current absence of a tool to support or guide designers.
- iii. To meet the requirement that AM is only suitable for low volume production.
- iv. AM product design has to compromise with limited product colour selection options.
- v. Limited types of material properties which could result in poor mechanical performance of the product.
- vi. Difficulties in constructing the internal structure of parts so as to accommodate other components and parts such as circuit boards etc.
- vii. Constraints on the CAD capabilities of the students and on not having had the opportunity to experience AM product development practically.

Clearly, some of these challenges are related directly to the experience level of the student designers. However, others would be encountered by any designer considering the use of AM.

4.2.6 Analysis of AM Knowledge and Design Skills (Question 7)

Responding to the question on their design knowledge and skill requirement, only one student identified that he was equipped with the AM knowledge and design skill needed to cope with future industrial requirements (i.e. working in an environment where AM has become a “mainstream” production process). All the other students said that they were currently not well equipped, despite the fact that their knowledge had been increased by the design project.

4.2.7 Suggestions for a Design Aid Tool for AM (Questions 8 and 9)

There were numerous suggestions given by the students concerning a tool or method that could be developed to overcome the issues stated in Section 5.2.5. These are listed below:

- i. Tool that gives user an overview of each AM process and its benefits and limitations.
- ii. Assistance in analysing the suitability of design concepts for AM.
- iii. Graphic or image database or library of achievable forms, videos of AM machines in action, library of part consolidation examples, e.g. built-in buttons.
- iv. A tool that allows greater understanding of the internal structures of parts.
- v. A tool or system that could coach and guide the AM design process.
- vi. A CAD based tool to support AM specific geometry perhaps based around complex 3D forms, e.g. diatoms, sea shells.
- vii. A tool that could remind designers about the key points that they should pay attention to and offer references and resources.
- viii. Video on AM designing activity.
- ix. Provide information on types of suitable AM materials and AM systems available.
- x. Assistance on free formed shape modelling to reduce the time and difficulties for designers.
- xi. Having a system within the CAD package which would highlight any foreseen AM problems e.g. gaps, material selection difficulties.
- xii. Simulation tool to check the possibilities of manufacturing using AM.
- xiii. Specific material library with properties but also with suitable materials for dual material manufacturing.

Some of these suggestions are beyond the scope of the current research as they deal more with AM process selection and material selection. However, this research aims to concentrate specifically on assisting industrial designers to develop product that are suited to pre-defined AM systems. Many of the suggestions have a direct bearing upon this aim.

4.3 Analysis of Design Diary

In this study, the reports in the students' diaries were supposed to reveal their thought process during the design stages. To some extent, the process of decision making during the redesign processes was unable to be analysed. The students felt that the use of a design diary was time consuming to organise and manage. Consequently, the quantity of data provided by the design diaries was disappointing.

4.4 Summary of Findings (Preliminary Investigation Number One)

With the emergence of various AM technologies, designers are faced with a requirement to understand the limitations and capabilities of each AM system. Only then will they be able to take full advantage of the new design capabilities that are on offer. This is currently a daunting task for the designer due to the lack of literature or design support tools. The findings of this study have indicated some of the design issues and challenges that are faced by industrial designers when striving to design for AM. They have also shown that there is a desire, at least amongst student designers, to see a DfAM tool that will be of practical benefit to industrial designers. It is clear that the type of DfAM features incorporated into product designs will be influenced by the type of AM system being considered, the material to be used and various other factors. To provide a design support tool for all the available AM systems would be challenging and so the research will focus initially on LS part or product.

4.5 Preliminary Investigation Number Two

This section describes the second empirical study conducted during the research. In order to capture the tacit knowledge of professional designers who currently design for AM, a semi-structured interview approach was used to elicit their goals and needs by focusing on how they performed design for AM tasks on specific products that they had developed. This chapter reports the findings from interviews with five experienced designers with reference to their respective AM enabled products, which exhibit geometric complexity, parts consolidation and product customisation. This information is then used to define their cognitive model and to outline the nature of the proposed DfAM tool.

There were three main objectives of the study:

1. To investigate the designers' procedural knowledge for designing AM products or parts.
2. To investigate the type of design features created in these products that represent creative solutions for AM enabled design.
3. To identify the best strategy that can be adopted within the proposed DfAM tool to provide the necessary design support.

4.6 Overview of Preliminary Investigation Number Two

This study represents an initial attempt at gathering, presenting and disseminating design knowledge required particularly for AM enabled products. The aim of the study was to examine how AM products are developed and to analyse the procedural design knowledge found. The study addressed the need to develop insight into the design thinking of professional designers and to understand their design processes and procedures so that these could be captured and reused in a manner that will assist other designers in designing for AM.

Capturing and analysing design activity is complicated because of the nature of the work. For instance, designers are not restricted to be at a particular place undertaking their development of design work. Thus, it is impossible for the

researcher to be with the designer every time they engage in their design activity. Protocol analysis has not been used for this study due to the complexity of the products. Moreover, protocol analysis can be obstructive when it requires the respondent to verbalise their thoughts and it is time consuming as it requires transcribing and coding the data. Due to these reasons, AM products examples and interviews were used as a research strategy to explore designers' perception, knowledge and rationale in AM-enabled product design.

4.7 Research Methodology of Preliminary Investigation Number Two

Semi-structured interviews with five professional designers were used to elicit their goals and needs by focusing on how they performed design for AM on specific products that they had developed previously. All of the designers were experienced (with at least five years of professional practice) and all had recently created product designs that were aimed at exploiting the benefits of AM. They were identified through published case studies of their work, which had appeared in AM related conference proceedings or journals.

Originally, it was envisaged that more designers would be interviewed but there were relatively few published examples of product designed for AM and several potential participants did not respond to the author's emailed invitation. Six main reasons was identified by previous studies as to why a product was suited to manufacture using AM as listed below (Maidin S. 2009) & (Burton 2005):

1. Parts' geometric complexity, e.g. internal structures.
2. Form or aesthetic requirement.
3. Ease of parts consolidation.
4. Low volume production requirement.
5. Personalisation or customisation requirements.
6. Use of multi or dual material within a single component.

By capturing and analysing AM design experts' opinions on various aspects of designing for AM, this would enable future recall of their practical design procedures and making this knowledge explicit. The examples of product designed for AM which

formed the basis of the interviews covered several, but not all of these reasons (as shown in Table 14). This is due to limited number of designers to participate in the study.

No	Designers	Affiliation	Case Study Product	Specific AM Reasons
	Paul Du Plessis	Saab Aviatronics, South Africa	Avionics Enclosure	Parts Geometric Complexity & Low Volume Production
1.	Peter Sever	University of Maribor, Slovenia	Automotive Active Ventilation System	Parts Consolidation
2.	Carlos García Pando	Prodintec, Spain	Medical Surgery Tools	Product Customisation
3.	Olaf Diegel	Auckland University of Technology, New Zealand	Customized Golf Club Grips	Product Customisation
4.	Mike Burton	RMIT, Australia	Automotive Dashboard Console	Parts Consolidation & Low Volume Production

Table 14: List of designers and their respective products designed for AM

In general, a guideline of seeking designers with a minimum of 5 years experience was used. The semi-structured interviews consisted of five main parts:

1. Introduction and explanation of the interview process.
2. Description of the product designed for AM.
3. Description of the design procedures involved.
4. Elicitation of specific AM design features, issues and challenges.
5. Exploration of ideas for the DfAM tool format.

The objective of each interview was to elicit and gain insight into the design possibilities offered by AM with all the emerging creative solutions used. It was also to understand the knowledge and skill of the designers with regards to their design activity carried out with reference to their respective AM product. The interview questions were developed base on these objectives. Table 15 shows the specific interview questions used. To ensure the validity and clarity of the questions, the questions were pretested with the author's supervisor who is an academic within

Loughborough Design School. As a result, minor changes to sentence structure of the questions were made.

The study was initiated by sending emails with the set of questions attached and requesting the designers' permission and cooperation to be interviewed. After reaching an agreement of a suitable time, the interview was conducted via telephone and the conversation was recorded. The interview was conducted via telephone due to the international locations of all the designers making it impractical to have face to face interviews. Each interview sessions were conducted within 30 minutes. The results obtained from the interviews are described in the following sections.

- | |
|--|
| <ol style="list-style-type: none">1. Can you briefly describe your current role at this organisation?2. Can you describe the product that you designed for AM e.g. how did it originate, was it a new product or a redesign of an existing product, how many people were involved in its design?3. Why did you choose AM to manufacture this product i.e. was it for parts consolidation, customisation, aesthetics, complexity or some other reason(s)?4. Can you explain briefly the procedure of designing this product?5. What specific design feature(s) does your product have that is/are particularly suited to using AM?6. For each feature, where did you get the idea for this design feature, was it your own original idea, did you see something similar elsewhere, where you inspired by nature, etc.?7. For each feature, were there any specific AM-related issues that had to be considered for this design feature e.g. layer thickness, minimum feature size, accuracy, removal of supports, surface finish, etc.8. Can you recall any particularly creative solutions you used to cater for these AM issues?9. What AM system did you use to manufacture this product and why?10. What were the skills and knowledge that you needed to design this product effectively to be manufactured with the AM system?11. What would you say are the most significant challenges for designers when designing a product for AM?12. How would you like to see a DfAM tool help you when designing for AM?13. What format would you like such a tool to take? E.g. paper-based, stand-alone software, web-based software, embedded in CAD system? |
|--|

Table 15: Semi-structured interview questions

4.8 Description of Product and Discussion of Interview Content

4.8.1 Avionics Enclosure

The utilisation of AM technology, particularly the LS system, for a subsonic unmanned aerial vehicle (UAV) enclosure as shown in Figure 81 came from the challenges of high cost of tooling and limited time for design and development of the part. Furthermore, other important requirements were that the part should be light weight, waterproof, should withstand electromagnetic interference and should be able to be reused.

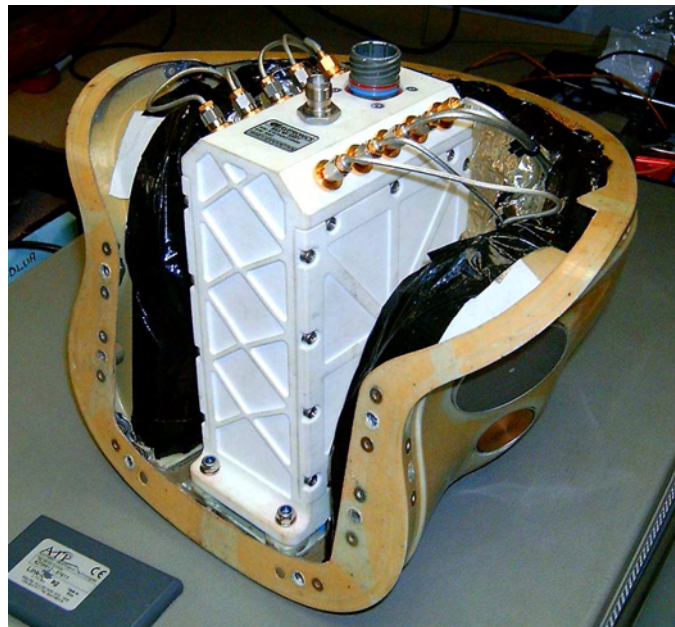

Figure 81: Enclosure on Subsonic UAV (in white)
(Du Plessi 2008)

The mechanical designer for the LS enclosure on the subsonic UAV had been involved in mechanical and electronic packaging design for 21 years. The installation of the electronic and electrical parts dictated the overall design of the part. The method used to design the part was to start from the outside geometrical shape and then to create the inside geometry of the part. Most of the design work was carried out with the aid of parametric CAD software. The process to design the part began with a design briefing which outlined the requirement and specification of the product. This consisted of descriptions of aspects such as the type of environment in

which the UAV would operate, the temperature resistance requirement and the vibration and stress to which the LS part would be subjected. The project designer then continued the discussion with the electronic and the system engineer to finalise the packaging design of the subcomponents into the finish part. There were various innovative design features that were incorporated in designing the enclosure and which were made feasible to produce when using an LS system. Figures 82 to 85 show some of these AM specific design features. They include the internal chassis and support to hold the electronic components, snap fit hooks to secure and fasten the components, mounting bosses and integrated cable supports.

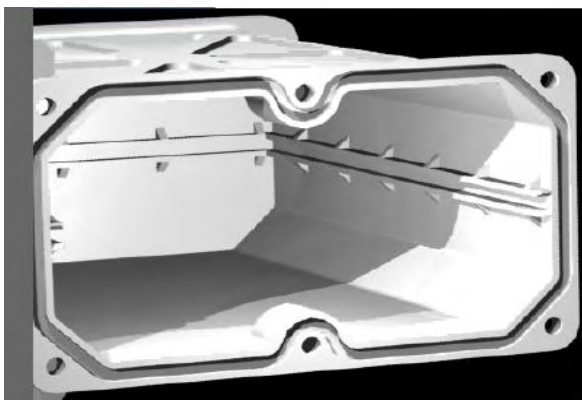

Figure 82: Internal chassis & support & external sleeve of enclosure (Du Plessi 2008)

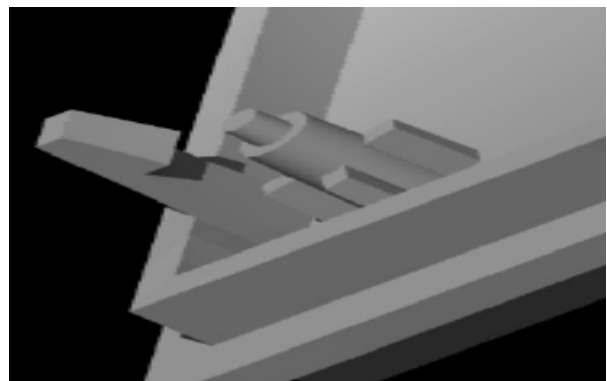

Figure 84: Mounting boss of enclosure (Du Plessi 2008)

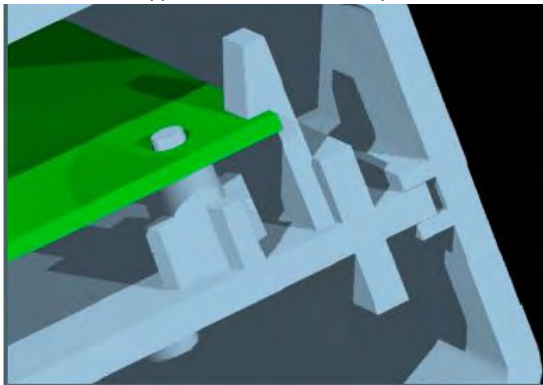

Figure 83: Snap fit hook of enclosure (Du Plessi 2008)

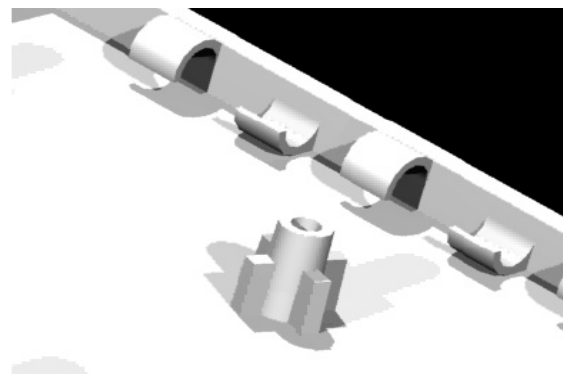

Figure 85: Integrated cable supports (Du Plessi 2008)

The main challenge the designer experienced was the lack of LS material specification to describe the stress and strain relationship and the fatigue resistance. Due to this, further analysis of material properties had to be performed after the part was built and this was expensive. Nevertheless, the use of LS to replace the

aluminium material used earlier also reduced the electromagnetic interference significantly and so the extra expenditure on testing was justified.

4.8.2 Automotive Active Ventilation System

The solar-powered device for vehicle ventilation produced by AM as shown in Figure 86 is an autonomous and self-supporting device, which is meant to be used when the vehicle is parked, especially during summer. The effect of installing the device is to maintain a lower temperature in the vehicle interior compared to the outside ambient temperature. Furthermore, the device has an indirect influence on reducing fuel consumption and hence the emission of pollutants since it results in less energy usage from the vehicle's air conditioning system.



Figure 86: Active Car Air Ventilation System
Source: <<http://www.najblog.com/avd/>> Accessed 20/7/11

The ventilation device was designed on the basis of being used in a specific vehicle model and it had to enable undisturbed opening and closing of the window. The most important advantage of the device was that it could be attached and unattached easily. Tests done showed that the device was capable of reducing the interior temperature significantly. For example on a sunny day with the ambient temperature over 30°C, the temperature inside the vehicle cabin can typically rise to over 70°C. With the device installed on a vehicle, the temperature was reduced to 40°C to 42°C, which is approximately 30°C lower.

The design process for the active ventilation device began with an analytical step of defining the initial variables with computational fluid dynamics (CFD) simulations. Firstly, the concept design of the device was made with parametric CAD software

that mounted the device virtually onto a 3D model of a vehicle. Then, a series of simulations utilising CFD and FEA were performed. The result enabled the definition of the size of ventilator, size of batteries, capacity and size of solar cells etc. The next step was designing the housing to embed all the components mentioned so that the device would achieve the desired functionality.

The 3D model of the window frame was provided by a car manufacturer, thus the housing of the device could be designed accurately to hold all the internal components including the seals and washers. Then, the post processing step of converting the CAD data to STL files was done and the part was made with an LS system. Finally, it was sandblasted and painted. Installation of all the internal components was made and it was assembled to the vehicle. Innovative AM design features that were incorporated within the ventilation device were a complex geometrical curving external shape, the internal structure of the product that was supported with an array of ribs and the top of the device that contained a small dome for the inlet of air for the ventilation process.

4.8.3 Medical Surgery Tools

The medical sector is one area in which AM has been much used in recent years (Truscott et al., 2007). Items such as implants that must be customised for each patient are now frequently recognised as candidates that are most economic to manufacture using AM technologies (Singare et al., 2009). Example of surgical equipment that has been developed for vertebral columns and fastening for ligaments that has been chosen for the case study is shown in Figure 87.



Figure 87: Medical equipment produced by laser sintering (Garcia 2008)

For producing a new range of medical assistance devices, the product specification and its features were provided by a team of medical practitioners. Examples of design requirements included making the device lighter and having new design features for surgical equipment. Some of the requirements resulted from patients' size variations. These requirements were then translated into a conceptual design and the final design of the surgical equipment was developed through collaboration between the medical practitioners and the designer. The 3D CAD model that was designed was then sent to be produced by metal laser sintering. Prior to building the part, the design had to be verified for its functionality and for the feasibility of being produced by AM. In addition, the assembly of the medical device with standard parts such as the hinges, nuts and bolts also had to be verified. This verification was undertaken by visualising the product using the CAD model

As can be seen in Figure 87, most of the medical devices were also customised with the customer's logo. Threads were built, both internal and external. The long part shown in the figure is hollow and the cross section of it is shown in the adjacent image. The whole set required 1.9 kg of stainless steel and took 70 LS machine hours to build.

Two of the most important factors to be considered with the medical assistance product were its geometrical accuracy and tolerances. AM related issues such as the surface finish also had to be dealt with. However, surface finish was considered as a secondary issue compared to the accuracy and tolerances, which were most pertinent. Another issue was the deformation of the parts which resulted from the parts' orientation during the AM build. Orientation, generally speaking, is a major issue to be considered during AM because it will affect both the build time and the mechanical properties of the parts produced. Furthermore, the internal stress of the parts was not able to be taken into account due to the current lack of tools to accomplish this. In addition to tolerance and accuracy requirements, important AM design issues for the medical equipment were to incorporate elements of ergonomics such as user safety, comfort and ease of use. Examples below describe how this was achieved:

- **Safety:** Design the device free from sharp edges that could harm the user.
- **Comfort:** The device was designed so that it was comfortable for the user for long hours of usage.
- **Ease of use:** This could be addressed by designing each device with specific functionality.

4.8.4 Customised Golf Club Grips

In recent years, the concept of mass customisation has been incorporated into product styling in order to meet diverse customer demands. Various applications of AM for customised product for user fit requirement in sports and medical can be referred in Chapter Three. In this study a relatively simple product was chosen to be the focus of the exercise, however, the principles that have been applied would be valid for more complex products.

At the Auckland University of Technology, the Department of Sport Science have undertaken some interesting work with athletes, studying ways of improving a golfer's performance. The department has collaborated with the Creative Industries Research Institute at the University to laser scan and AM customised golf club grips as shown in Figure 88. The idea of customising a golf club to fit exactly only one specific golfer's hand was envisaged due to the design and manufacturing advantages provided by AM. Every customised golf club grip has to be shaped according to the different shape and sizes of an individual's fingers and thumb thus, every grip produced has to be different and only AM is capable of producing it quickly and cost effectively. It is likely that such a design would contravene the rules of golf but it is a useful demonstration of the possibilities of AM enabled customisation.



Figure 88: Customised AM Golf Club Grip.
Source: Olaf Diegel, Auckland University of Technology, New Zealand.

The design procedure for the grips was as follows. Firstly, clay was wrapped around the handle of a standard golf club. Then the golfer gripped the clay and swung the golf club for 15 minutes. The clay was eventually moulded precisely to the golfer's hand size, position and contour. The design and manufacturing process then continued with laser scanning of the moulded clay. The laser scan data was then used to produce a 3D CAD model. Finally, an STL file of the finished CAD model was generated and a Stratasys FDM machine was used to produce the customised golf club grip. The overall design procedure was performed using the following process:

1. Discuss the golf club grip requirements through a semi-structured interview with the user.
2. Evaluate the original golf club grip design against pre-determined criteria such as grip comfort, aesthetics, usability, etc
3. Generate a user-fit design, recording ideas in verbal, sketch and written format from the sport expert.
4. Capture user-fit and other ergonomic requirements using modeling clay.
5. Scan and translate the data into a 3D CAD model.
6. Capture and verify aesthetic requirements using CAD rendering.
7. Verify functionality from the user.

Another issue faced within this project was the weakness between the layers built with the FDM system due to its vertical build direction. However, the designer was aware that an LS system would be much more appropriate for this application. This

case study has shown how the end users of products might become more directly involved in the design process, working in close proximity with designers to produce products that meet their individual requirements. This is a philosophy that is well suited to the capabilities of AM.

4.8.5 Automotive Dashboard Console

In recent years, parts consolidation has been incorporated into product design and development in order to ease the assembly process and for cost reduction. The focus of this case study was to redesign and manufacture an automotive central dashboard console as shown in Figure 89. The original injection-moulded console usually accommodates the vehicle's electrical control switches and audio entertainment system. The aim of this case study project was to provide a reduced number of parts and low volume production for a specially customised dashboard console in which the audio system was to be replaced with an electronic navigation system containing an LCD display.



Figure 89: Automotive Dashboard Console and Navigation Unit
(Burton, 2005)

According to the designer, this case study presented a number of design challenges. Firstly, there was no CAD data for the original console. Thus, he had to use reverse engineering (RE) techniques to capture the geometry from an existing dashboard console. The next design challenge was the complexity of the point cloud data that made it extremely difficult to create a suitable design for export to conventional CAD packages for editing. Rather than attempting to capture every single feature, the simplified top surface of the console was exported from RE and used as a base feature upon which other features could be parametrically re-modelled using conventional CAD software. This approach made the modelled features easy to alter. With a functional CAD model in place the objectives of the case study were as follows:

The new console must accommodate all of the standard electrical controls.

1. Secure packaging of the new electronic unit.
2. The user must be able to access the electronic unit's control systems, which were in the form of three push buttons and an infrared sensor.
3. The overall aesthetic appearance of the console was to remain the same or similar to the original console.
4. The design concept was to reflect the benefits afforded by AM.

During the project, a number of paper-based sketches were made and used to roughly visualise and evaluate features prior to CAD modeling. In addition, a digitising tablet and stylus were used to produce 2D presentation sketches. Secure mounting of the navigation unit was achieved in such a way as to provide ease of assembly, with the minimum number of components, whilst allowing simple non-destructive removal for replacement or repair. This was achieved with a "bounding box" that surrounded the unit and which served the dual function of locating the device and preventing any lateral movement as shown in Figure 90. A raised boss provided the unit with underside support and housed the screw fittings that were used to attach it to the console. The actual unit was to be controlled via infrared remote control and direct physical contact with the three push buttons on top of the unit. This was achieved through the incorporation of an AM-enabled integrated cantilever button as shown by the arrow in Figure 90.

The final AM console design, incorporating all of the features discussed, may be seen in Figure 91. Built using the LS process, the part is shown prior to the application of intended surface coatings and complete with all instrumentation controls and navigation unit in place.



Figure 90: AM enabled design feature (Burton, 2005)



Figure 91: Final design (Burton, 2005)

4.8.6 Summary of Findings (Preliminary Investigation Number Two)

Preliminary investigation number two presents an initial attempt at gathering, presenting and disseminating expert design knowledge required particularly for AM products. The aim of the study reported in this section was to examine how AM products are developed and to analyse the procedural design knowledge found so that they could be captured and reused in a manner that will assist other designers in designing for AM.

Through a series of semi-structured interviews with professional designers this research has attempted to gain insight into their thought processes when utilising AM. The study has identified specific AM enabled design features that the designers have been able to create within their case study products. Detailed observation of the products and parts reveals a number of features that are only possible with AM such as complex geometric forms, aesthetical features, variable wall thickness, hollow structure, undercut geometries, reduced number of parts, which was added into the product design.

Most of the designers interviewed made use of parametric CAD. A common design method associated with parametric CAD modelling, is to develop 3D models of parts using standard features such as extrusions, revolves and sweeps to create regular shapes that are easy to manufacture. This can be thought of as a geometrically constrained method of design thinking, and it is also promoted by conventional design for manufacture rules, which encourage simple shapes. However, when designing for AM, the method of design thinking can be the opposite, i.e. seeking out more freeform shapes and geometrical complexity that will yield the optimum design performance (functionally, ergonomically and aesthetically). The professional designers who design and developed the products in this study seem to have mastered this strategy. Most of the examples of products produced with AM in this study shows complex external and internal geometry that would be uneconomical to produce with conventional manufacturing systems.

Figure 92 shows the generic design process adopted by most of the designers. It is evident that a combination of AM and RE will enable the fast development of parts and products. Highly amorphous product forms such as the golf club grip may be digitised with RE technologies to produce CAD geometries that would otherwise be difficult to achieve using conventional software packages and strategies. However, the data obtained from 3D scanning has to undergo tedious post processing before it can be used. Furthermore, it is difficult to get smooth surface finishes directly from the laser scan data. Some sort of smoothing operation is required that can lead to a loss of shape definition.

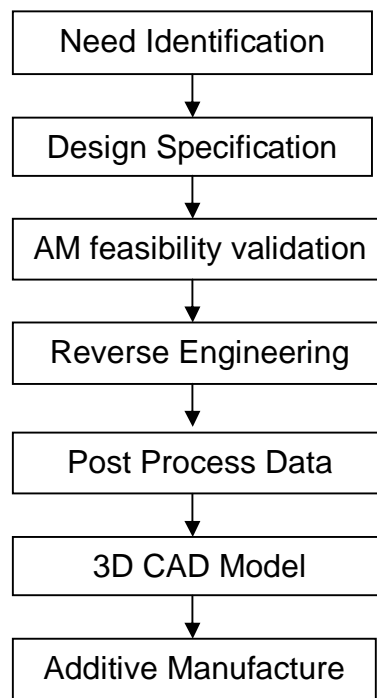

Figure 92: AM Design Process

Although this study addresses only a few case studies, by reflecting on the process of designing for certain AM products, it offers useful insight into the design procedures and knowledge needed to cope with the increasing capabilities that can be offered by AM. To further expand this knowledge, more examples of design for AM need to be studied. The knowledge generated from these could then be used to help build a first “rough-cut” version of the DfAM tool. Therefore, the next requirement for the research was to identify a wide range of AM design features and organise these into a usable format that will be described in the next chapter.

From the design point of view, one of the main challenges that can be associated with AM is the lack of a specific design aid tool and cumulative design knowledge to support design activity for AM. Most of the designers suggested that the DfAM tool should be integrated within a CAD system. There were also responses to have the DfAM tool embedded into a CAD system that could be accessed via the web for design collaboration. Rule based design was also suggested to have certain advantages in the design process for AM. In addition, given the highly visual nature of product designers, it was felt that the tool would be of most benefit to the design process if it included additional pictorial examples. Furthermore, a suggestion for a system to advise designers on the optimum AM product build orientation was also made.

4.8.7 Comparison of Preliminary Investigation Number One and Two

Both studies indicated that the students and the professional designers understood the advantages of AM compared to conventional manufacturing. The ability to produce small number of product, consolidate parts, customised and complex product design without additional cost were seen as the drivers for AM utilisation. Whilst the ability of AM to create practically any geometry provided the student designers with much freedom, it was noted that certain constraints still affected the design of AM products (refer section 4.2.5). One constraint felt by the student designers was the difficulties in translating desired design features into CAD geometry due to the increase in part complexity. This was due to the CAD capabilities of the students and their limited experience of practical AM product development. In addition, difficulties in constructing the internal structure of parts to accommodate other components such as circuit boards were also found. This was not an issue with the professional designers as most of them had good experience and skill in using CAD.

There were numerous suggestions given by the student designers concerning a tool or method that could be developed into a DfAM (refer section 4.2.7). Some of the suggestions given are beyond the scope of the research as they dealt more with AM process selection and material selection. However, most of the professional designers suggested that the DfAM tool should be integrated within a CAD system.

There were also responses to have the DfAM tool embedded into a CAD system that could be accessed via the web for design collaboration. Rule based design was also suggested to have certain advantages in the design process for AM. Some of these suggestions are beyond the scope of the research as they dealt more with development of product specific CAD tool.

In term of the product development, the student designers developed their product design for AM by understanding the requirements for the products and then referring to various source of visual information such as the internet and literatures. These were used to gather ideas and generate concept of the redesigned product and finally transform it into a CAD model. However, the professional designers who developed their product design for AM began with a design brief from the customers which outlined the requirement and specification of the product. This consisted of descriptions of aspects such as the type of environment in which the product would operate, the mechanical property requirements, the functionality and the ergonomics aspect of the product. The professional designers will then develop the product design to meets these requirements either by CAD modelling process or by reverse engineering method.

4.8.8 Implication for Future Research

From the design point of view, one of the main challenges that can be associated with AM is the lack of a specific design aid tool and cumulative design knowledge to support design activity for AM. Both studies also indicated the design issues and challenges that are faced by industrial designers when striving to design for AM. Although the studies in this chapter addresses only a few product design for AM, by reflecting on the process of designing the products, it offers useful insight into the design procedures and knowledge needed to cope with the increasing capabilities that can be offered by AM. To further expand this knowledge, more examples of design for AM need to be studied. The knowledge generated from these studies could then be used to help build a first prototype version of the DfAM tool.

The studies has shown that it may be possible to identify design features that are only possible or economical using AM and use them as an aid to disseminate the expert knowledge of AM experienced designers to other industrial designers. Given the highly visual nature of product designers, it was felt that the tool would be of most benefit to the design process if it included pictorial examples. Therefore, the next requirement for the research was to identify a wide range of AM design features and organise these into a usable format that will be described in the next chapter.

The studies has shown that the type of features incorporated into product designs will be influenced by the type of AM system being considered, the material to be used and various other factors. To provide a design support tool for all the available AM systems would be challenging and so the research will focus initially on LS parts or products. In addition, LS system enable products to be manufactured with various materials and have better surface and mechanical property compare to other AM systems.

Chapter Five – AM Taxonomy of Design Features

5.0 Introduction

Chapter five has shown some examples of design features that have been designed and developed by five professional designers to meet their needs and specification. A decision was made to explore the creation of AM enabled design features taxonomy as a method to aid in the development of the final design tool. This was because innovative design features were seen as an embodiment of designers' tacit knowledge about designing for AM. Organising these features into a systematic taxonomy was then a first step to making this knowledge accessible to other designers. This chapter will describe the evolution of these taxonomies.

5.1 Background

Over the last several years, AM has been an active area of research. The progress has been motivated by the perceived lack of suitable material properties, the long build times of AM systems, surface finish issues and limited AM system build envelopes. Research has been progressing to overcome all these issues. As research results have been published, it has become evident that various geometrically complex design features have been designed and developed, which are not possible to be manufactured with conventional methods of production such as injection moulding. However, the field lacks a commonly accepted description of AM design features. There is a need for a taxonomy to characterise the range of available AM design features. Accumulated information about AM enabled design features likely to provide very valuable knowledge for future product design for AM.

5.1.1 Introduction to Taxonomies

A French botanist De Candolle introduces the term taxonomy which has been derived from *taxis* (arrangement) and *nomos* (study) (Ostergaard K.J. 2009). Thus, taxonomy is a study of arrangements. Taxonomy is considered as a form of theory, a way of ordering complex phenomena in order to enable comparison (Shneiderman 1992). Researchers have used taxonomy for various functions including clarification of information such as the taxonomy of social purposes of public schools (Derr 1973), transmission of information such as an introduction to plant taxonomy (Jeffrey 1982) and for organising large bodies of information such as that generated when eliciting customer requirements (Morris and Stauffer 1994). In biology, taxonomy concerns the allocation of species to groups and subgroups on the basis of common ancestry (Wilson 1992).

In design research, taxonomies have also been applied to categorising mechanical design methods, tools and theories (Ullman 1992), decision support systems (Ullman 1995), idea generation methods (Shah 1998), collaborative design activity (Ostergaard K.J. 2009), design requirements from corporate customers (Gershenson 1999), design guidance for hypermedia design (Kemp and Buckner 1999) and defining a freeform feature classes (Nyirenda et al. 2005). For this research, a taxonomy can be considered as a classification of design features into subgroups based on their reasons of utilisation. This will enable the storage and retrieval of visual examples of feature information from a library to aid design for AM parts and products. Lough (2001) compiled and defined the requirements of a good taxonomy from various sources and these are listed in Table 16. The taxonomy generated in this research was developed to meet these requirements.

Requirement	Definition	References
Accepted	A taxonomy should be structured so that it can become generally approved	(Amoroso 1994), (Howard 1997)
Comprehensible	A taxonomy should be able to be understood by a user	(Ulf and Erland 1997)
Completeness	A taxonomy to be complete/exhaustive, it should include all possible categories	(Amoroso 1994), (Ulf and Erland 1997)
Determinism	The procedure of classifying the taxonomy should be clearly defined.	(Krsul 1998)
Mutually exclusive	The taxonomy should be mutually exclusive taxonomy will categorise each group into one category.	(Ulf and Erland 1997), (Howard 1997)
Terms well defined	The terms used in the taxonomy should be clear	(M.Bishop 1999)
Unambiguous	Each category of the taxonomy must be clearly defined so that there is no ambiguity.	(Ulf and Erland 1997), (Howard 1997)
Useful	The taxonomy should be useful to the intended user	(Ulf and Erland 1997), (Howard 1997)

Table 16: Requirements of a taxonomy
Adapted from: (Lough 2001)

5.1.2 Introduction to Design Features

Features have been defined by researchers in very broad contexts according to areas of application. However, the particular definition of a feature in design that is generally accepted is that a feature is a representation of a shape aspect of a product (Shah and Mäntylä 1995). According to Salomons et al. (1993), a feature is a set of information that refers to aspects of form or other attributes such as reasoning about the design, performance and manufacture or assembly issues of a part.

In design, form features can be grouped into two main groups: regular shaped and freeform features (Nyirenda et al. 2005). Regular-shaped features in spherical, prismatic or cylindrical forms are commonly used features in CAD modelling such as slots, holes, pockets and ribs. Freeform features may be grouped into freeform

volume features or freeform surface features (Pernot et al. 2008). Volume features are used to model solid parts whereas surface features are used to model sheet products.

Form features are intended to achieve a given function or to modify the appearance of a part (Salomons et al. 1993). Form features have also been classified according to the role they play in design. Cunningham and Dixon (1988) proposed a feature taxonomy based on static and kinetic features. Static features are structural in their functional intent and were divided into the following groups:

- i. primitive (major shape)
- ii. add-on (local modification)
- iii. intersections (interaction of primitive add-on)
- iv. whole form (attributes for entire part)
- v. macros (combinations of primitives)

Kinetic features are defined as entities that include energy or motion transfer (Cunningham 1988). Pratt (1988) presented a taxonomy of solid model features that could be incorporated into a solid modeling system. The taxonomy has been grouped into implicit and explicit features as shown in Figure 93. This taxonomy is considered important to this research because it provides an idea to classify the AM design feature into external and internal features (will be described in the next section).

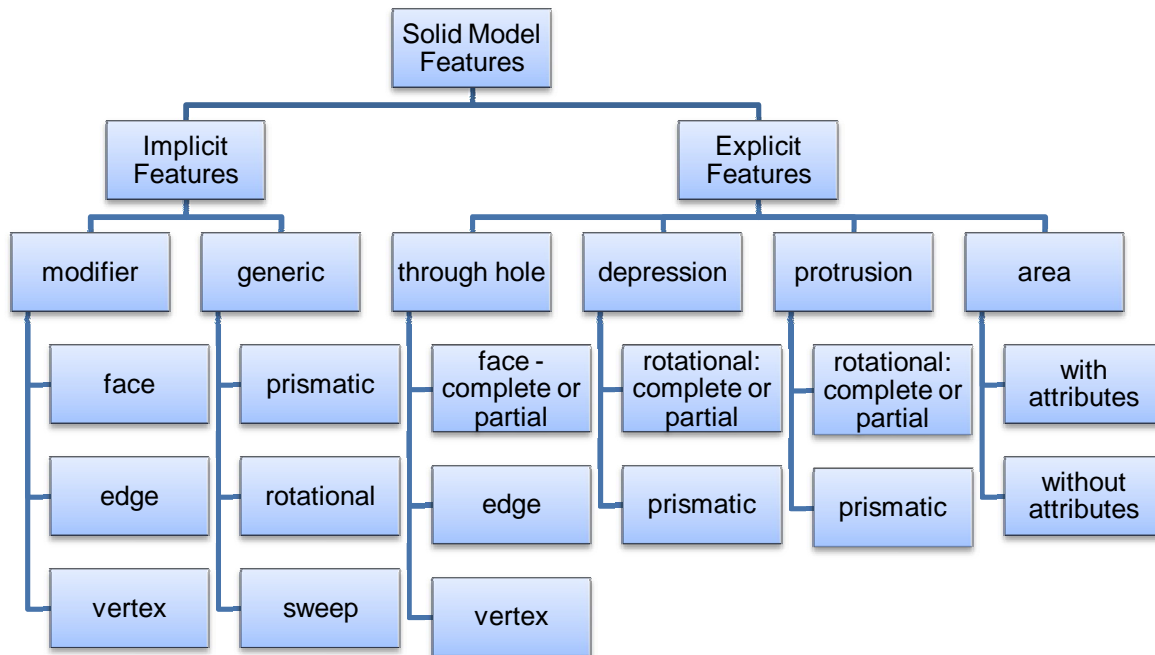

Figure 93: A taxonomy of solid models features (Pratt 1988)

Features are widely used for product modelling and play a very important role in CAD/CAM where they include design and manufacturing information. Design by features or feature based modelling is one of the techniques used in product design that enables the designer to create a product model by using features from a library (Nyirenda and Bronsvort 2009). The technique offers a set of editing operations such as attaching, inserting, deleting, placing and changing dimension of a feature into a model. In this technique features are incorporated in the part model from the beginning of the modelling process.

Fontana (1999) proposed a taxonomy for an aesthetic and functional characterisation by analysing various classes of free form features that can be recognised over a complex shaped product (Figure 94). This work has been a preliminary activity to aid the development of a modelling tool and to specify features usable for creating complex shapes.

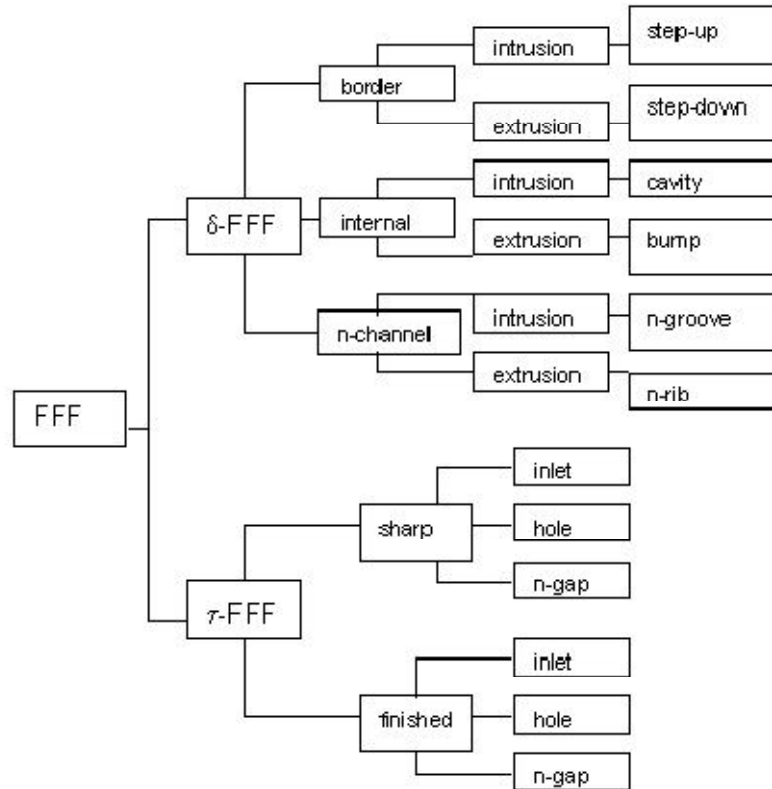

Figure 94: Free form feature taxonomy
(Fontana M. 1999)

Nyirenda et al. (2005) present a generic taxonomy which classifies freeform features based on shape characteristics and to their relative topology (internal, border or channel) in the feature model (Figure 95). In this taxonomy, freeform features are categorised into deform, cut, transition and compound. Deform features are protrusions representing material displacement in the model. A cut feature represents material removed from the model such as a hole. Transition features represent connecting features and may have an additive or a subtractive nature such as a blend. A compound feature is a combination of any of the basic features (i.e. deform, cut or transition).

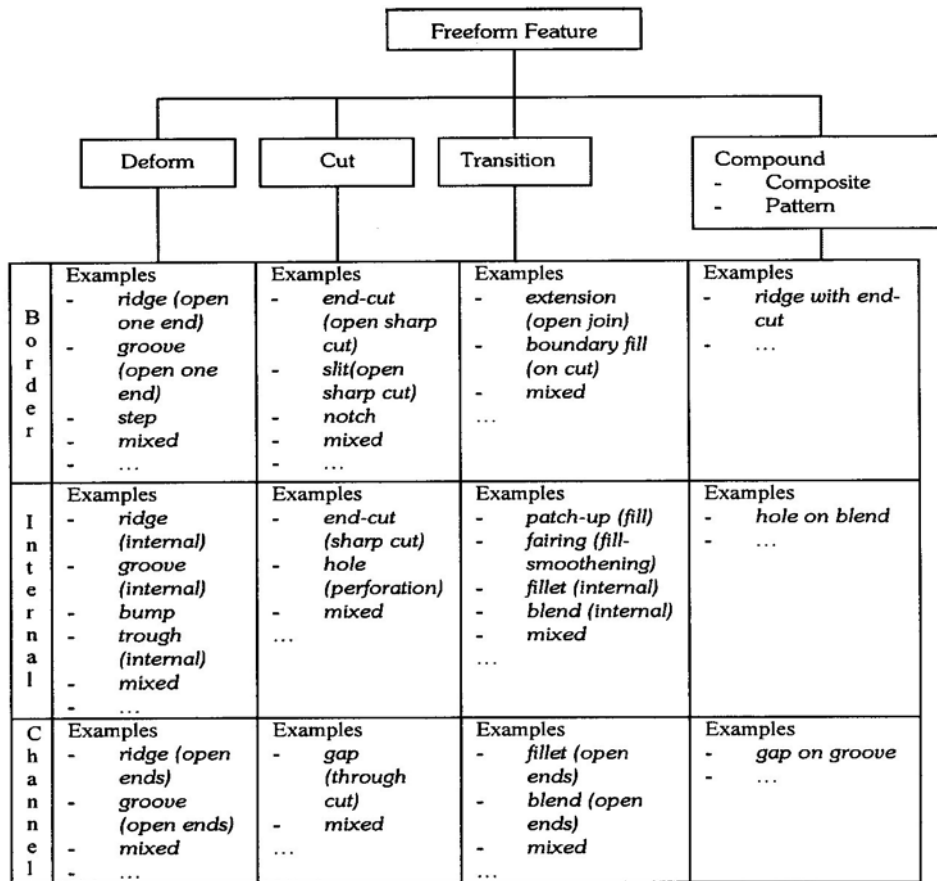

Figure 95: A Generic Freeform Feature Taxonomy (Nyirenda et al. 2005)

For this research, the AM enabled design features was defined as a features that would be uneconomical or very expensive to be produced with conventional methods. The literature review on the different types of the feature taxonomies above has given some thought on how to develop possible AM design features for this research.

5.2 Development of the AM design feature taxonomy

Taxonomy is normally developed by analysing various sources of literature and various domains and then grouping similar information until all the sub groups are included in a particular group. However, there was not much published material to support and form a comprehensive and organised AM design feature taxonomy. Several iterations of the AM design feature taxonomy were proposed before a satisfactory classification was achieved. The final taxonomy was developed by refining and combination of several iterations.

To aid with the development of the taxonomy, various examples of design features that were only possible to be AM were collected. A total of 106 design features were collected progressively and these features were used as the basis of generating an ordered classification. Table 17 provides a description of the five versions of the taxonomy. The taxonomy was developed to assist the development of the design support tool.

Figure	Description
Figure 96	Taxonomy of Internal and External AM Design Features
Figure 97	Taxonomy of Functionality and Form of AM design features
Figure 98	AM application design features
Figure 99	AM design feature taxonomy of functionality & complex geometrical features
Figure 100	AM reasons of application design feature taxonomy

Table 17: Description of five versions of the AM design features taxonomy

Figure 96 shows the first iteration of the taxonomy where the AM features have been classified into internal and external design features. As AM supports freedom of design, this taxonomy was developed to group the design features by external and internal geometries. The external features tended to relate to visual appearance whereas the internal features often related to function. The second level of the taxons shows some of the examples of features grouped under the external and the internal categories. The images that describe these features can be seen in Appendix B to E. The definition of these features can be referred to Appendix F.

Figure 97 shows the second iteration of the taxonomy where the AM design features were grouped under functionality and form features. The justification behind this development of the taxonomy was that AM could be used to improve product functionality and also to manufacture complex forms. Therefore, the design features that had been collected were grouped under these two taxons. However, these two rather simple taxonomies did not offer enough differentiation between feature types.

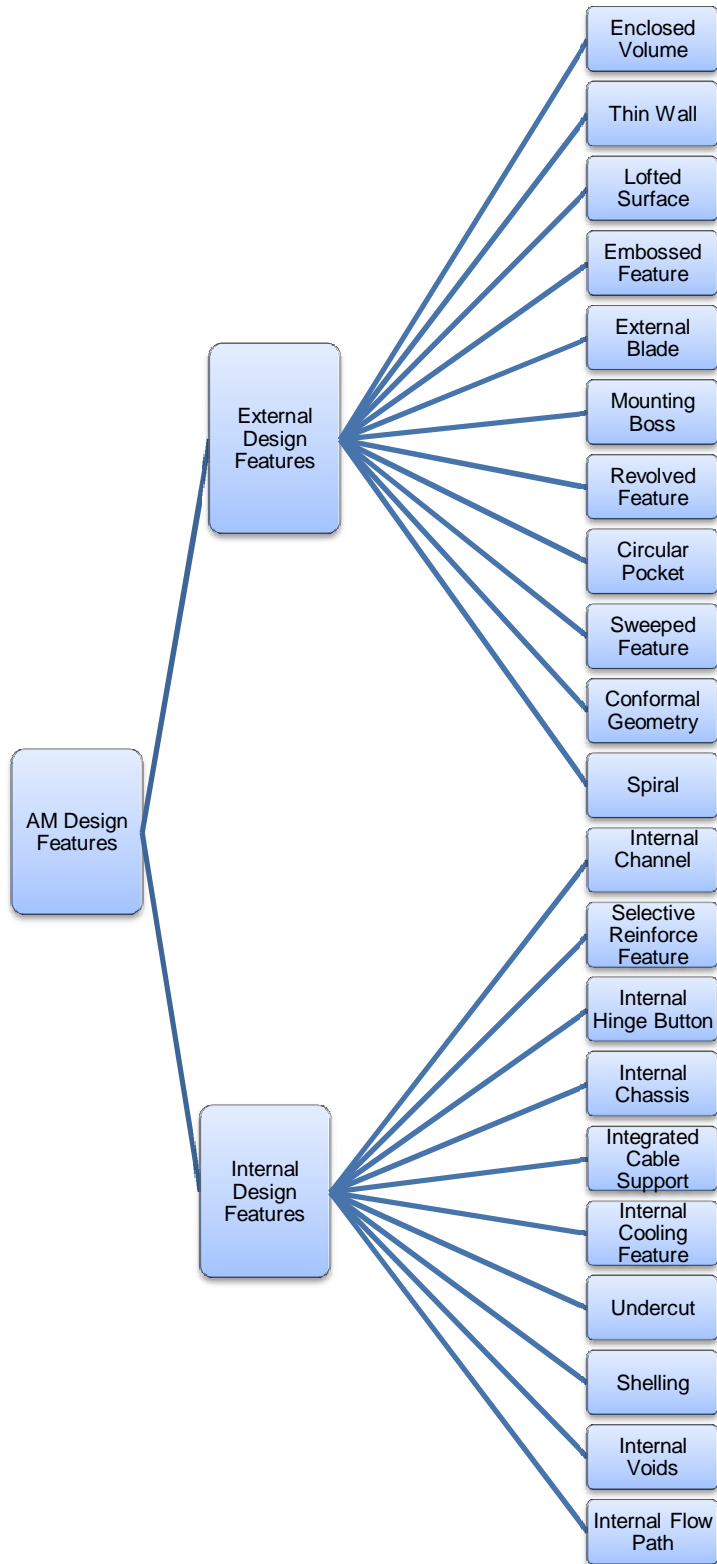

Figure 96: Taxonomy of Internal and External AM Design Features

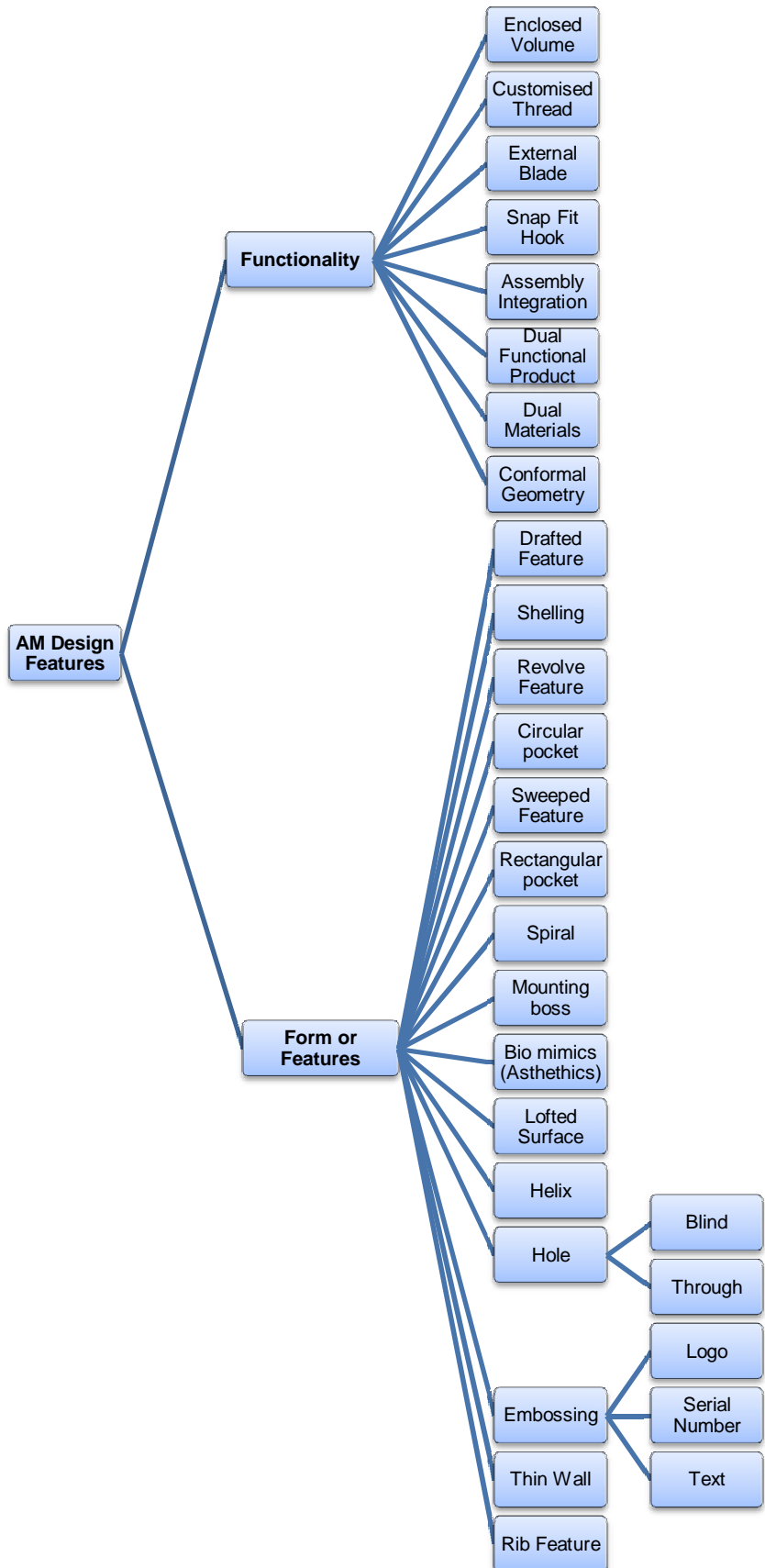

Figure 97: Taxonomy of Functionality and Form AM design features

Another approach was then followed in an attempt to create greater differentiation between features. One of the methods of providing an aid to the design of part or a product is by giving designers visual examples of existing AM design features used in different application areas. Figure 98 shows the third version of the taxonomy where the design features were grouped according to their areas of application. The application areas were medical, sport, consumer products, automotive, military and marine, aerospace, motorsport and fabrics. These areas of applications were grouped under customised features, consolidated features and complex geometrical features. However, this taxonomy also did not offer enough differentiation between feature types due to firstly there could be other areas of application that has not been specify and secondly some features under medical, sport and consumer product can be grouped under the complex geometrical features.

Figure 99 shows another version of the AM design feature taxonomy with functionality and complex geometrical features. As one of the advantages of AM that enable the manufacture of complex geometrical features and to enable certain functionality, this taxanomy has been developed. Under the functionality taxons, the design features that were collected were grouped under eight different sub categories namely fastening or holding features, weight reduction features, embossed features, size variations features, personalised parts or product, consolidated parts, dual functionality product and dual material product. Under the complex geometry taxons, the design features were grouped under instant assembly, internal structuring, shape optimisation and profile features. The third level of the taxons shows the examples of features. The images that describe these features can be seen in Appendix B to E. The definition of these features can be referred to Appendix F. However, this taxonomy also did not offer enough differentiation between feature types due to some features under functionality taxons can also be grouped under the complex geometrical taxons.

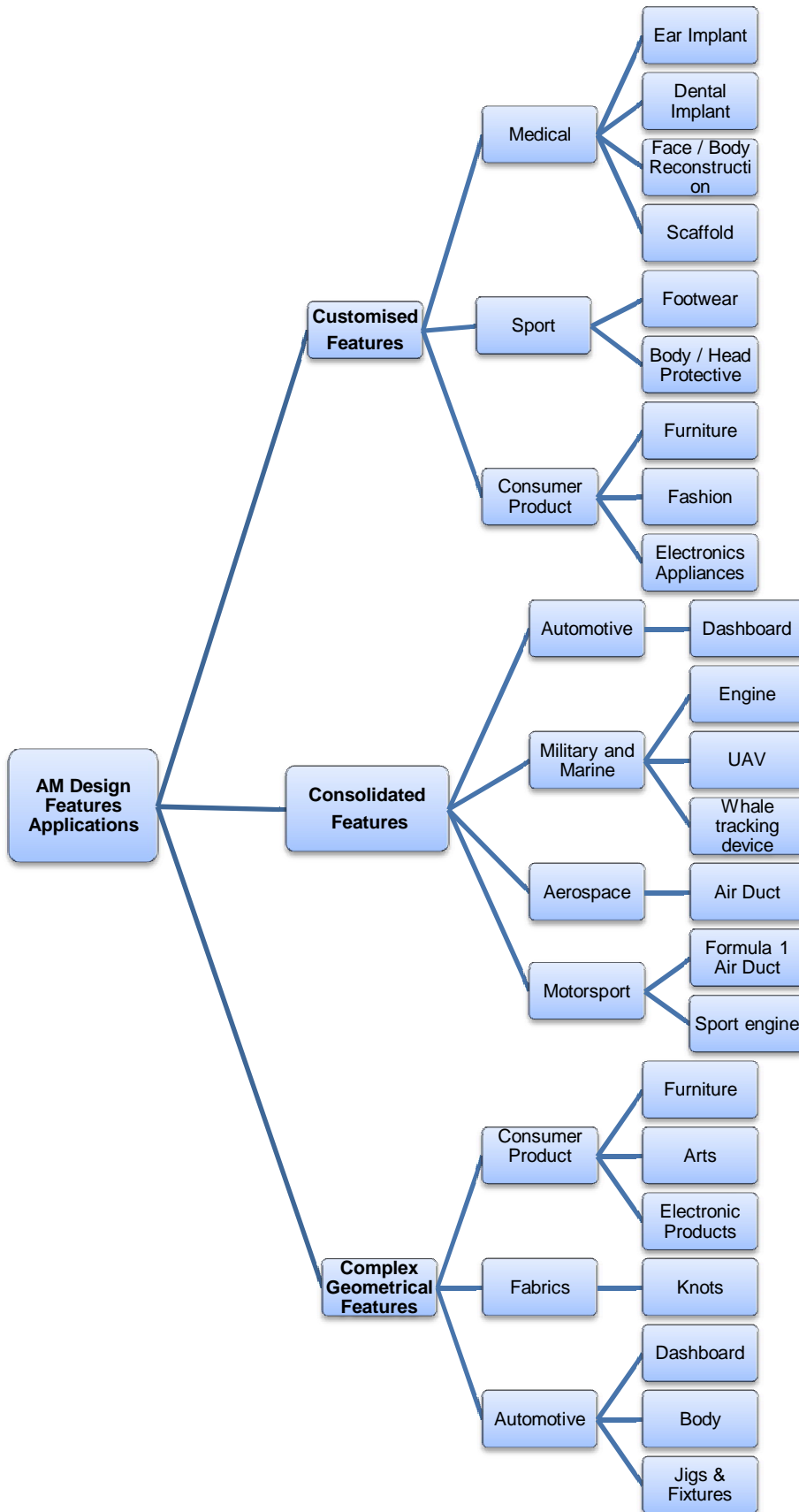

Figure 98: AM application design features

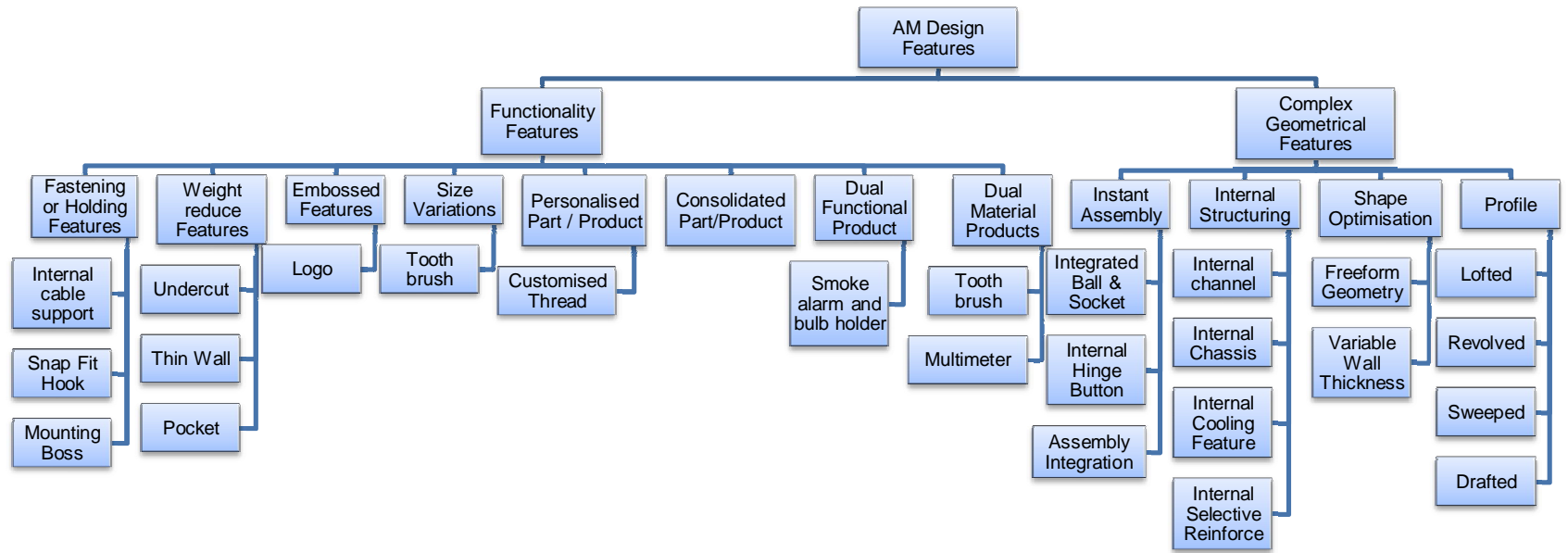

Figure 99: Taxonomy of AM functionality & complex geometrical features

Following the pilot study described in Chapter Four, it was noticed that one of the most important issues related to designing for AM was the reasons for utilisation of the technology. Designers need to understand the advantages and limitations of AM and the reasons for its utilisation prior to designing and producing parts or products with AM systems. Figure 100 shows the next iteration of the design feature taxonomy based on reasons for AM utilisation. It shows five reasons for AM utilisation. The reasons are user fit requirement, improved functionality requirement, parts consolidation requirement, aesthetics or form requirement and dual material requirement. There are fifteen sub categories of applications that were further expanded from the five reasons of AM utilisation. Under the user fit requirement there are design features that was grouped under sport, medical and consumer product. There are five categories of applications under the improved functionality requirement which consist of combine functionality features, weight reduction features, internal structuring features, multiple versions features and surface features. There are two categories of applications under the parts consolidation requirement which consist of fasteners removal features and instant assembly features. There are three categories of applications under the aesthetics or form requirement which consist of profile, surface and embossed features. There are two categories of applications under the dual material requirement which consist of over moulding features and integrated damping features.

Figure 101 shows a second version of the design feature taxonomy based on reasons for AM utilisation that consist sixteen sub categories of applications. The customised form was added under the aesthetics or form requirement. In addition, more design features were added into each of the sixteen sub categories of applications. Figure 102 shows the simplified version of the final taxonomy that consisted of four reasons for AM utilisation and its thirteen sub categories of applications. The dual material requirement has been grouped under the parts consolidation requirement as it is also a method of consolidation. All the features grouped within the thirteen sub categories are listed and described in the next section.

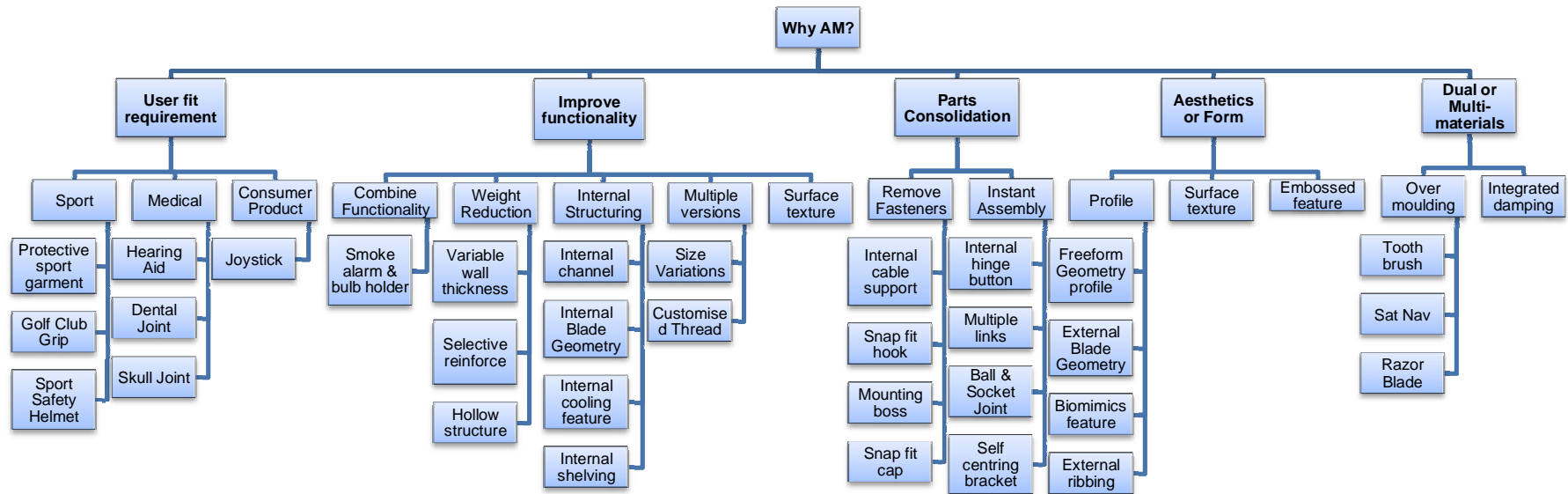

Figure 100: AM reasons for utilisation design feature taxonomy version 1

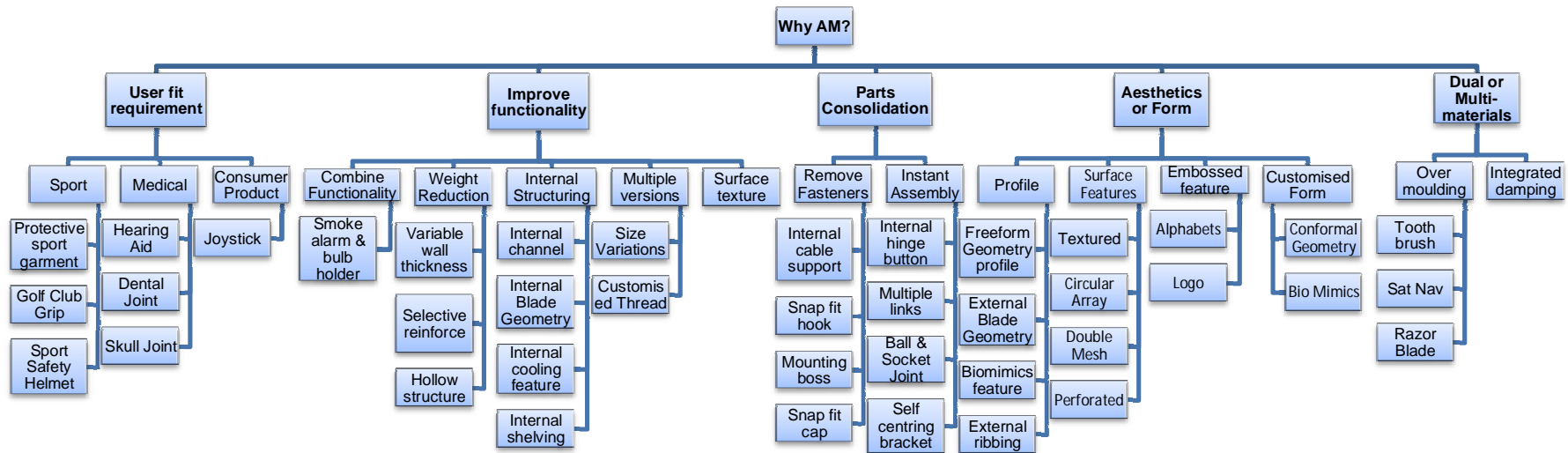

Figure 101: AM reasons for utilisation design feature taxonomy version 2

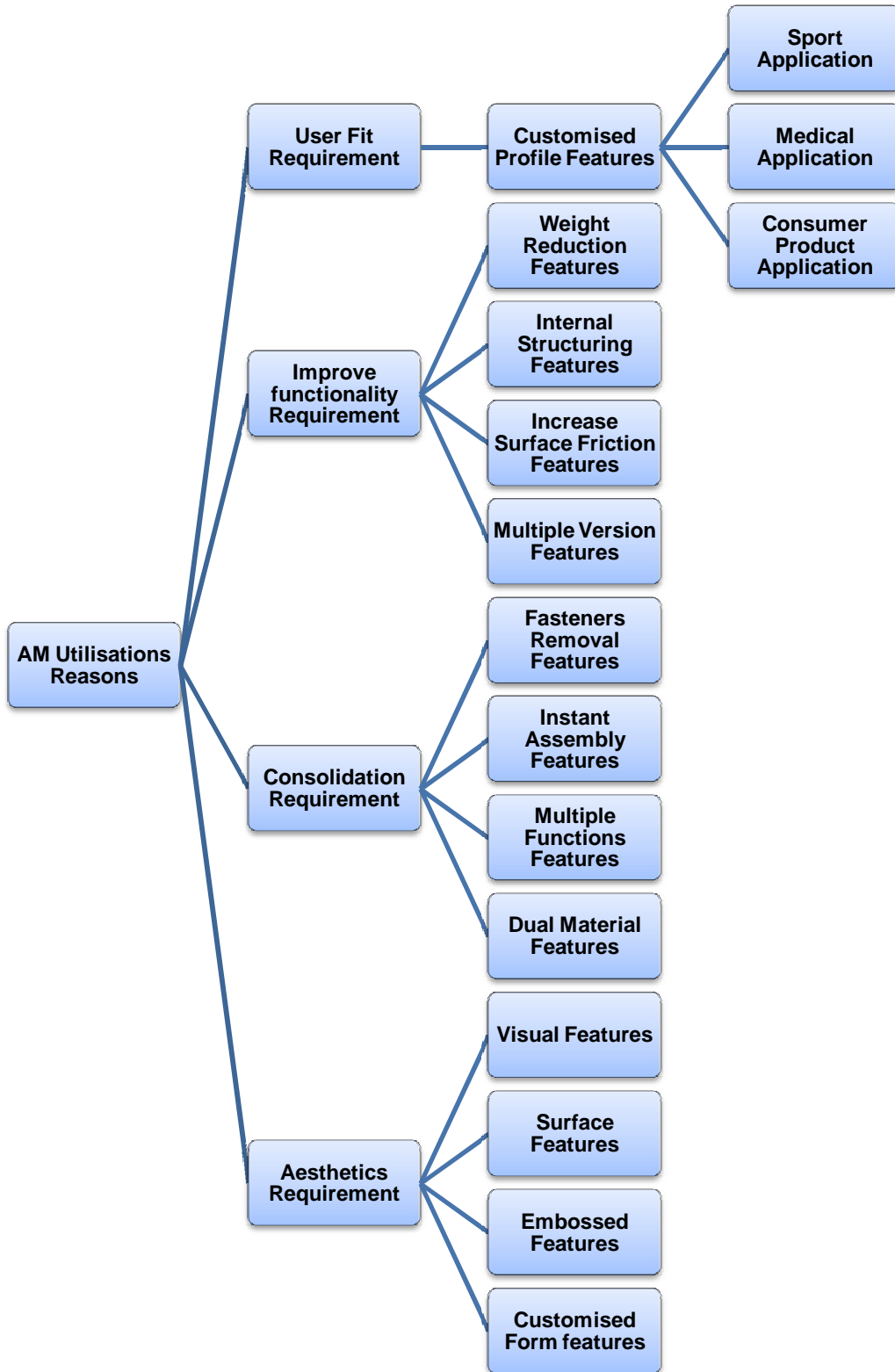

Figure 102: AM design feature taxonomy version 3 (simplified layout)

The final version of the taxonomy as shown in Figure 102 categorises various AM enabled features under four reasons of AM utilisation, namely user fit requirement, product functionality improvement, consolidation requirement, and aesthetic and form requirements. These are described below:

- ✓ User fit requirements can be defined as when parts or products have been customised to accommodate user requirements through the application of customised profile AM enabled features. From the perspective of AM, the user fit requirements were applied in three application areas namely sport, medical and consumer products.
- ✓ Product functionality improvement can be defined as methods that are used to improve part or product functionality using AM enabled features. The design features collected and grouped under this category are features that could be added into a product design to improve part or product functionality using AM. The product functionality improvement came from four approaches, i.e. weight reduction, increased surface friction, internal structure and multiple product versions.
- ✓ Consolidation requirements can be defined as the combination of parts, their functions or materials making use of AM. The design features collected and grouped under this category are features that could be added into a product design to combine various parts, to combine or have several functions or to combine its material from the perspective of AM. The consolidation can come from four approaches, i.e. instant assembly features, fasteners removal features, multiple functional parts and dual material features.
- ✓ The aesthetic and form requirements can be defined as methods that could be applied to improve product appearance. The design features collected and grouped under this category are features that could be added into a product design to improve product appearance from the perspective of AM. It includes approaches such as embossed features, surface features, visual features and customised form. More details about the types of features contained in the thirteen sub-categories that form the second level taxons are given in the following sections.

5.2.1 User Fit Requirement

The types of design features that were grouped under the three user-fit application areas, (namely sport, medical and consumer products) are shown in Table 18. The images that describe these features can be seen in Appendix B. The definition of these features can be referred to Appendix F. In some cases there are features that appear to be applicable to more than one category. In this case, the author has to decide the appropriateness of the application group that the feature has to be included and verify this with the authors' supervisor.

AM Reasons of Utilisation	Application	Design Features
User Fit Requirement	Sport	Body Contour
		Air Ventilation
		Boot Studs
		Hand Grip Contour (1 examples)
	Medical	Ear Canal Contour
		Tooth Contour
		Convex Concave Skull Contour
		Jaw Contour
		Limb Contour
		Knee Contour
		Bone Contour
		Spinal Contour
	Leg Contour	
	Consumer Product	Hand Grip Contour (2 examples)
		Wrist Contour (2 examples)
Body Contour (3 examples)		

Table 18: User Fit Requirement Design Features

5.2.2 Improve Functionality Requirement

As shown in Table 19, the improve functionality requirement were further expanded to include weight reduction feature, increase surface friction features and multiple version features. It list all the design features for each of these expanded categories of applications. The images that describe these features can be referred to Appendix C. The definition of these features can be referred to Appendix F.

AM Reasons of Utilisation	Application	Design Features
Improve functionality	Weight Reduction Features	Undercut
		Thin Wall
		Variable Wall Thickness
		Selective Internal Reinforcement
		Hollow Structure
		Honey-comb Structure
		External Ribbing
	Increase surface friction features	Textured Surface
		Circular Array
		Honey Comb Structure
	Internal Structuring Features	Internal Cable Route
		Internal Flow Path
		Internal Blade Geometry
		Internal Cooling
		Internal Shelving (avionic enclosure)
Internal Shelving (fuel Injector)		
Internal Cable Support		
Multiple Version Features	Encapsulated Spring	
	Customised Thread	
		Size Variation

Table 19: Improve Functionality Design Features

5.2.3 Consolidation Requirement

As shown in Table 20, the consolidation requirement was further expanded to include fasteners removal features, instant assembly features, multiple functional parts and dual material. The images that describe these features can be referred to Appendix D. The definition of these features can be referred to Appendix F.

AM Reasons of Utilisation	Application	Design Features
Consolidation	Fasteners Removal Features	Locking Groove
		Hook Clip
		Snap Fit Clip
		Slide Opening & Closing
		Snap Fit Hook
		Mounting Boss
	Instant Assemblies Features	Multiple Link
		Living Hinge
		Foldable
		Torus
		Interconnected
		Encapsulated Spring Lock
		Encapsulated Track & Ball
		Slide Feature
		Circular Living Hinge
		Foldable Living Hinge
		Integrated Ball & Socket
		Internal Hinged Button
		Enclosed Volume
		Ready Assembled Gear
	Interwoven	
	Encapsulated Bearing	
	Ball & Socket	
	Self Centring	
	Interlock	
	Multiple Functional Parts	Tape Dispenser
		Smoke Alarm & Bulb Holder
		Whistle & Buckle
Dual Material	Over Moulding (Brush)	

		Over Moulding (Razor)
		Over Moulding (SatNav)
		Over Moulding (Damper)

Table 20: Consolidation Design Features

5.2.4 Aesthetics and Form Requirement

As shown in Table 21, the aesthetics and form requirement were further expanded to include embossed feature, surface features, visual feature and customised form. It list all the design features for each of these expanded categories of applications. The images that describe these features can be referred to Appendix E. The definition of these features can be referred to Appendix F.

AM Reasons of Utilisation	Application	Design Features
Aesthetics or Form Requirement	Embossed Features	Embossed Alphabets (Headphone)
		Embossed Alphabets (Car door Handle)
		Logo
	Surface Features	Double Mesh
		Weave
		Interlace
		Circular Array
		Fingerprint
		Alphabets Element
		Lattice
		Spike
		Perforated
		Replicated
		Overlapping
		Twelve-sided dodecahedron
	Alphabets Feature	
	Visual Features	Transparency / Translucency
		Net Shadow Effect
		Circular Shadow Effect
	Customised Form Features	Curve Element
Loop		
Organic Form		
Flames		
Growth patterns of trees		
		Floating Element

		Human Body Sculpture
		Wave
		Spiral
		Swept
		Free form Geometry
		Bio mimic
		Interwoven Form
		Gyroid
		Tree Root

Table 21: Aesthetics or Form Requirement Design Features

5.3 Validation of the Taxonomy

The final iteration of the taxonomy (Figure 102) that was based on four main reasons for AM utilisation had to be validated before implementation as a design aid tool. The taxonomy was classified into four taxons consisting:

- user fit requirements,
- improve functionality,
- consolidation
- aesthetics or form requirement

These were established as the top level categories and further expanded downwards into thirteen sub categories of applications. According to Gershenson (1999), there are four metrics that should be used to validate a taxonomy:

- a) orthogonality – ensures that there is no overlap between the taxons
- b) spanning – ensures the taxonomy covers as much as possible
- c) precision – ensures the taxonomy goes into sufficient detail
- d) usability – ensures that the taxonomy is usable

As for this research, the second level of the taxon i.e. the reasons for AM utilisation was based on the findings from earlier research by the author (Maidin S., 2009). This indirectly validated the second level of the taxon. The third level of the taxon that contains the thirteen sub categories of application was developed based on the

grouping of the 106 AM design features collected. Due to the level of knowledge and experience with regards to designing for AM, it was decided that the validation of the taxonomy with student designers would not be appropriate. Due to time constraints, level of expectation and interest of professional designers to a product specific CAD tool that could support their specific product design for AM, it was also found that the validation of the taxonomy with professional designers would also not be appropriate. Due to these justifications, the final taxonomy was validated firstly by the author and by the authors' supervisor who has extensive knowledge and experience in AM and product design. The validation of the taxonomy by the author was made through the four criteria suggested by Gershenson:

- To check the orthogonality, questions such as 'is there any overlap between the taxons' was considered?'
- To check spanning and precision, questions such as 'what is lacking in the taxonomy?' and 'are the subcategories appropriate was considered?'
- To check the precision, question such as 'what categories require more information was considered?'
- Finally, to check the usability, questions such as, 'is this taxonomy of value in describing AM design features was considered?'

In terms of orthogonality, each of the four taxons and its thirteen sub categories were clearly distinguished to ensure it was not repeated in other groups. In terms of spanning, to ensure the taxonomy covers as much as possible, relevant literature and websites that provide examples of AM enabled design features were surveyed. It was found that little work has been done to provide an inclusive and collective source of reference for AM enabled design features used by designers. As AM systems improve, more categories could be added in future to form a better and comprehensive taxonomy.

In terms of precision, to ensure the taxonomy goes into sufficient detail, 106 AM enabled design features were collected from relevant literatures and websites to form the taxonomy. While it is hard to prove that a taxonomy is complete or exhaustive, it can be justified through successful categorisation (Hansman and Hunt 2005). Finally, usability was checked by questioning whether the structure could be

well understood and if its description was clear and concise. This was further achieved by ensuring a clear and structured layout with the addition of visual examples to aid explanation in a form of a database (Chapter Seven, Section 7.3) and by validating the database that will be described in Chapter Eight.

5.4 Summary

This chapter explores the development of the AM taxonomy by identifying and organising AM enabled design features for easy retrieval and assistance for design for AM and as a method to aid in the development of the final design tool. The final taxonomy comprises four reasons of AM utilisation namely user fit requirements, product functionality improvement, parts consolidation, aesthetic and form requirements. These four groups formed the top level of the proposed taxonomy and were further expanded to include thirteen sub categories of applications in the second level of taxons. The taxonomy has categorised 106 AM enabled design features under these thirteen sub categories namely sport, medical, consumer product under the customised profiles features of user fit requirement. Other sub categories were weight reduction, increase surface friction, internal structural, multiple version, instant assembly , fasteners removal, multiple functional parts, dual material, embossed features , surface features, visual features and customised form features. The advantage of the reason for AM utilisation feature taxonomy is the structured way in which it can be used to classify AM enabled design features. In structuring and validating the taxonomy, four matrices encompassing orthogonality, spanning, precision and usability were adopted. The next stage is the implementation and evaluation of a prototype software as a design support tool for AM and this will be described in the next chapter.

Chapter Six – Implementation of the Design for Additive Manufacturing (DfAM) Feature Database

6.0 Chapter Overview

Chapter six described the iterations of several taxonomies that were developed as a method to explore the structure of the final design aid tool. Having established the final iteration of the taxonomy that was based on the reasons for AM utilisation and to fully benefit from the advantages afforded by AM, it was then proposed that an appropriate design aid tool be implemented.

AM is no longer just a quick way of making models, but rather a manufacturing approach that can be used either directly or indirectly (through secondary processes) to produce finished parts. The most effective way of achieving this is to give designers a methodological approach for designing for AM. Following a discussion with Prof. Uli Holtzbaaur (reference to a personal communication) a knowledge-based engineering professor from Germany, a decision was made to apply a “software rapid prototyping” approach to develop the design aid tool for AM. The starting point for this was the categorisation of 106 AM design features that has been gathered and grouped into a taxonomy (see Chapter Five) that would form the basis of a design feature database. Therefore, it was decided that this research should identify a suitable Design for Additive Manufacturing (DfAM) ‘software prototype’ tool that will assist industrial designers in identifying the feasibility of AM for a given part or product and also in assisting the generation of product design for AM, based on reasons for AM utilisation.

Most design aid tools available currently support design at the preliminary stage, such as quality function deployment, or at a later stage of design, such as detail design, with various CAD tools. Strategic approaches that support early stages of design for conventional manufacturing such as design for manufacture and assembly (DFM and DFA) are also available and useful. However, currently there is no design aid tool for the AM parts or products. Previous work, undertaken by Burton (2005), went as far as suggesting the format and structure for a tool but this was never

developed into a fully working system. Burton's proposed tool was a paper-based system that consisted of a series of questions used to determine the appropriateness of AM as a method of production. Linked to the questionnaire was a concept profiler that suggested applicable design features and an assessment matrix that was used to evaluate conceptual designs which was also done manually. The tool developed as part of this research took some of Burton's ideas, added new ideas, and implemented them within a database system containing AM design features as categorised in the taxonomy reported in Chapter Five.

Initially, using Visual Basic to implement the feature database was considered, with the intention to make the tool available online. However, due to the large amount of images in the database this would have made the system inefficient. Therefore, the decision was made to use the Microsoft Access database system due to its capability to facilitate the storage of large file sizes, data manipulation and retrieval of data and images to show the working principle of the tool. Furthermore, simple macro operations to automate tasks and simple visual basic programme scripts can also be implemented.

6.1 DfAM Features Database Objectives

To expose a designer to the concept of freedom of design that AM brings, the AM feature database aimed to provide visual examples of AM enabled features that could be imparted to a product design. The database was intended to provide visual inspiration to industrial designers about the innovative, creative and complex geometrical design features enabled by AM that could be applied to their product design. The database needed to provide examples of design features that could be used to obtain specific functionality with regards to AM capability. To best assist industrial designers for designing of part or product for AM, a number of criteria had been identified as being appropriate to the formulation of such a tool. These were as follows:

- i. Needs to be applicable to any given product or part
- ii. Needs to help ascertain the feasibility of AM
- iii. Should suggest appropriate design features to be added into a product design

The structure and content of the database were created with these objectives in mind. Industrial designers were the target users for the DfAM feature database, so the system was not necessarily aimed at highly computer-literate users and it should not require any special training or computer knowledge to successfully use it. Thus, the system and the user interface should be simple and intuitive. The number of inputs and operations should be minimised for speed and the simplicity of using the system. Finally, the results should be presented to the user in a clear and concise manner displaying only the most relevant information.

6.2 Proposed DfAM Process

Based on generic product design phases, Figure 103 shows the proposed DfAM process that begins with identification of a need. The details explanation on how the 'software prototype' operates will be explained in the following sections.

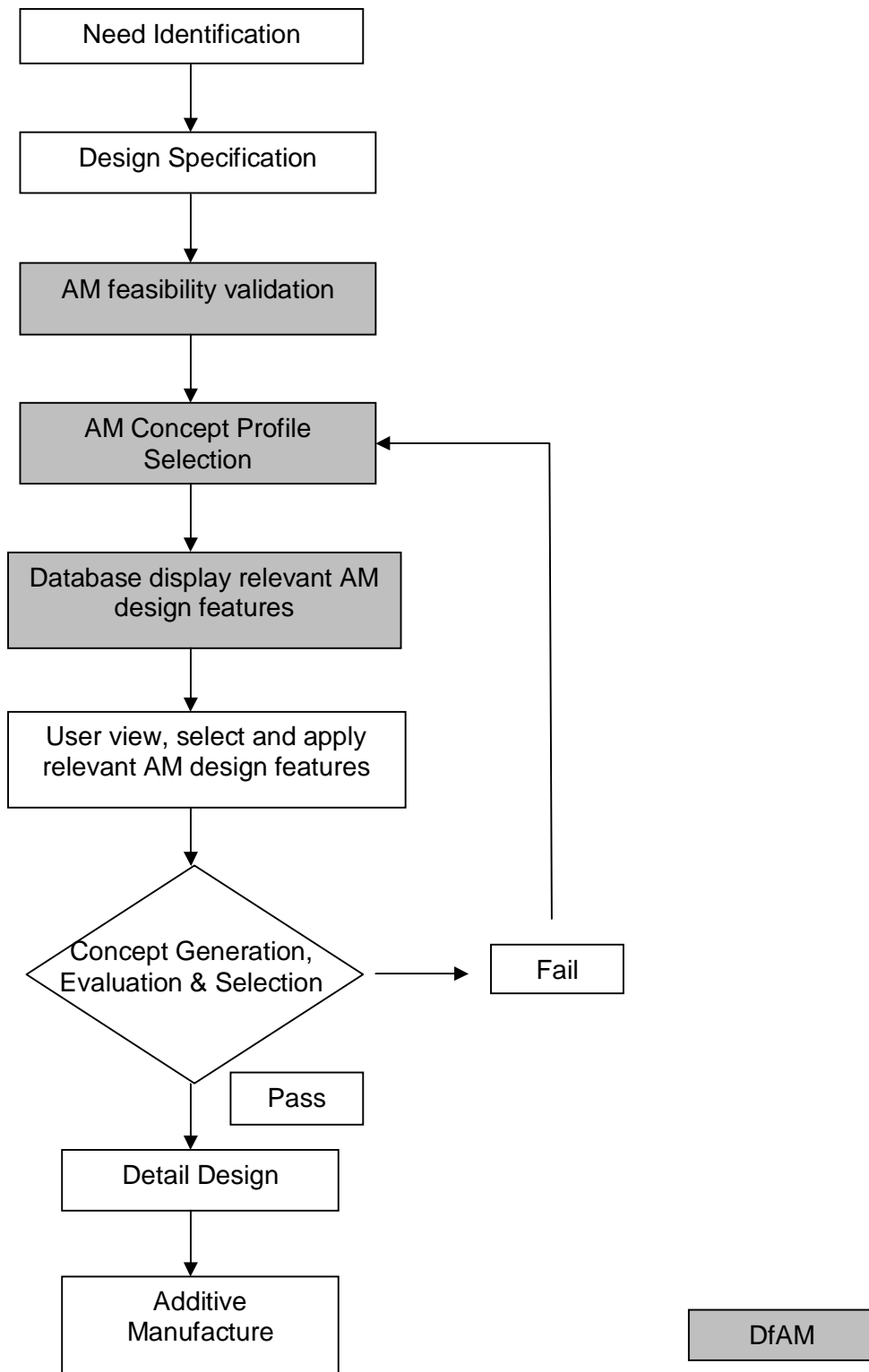

Figure 103: Proposed DfAM Process

After identification of a need, this is followed by generating the design specification. Having established necessary specification criteria, this is followed with validating the appropriateness of using AM for a given part or product. The next step is the “concept profile” selection process where users have to select appropriate profile options that suit their design need. Based on the options selected, the user would be shown various examples of design features that would be applicable within the design of their particular part or product. The designer will then select the appropriate and suitable features and adapt them to be applied to their product design. The shaded stages in Figure 103 show the DfAM processes.

6.3 DfAM feature database development

The development of the design for DfAM feature database was based on the taxonomy generated during the earlier stages of the research. Based on the four reasons for AM utilisation and findings from published literature and various websites, a total of 106 DfAM features (Table 22) were identified and clustered into thirteen sub-categories of applications. Table 22 also shows the number of features for each sub-category. For instance, for weight reduction seven design features have been collected. Most of these design features were designed for and manufactured with the laser sintering process. The design features taxonomy is by no means exhaustive and it is expected that it will be expanded by adding more design features in the various sub-categories, and perhaps more sub-categories also.

Reasons for AM	Application	Number of design features
User fit requirements	Customised Profiles Features	Sport = 4 design features, Medical = 9 design features & Consumer Product = 7 design features
Improve functionality	Weight Reduction	7 design features
	Increase surface friction	3 design features
	Internal structural	8 design features
	Multiple version	2 design features
Parts consolidation	Instant assembly	18 design features
	Fasteners removal	7 design features
	Multiple functional parts	3 design features
	Dual Material	4 design features
Aesthetics	Embossed features	3 design features
	Surface features	13 design features
	Visual features	3 design features
	Customised form features	15 design features
	Total	106 design features

Table 22: Number of design feature for a specific AM reasons and application

The structure of the taxonomy was implemented within a Microsoft Access database known as the DfAM design feature database. A “rapid prototyping” software approach was utilised where a “beta” version of the tool was developed to enable rapid user testing and improvement of the system. A series of Access forms were created to enable designers to search or browse through the feature categories. The design feature database enabled industrial designers to visualise and gather design feature information from examples in the database that could be incorporated into

their own design work. Figure 104 shows the welcome screen and Figure 105 shows the general information screen where the user is requested to provide details such as their name, the organisation, phone number, email address, the product or parts name and the AM system and material they intend to use.

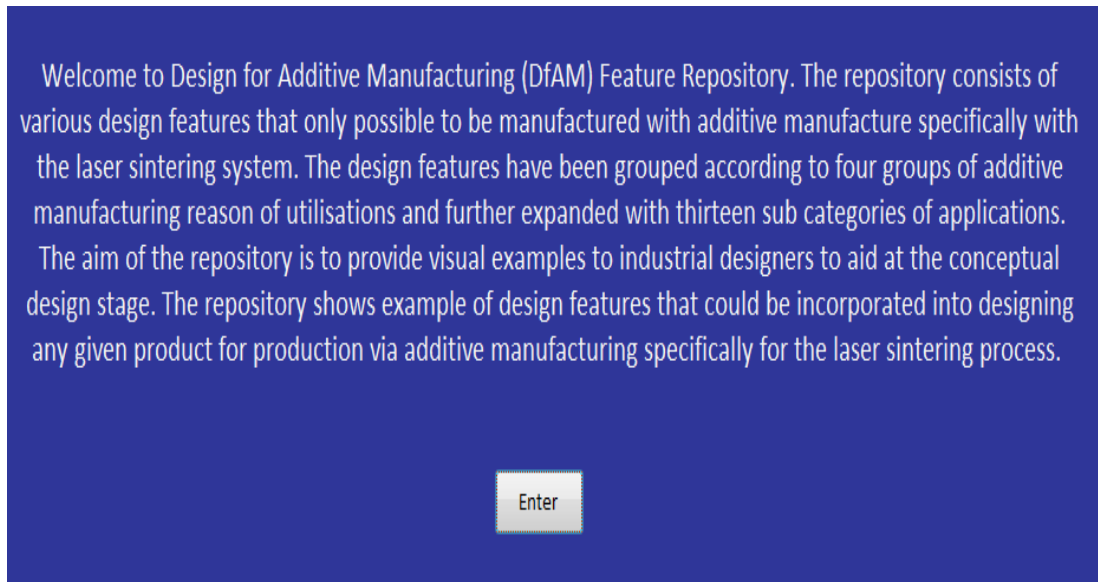

Figure 104 : Screen shot of the welcome page of the DfAM feature database

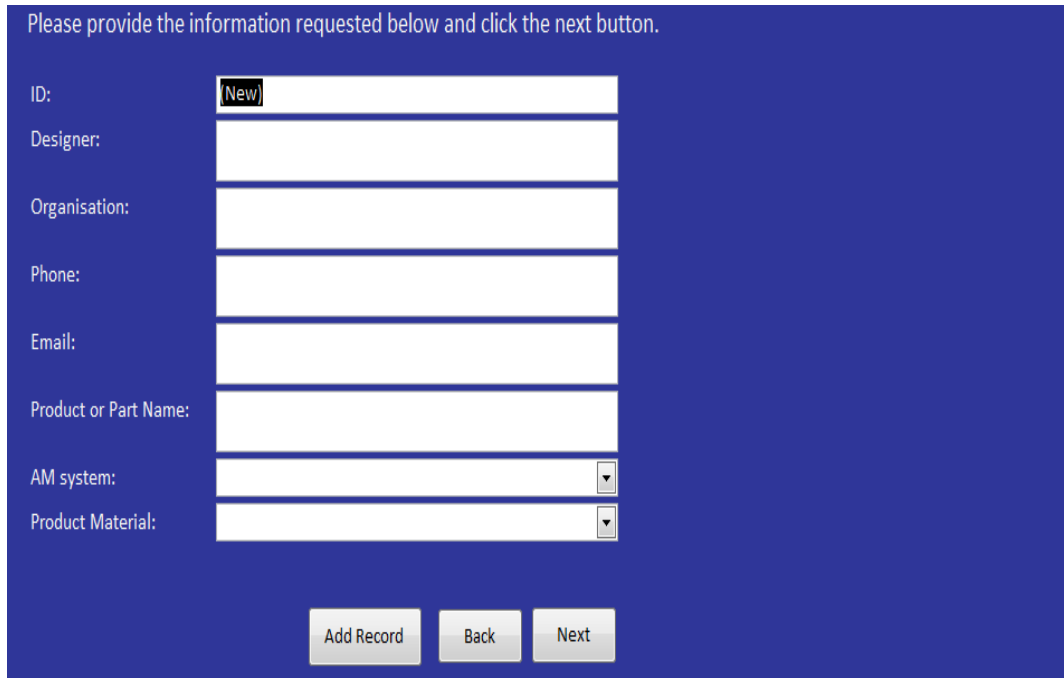

Figure 105: General Information Screen

Before a part or product design can proceed to the concept profile generation stage, it has to be evaluated to find the feasibility of manufacturing it with AM. As shown in

Figure 106 the database contains four simple AM feasibility evaluation questions. The first question is regarding the number of targeted production unit. If the given answer to this question is more than 10,000 units, then a message informing that AM is not suitable will appear (Figure 107). The 10,000 value is rather arbitrary but is trying to indicate that AM is generally unsuitable for high volume production. Otherwise the user may proceed to provide answers to the next three general questions, which evaluate the importance of overall surface finish, importance of consistent mechanical properties and the importance of tolerance and accuracy of the part or the product. These questions were developed based from the literature review in Chapter Three. As a summary, it was found that the number of targeted production unit, mechanical property, surface finish, tolerance and accuracy of a product or a part are some of the important factors should be considered for selecting AM as a manufacturing method.

Please provide the information below that best describe the feasibility of AM for your application and click the evaluate feasibility button.

1. What is the expected production volume?
 10's 100's 1000's 10,000's
2. How important is the overall surface finish?
 Very important Desirable Unimportant
3. How important is the consistent mechanical property?
 Very Important Desirable Unimportant
4. How important is the tolerance and accuracy?
 Very Important Desirable Unimportant

Figure 106: AM feasibility validation screen

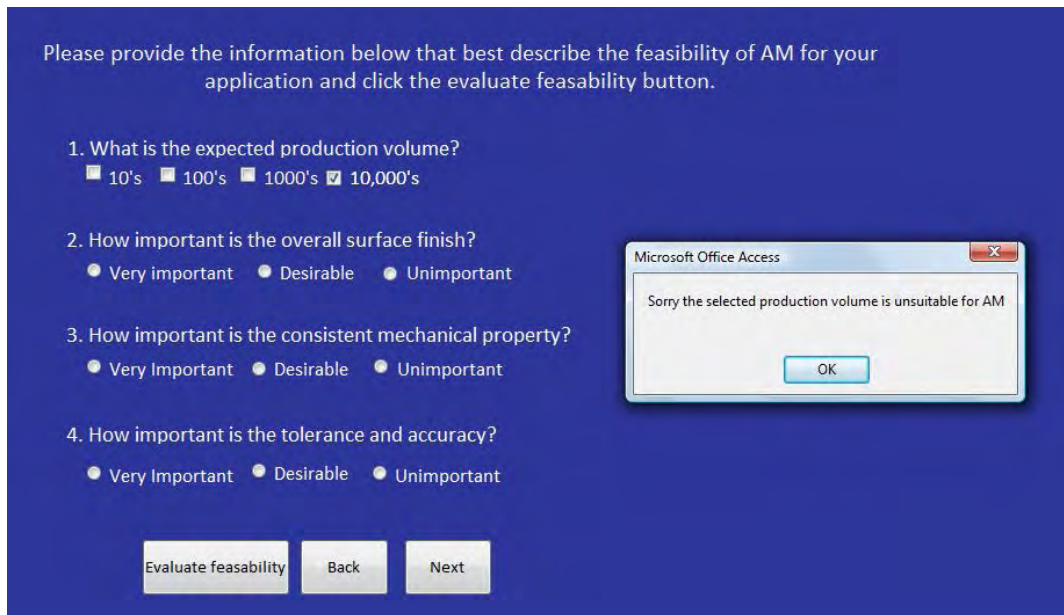

Figure 107: AM is not suitable for production volume more than 10, 000 units

For the questions about the overall surface finish, the consistent mechanical property and the importance of the tolerance and accuracy of a part or product, a weighting and rating technique is used to evaluate the suitability of AM. Table 23 shows the weights and ratings used for these criteria but this is likely to change as a result of future AM systems development. A “suitability score” for using AM can be determined through a simple algorithm and different messages presented to the user, depending on the score achieved. For example, if the total suitability score is less than one, then AM is deemed unsuitable for this particular application (Figure 108). If the total suitability score is greater than one, then AM is deemed suitable for this particular application. Suitability scores between these two values will result in a “potentially suitable” message (Figure 109). Again, these values are currently set at arbitrary levels but will be tailored after increased experience of using the system.

Criteria	Weight	Rating	Weighted score
Surface finish	25%		
Mechanical property	50%		
Accuracy and tolerance	25%		
Total weighted score			

Description	Rating
Very important	1
Desirable	2
Unimportant	3

Table 22: AM feasibility scoring matrix

Please provide the information below that best describe the feasibility of AM for your application and click the evaluate feasibility button.

1. What is the expected production volume?
 10's 100's 1000's 10,000's
2. How important is the overall surface finish?
 Very important Desirable Unimportant
3. How important is the consistent mechanical property?
 Very Important Desirable Unimportant
4. How important is the tolerance and accuracy?
 Very Important Desirable Unimportant

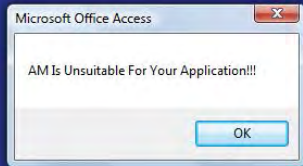

Figure 108: Message showing that AM is not suitable

Please provide the information below that best describe the feasibility of AM for your application and click the evaluate feasibility button.

1. What is the expected production volume?
 10's 100's 1000's 10,000's
2. How important is the overall surface finish?
 Very important Desirable Unimportant
3. How important is the consistent mechanical property?
 Very Important Desirable Unimportant
4. How important is the tolerance and accuracy?
 Very Important Desirable Unimportant

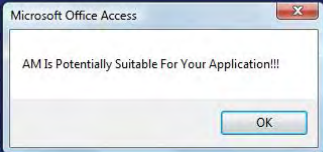

Figure 109 : Message showing that AM is potentially suitable

The next stage of the database is the concept profile generation screen as shown in Figure 110. There are 11 options that can be selected individually and the user responses dictate which categories of features are recommended subsequently. These questions were derived from the four reasons for AM utilisation and their sub categories of application as shown in Table 24. For example if a user were to select the first option (need custom fitting for individual user), and then click the generate concept profile button, the customised profile feature category and the customised form category would be enabled (Figure 111). This will assist the user in selecting the appropriate features to be applied in their concept design. Then the user has to explore and view the features that have been compiled in these categories. The user may then apply suitable feature found into their product design. An example of a feature under the customised form is shown in Figure 112.

Select one of the following option that best describe the requirement of your part or product and click the generate concept profile button. You may select any other options later.

Does the part or product:

- need custom fitting for individual user?
- need to be lightweight?
- subjected to hand held?
- have internal structures?
- benefit from having available in range of sizes?
- benefits from parts reduction?
- need to be attach or fasten to other component ?
- having other functions?
- require over moulding?
- need to be aesthetically pleasing?
- need to have creative and innovative form or geometry?



Back Generate Concept Profile

Figure 110: AM Concept Profile Generation Screen





Below are the four main reasons of AM utilisations and their sub categories of application. Click the enabled button to view the design features and click the back button to select other concept profile options.

1. User fit requirement - Product customised to accomodate user requirement





Customised Profile Features

- Sport 
- Medical 
- Consumer Product 





2. Product Functionality Improvement - To add value by improving product functionality

- Weight Reduction Features 
- Increase Surface Friction Features 
- Internal Structuring Features 
- Multiple Version Features 

3. Consolidation Requirement - To combine parts , its functions or its material

- Instant Assembly Features 
- Fasteners Removal Features 
- Multiple Functional Parts 
- Over Moulding 

4. Aesthetics or Form Requirement - To add value by improving product appearance

- Embossed Features 
- Surface Features 
- Visual Features 
- Customised Form 

Back Keyword Search Exit

Figure 111: Categories that have been enabled

Additive Manufacturing AIM:	Aesthetics Requirement	
Sub category:	Customised Form	
Design Features:	Curve Feature	
Application:	Light	
Functionality Keywords:	Aesthetics	
AM System:	SLS	
Material:	Polymer	
Source:	Assa Ashuach	

Previous Design Feature

Next Design Feature

Back

Print

Figure 112: Feature example under the customised form

Table 3 shows which feature categories are enabled based on the concept profile buttons selected.

Profile Options	Enabled Categories	Reasons for AM
Does the product need custom fitting that conforms to an individual user?	Customised Profiles Features & Customised Form	User fit requirement
Does the product need to be lightweight?	Weight Reduction Features	Improve functionality
Does the product need to be hand held?	Increase surface friction features & Dual Material Features	
Does the product have internal structures?	Internal structural features & Instant assembly features	
Does the product benefit from being made available in a range of sizes or shapes to fit different users?	Multiple version features	
Does the product benefit from parts reduction?	Instant assembly features & Fasteners removal features & Multiple functions parts	
Does the product need to be attached to other components?	Fasteners removal features	Parts consolidation
Does the product benefit from having several other functions?	Multiple functions parts	
Does the product require over moulding?	Dual Material	
Does the product need to be aesthetically pleasing?	Embossed features & Surface features & Visual features	Aesthetics
Does creative and innovative shape or geometry an important factor for the product?	Customised form features	

Table 23: Result of concept profile selection

At the conceptual design stage a user might choose any of these features to be adapted for use within their concept design. Each of the features in the DfAM feature database has information associated with it such as the reason for AM utilization,

taxonomy sub category, name of the design feature, area of application, functionality keywords, the AM system used, type of material used and the designer who created the feature. As well as using the Microsoft Access forms to navigate the database, a designer with experience of using the system could go directly to certain types of features. To facilitate this, a quick keyword search operation was also added to the system. Figure 113 shows the quick search function that enables a user to find specific features or information from the database. In addition, the database can simply be browsed through by clicking on the “previous design feature” and “next design feature” buttons. Although not yet implemented, the database forms have been designed to allow users to add new features of their own into the system. The fact that the design features are presented visually would be likely to be of particular benefit to industrial designers who tend to work visually.

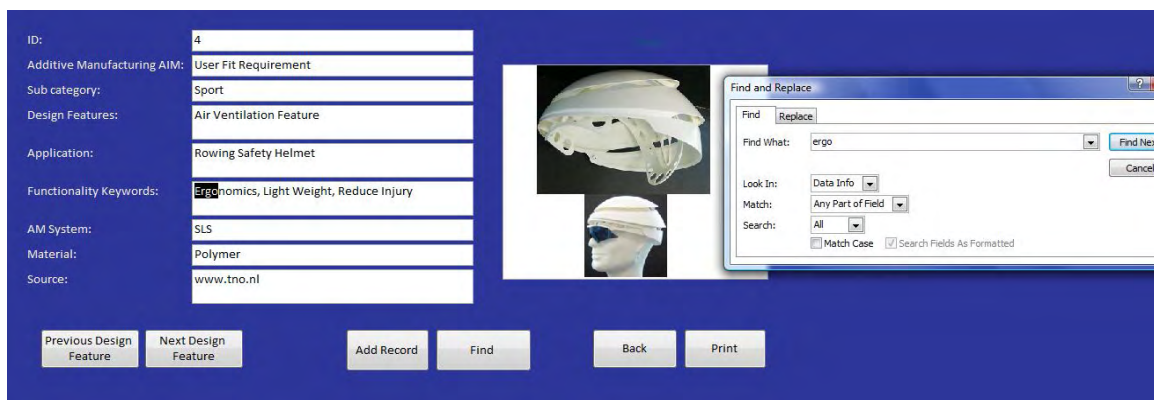

Figure 113: Quick Search Screen

Appendix B, C, D and E show all the design features that have been collected and grouped under the thirteen subcategories of applications. The images currently used in the database have been sourced from various websites, literature and personal contact with the designers. Therefore, permission would need to be sought from the owners of the images before the system is made available publically in any form. The feature database contains macros and visual basic scripts that could not be made available online at the time of writing this thesis. To make the tool available online the macros in the database could be converted to JavaScript and another option is to use Microsoft SharePoint 2010 and Microsoft Access 2010 which is not yet available at Loughborough University.

6.4 Summary

A strategic AM part or product design aid tool that evaluates the appropriateness of AM as a method of production and then suggests applicable design features base on the concept profile selected has been developed. The DfAM feature database “rapid prototyping” software approach that has been developed allowed the design of the system to undergo several iterations. The details of the database presented here are from the final version of the system. The process of the database testing and validation to study its effectiveness and its usability as well as to gather suggestions for its improvement are described in the next chapter.

Chapter Seven – DfAM Feature Database Validation

7.0 Chapter Overview

This chapter describes the validation that was undertaken to assess the effectiveness, usability and relevancy of the DfAM feature database. This chapter describes the methods used for validation and the findings from the validation.

7.1 Introduction

The implementation of the DfAM database using MS Access as a prototype software took place over a period of several months, during which time a number of revisions and improvements were made. Prior to the formal user validation, two postgraduates from Loughborough Design School participated in a series of smaller trials to establish a suitable format and time allocation required for the formal validation. For the validation, an exercise was devised in which four postgraduate students from Loughborough Design School participated. Although the number of participants in this validation was small, the design skills and knowledge of the participants meant that they were regarded as being competent industrial designers. Generally, the students have had exposure to product design for conventional products and had used AM technology in their projects due to the nature of the engineering and design courses they undertook. Their backgrounds are described below:

- ✓ The first participant holds a BEng in Product and System Design from the University of Aegean in Greece and an MSc in User Centred Product Design from Loughborough University. He has worked as a freelance web and graphic designer and as a junior Designer at Kelyphos Aqua Lab in Greece for six months.
- ✓ The second participant received a BEng in Mechanical Engineering from Beijing University of Aeronautics and Astronautics and an MSc in Virtual Product Design from Loughborough University. She has worked as a designer at Gongmei Group Co. Ltd. Technology Centre in China. She is now a full-time PhD student at Loughborough Design School. Her PhD focuses on Optimising Additive Manufacturing for Artistic Sculpture.

- ✓ The third participant is an industrial designer, specialising in Computer Aided Design, Modelling and Manufacture (CAD/CAMM). Upon graduating with a BSc in Industrial Product Design from Loughborough University in 2008, she spent six months as a freelance 3D CAD designer, then a further five months helping with a collaborative project involving the Design and Technology Association and Loughborough University. She is now a full-time PhD student at Loughborough University within the Loughborough Design School. Her PhD focuses on the digitisation of the splinting process for the upper extremities using 3D CAD and AM technologies.
- ✓ The fourth participant holds a BA in Industrial Design from Nan Jing Astronautics and Aeronautics University and an MSc in Industrial Design from Loughborough University. She worked as a designer at Nanjing Oai Product Design Company in China for one year and at Suzhou Zhenyi Advertisement Company Co, Ltd in China as a Design Assistant for one year.

7.2 Validation Method

The purpose of the trial was to compare the actual design of products when using and not using the DfAM feature database to understand its usability and effectiveness. The choice of the product chosen for the trial was suggested by the author and approved by the research supervisor. To keep the trial within a specific time frame and to ensure a reasonable complexity of product, the participants were requested to redesign any hand held device or a product of their choice. Although the products chosen were relatively simple, the principles that have been applied would be valid for more complex products.

The students were given two sets of design briefs. The first design brief requested them to redesign any hand held device or product of their choice for production via any conventional manufacturing method (refer to Table 25). The participants were encouraged to refer to various other sources of information such as patents, the internet and literature to gather ideas to develop the product form, function, aesthetic and ergonomics factors. They were given a week to complete the task of developing the conceptual sketches and initial CAD model of the product.

**Product Concept Redesign Brief (First Trial)
(Without Design for Additive Manufacturing (DfAM) feature database)**

1. Aim of Trial

To test redesigning of products that is to be produced using any conventional methods of manufacturing.

2. Synopsis:

The focus of this trial is to redesign a product (any hand held devices or a product of your choice). You are required to produce one redesigned concept sketch that lends itself to production via any conventional methods of manufacturing. Finally, you will be given a week to produce the CAD model of the redesigned concept sketch.

3. Design trial:

- i. You are required to produce one redesigned concept sketch with some text annotations using paper base sketches.
- ii. You are encouraged to use any material, information or website to assist you in this trial.

4. Estimated time:

- i. Introductory lecture and preparation – 5 minutes
- ii. Product concept redesign exercise – 45 minutes
- iii. CAD – 1 week

Table 25: Design Brief for First Trial

The second design brief requested them to redesign the same product as the first trial for production via AM (refer to Table 26). They were given the DfAM feature database to aid them by giving visual information of features that could be added into the product. The focus of the second trial was to redesign the product to have its functionality, aesthetics, ergonomics or parts consolidation improved through the use of AM. Once again, they were given a week to develop the conceptual sketches and initial CAD model of the product. They were asked to present the conceptual sketches as annotated sketches, indicating where they have added features from the database. The justification of using the same students to develop the same product for both trials was to enable direct comparison of products developed with and without the database. It was also to enable a consistent result due to the design skill and knowledge they used in developing the product.

The availability of free time in which to conduct the validation was a problematic issue for all of the participants who were invited to take part. To solve this problem, the exercise was structured so that ample time was given to the participants to produce the sketches and the CAD model according to their own schedule. The participants were free to choose the product that they were to redesign using their own preferred design medium and in a surrounding of their own choosing. They were requested to complete the sketches and the CAD model for the first and second trial within a total of two weeks. After completing both trials, the students were asked to provide questionnaire feedback on the benefits of using the DfAM feature database and to rate the usefulness of the database as a source of information to aid product development for AM.

Product Concept Redesign Brief (Second Trial)
(With Design for Additive Manufacturing (DfAM) feature database)

1. Aim of Trial

To test a new design aid tool in a form of a design features database to see if it is relevant, effective and applicable to aid designing of parts or products that are to be produced using Additive Manufacturing (AM) process particularly the laser sintering process.

2. Overview:

AM has the unique capability of being able to produce low volume, customised and complex shape of parts or products. AM also allows component integration and provide designers freedom to explore new product concepts.

3. Synopsis:

The focus of this trial is to redesign the product that you have chosen during the first trial, to improve its functionality, aesthetics, and ergonomics or to reduce the number of parts that lends itself to production via AM. You are required to produce one best concept redesign of the product. You will be given the Design for Additive Manufacturing (DfAM) feature database that contains examples of design features from various applications that has been collected and grouped under four categories of AM reasons of utilisations. You are required to take advantage of designing for AM by adding or applying as many relevant design features from the database to your sketch and produce a creative and innovative design solution. Finally, you will be given a week to produce the CAD model of the redesigned concept sketch.

4. Design trial:

1. You are required to produce one concept design with some text annotations using paper base sketches.
2. The DfAM features repository that will be supplied with this trial contains various examples of design features that intended to provide inspiration to aid in the concept design.
3. You should consider as many of the aesthetics or ergonomics features that would be applicable to your chosen product.
4. You should consider how to improve the product functionality.
5. You should consider reducing the parts number if it is possible.

5. Estimated time:

1. Introduction to the DfAM feature repository– 10 minutes
2. Product concept redesign exercise – 45 minutes
3. CAD – 1 week
4. Complete feedback questionnaire – 10 minutes

Table 26: Design Brief for Second Trial

7.3 Trial Results

Table 27 shows the products redesigned by the participants. In total, eight sets of sketches and eight 3D CAD models were collected from the students.

Student Designer	Product Redesigned
1	Juice Squeezer
2	Electric Beard Shaver
3	Cold sore treatment wand
4	Hand held Electric Blender

Table 27: Products Redesigned by the Participants

Student designer number one chose to redesign a juice squeezer. Figure 114 shows the sketches of the juice squeezer that were produced for production via conventional manufacturing, specifically injection moulding. Using the sketch as a reference, the designer generated the 3D CAD model that represented its form and features (Figure 115). The juice squeezer shows that the handle and the tip of the squeezer will have to be manually assembled in order to use it. Figure 116 shows the sketches of the juice squeezer that were produced for production via AM with the aid of the DfAM feature database. Figure 117 shows the 3D CAD models that represent the design produced. Detailed observation of this 3D CAD model reveals a number of features that are only possible with AM. These include non-uniform wall thickness and undercut geometries of the fruit seed holder. It also demonstrates the capability of AM to consolidate component parts, reducing assembly operations and the costs that would be associated with them. Instead of having two separate parts as in Figure 115, the redesigned product for AM shows that the juice squeezer was made into a single part and utilised the hand grip contour feature and dual AM material feature for better gripping and ergonomics.

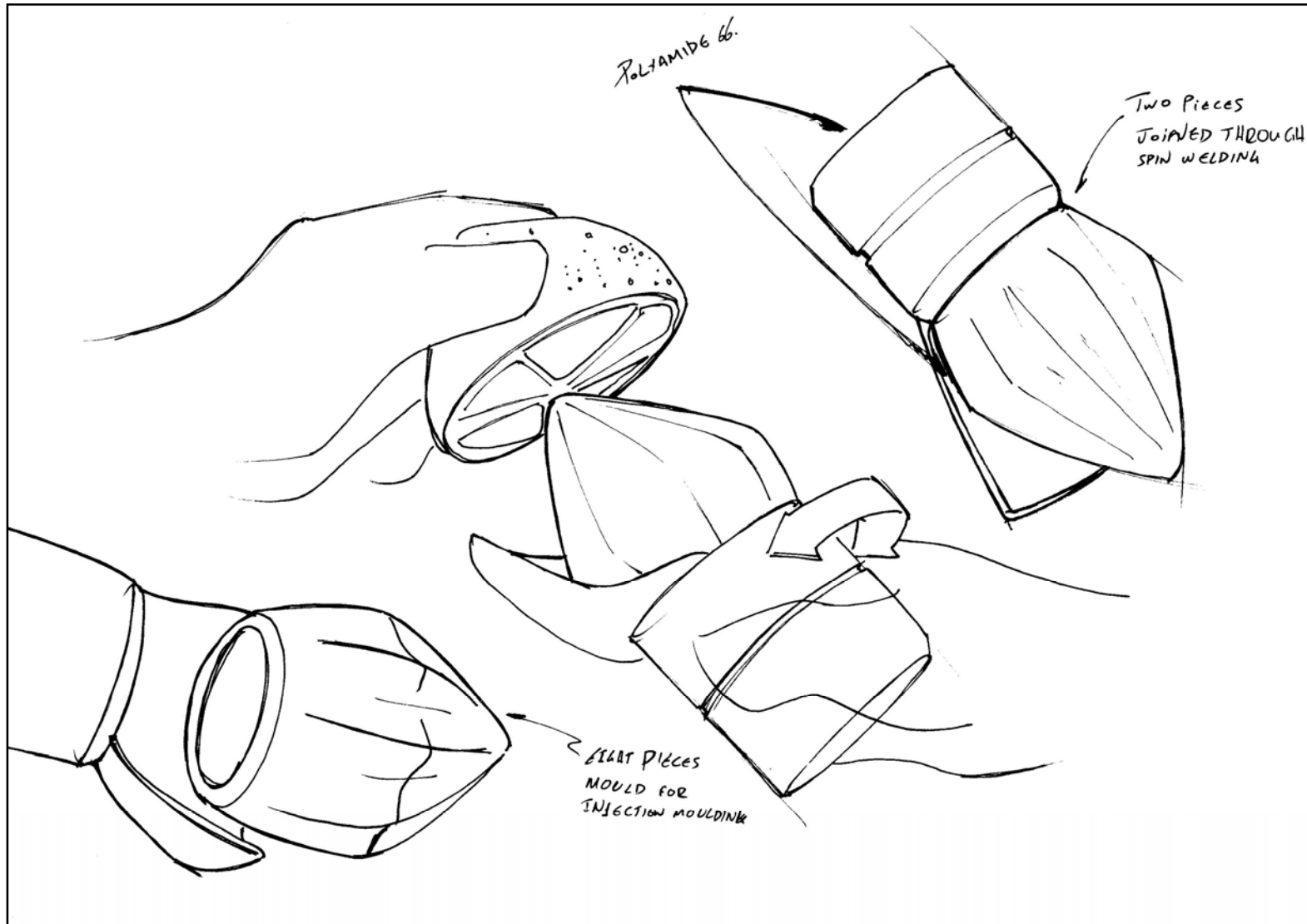

Figure 114: Juice Squeezer sketch without using DfAM feature database

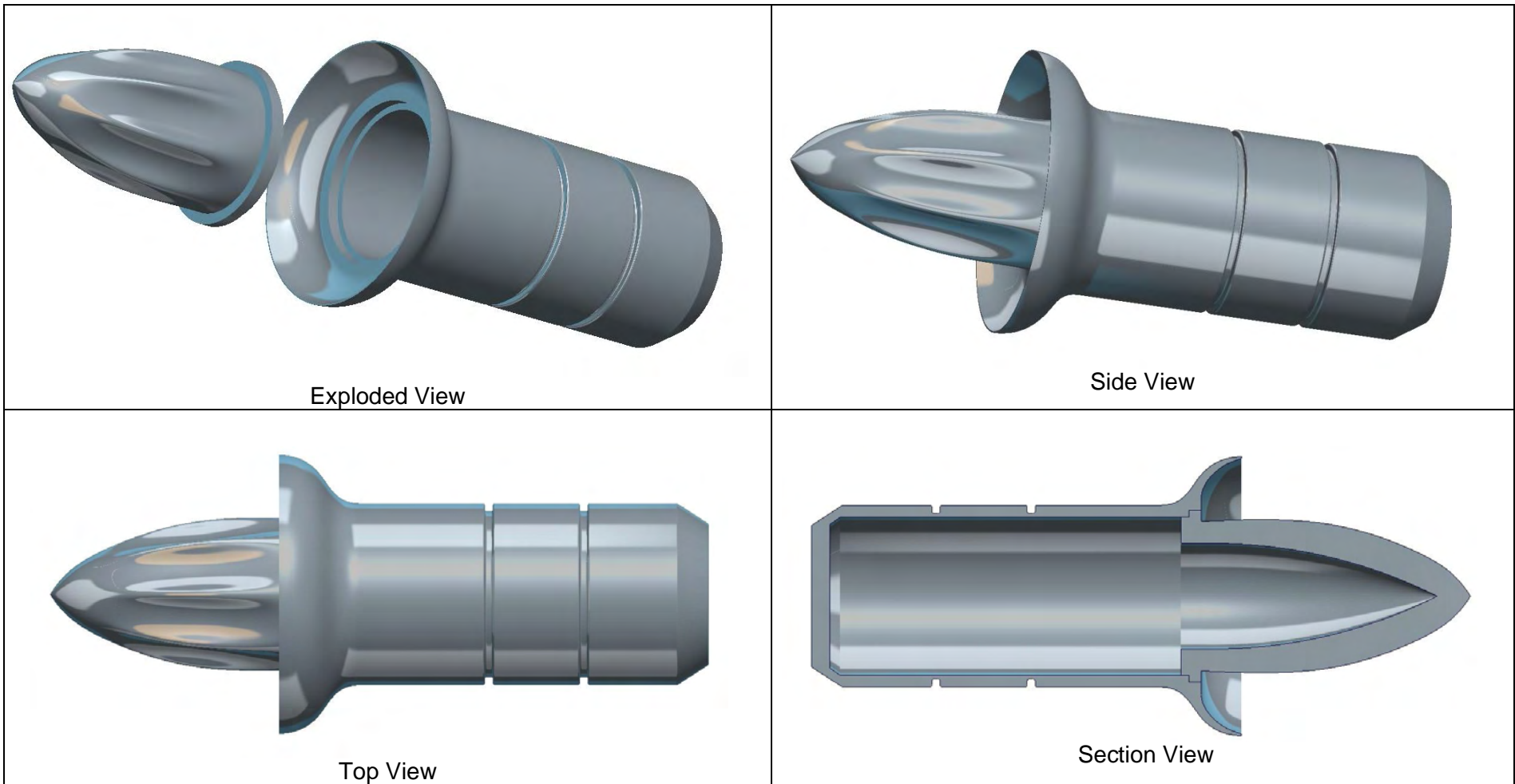

Figure 115: Juice Squeezer 3D CAD for Injection Moulding

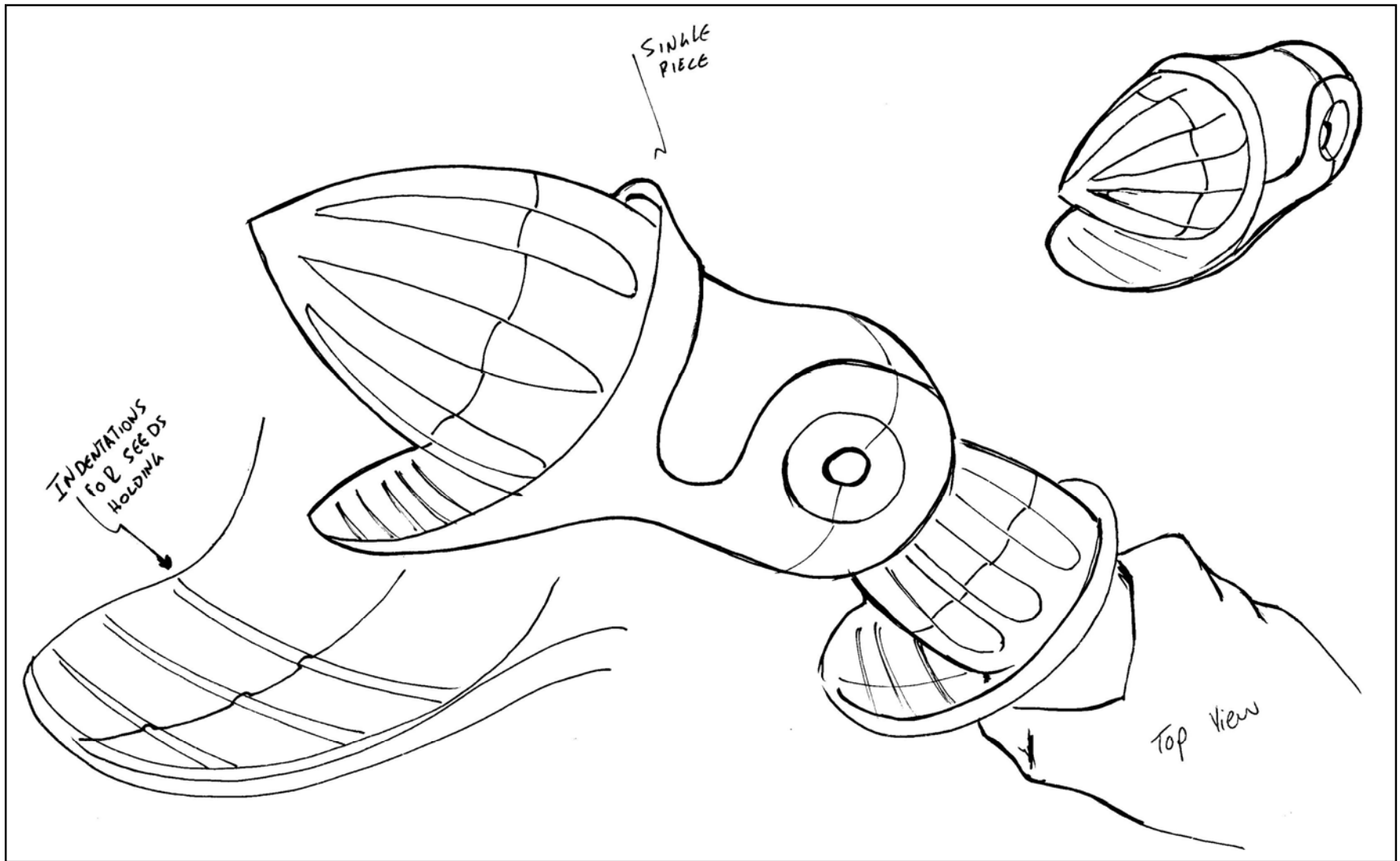

Figure 116: Juice Squeezer sketch using DfAM feature database

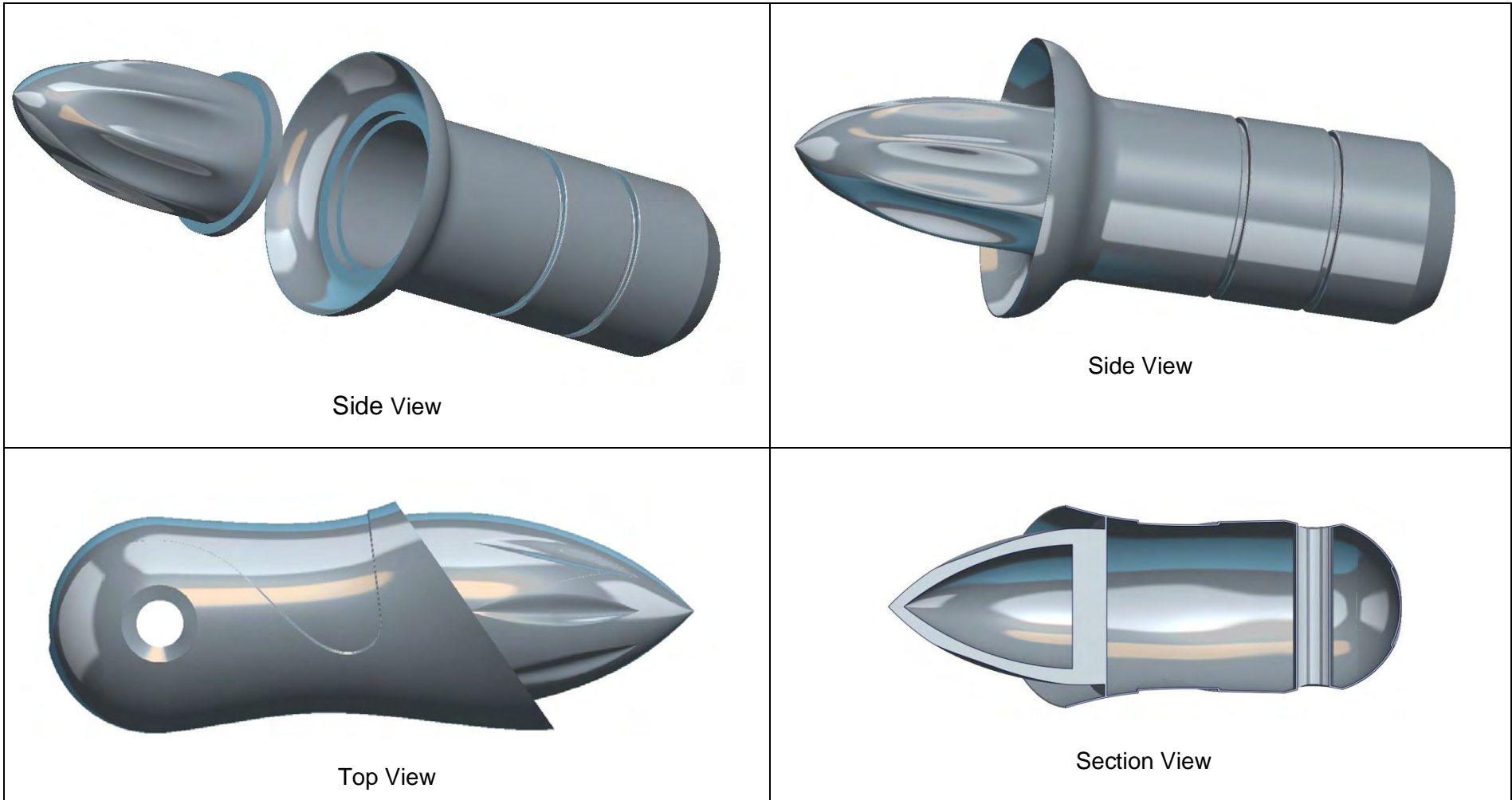

Figure 117: Juice Squeezer CAD with using DfAM feature database

Student designer number two chose to redesign an electric beard shaver. Figure 118 shows the sketches of the shaver that were produced for injection moulding. Using the sketch as a reference, the designer generated the 3D CAD model that represented its form and features (Figure 119). Detailed observation of the 3D CAD model shows a typical form of a hand held shaver.

Figure 120 shows the sketches of the shaver that were produced for production via AM with the aid of the DfAM feature database. Figure 121 shows the 3D CAD models that represent the design developed. Detailed observation of the second CAD model shows that the shaver has a compact and free form geometry for better ergonomics and it has transparent cases which are designed to improve its aesthetics aspect. Features that were added from the database is the perforated surface feature that is built in as second AM material which provides a soft and tactile grip for improved ergonomics aspect of the shaver. This feature is not shown in the CAD models due to the complexity to design it. Other features that were added from the database are the weight reduction features i.e. the thin wall feature to make the shaver lighter (also applied to the shaver cases). The internal parts of the shaver were consolidated requiring less assembly, this can be seen at section view 1, section view 2 and for the switch. The fasteners removal features (such as the hook clip to fasten the parts) were also added to the design. The design was also subject to varying wall thicknesses, where material was used to selectively strengthen and support areas that accommodate the mechanical parts within the shaver (refer to section view 2 and the switch). Whilst these geometric features would be a problem for conventional processes, they are achievable with AM. Even though all these features can be manufactured with conventional processes, it is however not economical to produce as a one off product. Therefore, AM would be beneficial in this case.

The shaver redesigned for AM clearly demonstrates the capability of AM to consolidate component parts, reducing assembly operations and the costs that would be associated with them. The freedom of geometrical creation associated with AM has been used that would otherwise be difficult to produce with conventional processes. The shaver redesigned for AM also possesses better aesthetics and ergonomic characteristics.

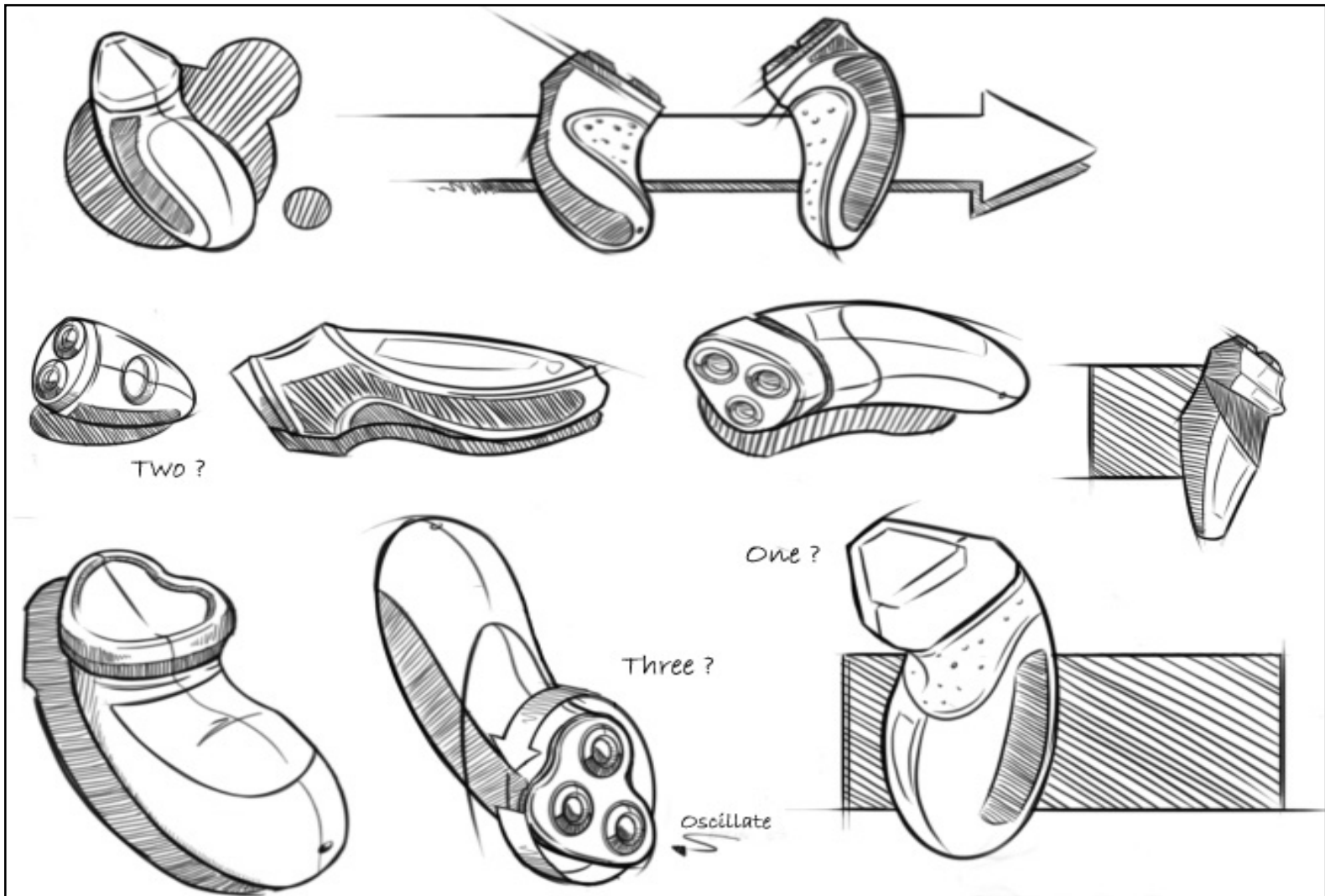

Figure 118: Shaver sketch without using DfAM feature database



Figure 119: Shaver CAD without using DfAM feature database

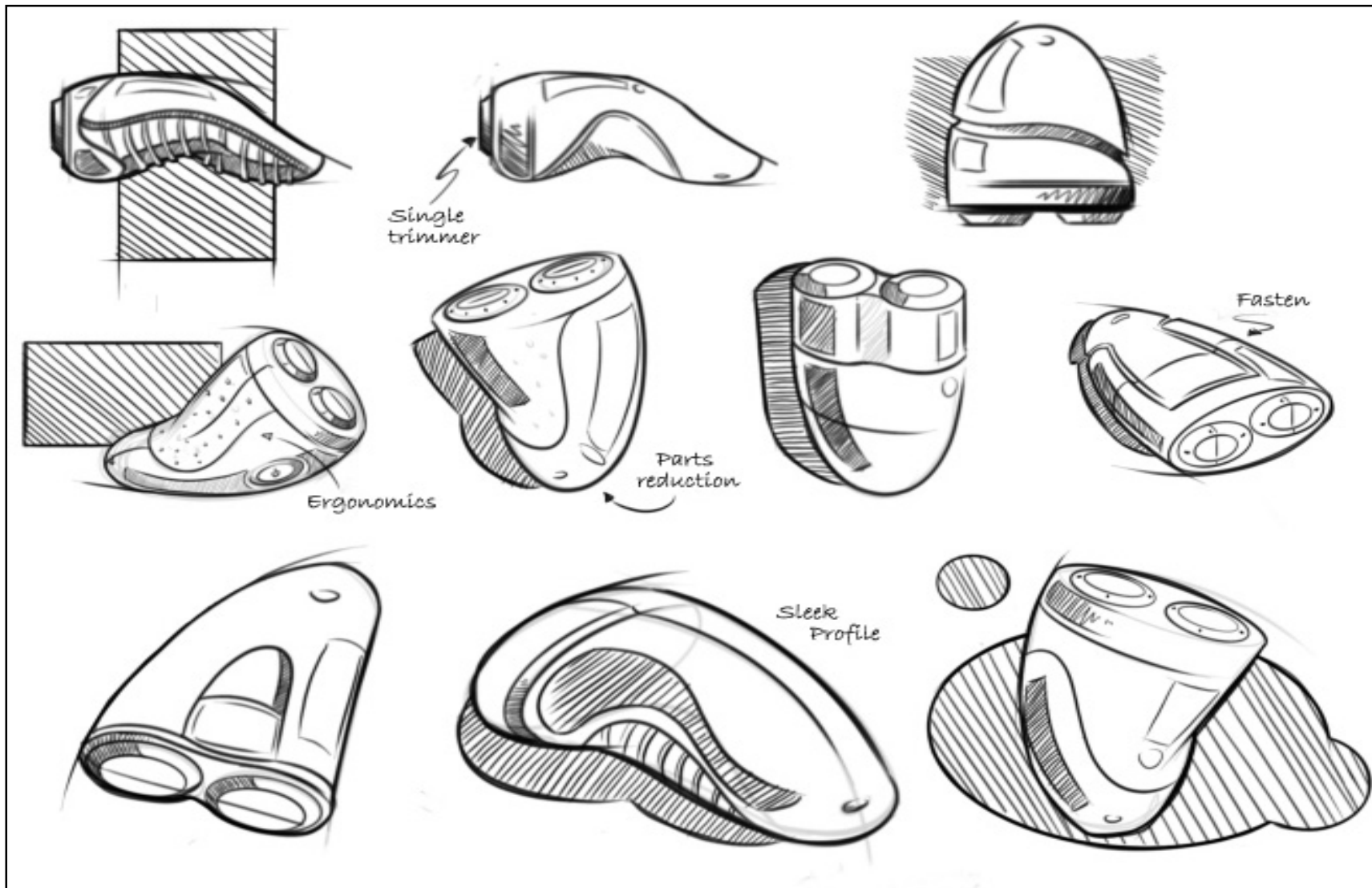

Figure 120: Shaver sketch using DfAM Feature Database

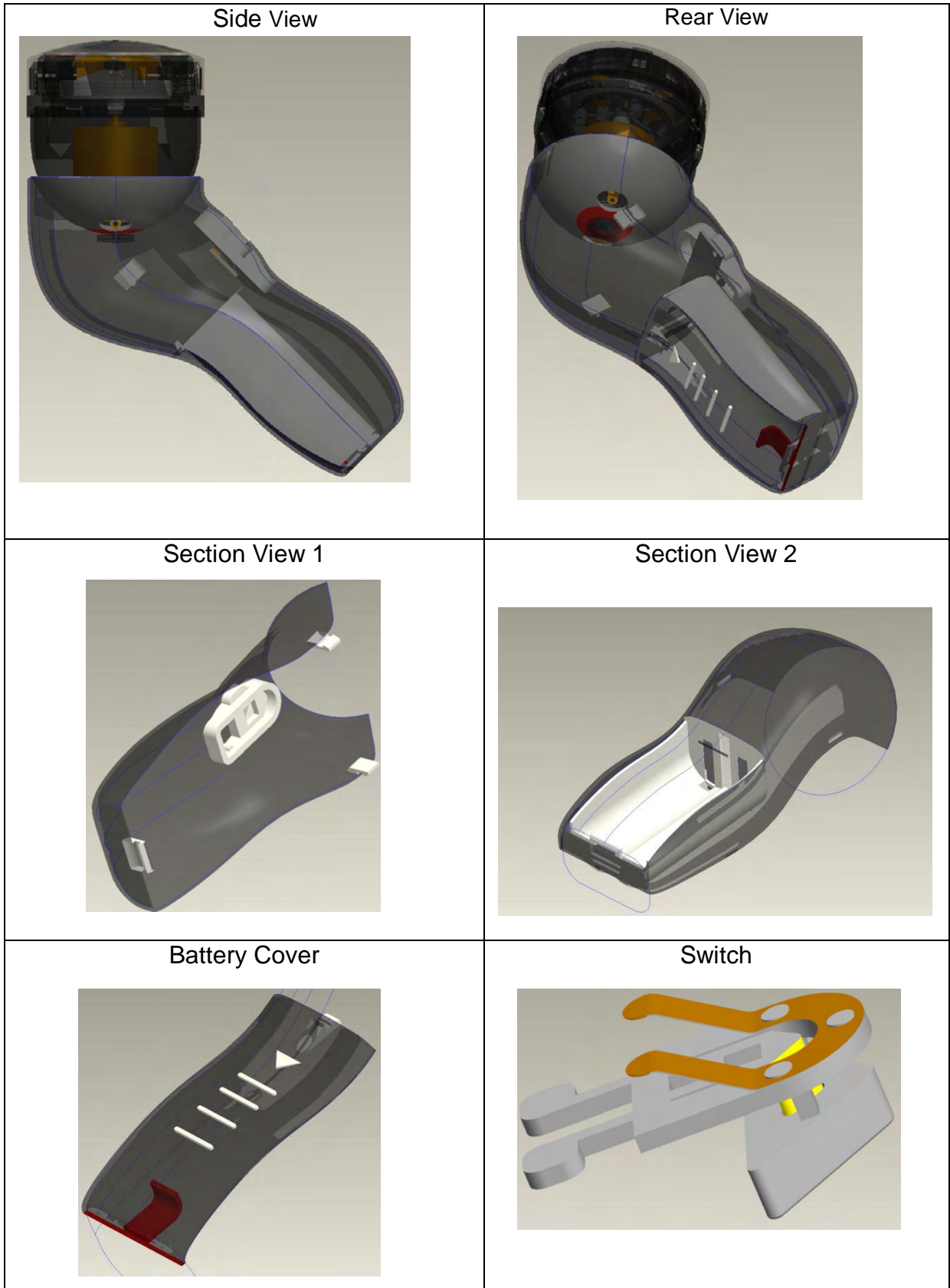

Figure 121: Shaver 3D CAD using DfAM Feature Database

Student designer number three chose to redesign a hand held cold sore treatment wand. The product emits red light to stimulate cell re-growth to speed up the healing process. Figure 122 shows the exploded sketches showing seven different parts of the product. Figure 123 shows the sketches of the product that were produced for injection moulding. Using the sketches as a reference, the designer generated the 3D CAD model that represented its form and features (Figure 124). Detailed observation of the 3D CAD models shows a typical form of a hand held cold sore treatment wand.

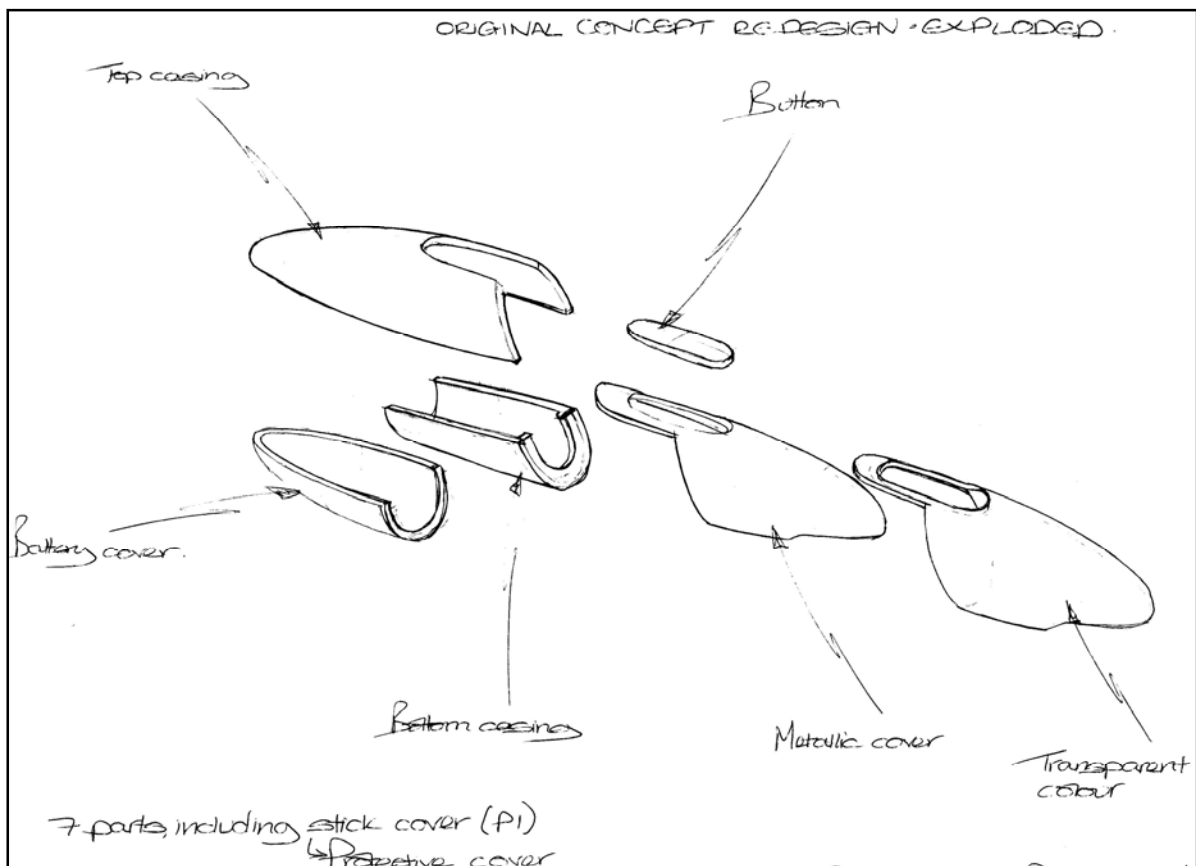

Figure 122: Exploded Sketch of Cold Core Treatment Wand

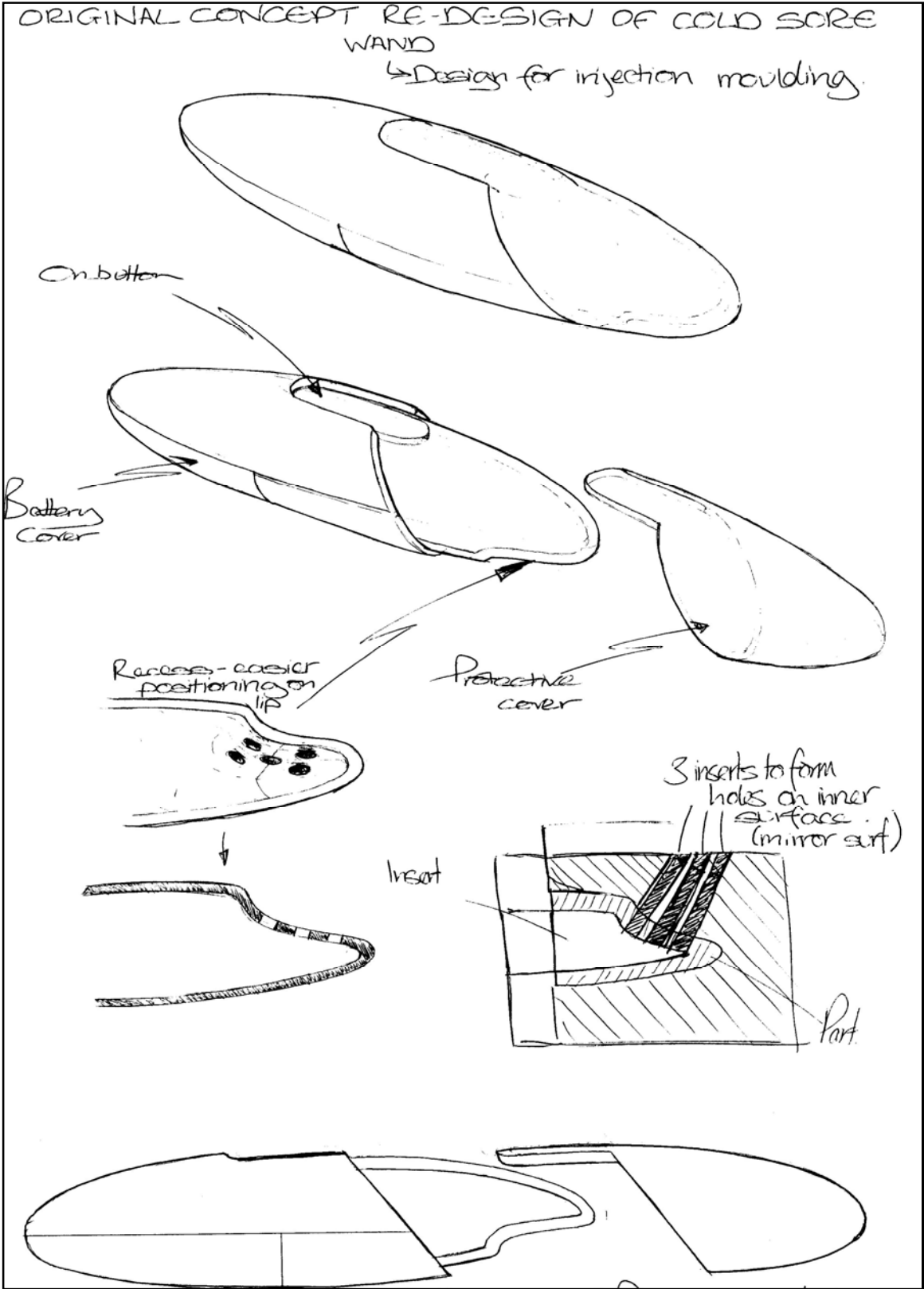

Figure 123: Cold Core Treatment Sketch for Injection Moulding

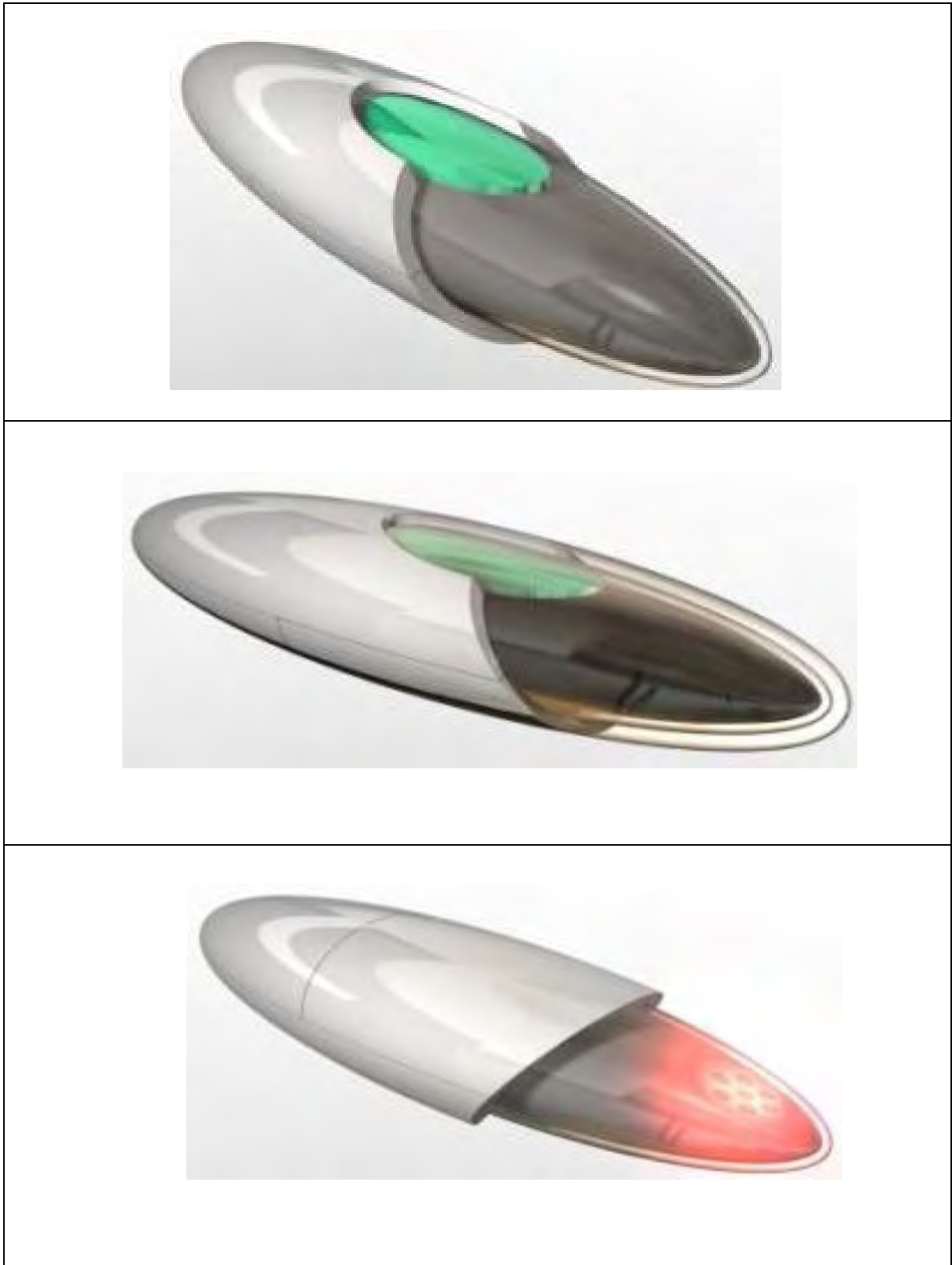

Figure 124: CAD Model of Hand Held Cold Sore Treatment Wand for Injection Moulding

Figure 125 and Figure 126 show the sketches of the cold sore treatment wand that were created for production via AM with the aid of the DfAM feature database. Figure 127 shows the 3D CAD models that represent the design developed. Detailed observation of the second set of sketches shows that the cold sore treatment wand has been build into a single component making use of the parts consolidation capability of AM. The battery cover is integrated into the main compartment by making use of the living hinge feature from the database. Other mechanical components and electrical circuits can be assembled through the battery compartment. Furthermore, improvement of the lip placement area by having a more prominent curve for lip location has been made that improves the ergonomics aspect of the product. A form of meshing feature was applied to the area indicated in red was also made to trap simple virus or other germs. In order to have a soft and tactile grip the product has been designed to be produced with dual AM materials.

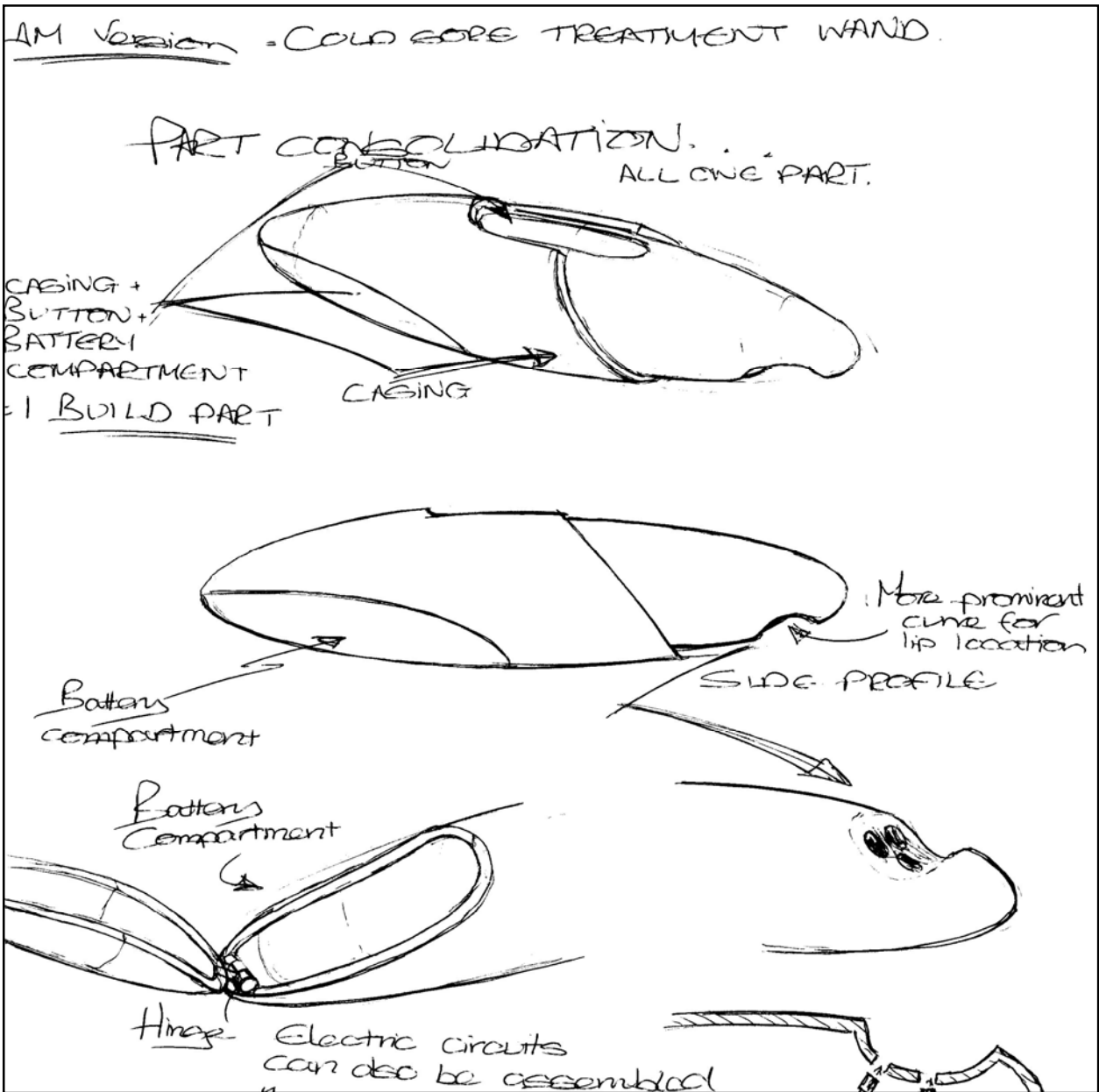

Figure 125: Cold Sore Treatment Wand Sketch for AM

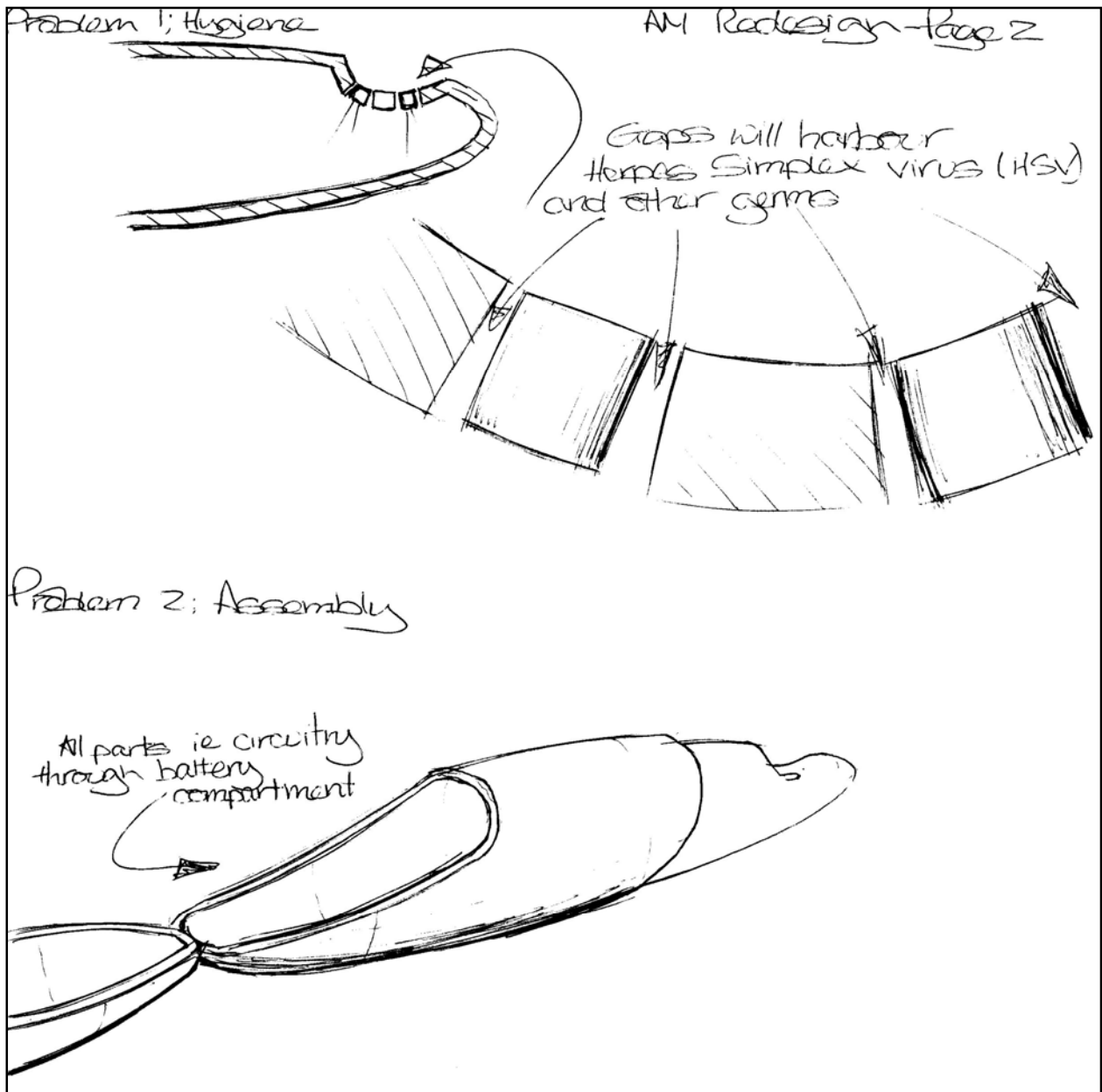

Figure 126: Cold Sore Treatment Wand Section View Sketch for AM

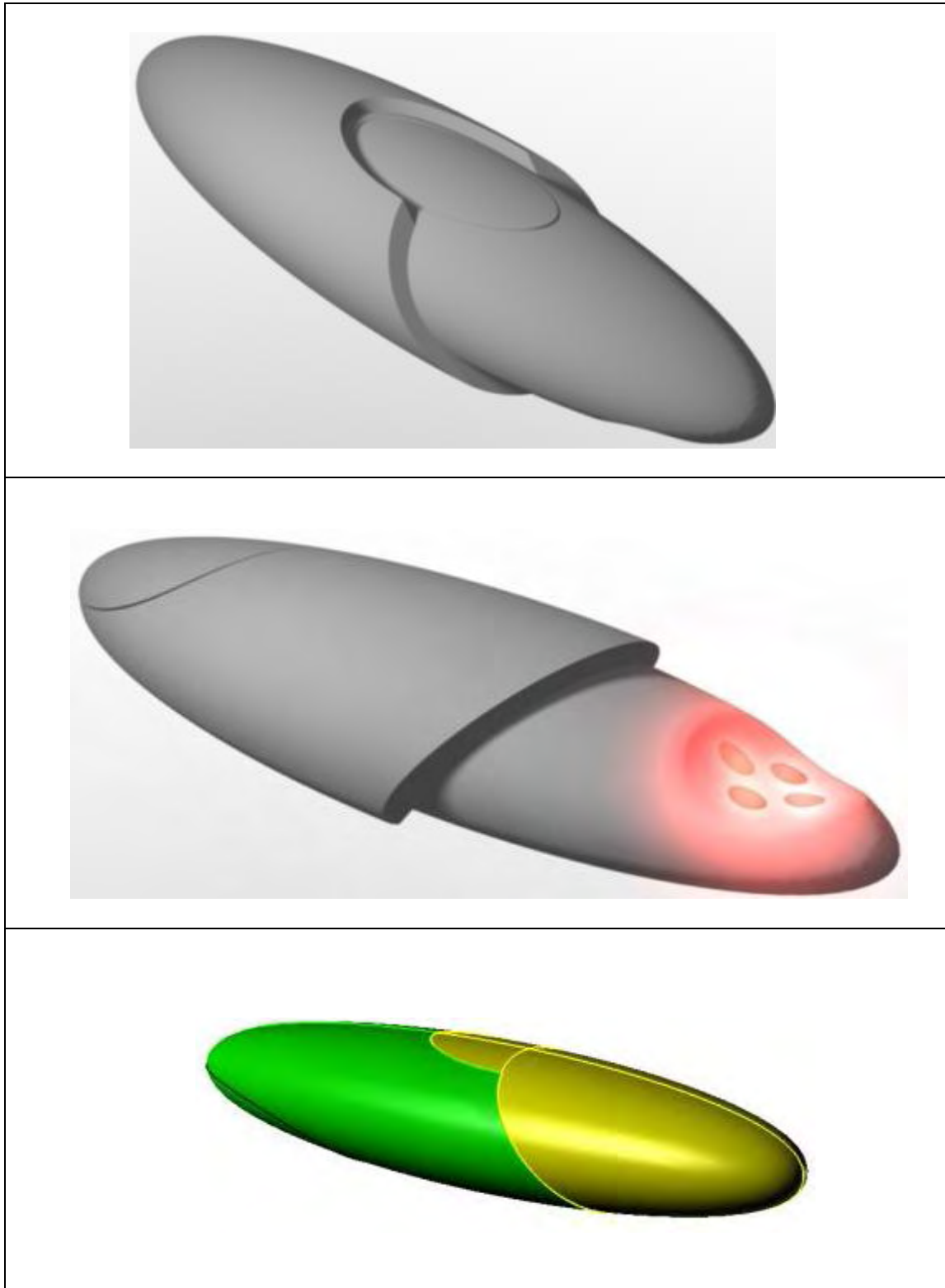

Figure 127: 3D CAD Models of Hand Held Cold Sore Treatment Wand for AM

Student designer number four chose to redesign a hand held kitchen blender. Figure 128 shows the sketches of the product that were produced for injection moulding. Using the sketch as a reference, the designer generated the 3D CAD model that represented its form and features (Figure 129). Once again, the sketch produced without the aid of the database does not indicate any distinctive design features.

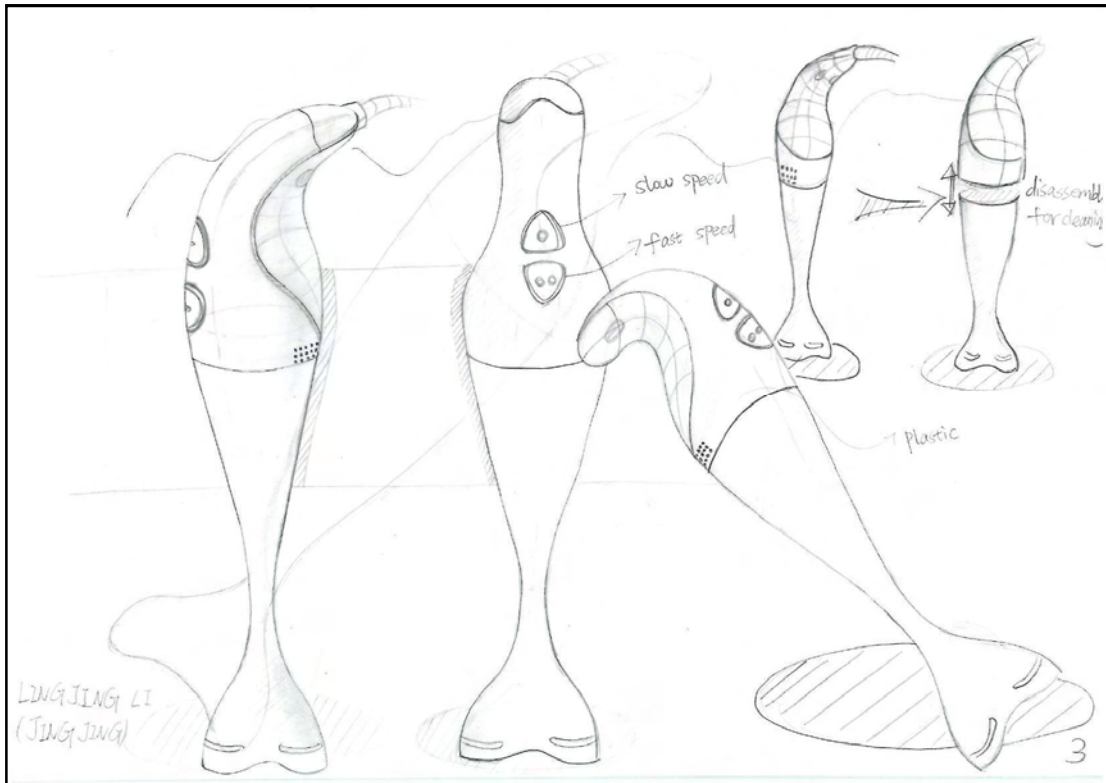

Figure 128: Sketch of a hand held kitchen blender for injection moulding

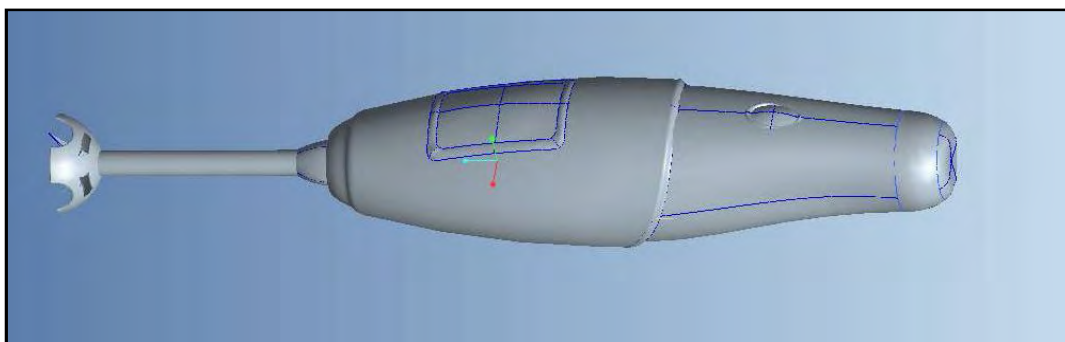

Figure 129: 3D CAD models of hand held kitchen blender for injection moulding

Figure 130 shows the sketches of the hand held kitchen blender that were created for production via AM with the aid of the DfAM feature database. Figure 131 shows the 3D CAD models that represent the design developed. Detailed observation of the second set of blender sketches shows that the handle has been designed to be build with dual AM materials in the hand contour feature to provide a firm grip. This also provides an improved aesthetic and a handle design that looks like part of the structure, rather than being bolted on. The design was also subject to varying wall thicknesses, where material was used to selectively strengthen and support areas of weakness and high stress for instance for the speed regulator as shown in Figure 130.

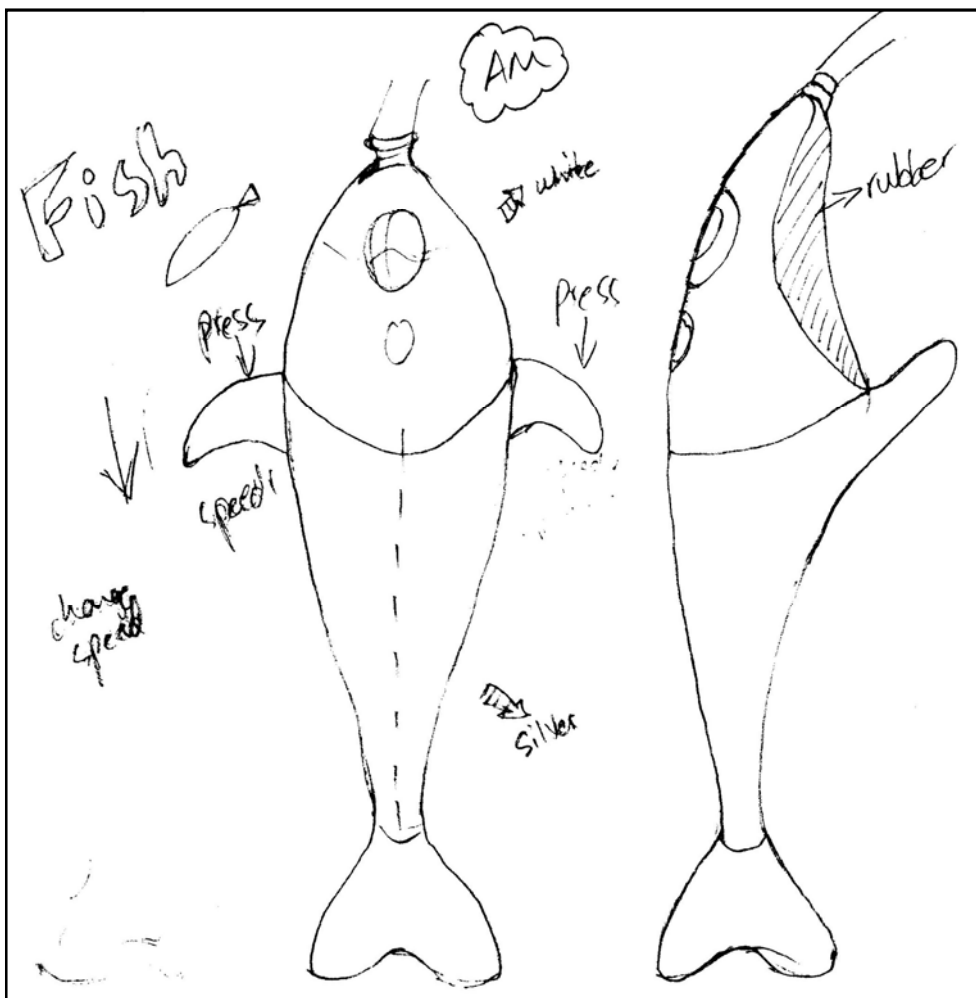

Figure 130: Sketch of a hand held kitchen blender for AM

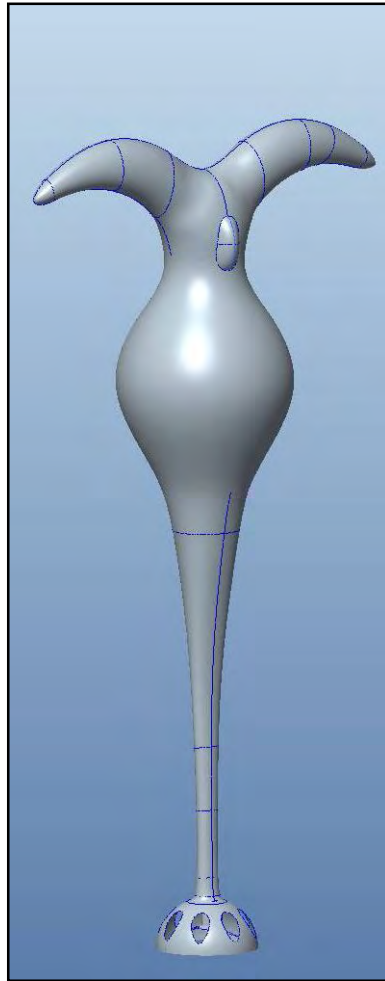

Figure 131: 3D CAD model of hand held kitchen blender for AM

7.4 Results Analysis

The analysis of the sketch and CAD results found that there were two factors that influenced the quality of the redesigned products. The first was the level of 3D CAD form creation capabilities of the individual student designers, which was seen to influence their creativity causing a “natural variation” in design quality. One challenging area noted was the transformation of the paper-based sketches into 3D CAD models in which the exact reproduction of the design intent was not always achieved. In this study, it appears that CAD represents a design bottleneck for the student designers. Due to this, the time taken to produce the CAD models was more than the time taken to create the sketches. The second factor that influenced the quality of the redesigned products was the number and range features added from

the database into the products. As most of the products redesigned were hand held devices which were relatively simple, there were not that many features from the database which were suitable for adding to the product redesigned for AM. This limited the student designers to applying only a few features from the database. The number of features is likely to be greater and more varied if more complex products were chosen for the trial. However, this would have made the length of trial unacceptably long.

Table 28 shows the range of the features added from the database. An overall observation of the list shows that the student designers applied features from all four reasons of AM utilisation categories. The weight reduction features, instant assembly features, fasteners removal feature and the transparent feature under the aesthetics or form requirement were most applied in the designs. The feature that was used most from the feature database was the dual AM material feature, which can give a similar result to over-moulding. As most of the products were hand held, this was an important feature to be applied. However, only the hand grip contour feature was applied from the customised profile feature. As most of the design features in the user fit requirement are collected from specific application areas such as medical, sport and consumer products, the students may not have considered them as being relevant to their assigned products. In summary, Table 28 shows that the feature database was relevant and usable by the students to support the product design activity by providing them visual information of features that could be added when designing a product for AM. Furthermore, Table 28 shows that many of the features that the designers saw as being relevant to their product design for AM were held within the database.

By analysing and comparing the sketches produced by the student designers when using the DfAM feature database, it was found that the tool did seem to provide the students with ideas on how to incorporate various features into their products. The sketches produced indicated that when using the DfAM tool, the student designers were able to apply design features such as variable wall thickness, living hinges, dual AM material, transparency and various surface features that were rarely seen in the “without use” sketches. This suggests that the DfAM tool is a useful thought provoker during the more conceptual stage of design. In addition, the fact that all the

students were able to translate most of their AM-enabled features through to realisable 3D CAD models also shows that the tool is valuable for detail design.

			Student Designers			
AM Reason	Application	Design Features	1	2	3	4
User Fit Requirement	Customised Profiles Features	Hand Grip Contour	X			X
Improve functionality requirement	Weight Reduction Features	Undercut Feature	X	X	X	X
		Thin Wall Feature		X	X	
		Variable Wall Thickness Feature	X	X		X
Consolidation Requirement	Increase Surface Friction Features	Textured Surface Feature		X		X
	Internal structuring feature	Internal Shelving		X	X	X
	Instant Assemblies Features	Living Hinge Feature			X	
	Fasteners Removal Features	Hook clip		X		
		Snap fit hook				X
Dual material	Over Moulding	X	X	X	X	
Aesthetics or Form Requirement	Visual Features	Transparent Feature		X	X	

Table 28: Range of features used from the DfAM feature database

7.5 Questionnaire Feedback Analysis

On completion of the design tasks, the students completed a questionnaire to gain feedback on their views of the usability, relevancy, effectiveness and applicability of the feature database. Eight questions were used to address these issues, of which seven questions were related to the key areas of gauging the tool's comprehensibility, methods of approach, usability, its functionality and its benefits. The last question was open ended asking for suggestions for improvement of the database. To ensure the validity and clarity of the questions, the questions were pretested with the author's supervisor who is an academic within Loughborough Design School. As a result, minor changes to sentence structure of the questions were made. The questions were as follows:

1. How do you generally feel about the effectiveness of DfAM feature database?
2. How do you rate the pictorial data and textual content of the database?
3. How do you rate the database approach that provides examples of design features that could be incorporate or added into you design work?
4. How do you rate the usability of the database in order to impart possible design features in product design for AM?
5. Does the database provide aid to understand the design freedom of AM?
6. Does the database help to enhance your design creativity?
7. Was your product design influenced when using the database?
8. Do you have any suggestions on how the DfAM feature database could be improved?

A combination of 5-point Likert scales, numeric scales and open ended questions was used to capture their responses and to provide a clear means to gauge participant opinions. The Likert scale was used because it is easy to understand and quantify compared to open ended questions. Fully completed copies of each questionnaire are contained in Appendix G.

In question one (Figure 132), an attempt is made to gauge the general effectiveness of DfAM feature database. With the exception of one neutral response, the students felt that the DfAM was effective as an aid to designing for AM. One positive comment was made in which the database was said to provide inspirations systematically. Other positive comments such as ‘It inspires me to think about new ideas that exclude traditional manufacture methods’ were also made. The ability of the tool to analyse the suitability of using AM for a certain product and the profile generation screen that suggest suitable features to be added into a product design was seen as being a useful aspect of the database. However, one response suggesting that the database is potentially very helpful for designers who are less familiar with AM was made. The responses to this question were as follows:

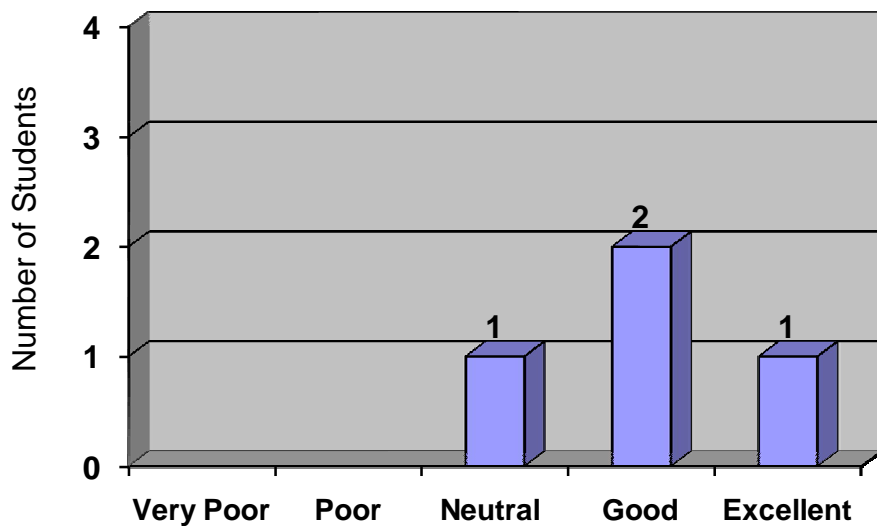

Figure 132: Responses to Question One

Question two (Figure 133) was used to determine the clarity of the pictorial data and the textual content of the database. With the exception of one negative response, the students agreed that the pictorial data and textual content of the DfAM system were clear and easy to understand. One student stated that the information given in each category was very vague and very limited. Suggestion to include a description or synopsis of each feature showing how LS had been used for their specific design process (maybe have 'before' and 'after' illustrations where applicable) was made. The responses to this question were as follows:

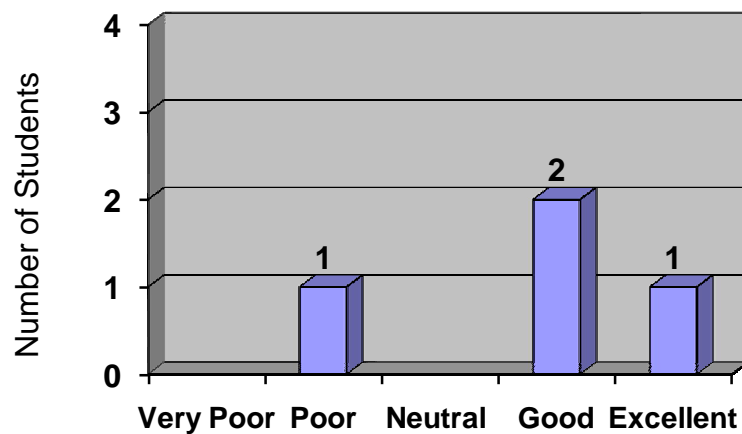

Figure 133: Responses to Question Two

In question three (Figure 134), the students were asked to rate the database approach. All the students felt that the DfAM approach, which provides example of design features that could be incorporate or added into their design work, was a good approach. However, there were no comments or suggestion given for this question. The responses to this question were as follows:

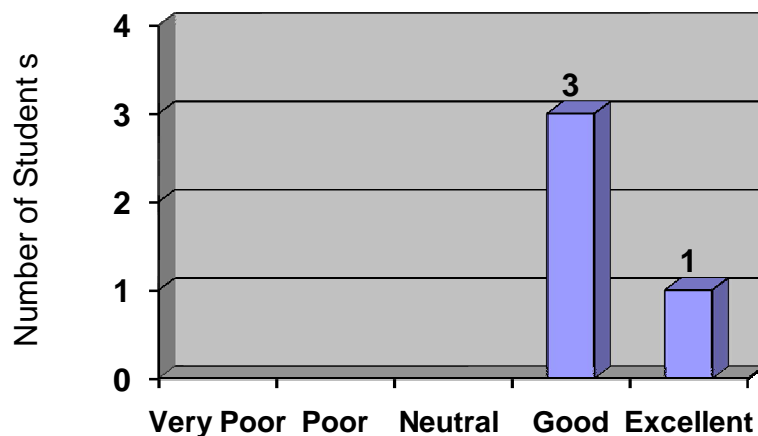

Figure 134: Responses to Question Three

In question four (Figure 135), the students were asked to rate the usability of the database. With the exception of one neutral response, the students felt that the DfAM feature database was useful in order to impart possible design features in their product design for AM. Two students commented that the database was very easy to use. The responses to this question were as follows:

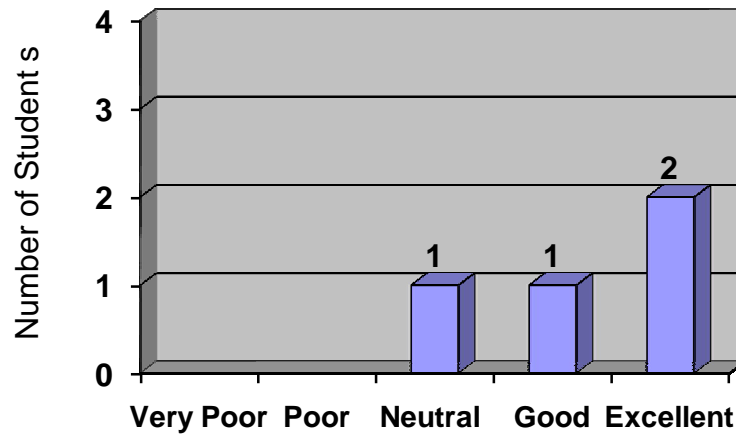

Figure 135: Responses to Question Four

In question five (Figure 136), the students were asked to rate if the database provides an aid to understanding the design freedom of AM. Again, with the exception of one neutral response, the students felt that the DfAM feature database was useful in helping to understand the design freedom. With regards to the neutral response, it was mainly due to the needs or constraints of the product being redesigned rather than the limitation of the database. A suggestion to have descriptions explaining each feature was given. The responses to this question were as follows:

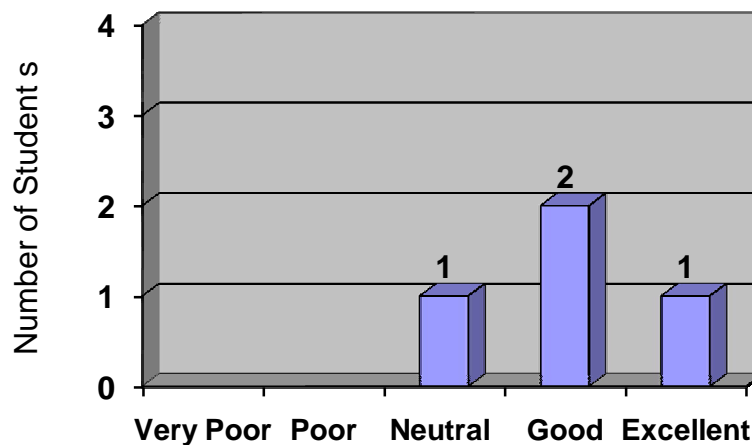

Figure 136: Responses to Question Five

In question six (Figure 137), the students were asked to rate if the database helped to enhance the students' design creativity. Again, with the exception of one neutral response, the students felt that the DfAM feature database was useful in helping to enhance the design creativity. With regards to the neutral response, it was again due to the needs or constraints of the product being redesigned and not the limitation of the database. The responses to this question were as follows:

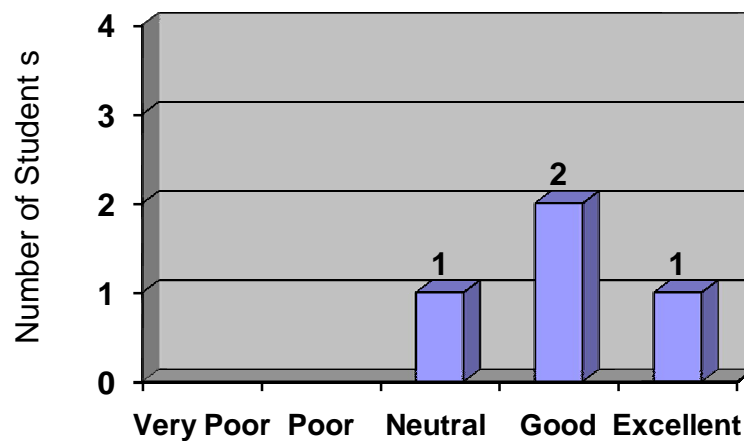

Figure 137: Responses to Question Six

In question seven (Figure 138), the students were asked to rate if their product design was influenced when using the database. With the exception of one negative response, the students felt that their product design was influenced indicating that the DfAM feature database was helpful and influential in their design work. The negative response for this question was not an indication of the limitation of the database, this is due to the characteristics of product being redesigned that hinder the usefulness of the database. The responses to this question were as follows:

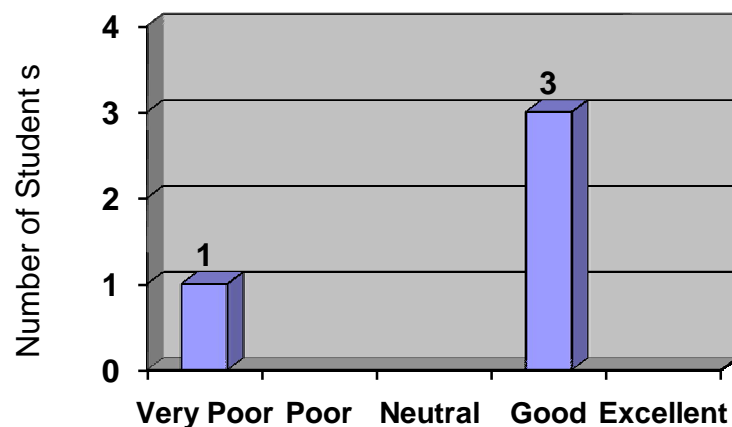

Figure 138: Responses to Question Seven

In question eight the students were asked to provide suggestions to improve the database. Some suggestions on how the DfAM feature database could be made more helpful are listed below:

- i. Add more examples of design features
- ii. Make the images bigger
- iii. Cater for all AM technologies

7.6 Chapter Summary

This chapter has described the validation of the DfAM feature database tool using two product design exercises. This chapter has presented four products that were redesigned to study the relevancy and effectiveness of the DfAM feature database. Comparison was made between each product when redesigned for conventional forms of manufacture without the aid of the DfAM feature database and when redesigned for AM with the aid of the DfAM feature database.

The freedom of geometric creation associated with AM was exploited to consolidate parts and improve product aesthetics, ergonomics and potential functionality, in shapes that would be impossible to produce with conventional processes. Features, such as hand contours, undercuts and variable wall thicknesses, have been included. Consolidation of multiple assembly components has also been demonstrated that could minimise assembly operations and reduce assembly cost. Analysis of the student sketches and CAD models and the questionnaires show that the DfAM feature database provided inspiration on how to incorporate various AM enabled design features into their detailed product designs.

Chapter Eight – Conclusions and Future Work

8.0 Chapter Overview

The previous chapter described the validation process conducted to verify the effectiveness, usability and relevancy of the DfAM feature database in assisting and providing inspiration to industrial designers when developing product design of products or parts for AM. This chapter provides conclusions to the research by addressing the objectives that were identified at the beginning of the research and commenting on how they were achieved during the course of work. It also provides a discussion on the research questions that were stated in Chapter One. Finally, some recommendations for future research are listed.

8.1 Research Objectives Achieved

A number of objectives were identified at the beginning of this research project. The following section describes these objectives and discusses how the various issues have been addressed.

1. To identify the methods, tools and strategies that are commonly applied within the practice of industrial design.

An initial literature review was conducted to study the practice of industrial design thus finding a number of systematic methods and approaches that have been used to assist industrial designers in the design and development process. Chapter Two has given some background on the understanding of the design process, design methodology and its development in today's world of design research. However, published work on methods to specifically support product design for AM was found to be limited.

2. To investigate tools, methods and strategies used to support AM.

The literature review in Chapter Three has explored various tools used to generate model data for AM systems. Conclusively, CAD and reverse engineering technology

are the most well known data development methods that are used to provide input to AM systems. Other decision support systems, tools and techniques to support AM that have been explored include part orientation algorithms and AM system selection tools. Most of these systems utilise various expert systems technology to support the decision making process.

3. To identify a suitable structure and format that could guide the development of a tool to support industrial designers to develop improved product design for AM.

A decision was made to apply a “software rapid prototyping” approach to develop the design aid tool for AM. The starting point for this was the categorisation of 106 AM design features that were gathered and grouped into a taxonomy that would form the basis of a design feature database. Several iterations of the taxonomy were proposed before a satisfactory classification was achieved (refer Chapter Five). The final taxonomy was developed based on four reasons of AM utilisation. The taxonomy was developed as a result of interview studies and literature reviews undertaken during the earlier stages of the research. The taxonomy categorised 106 AM enabled features under four groups of reasons for AM utilisations namely user fit requirements, product functionality improvement, consolidation requirements and aesthetic and form requirements. These four groups formed the top level of the proposed taxonomy and were further expanded to include thirteen sub categories in the second level of taxons. The taxonomy was found relevant and useful (refer Chapter Five).

4. To recommend and test a tool or approach that could support industrial designers to develop improved product design for AM.

The design support tool has been implemented within an Microsoft Access database known as the DfAM design feature database (refer Chapter Six). A “rapid prototyping” software approach was utilised where a “beta” version of the tool was developed firstly to enable user testing and validation of the system. A series of forms were created to enable designers to search or browse through the feature categories. The design feature database enables industrial designers to visualise

and gather design feature information from examples in the database that could be incorporated into their own design work.

5. To test and validate the DfAM feature database.

User trials were conducted to obtain feedback about the tool's effectiveness, usability and its relevancy. Two sets of user trials were conducted using student designers to compare product design for conventional method and for AM with and without using the DfAM feature database respectively. The validation of the tool was conducted with a group of four postgraduate students. Results from the trials showed the DfAM was an effective tool to aid in designing for AM. The questionnaire feedback result shows that the student designers were positive in terms of the tool's effectiveness and usability to provide inspiration to improve their product design.

8.2 Research Questions Answered

The research questions that were formulated for this research and their answers are now discussed.

Q1: What are the challenges to generate product design for AM?

In total, seven challenges were associated with designing for AM. The primary challenges to generating product design for AM were noted as being:

1. Difficulties in translating desired design features into CAD geometry due to the increase in part complexity.
2. Time consuming design because of the need to understand AM capabilities, the type of AM systems available and the availability of suitable materials to meet mechanical and physical properties. This was due to the current absence of tools to support or guide designers.
3. To meet the requirement that AM is only suitable for low volume production.
4. AM product design has to compromise with limited product colour selection options.

5. Limited types of material properties which could result in poor mechanical performance of the product.
6. Difficulties in constructing the internal structure of parts so as to accommodate other components and parts such as circuit boards etc.
7. Constraints on the CAD capabilities of the designer and on not having had the opportunity to experience AM product development practically.

Q2: What are the reasons for designing AM parts and products?

Based on the findings that were presented and explained in Chapter Four, the key reasons identified for designing AM parts and products were noted as being:

1. User fit requirements – Product customised to accommodate individual user requirements.
2. Product Functionality Improvement – To add value by improving product functionality.
3. Consolidation requirement - To combine various parts, or to combine its functions or to combine the part materials.
4. Aesthetics or form requirements – To add value by improving product appearance.

Q3: What are the methods currently employed by professional designers to design and develop parts or products with AM?

Chapter Four has shown that professional designers uses reverse engineering techniques and later post process the data and edit within a CAD system to enable fast development of parts and products. Highly amorphous product forms such as the golf club grip may be digitised with RE technologies to produce CAD geometries that would otherwise be difficult to achieve using conventional software packages and strategies. From the design point of view, it is found that one of the main challenges that can be associated with AM is the lack of a specific design aid tool and cumulative design knowledge to support the design for AM.

Q4: What information should be presented to industrial designers to enable improved generation of product design that are suited to production by AM?

Through a series of semi-structured interviews with professional designers that were conducted and explained in Chapter Four, this research has attempted to gain insight into designers' thought processes when utilising AM. It has been identified what AM enabled design features they have been able to create within their designed for AM products. Detailed observation of the products and parts revealed a number of features that are only possible with AM. The products shows creative design feature aspects such as aesthetical features, weight reduction features, reduced number of parts and complex geometric forms that could be embedded into the product design. Examples of specific features used are such as variable wall thickness, hollow structure, undercut geometries etc. For this reason, the information that needs to be provided to industrial designers to design for AM is visual information about potentially useful design features to be added to their product design.

Q5: How can the information about the AM design features be structured to enable the creation of a DfAM tool?

Chapter Five explores the development of the AM taxonomy by identifying and organising 106 AM design features for easy retrieval and assistance for product design and as a method to aid in the development of the final design tool. This was because innovative design features were seen as an embodiment of designers' tacit knowledge about designing for AM. Organising these features into a systematic taxonomy was seen as a first step to making this knowledge accessible to other designers.

Q6: What is the optimum way of presenting AM design knowledge to industrial designers?

The most effective way of achieving this is to give designers a methodological approach to follow when considering designing for AM. Therefore, it was decided that this research should identify a suitable Design for Additive Manufacturing (DfAM) 'software prototype' tool that will assist industrial designers in identifying the feasibility of AM for a given part or product production and also in assisting product design for AM based on reason of AM utilisation. To expose designers to the concept of design freedom that AM enables, it was decided to develop the tool in a form of a database that provided visual examples of AM enabled features that could be imparted to a given product design. The DfAM feature database that has been developed in this research was able to provide inspiration to industrial designers for creative and complex geometrical design features enabled by AM that could be applied to their product design. The tool also provided examples of design features that could be used to obtain specific functionality with regards to AM capability. Furthermore, the tool provided inspiration for design features that support the concept of design for assembly by giving examples of part reduction methods that could be applied utilising AM.

8.3 Contribution to Knowledge

It is believed that this research has contributed towards the advancement of original knowledge that is relevant and applicable particularly in the product development process for AM products or parts. The key original contributions claimed for this research are as follow:

1. The research investigated and listed the main challenges and issues that are faced by industrial designers when developing product design for AM, and confirmed that there was a need to develop a tool to aid them in this process.
2. The research identified that there are four main reasons for AM utilisation, namely user fit requirements, product functionality improvement, consolidation requirements and aesthetics or form requirements.

3. A taxonomy was developed based on four reasons of AM utilisation and was further expanded into thirteen sub categories of application that contains 106 AM enabled design features within it. The taxonomy is one of the most important contributions as it could be a useful aid to the development of other DfAM tools.
4. This research has shown that the information about AM enabled design features that has been collated in the taxonomy can be usefully presented to industrial designers in the form of a feature database.
5. Visual information on AM enabled features has been shown to support industrial designers in product design for AM.

A list of papers derived from this research is given in Appendix H.

8.4 Recommendations for Future Work

Whilst this research has achieved the research aims and objectives, there are several recommendations that could be implemented to take the research further. These are as follows:

1. To make the database publically available on the Internet. However, prior permission from the image owners would have to be obtained. Work on this process is already in progress.
2. To include more AM enabled design features within the database. Through a central DfAM user group, users could upload their own features into specific categories in the database.
3. To add the ability for 3D viewing of features with the database.

8.5 Overall Conclusion

In summary, it may be concluded that this research project has been successful in addressing all of the objectives that were identified at its outset. The literature review in Chapter Three shows that AM is becoming more and more important in today's competitive product markets and needs to be supported by a tool in product design for AM. From the user trial results, it is clear that the proposed tool would be an effective method to support design for AM, particularly from an educational perspective. The tool was found to be beneficial to student designers to take advantage of the design freedom offered by AM in order to produce better product design. As AM becomes more widely used, it is anticipated that new design features will emerge that could be included in future versions of the database so that it will remain a rich source of inspirational information for tomorrow's industrial designers.

REFERENCES:

- AAMODT, A. & PLAZA, E. (1994) Case Base Reasoning: Foundational Issues, Methodological Variations, and System Approaches. *AICom—Artificial Intelligence Communications*. 1 ed.
- AMOROSO, E. G. (1994) *Fundamentals of computer security technology*, Englewood Cliffs, N.J., PTR Prentice Hall.
- ANTON, G. & RAFAEL, V. (2006) A Concept of Manufacturing System Enabling the Creation of Custom Fit Products. *10th International Research Trends in the Development of Machinery and Associated Technology*.
- BAGCI, E. (2009) Reverse engineering applications for recovery of broken or worn parts and re-manufacturing: Three case studies. *Advances in Engineering Software*, 40, 407-418.
- BAK, D. (2003) Rapid prototyping or rapid production? 3D printing processes move industry towards the latter. *Assembly Automation*, 23, 340-345.
- BAXTER, D., GAO, J., CASE, K., HARDING, J., YOUNG, B., COCHRANE, S. & DANI, S. (2008) A framework to integrate design knowledge reuse and requirements management in engineering design. *ICMR2005: Third International Conference on Manufacturing Research*, 24, 585-593.
- BAXTER, M. (1995) *Product design: a practical guide to systematic methods of new product development*, London; New York, Chapman & Hall.
- BIBB, R. & EGGBEER, D. (2006) Rapid manufacture of removable partial denture frameworks. *Rapid Prototyping Journal*, 12, 95-99.
- BIBB, R., TAHA, Z., BROWN, R. & WRIGHT, D. (1999) Development of a rapid prototyping design advice system. *Journal of Intelligent Manufacturing*, 10, 331-339.
- BONNARDEL, N. & MARMÈCHE, E. (2005) Towards supporting evocation processes in creative design: A cognitive approach. *Computer support for creativity*, 63, 422-435.
- BOYLE, J. M. (1989) Interactive engineering systems design: A study for artificial intelligence applications. *Artificial Intelligence in Engineering*, 4, 58-69.
- BRANDT, S. C., MORBACH, J., MIATIDIS, M., THEIBEN, M., JARKE, M. & MARQUARDT, W. (2008) An ontology-based approach to knowledge management in design processes. *Process Systems Engineering: Contributions on the State-of-the-Art - Selected extended Papers from ESCAPE '16/PSE 2006.*, 32, 320-342.
- BRUNETTI, G. & GOLOB, B. (2000) A feature-based approach towards an integrated product model including conceptual design information. *Computer-Aided Design*, 32, 877-887.
- BÜYÜKÖZKAN, G., DERELİ, T. & BAYKASOĞLU, A. (2004) A survey on the methods and tools of concurrent new product development and agile manufacturing. *Journal of Intelligent Manufacturing*, 15, 731-751.

- BURTON, M. J. (2005) Phd Thesis: Design for rapid manufacture: Developing an appropriate knowledge transfer tool for industrial designers. *Faculty of Social Sciences & Humanities, Department of Design & Technology*. Loughborough, Loughborough University.
- BYUN, H. S. & LEE, K. H. (2005) A decision support system for the selection of a rapid prototyping process using the modified TOPSIS method. *The International Journal of Advanced Manufacturing Technology*, 26, 1338-1347.
- CAMPBELL, R. I. & BERNIE, M. R. N. (1996) Creating a database of rapid prototyping system capabilities. *12th International Conference on Computer Aided Production Engineering*, 61, 163-167.
- CARAYANNIS, E. & COLEMAN, J. (2005) Creative system design methodologies: the case of complex technical systems. *Technovation*, 25, 831-840.
- CARKETT, R. (2004) 'He's different, he's got 'Star Trek' vision': supporting the expertise of conceptual design engineers. *Expertise in Design*, 25, 459-475. Carnegie Mellon University.
- CHANG, X., SAHIN, A. & TERPENNY, J. (2008) An ontology-based support for product conceptual design. *Robotics and Computer-Integrated Manufacturing*, 24, 755-762.
- CHEN, Y., HUI, A. & DU, R. (1995) Fuzzy expert system machining operations. *Int. Journal Machining Tools Manufacturing*, 35, 1605-1621.
- CHENG, W., FUH, J. Y. H., NEE, A. Y. C., WONG, Y. S., LOH, H. T. & MIYAZAWA, T. (1995) Multi-objective optimization of part building orientation in stereolithography. *Rapid Prototyping Journal*, 1, 12-23.
- CHOCKALINGAM, K., JAWAHAR, N., CHANDRASEKAR, U. & RAMANATHAN, K. N. (2008) Establishment of process model for part strength in stereolithography. *Journal of Materials Processing Technology*, 208, 348-365.
- CHUA, C. K. & LEONG, K. F. (1997) *Rapid prototyping: principles & applications in manufacturing*, New York, J. Wiley.
- CHUA, C. K., LEONG, K. F. & LIM, C. S. (2010) *Rapid prototyping: principles and applications*, Singapore; Hackensack, NJ, World Scientific.
- CLARKSON, J. & ECKERT, C. (2005) *Design process improvement: a review of current practice*, London, Springer.
- COMPANY, P., CONTERO, M., VARLEY, P., ALEIXOS, N. & NAYA, F. (2009) Computer-aided sketching as a tool to promote innovation in the new product development process. *Computers in Industry*, 60, 592-603.
- CRILLY, N., GOOD, D., MATRAVERS, D. & CLARKSON, P. J. (2008) Design as communication: exploring the validity and utility of relating intention to interpretation. *Design Studies*, 29, 425-457.
- CROSS, N. and ROOZENBURG, N (1992) Modelling the Design Process in Engineering and in Architecture, *Journal of Engineering Design*, Vol. 3, No.4
- CROSS, N. (1989) *Engineering design methods*, Chichester (England), New York, Wiley.
- CROSS, N. (1990) The nature and nurture of design ability. *Design Studies*, 11, 127-140.

- CROSS, N. (2006) *Designerly ways of knowing*, London, Springer.
- CROSS, N. (2008) *Engineering design methods: strategies for product design*, Chichester, Wiley.
- CUNNINGHAM, I. A. D., J (1988) Designing with features: the origin of features. IN ASME Ed. *Proc. Computers in Engineering Conference*. San Francisco, USA
- DAHL, D. W., CHATTOPADHYAY, A. & GORN, G. J. (2001) The importance of visualisation in concept design. *Design Studies*, 22, 5-26.
- DERR, R. L. (1973) *A taxonomy of social purposes of public schools: a handbook*, New York, McKay.
- DÍAZ-AGUDO, B., GONZÁLEZ-CALERO, P. A., RECIO-GARCÍA, J. A. & SÁNCHEZ-RUIZ-GRANADOS, A. A. (2007) Building CBR systems with jCOLIBRI. *Special issue on Experimental Software and Toolkits*, 69, 68-75.
- DIETER, G. E. & SCHMIDT, L. C. (2009) *Engineering design*, Boston, McGraw-Hill Higher Education.
- DIMOV, S. S., PHAM, D. T., LACAN, F. & DOTCHEV, K. D. (2001) Rapid tooling applications of the selective laser sintering process. *Assembly Automation*, 21, 296-302.
- DORST, K. & DIJKHUIS, J. (1995) Comparing paradigms for describing design activity. *Analysing Design Activity*, 16, 261-274.
- DOUNIS, A. I., SANTAMOURIS, M. J., LEFAS, C. C. & ARGIRIOU, A. (1995) Design of a fuzzy set environment comfort system. *Energy and Buildings*, 22, 81-87.
- DU PLESSI, P. (2008) A Functional Application of RM in A Military Environment. *Proceedings of the TCT 2008 Rapid Manufacturing Conference*. Coventry, UK.
- DUFF, J. M. & ROSS, W. A. (1995) *Freehand sketching for engineering design*, Boston, PWS Pub. Co.
- EDER, W. E. & HOSNEDL, S. (2008) *Design engineering: a manual for enhanced creativity*, Boca Raton, CRC Press.
- EVANS, M. (1992) Model or Prototype which, when and why? *IDATER 1992*. Loughborough University.
- FERGUSON, E. S. (1992) *Engineering and the mind's eye*, Cambridge, Mass., MIT Press.
- FONTANA M., G. F., MEIRANA M., (1999) A freeform feature taxonomy. *Computer Graphics Forum*
- FRANK, D. & FADEL, G. (1994) Expert system based selection of the preferred direction of build for rapid prototyping. *Journal of Intelligent Manufacturing*, 6, 334-339.
- FRENCH, M. J. (1999) *Conceptual Design for Engineers*. 3RD Edition, Springer, ISBN, 1852330279

- FU, Q. Y., CHUI, Y. P. & HELANDER, M. G. (2006) Knowledge identification and management in product design. *Journal of Knowledge Management*, 10, 50-63.
- GARCIA, C., GONZALEZ, D., GARCIA, M.A., FELGUEROSO-SAN JULIAN, I., POZO AYUSO, D.F. AND QUEIPO, P. (2008) Personalised Tools Manufactured by Rapid Manufacturing for Medical Surgery - A Success Case of Spanish SME. *Proceedings of the International Conference on Additive technologies (iCAT)*. Slovenia.
- GERO, J. S. (1996) Creativity, emergence and evolution in design. *Knowledge-Based Systems*, 9, 435-448.
- GERSHENSON, J. A. S., L. (1999) Taxonomy for design requirements from corporate customers. *Research in Engineering Design*, 11, 103-105.
- GIBSON, I., ROSEN, D. W. & STUCKER, B. (2010) *Additive manufacturing technologies: rapid prototyping to direct digital manufacturing*, New York; London, Springer.
- GOLDBERG, D. E. (1989) *Genetic algorithms in search, optimization, and machine learning*, Reading, Mass., Addison-Wesley Pub. Co.
- GONNET, S., HENNING, G. & LEONE, H. (2007) A model for capturing and representing the engineering design process. *Expert Systems with Applications*, 33, 881-902.
- GOPAKUMAR, S. (2004) RP in medicine: A case study in cranial reconstructive surgery. *Rapid Prototyping Journal*, 10, 207-211.
- GOUVINHAS, R. P. (1998) *Design methods for production machinery companies*, Cranfield University.
- GRAHAM, I. J., KEITH, C. & WOOD, R. I. (2001) Genetic algorithms in computer aided design. *Journal of Materials Processing Technology*, 117, 216-221.
- GUPTA, V. & MURTHY, P. N. (1980) *An introduction to engineering design method*, New Delhi, Tata McGraw-Hill Pub.
- HAGUE, R., CAMPBELL, I. & DICKENS, P. (2003) Implications on design of rapid manufacturing. *Proceedings of the Institution of Mechanical Engineers, Part C: Journal of Mechanical Engineering Science*, 217, 25-30.
- HAGUE, R., MANSOUR, S. & SALEH, N. (2003) Design opportunities with rapid manufacturing. *Assembly Automation*, 23, 346-356.
- HAGUE, R., MANSOUR, S. & SALEH, N. (2004) Material and design considerations for rapid manufacturing. *International Journal of Production Research*, 42, 4691 - 4708.
- HALL, S. (2011) World's Largest Passenger Jet Lands At Miami International Airport. *Aviation Online Magazine*. United States of America.
- HANSMAN, S. & HUNT, R. (2005) A taxonomy of network and computer attacks. *Computers & Security*, 24, 31-43.
- HEYLIGHEN, A. & NEUCKERMANS, H. (2011) A case base of case based design tools for architecture. *Computer Aided Design*, 33, 1111 - 1122.

- HICKS, B. J., CULLEY, S. J., ALLEN, R. D. & MULLINEUX, G. (2002) A framework for the requirements of capturing, storing and reusing information and knowledge in engineering design. *International Journal of Information Management*, 22, 263-280.
- HIEU, L. C., ZLATOV, N., SLOTEN, J. V., BOHEZ, E., KHANH, L., BINH, P. H., ORIS, P. & TOSHEV, Y. (2005) Medical rapid prototyping applications and methods. *Assembly Automation*, 25, 284-292.
- HOLMES, W. P., AZAM, M. A. & HILLS, P. C. (1995) A preliminary study of the relationship between industrial design and engineering design. *Proceedings of the 1st conference on Designing interactive systems: processes, practices, methods, & techniques*. Ann Arbor, Michigan, United States, ACM.
- HOLMQUIST, L. E. (2005) Practice - DESIGN - Prototyping: Generating Ideas or Cargo Cult Designs? *Interactions*, 12, 48.
- HONGJUN, L., ZITIAN, F., NAIYU, H. & XUANPU, D. (2003) A note on rapid manufacturing process of metallic parts based on SLS plastic prototype. *Journal of Materials Processing Technology*, 142, 710-713.
- HOPKINSON, N. & DICKENS, P. (2000) A comparison between stereolithography and aluminium injection moulding tooling. *Rapid Prototyping Journal*, 6, 253-258.
- HOPKINSON, N. & DICKENS, P. (2001) Rapid prototyping for direct manufacture. *Rapid Prototyping Journal*, 7, 197-202.
- HOPKINSON, N., HAGUE, R. J. M. & DICKENS, P. (2006) *Rapid manufacturing: an industrial revolution for the digital age*, Chichester, England, John Wiley.
- HOWARD, J. D. (1997) An analysis of security incidents on the internet, Carnegie Mellon University, Phd Thesis.
- HOWARD, T. J., CULLEY, S. J. & DEKONINCK, E. (2008) Describing the creative design process by the integration of engineering design and cognitive psychology literature. *Design Studies*, 29, 160-180.
- HSU, W. & LIU, B. (2000) Conceptual design: issues and challenges. *Computer-Aided Design*, 32, 849-850.
- IMRE, H. (2000) CONCEPTUAL DESIGN: INSIDE AND OUTSIDE. *Proceedings of the 2nd International Seminar and Workshop on Engineering Design in Integrated Product*, Zielona Góra: Technical University of Zielona Góra.
- JAMSHIDI, M. (1997) *Applications of fuzzy logic: towards high machine intelligence quotient systems*, Upper Saddle River, N.J., Prentice Hall PTR.
- JEFFREY, C. (1982) *An introduction to plant taxonomy*, Cambridge [Cambridgeshire]; New York, Cambridge University Press.
- JOHAN, J. B., WOUTER, S., IMRE, H. T. & ALEX, F. L. (2009) Using Physical Models In Design. Department of Design Engineering, Delft University of Technology, The Netherlands
- JONES, K. G. & CAMPBELL, R. I. (1997) Rapid Prototyping Decision Support System. *Proceedings Fast Freeform Fabrication Symposium*. University of Texas at Austin.

- JONSON, B. (2005) Design ideation: the conceptual sketch in the digital age. *Design Studies*, 26, 613-624.
- KEMP, B. & BUCKNER, K. (1999) A taxonomy of design guidance for hypermedia design. *Interacting with Computers*, 12, 143-160.
- KEMP, M. (2009) Review: The Art Instinct by Denis Dutton. *The New Scientist*, 201, 44-45.
- KING, D. & TANSEY, T. (2003) Rapid tooling: selective laser sintering injection tooling. *Journal of Materials Processing Technology*, 132, 42-48.
- KOUFTEROS, X. & MARCOULIDES, G. A. (2006) Product development practices and performance: A structural equation modeling-based multi-group analysis. *International Journal of Production Economics*, 103, 286-307.
- KOUHI, E., MASOOD, S. & MORSI, Y. (2008) Design and fabrication of reconstructive mandibular models using fused deposition modeling. *Assembly Automation*, 28, 246-254.
- KRSUL, I. (1998) Software vulnerability analysis. Purdue University.
- KRUF, W., VAN DE VORST, B., MAALDERINK, H., KAMPERMAN, N., PHAM, D. T., ELDUKHRI, E. E. & SOROKA, A. J. (2006) Design for Rapid Manufacturing functional SLS parts. *Intelligent Production Machines and Systems*. Oxford, Elsevier Science Ltd.
- KRUTH, J. P., LEVY, G., KLOCKE, F. & CHILDS, T. H. C. (2007) Consolidation phenomena in laser and powder-bed based layered manufacturing. *CIRP Annals - Manufacturing Technology*, 56, 730-759.
- KRUTH, J. P., WANG, X., LAOUI, T. & FROYEN, L. (2003) Lasers and materials in selective laser sintering. *Assembly Automation*, 23, 357-371.
- KURTOGLU, T., CAMPBELL, M. I. & LINSEY, J. S. (2009) An experimental study on the effects of a computational design tool on concept generation. *Design Studies*, 30, 676-703.
- LAN, H., DING, Y. & HONG, J. (2005) Decision support system for rapid prototyping process selection through integration of fuzzy synthetic evaluation and an expert system. *International Journal of Production Research*, 43, 169-194.
- LAN, P. T., CHOU, S. Y., CHEN, L. L. & GEMMILL, D. (1997) Determining fabrication orientation for rapid prototyping with stereolithography apparatus. *Computer Aided Design*, 29, 53-62.
- LAWSON, B. (2006) *How designers think : the design process demystified*, Oxford, Architectural Press.
- LEE, K. (1999) *Principles of CAD/CAM/CAE systems*, Reading, Mass., Addison-Wesley.
- LEVY, G. N., SCHINDEL, R. & KRUTH, J. P. (2003) RAPID MANUFACTURING AND RAPID TOOLING WITH LAYER MANUFACTURING (LM) TECHNOLOGIES, STATE OF THE ART AND FUTURE PERSPECTIVES. *CIRP Annals - Manufacturing Technology*, 52, 589-609.
- LI, C. H., SONG, W. & PARK, S. C. (2009) An automatically constructed thesaurus for neural network based document categorization. *Expert Systems with Applications*, 36, 10969-10975.

- LIU, Y.T. (2000) Creativity or novelty?: Cognitive-computational versus social-cultural. *Design Studies*, 21, 261-276.
- LORENZ, C. (1990) *The design dimension: the new competitive weapon for product strategy and global marketing*, Oxford, UK; Cambridge, Mass., USA, B. Blackwell.
- LOUGH, D. L. (2001) A taxonomy of computer attacks with applications to wireless networks. Virginia Polytechnic Institute and State University.
- LUCIE-SMITH, E. (2004) *The Thames & Hudson dictionary of art terms*, New York, N.Y., Thames & Hudson.
- M.BISHOP (1999) Vulnerabilities analysis. *International symposium on recent advances in intrusion detection*.
- MAHER, M. L., BALACHANDRAN, M. & ZHANG, D. M. (1995) *Case-based reasoning in design*, Mahwah, N.J., Lawrence Erlbaum Associates.
- MAIDIN S., Campbell. R. I. (2009) Rapid Manufacturing: What are the Issues of Student Designers? *10th Annual International Conference On Innovative Rapid Product Development, (RAPDASA 2009)* East London, Mpekwini Beach Resort.
- MARCH, L. (1984) *Development in Design Methodology*, John Wiley & Sons.
- MARION, T. J. & SIMPSON, T. W. (2009) New product development practice application to an early-stage firm: the case of the PaperPro® StackMaster(TM). *Design Studies*, 30, 561-587.
- MASOOD, S. H. & SOO, A. (2002) A rule based expert system for rapid prototyping system selection. *Robotics and Computer-Integrated Manufacturing*, 18, 267-274.
- MCGARRY, K., WERMTER, S. & MACINTYRE, J. (1999) Hybrid neural systems: from simple coupling to fully integrated neural networks. *Neural Computing Surveys* 2.
- MCMAHON, C. & BROWNE, J. (1998) *CADCAM: Principles, Practice and Manufacturing Management*, Addison-Wesley.
- MENEZES, A. & LAWSON, B. (2006) How designers perceive sketches. *Design Studies*, 27, 571-585.
- MITCHELL, M. & FORREST, S. (1994) Genetic Algorithms and Artificial Life. *Artificial Life*, 1, 267-289.
- MOORE, C. J. & LEHANE, M. S. (1999) Development of a case representation strategy for a bridge design case base. *Engineering Structures*, 21, 219-231.
- MORIDIS, C. N. & ECONOMIDES, A. A. (2009) Prediction of student's mood during an online test using formula-based and neural network-based method. *Computers & Education*,
- MORRIS, L. J. & STAUFFER, L. A. (1994) A design taxonomy for eliciting customer requirements. *Computers & Industrial Engineering*, 27, 557-560.

- MOULIANITIS, V. C., ASPRAGATHOS, N. A. & DENTSORAS, A. J. (2004) A model for concept evaluation in design--an application to mechatronics design of robot grippers. *Mechatronics*, 14, 599-622.
- MUNGUIA, J., CIURANA, J. D. & RIBA, C. (2008) Pursuing successful rapid manufacturing: a users' best-practices approach. *Rapid Prototyping Journal*, 14, 173-179.
- NG, P., LEE, P. S. V. & GOH, J. C. H. (2002) Prosthetic sockets fabrication using rapid prototyping technology. *Rapid Prototyping Journal*, 8, 53-59.
- NIGAN, B. (2004) Investigating Design: A Review of Forty Years of Design Research. *Design Issues: Volume 20, Number 1 Winter 2004*.
- NYIRENDA, P. J. & BRONSVOORT, W. F. (2009) A framework for extendable freeform surface feature modelling. *Computers in Industry*, 60, 35-47.
- NYIRENDA, P. J., BRONSVOORT, W. F., LANGERAK, T. R., SONG, Y. & VERGEEST, J. S. M. (2005) A Generic Taxonomy for Defining Freeform Feature Classes. *Computer-Aided Design & Applications*, 2, 497-506.
- OBOT, O. U. & UZOKA, F.-M. E. (2009) A framework for application of neuro-case-rule base hybridization in medical diagnosis. *Applied Soft Computing*, 9, 245-253.
- OLOFSSON, E., SJÖLÉN, K. & UMEÅ UNIVERSITET, D. (2005) *Design sketching*, [Umeå, Sweden], KEEOS Design Books.
- OSTERGAARD K.J., S. J. D. (2009) Development of a systematic classification and taxonomy of collaborative design activities. *Journal of Engineering Design*, 20, 57-81.
- PAGE, D., KOSCHAN, A., VOISIN, S., ALI, N. & ABIDI, M. (2005) 3D CAD model generation of mechanical parts using coded-pattern projection and laser triangulation systems. *Assembly Automation*, 25, 230-238.
- PAHL, G. & BEITZ, W. (1996) *Engineering design: a systematic approach*, London; New York, Springer.
- PANDEY, P. M., THRIMURTULLU, K. & REDDY, N. V. (2004) Optimal part deposition orientation in FDM using a multi-criterion genetic algorithm. *Int. J. Prod. Res.*, 42, 4069-4089.
- PANDEY, P. M., VENKATA REDDY, N. & DHANDE, S. G. (2007) Part deposition orientation studies in layered manufacturing. *ICAMT 2004 (Malaysia) & CCAMT 2004 (India) Special Issue*, 185, 125-131.
- PEDGLEY, O. (2007) Capturing and analysing own design activity. *Design Studies*, 28, 463-483.
- PEI, E. (2009) Building A Common Ground: Using Colab to support collaboration between industrial designers & engineering designers in new product development. . *Design & Technology*. Loughborough, Loughborough University.
- PEÑA-REYES, C. A. & SIPPER, M. (2000) Evolutionary computation in medicine: an overview. *Artificial Intelligence in Medicine*, 19, 1-23.

- PERNOT, J. P., FALCIDIENO, B., GIANNINI, F. & LÉON, J. C. (2008) Incorporating free-form features in aesthetic and engineering product design: State-of-the-art report. *Computers in Industry*, 59, 626-637.
- PHAM, D. T. A. D., S.S (2003) Rapid prototyping and rapid tooling - the key enablers for rapid manufacturing.
- PHILLIPSON, D. (1997) Rapid Prototyping Machine Selection Programme. *Proceedings of the 6th European Conference on Rapid Prototyping and Tooling*.
- PIPES, A. (2007) *Drawing for designers*, London, Laurence King.
- POTTER, S., DARLINGTON, M. J., CULLEY, S. J. & CHAWDHRY, P. K. (2001) Design synthesis knowledge and inductive machine learning. *Artif. Intell. Eng. Des. Anal. Manuf.*, 15, 233-249.
- PRATT, M. J. (1988) A taxonomy of form features for solid modeling. *Geometric Modeling for CAD Applications*.
- PUGH, S. (1991) *Total design: integrated methods for successful product engineering*, Wokingham, England; Reading, Mass., Addison-Wesley Pub. Co.
- PUGH, S., CLAUSING, D. & ANDRADE, R. (1996) *Creating innovative products using total design : the living legacy of Stuart Pugh*, Reading, Mass., Addison-Wesley Pub. Co.
- RAJAN, K., RAMALINGAM, V., GANESAN, M., PALANIVEL, S. & PALANIAPPAN, B. (2009) Automatic classification of Tamil documents using vector space model and artificial neural network. *Expert Systems with Applications*, 36, 10914-10918.
- RAO, R. V. & PADMANABHAN, K. K. (2007) Rapid prototyping process selection using graph theory and matrix approach. *Journal of Materials Processing Technology*, 194, 81-88.
- RENNER, G. & EKÁRT, A. (2003) Genetic algorithms in computer aided design. *Computer-Aided Design*, 35, 709-726.
- REZAEIAN, J., JAVADIAN, N., TAVAKKOLI-MOGHADDAM, R. & JOLAI, F. (2011) A hybrid approach based on the genetic algorithm and neural network to design an incremental cellular manufacturing system. *Applied Soft Computing*, 11, 4195-4202.
- ROCHUS, P., PLESSERIA, J. Y., VAN ELSSEN, M., KRUTH, J. P., CARRUS, R. & DORMAL, T. (2007) New applications of rapid prototyping and rapid manufacturing (RP/RM) technologies for space instrumentation. *Bringing Space Closer to People, Selected Proceedings of the 57th IAF Congress, Valencia, Spain, 2-6 October, 2006*, 61, 352-359.
- ROOZENBURG, N. F. M. & EEKELS, J. (1995) *Product design: fundamentals and methods*, Chichester; New York, Wiley.
- RUFFO, M., TUCK, C. & HAGUE, R. (2007) Make or buy analysis for rapid manufacturing. *Rapid Prototyping Journal*, 13, 23-29.
- SALEH, N., HOPKINSON, N., HAGUE, R. J. M. & WISE, S. (2004) Effects of electroplating on the mechanical properties of stereolithography and laser sintered parts. *Rapid Prototyping Journal*, 10, 305-315.
- SALOMONS, O. W., VAN HOUTEN, F. J. A. M. & KALS, H. J. J. (1993) Review of research in feature-based design. *Journal of Manufacturing Systems*, 12, 113-132.

- SANTOS, E. C., SHIOMI, M., OSAKADA, K. & LAOUI, T. (2006) Rapid manufacturing of metal components by laser forming. *International Journal of Machine Tools and Manufacture*, 46, 1459-1468.
- SARIDAKIS, K. M. & DENTSORAS, A. J. (2008) Soft computing in engineering design – A review. *Advanced Engineering Informatics*, 22, 202-221.
- SCHÖN, D. A. (1983) *The reflective practitioner: how professionals think in action*, New York, Basic Books.
- SCHOONMAKER, S. J. (2003) *The CAD guidebook : a basic manual for understanding and improving computer-aided design*, New York, Marcel Dekker.
- SCOTT, M. J. & ANTONSSON, E. K. (1998) Preliminary vehicle structure design: an industrial application of imprecision in engineering design. *Proceedings of DETC'98 ASME Design Engineering Technical Conferences*. Atlanta, Georgia.
- SHAH, J. J. & MÄNTYLÄ, M. (1995) *Parametric and feature-based CAD/CAM : concepts, techniques, and applications*, New York, Wiley.
- SHAH, J. J. (1998) Experimental investigation of collaborative techniques for progressive idea generation. *Design engineering technical conferences (DETC1998)*. Atlanta.
- SHETTY, D. (2002) *Design for product success*, Dearborn, MI, Society of Manufacturing Engineers.
- SHNEIDERMAN, B. (1992) *Designing the user interface: Strategies for effective human-computer interaction*, Reading, Mass., Addison-Wesley.
- SHU-HSIEN, L. (2005) Expert system methodologies and applications - a decade review from 1995 to 2004. *Expert Systems with Applications*, 28, 93-103.
- SINGARE, S., LIAN, Q., WANG, W. P., WANG, J., LIU, Y., LI, D. & LU, B. (2009) Rapid prototyping assisted surgery planning and custom implant design. *Rapid Prototyping Journal*, 15, 19-23.
- SINGARE, S., YAXIONG, L., DICHEN, L., BINGHENG, L., SANHU, H. & GANG, L. (2006) Fabrication of customised maxillo-facial prosthesis using computer-aided design and rapid prototyping techniques. *Rapid Prototyping Journal*, 12, 206-213.
- SONG, J. L., LI, Y. T., DENG, Q. L. & HU, D. J. (2007) Rapid prototyping manufacturing of silica sand patterns based on selective laser sintering. *3rd International Conference on Advanced Forming and Die Manufacturing Technology*, 187-188, 614-618.
- STOLL, H. W. (1999) *Product design methods and practices*, New York, Marcel Dekker.
- SUTHERLAND, I. E. & LINCOLN, L. (1963) *Sketchpad : a man-machine graphical communication system*, Lexington, Mass.; Springfield, Va., Massachusetts Institute of Technology, Lincoln Laboratory ; Reproduced by National Technical Information Service.
- TANG, J. C. (1991) Findings from observational studies of collaborative work. *International Journal of Man-Machine Studies*, 34, 143-160.
- TAY, F. E. H. & GU, J. (2002) Product modeling for conceptual design support. *Computers in Industry*, 48, 143-155.

- TJALVE, E., ANDREASEN, M. M. & FRACKMANN SCHMIDT, F. (1979) *Engineering graphic modelling: a workbook for design engineers*, London; Boston, Newnes-Butterworths.
- TOVEY, M. (1989) Drawing and CAD in industrial design. *Design Studies*, 10, 24-39.
- TOVEY, M., PORTER, S. & NEWMAN, R. (2003) Sketching, concept development and automotive design. *Design Studies*, 24, 135-153.
- TRAINI, T., MANGANO, C., SAMMONS, R. L., MANGANO, F., MACCHI, A. & PIATTELLI, A. (2008) Direct laser metal sintering as a new approach to fabrication of an isoelastic functionally graded material for manufacture of porous titanium dental implants. *Dental Materials*, 24, 1525-1533.
- TRUSCOTT, M., BEER, D. D., VICATOS, G., HOSKING, K., BARNARD, L., BOOYSEN, G. & CAMPBELL, R. I. (2007) Using RP to promote collaborative design of customised medical implants. *Rapid Prototyping Journal*, 13, 107-114.
- TSENG, T.L. & HUANG, C.C. (2008) Design support systems: A case study of modular design of the set-top box from design knowledge externalization perspective. *Decision Support Systems*, 44, 909-924.
- ULF, L. & ERLAND, J. (1997) How to Systematically Classify Computer Security Intrusions. *Proceedings of the 1997 IEEE Symposium on Security and Privacy*. IEEE Computer Society.
- ULLMAN, D. A. D. A., B., (1995) Taxonomy for classifying engineering decision problems and support systems. *Artificial Intelligence for Engineering Design, Analysis and Manufacturing*, 9 427-38.
- ULLMAN, D. G. (1992) A taxonomy for mechanical design. *Research in Engineering Design*, 3, 179-189.
- ULLMAN, D. G. (1992) *The mechanical design process*, New York, McGraw-Hill.
- ULRICH, K. T. & EPPINGER, S. D. (2004) *Product design and development*, Boston, McGraw-Hill/Irwin.
- VAN DER LUGT, R. (2005) How sketching can affect the idea generation process in design group meetings. *Design Studies*, 26, 101-122.
- VDI (1987) VDI Design Handbook 2221: Systematic Approach to the design of Technical Systems and Product.
- VERVIS, M. (1994) The Importance of the use of physical engineering models in design. *IDATER94*, . Loughborough University.
- WANG, H.C. & WANG, H.-S. (2005) A hybrid expert system for equipment failure analysis. *Expert Systems with Applications*, 28, 615-622.
- WANG, L., SHEN, W., XIE, H., NEELAMKAVIL, J. & PARDASANI, A. (2002) Collaborative conceptual design—state of the art and future trends. *Computer-Aided Design*, 34, 981-996.
- WEHEBA, G. & SANCHEZ-MARSA, A. (2006) Using response surface methodology to optimize the stereolithography process. *Rapid Prototyping Journal*, 12, 72-77.

- WILLIAMS, J. M., ADEWUNMI, A., SCHEK, R. M., FLANAGAN, C. L., KREBSBACH, P. H., FEINBERG, S. E., HOLLISTER, S. J. & DAS, S. (2005) Bone tissue engineering using polycaprolactone scaffolds fabricated via selective laser sintering. *Biomaterials*, 26, 4817-4827.
- WILSON, E. O. (1992) *The diversity of life*, Cambridge, Mass., Belknap Press of Harvard University Press.
- WOHLEBER, C. (1993) *Straight Up. American Heritage of Invention and Technology*.
- WOHLERS, T. (2008) Wohlers Report 2008, State of the Industry, Annual Worldwide Report. United States Of America, Wohler Associates.
- WOHLERS, T. (2011) Wohler Report 2011 Additive manufacturing and 3D printing state of the industry annual worldwide progress report. United States Of America, Wohler Associates.
- XU, F., WONG, Y. S., LOH, H. T., FUH, J. Y. H. & MIYAZAWA, T. (1997) Optimal orientation with variable slicing in stereolithography. *Rapid Prototyping Journal*, 3, 76-88.
- YADROITSEV, I., THIVILLON, L., BERTRAND, P. & SMUROV, I. (2007) Strategy of manufacturing components with designed internal structure by selective laser melting of metallic powder. *Laser synthesis and processing of advanced materials - E-MRS-P Symposium*, 254, 980-983.
- YANG, M. C. (2005) A study of prototypes, design activity, and design outcome. *Design Studies*, 26, 649-669.
- YANG, Y., LOH, H. T., FUH, J. Y. H. & WONG, Y. S. (2003) Feature extraction and volume decomposition for orthogonal layered manufacturing. *Computer-Aided Design*, 35, 1119-1128.
- YAU, N.J. & YANG, J.B. (1998) Applying case-based reasoning technique to retaining wall selection. *Automation in Construction*, 7, 271-283.
- YE, J. & CAMPBELL, R. I. (2006) Supporting conceptual design with multiple VR based interfaces. *Virtual and Physical Prototyping*, 1, 171-181.
- YE, X., LIU, H., CHEN, L., CHEN, Z., PAN, X. & ZHANG, S. (2008) Reverse innovative design — an integrated product design methodology. *Current State and Future of Product Data Technologies (PDT)*, 40, 812-827.
- YOON, Y., ACREE, A. D. & PETERSON, L. L. (1993) Development of a case-based expert system: Application to a service coordination problem. *Expert Systems with Applications*, 6, 77-85.
- ZHA, X. F., SRIRAM, R. D., FERNANDEZ, M. G. & MISTREE, F. (2008) Knowledge-intensive collaborative decision support for design processes: A hybrid decision support model and agent. *S.I. Advances in Collaborative Engineering: From Concurrent - SI on Collaborative design: New methodologies and technologies*, 59, 905-922.
- ZIEMIAN, C. W. & CRAWN, P. M., III (2001) Computer aided decision support for fused deposition modeling. *Rapid Prototyping Journal*, 7, 138-147.

APPENDIX A
STUDENT DESIGNERS QUESTIONNAIRE SURVEY

Synopsis:

This questionnaire will be used as part of a research study aiming to develop a system or tool to aid designers in designing products for Rapid Manufacturing (RM) processes. The tool is anticipated to provide an interactive guide at early stage of the design process to assist designers in achieving certain design requirement. The aim of the questionnaire is to investigate the need for such a tool. This questionnaire will also explore current understanding of novice designers who are designing for RM. The information included in this questionnaire will only be reproduced in an anonymous manner, and it will only be used to carry out the research stated above.

A. Contact Data:

Name:	Art-Eng Pingsuthiwong
Course and Year:	Master Degree
Email:	song_bongna@hotmail.com

B. Briefly describe the product you have selected for the study for RM.

Spellcheckers

C. What are the specific features that your product needs RM? (Tick all relevant)

- Part complexity
- Ease of part consolidation
- Personalisation requirements
- Form or aesthetics requirement
- Others: _____

D. What are the factors to consider when designing the product base on the feature(s) stated above?

The flexibility of the chosen machine in downstream process limitation

E. Where did you get the information to support your design and meet the features stated on C?

On the internet

F. Can you explain the steps of the design process for this design feature?

To create the concept of design first and then check the ability of RM

G. Which of the rapid manufacturing system you have selected to produce your product?

- Stereolithography Conquest 500
- Fused deposition modeling
- Selective laser sintering
- Others: _____

H. Briefly describe why you have chosen the above system.

It can combine 2 materials on one part.

I. What are the current major challenges to design product for RM?

How can it deal with the internal components that are so complex to construct such as circuit board

J. Are your current RM knowledge and design skills adequate to cope with future industrial requirements? (Please tick the appropriate box)

- Yes
- No
- Don't know

K. Currently, how you equip yourself to design products for Rapid Manufacturing?

Find information first - from lectures / internet

L. If there is a tool/system/method to guide the design process for RM product, how could it guide or assist you before the conceptual stage of the design process?

The benefits that can obtain from RM and the limitations of RM.

M. If there is a tool/system/method to guide the design process for RM product how can it guide or assist the overall RM design process?

First Identifying the features that take advantages of RM.

The simulation of checking the ^{strength} capability to manufacture by

N. Please comment on any other areas of RM / design expertise which you consider RM. would benefit the study.

The file transformation to suitable file types that
might not be good enough as solid modelling.
as

Thank You for you support.

Synopsis:

This questionnaire will be used as part of a research study aiming to develop a system or tool to aid designers in designing products for Rapid Manufacturing (RM) processes. The tool is anticipated to provide an interactive guide at early stage of the design process to assist designers in achieving certain design requirement. The aim of the questionnaire is to investigate the need for such a tool. This questionnaire will also explore current understanding of novice designers who are designing for RM. The information included in this questionnaire will only be reproduced in an anonymous manner, and it will only be used to carry out the research stated above.

A. Contact Data:

Name: NIK SHAHMAN NIK AHMAD ARIFF
 Course and Year: MASTER INDUSTRIAL DESIGN (YEAR 1)
 Email: N.S.Nik-Ahmad-Ariff@lboro.ac.uk

B. Briefly describe the product you have selected for the study for RM.

I choose chose to design a headphone (full-size) for desktop computer & MP3 player.

C. What are the specific features that your product needs RM? ^{the most} (Tick all relevant)

- Part complexity
- Ease of part consolidation
- Personalisation requirements
- Form or aesthetics requirement
- Others: _____

*Rewrite the result.
 at input structure questionnaire.
 Work on structure! Discuss abt
 the CAD
 Talk abt interview*

talk abt what was learn from interview.

D. What are the factors to consider when designing the product base on the feature(s) stated above?

Whether it can be produced easily or not.

E. Where did you get the information to support your design and meet the features stated on C?

Reverse engineering of the existing products.

F. Can you explain the steps of the design process for this design feature?

Reverse engineering existing product → Simplify parts → designing new potential parts.

G. Which of the rapid manufacturing system you have selected to produce your product?

- Stereolithography
- Fused deposition modeling
- Selective laser sintering
- Others: _____

H. Briefly describe why you have chosen the above system.

The method can easily produce the product (without limitation).

I. What are the current major challenges to design product for RM?

The flexibility & potential of the machine.

J. Are your current RM knowledge and design skills adequate to cope with future industrial requirements? (Please tick the appropriate box)

- Yes
- No
- Don't know

K. Currently, how you equip yourself to design products for Rapid Manufacturing?

Knowledge and practical (play around with the process).

L. If there is a tool/system/method to guide the design process for RM product, how could it guide or assist you before the conceptual stage of the design process?

Selection of suitable method to be applied on the design.

M. If there is a tool/system/method to guide the design process for RM product how can it guide or assist the overall RM design process?

Analysis of the whole product - successful or not to be produced with intelligent correction & suggestions.

N. Please comment on any other areas of RM / design expertise which you consider would benefit the study.

Material (research on new potential & cheap material)

Thank You for your support.

Synopsis:

This questionnaire will be used as part of a research study aiming to develop a system or tool to aid designers in designing products for Rapid Manufacturing (RM) processes. The tool is anticipated to provide an interactive guide at early stage of the design process to assist designers in achieving certain design requirement. The aim of the questionnaire is to investigate the need for such a tool. This questionnaire will also explore current understanding of novice designers who are designing for RM. The information included in this questionnaire will only be reproduced in an anonymous manner, and it will only be used to carry out the research stated above.

A. Contact Data:

Name:.....	Fang, Hua
Course and Year:	Visual Product Design 2008 ~ 2009
Email:	hmfang.116@lboro.ac.uk

B. Briefly describe the product you have selected for the study for RM.

Pro Engineer

C. What are the specific features that your product needs RM? (Tick all relevant)

- Part complexity
- Ease of part consolidation
- Personalisation requirements
- Form or aesthetics requirement
- Others: low value

D. What are the factors to consider when designing the product base on the feature(s) stated above?

availability materials frame

E. Where did you get the information to support your design and meet the features stated on C?

Website, reference books

F. Can you explain the steps of the design process for this design feature?

Propose ideas, conceptual sketches, prototyping, modelling, processing, analyzing construction

G. Which of the rapid manufacturing system you have selected to produce your product?

- Stereolithography
- Fused deposition modeling
- Selective laser sintering
- Others: _____

H. Briefly describe why you have chosen the above system.

Fast - Multimaterial, Economical

I. What are the current major challenges to design product for RM?

expensive (for mass production) limited material

J. Are your current RM knowledge and design skills adequate to cope with future industrial requirements? (Please tick the appropriate box)

- Yes
- No
- Don't know

K. Currently, how you equip yourself to design products for Rapid Manufacturing?

having some online tutorials or searching know-how.
online.

L. If there is a tool/system/method to guide the design process for RM product, how could it guide or assist you before the conceptual stage of the design process?

I think the tool or system should be helpful to fulfill my
conceptions effectively, if I have a idea, it will lead me to
the feasible solution at least cost and time based on my proposition

M. If there is a tool/system/method to guide the design process for RM product how can it guide or assist the overall RM design process?

It should function as a bridge to connect the prototyping or
modeling into real product; also, it should be user friendly; accessible.
It aims to ~~make~~ make a trouble-free final production throughout the

N. Please comment on any other areas of RM / design expertise which you consider whole process would benefit the study.

Comments :

in formation. How to simplified the process from prototyping
to production, how to get access to the ~~it~~ real time.
technological support center. how to get material necessary and
selective machine for solutions.

Thank You for you support.

Synopsis:

This questionnaire will be used as part of a research study aiming to develop a system or tool to aid designers in designing products for Rapid Manufacturing (RM) processes. The tool is anticipated to provide an interactive guide at early stage of the design process to assist designers in achieving certain design requirement. The aim of the questionnaire is to investigate the need for such a tool. This questionnaire will also explore current understanding of novice designers who are designing for RM. The information included in this questionnaire will only be reproduced in an anonymous manner, and it will only be used to carry out the research stated above.

A. Contact Data:

Name: FANG JIN ZHANG (Virginia).....
Course and Year: Virtual Product Design 08/09.....
Email: F.ZHANG4-08@student.lboro.ac.uk.....

B. Briefly describe the product you have selected for the study for RM.

~~Beard~~ Beard Shaver

C. What are the specific features that your product needs RM? (Tick all relevant)

- Part complexity
- Ease of part consolidation
- Personalisation requirements
- Form or aesthetics requirement
- Others: _____

D. What are the factors to consider when designing the product base on the feature(s) stated above?

Reduce the number of parts to make it's easy to assemble & use.
Change some structure to let users easy to clean & operate. (Ergonomic)
Improve the appearance. (Aesthetics).

E. Where did you get the information to support your design and meet the features sated on C?

Lecture, website, Reference books, ~~and~~ personal experience.

F. Can you explain the steps of the design process for this design feature?

Think what features can I improve ^(possibility) >> research >> look for support.
>> study >> Build the model >> test >> finish.

G. Which of the rapid manufacturing system you have selected to produce your product?

- Stereolithography
- Fused deposition modeling
- Selective laser sintering
- Others: MMJ (Example: Object)

H. Briefly describe why you have chosen the above system.

Small product by this way, the details can be built better.

I. What are the current major challenges to design product for RM?

The limit knowledge & experience. We have so less chances to do practical exercise. I think RM need many cross fields knowledge.

J. Are your current RM knowledge and design skills adequate to cope with future industrial requirements? (Please tick the appropriate box)

- Yes
- No
- Don't know

K. Currently, how you equip yourself to design products for Rapid Manufacturing?

Enhance my knowledge & experience. Find ~~more~~ information as more as possible.

L. If there is a tool/system/method to guide the design process for RM product, how could it guide or assist you before the conceptual stage of the design process?

Let me know the possibility what RM can benefit / innovate the current product, & what should I notice.

M. If there is a tool/system/method to guide the design process for RM product how can it guide or assist the overall RM design process?

Remind me the key point what should I pay attention & offer the reference resource.

N. Please comment on any other areas of RM / design expertise which you consider would benefit the study.

Mechanical Engineering. Computing Science (Software)
Chemistry (Material) General Physics. ~~Art~~ Art } areas of application

Thank You for you support.

①. Type of RM systems.
②.

Synopsis:

This questionnaire will be used as part of a research study aiming to develop a system or tool to aid designers in designing products for Rapid Manufacturing (RM) processes. The tool is anticipated to provide an interactive guide at early stage of the design process to assist designers in achieving certain design requirement. The aim of the questionnaire is to investigate the need for such a tool. This questionnaire will also explore current understanding of novice designers who are designing for RM. The information included in this questionnaire will only be reproduced in an anonymous manner, and it will only be used to carry out the research stated above.

A. Contact Data:

Name:.....	Danyan Zhu.....
Course and Year:	Msc Sustainable Product Design 08-09.
Email:	blue_fei@hotmail.com.....

B. Briefly describe the product you have selected for the study for RM.

A fm receiver; It's about 38 mm wide and 25 mm long, A quite cheap product.

C. What are the specific features that your product needs RM? (Tick all relevant)

- Part complexity
- Ease of part consolidation
- Personalisation requirements
- Form or aesthetics requirement
- Others: _____

D. What are the factors to consider when designing the product base on the feature(s) stated above?

Easy to hold in hand, so the shape must not too strange. I also designed some parts to avoid dropping from hands.

E. Where did you get the information to support your design and meet the features stated on C?

From lectures, tutorials, relevant website, books...

F. Can you explain the steps of the design process for this design feature?

1. analyze the features of the original FM receiver. 2. design the appearance according to the external part. 3. modeling (use proE).

G. Which of the rapid manufacturing system you have selected to produce your product?

- Stereolithography
- Fused deposition modeling
- Selective laser sintering
- Others: _____

H. Briefly describe why you have chosen the above system.

The shell of this product is easy to achieve by fused deposition modeling.

I. What are the current major challenges to design product for RM?

Lack of real RM experiences.

J. Are your current RM knowledge and design skills adequate to cope with future industrial requirements? (Please tick the appropriate box)

- Yes
- No
- Don't know

K. Currently, how you equip yourself to design products for Rapid Manufacturing?

Get information from books to analyze the feasibility of my product for RM

L. If there is a tool/system/method to guide the design process for RM product, how could it guide or assist you before the conceptual stage of the design process?

I hope it can provide a mock situation in order to give users the overview about the RM process

M. If there is a tool/system/method to guide the design process for RM product how can it guide or assist the overall RM design process?

It can provide the information about the material use, the manufacturing system choose etc.

N. Please comment on any other areas of RM / design expertise which you consider would benefit the study.

Thank You for your support.

Synopsis:

This questionnaire will be used as part of a research study aiming to develop a system or tool to aid designers in designing products for Rapid Manufacturing (RM) processes. The tool is anticipated to provide an interactive guide at early stage of the design process to assist designers in achieving certain design requirement. The aim of the questionnaire is to investigate the need for such a tool. This questionnaire will also explore current understanding of novice designers who are designing for RM. The information included in this questionnaire will only be reproduced in an anonymous manner, and it will only be used to carry out the research stated above.

A. Contact Data:

Name:.....	QIAN QING YAO
Course and Year:	M.Sc. INDUSTRIAL DESIGN , FINAL
Email:	TERRA007 YAO

B. Briefly describe the product you have selected for the study for RM.

A WALKIE & TALKIE HANDSET FOR RECREATIONAL PURPOSE USE

C. What are the specific features that your product needs RM? (Tick all relevant)

- Part complexity
- Ease of part consolidation
- Personalisation requirements
- Form or aesthetics requirement
- Others: _____

D. What are the factors to consider when designing the product base on the feature(s) stated above?

~~FREE FORMED PERSONALISED / AESTHETICS SHAPE CAN INCREASE THE DIFFICULTY IN MODELLING FOR DESIGNER~~
REDUCE THE NO. OF COMPONENTS TO SAVE COST & ASSEMBLY TIME BY INTEGRATING THOSE FEATURES TOGETHER IN MIN. NUMBER

E. Where did you get the information to support your design and meet the features stated on C?

INTERNET & RELATIVE READINGS

F. Can you explain the steps of the design process for this design feature?

BROWSING & RESEARCH → IDENTIFY RM ADVANTAGE & PRODUCT SELECTION
→ RESEARCH FOR EXISTING PRODUCT & EXPLORE POTENTIAL IMPROVEMENTS TO BE MADE → DESIGN FOR R.M. → EVALUATING & REDESIGN. → MODELL

G. Which of the rapid manufacturing system you have selected to produce your product?

- Stereolithography
- Fused deposition modeling
- Selective laser sintering
- Others: _____

H. Briefly describe why you have chosen the above system.

FLEXIBILITY IN MATERIAL SELECTION

I. What are the current major challenges to design product for RM?

TRANSFER DESIGN IDEA TO A CAD MODEL

J. Are your current RM knowledge and design skills adequate to cope with future industrial requirements? (Please tick the appropriate box)

- Yes
- No
- Don't know

K. Currently, how you equip yourself to design products for Rapid Manufacturing?

EQUIP MYSELF BY USING UNIVERSITY RESOURCE

L. If there is a tool/system/method to guide the design process for RM product, how could it guide or assist you before the conceptual stage of the design process?

MAYBE ASSISTANT ON ANALYSING CONCEPTS OF A DESIGN WOULD BE HELPFUL

M. If there is a tool/system/method to guide the design process for RM product how can it guide or assist the overall RM design process?

ASSISTANT ON FREEFORMED SHAPE MODELLING WILL BE ESSENTIAL & EFFECTIVE TO REDUCE THE TIME & DIFFICULTIES FOR DESIGNER

N. Please comment on any other areas of RM / design expertise which you consider would benefit the study.

Thank You for you support.

102 2020/21 1000

Synopsis:

This questionnaire will be used as part of a research study aiming to develop a system or tool to aid designers in designing products for Rapid Manufacturing (RM) processes. The tool is anticipated to provide an interactive guide at early stage of the design process to assist designers in achieving certain design requirement. The aim of the questionnaire is to investigate the need for such a tool. This questionnaire will also explore current understanding of novice designers who are designing for RM. The information included in this questionnaire will only be reproduced in an anonymous manner, and it will only be used to carry out the research stated above.

A. Contact Data:

Name:.....	MARCUS HARRATTY
Course and Year:	MA SUSTAINABLE DES, 1/1
Email:	MARCUSHARRATTY@LBO.AC.UK

B. Briefly describe the product you have selected for the study for RM.

SPEAKER CLUSTER AND CONTROL UNIT -
1 BASS SPEAKER + 2 TWEETERS COMBINED.

C. What are the specific features that your product needs RM? (Tick all relevant)

- Part complexity
- Ease of part consolidation
- Personalisation requirements
- Form or aesthetics requirement
- Others: CONSOLIDATION OF DUAL MATERIAL
SINGLE COMPONENTS.

D. What are the factors to consider when designing the product base on the feature(s) stated above?

ABILITY TO ABANDON NORMAL MOLDING LOWSTRIKING,
REMOVAL OF FASTENERS, CERAMIC AESTHETICS

E. Where did you get the information to support your design and meet the features stated on C?

WEB - REDEYE, CONSOLIDATION OF MULTIPLE
EXISTING FORMS, LECTURES, NATURAL GEOMETRY

F. Can you explain the steps of the design process for this design feature?

SELECTION OF OBJECT TO SUIT RM, GENERATION
OF KEY PERFORMANCE FEATURES AND TRANSLATION INTO
RM SUITABLE, FINAL DESIGN FEATURE WERE DESIGNED
IN CAD ASSEMBLY AS THEY DID NOT REQUIRE PRE-PLANNING

G. Which of the rapid manufacturing system you have selected to produce your FOR MSLD DESI product?

- Stereolithography
- Fused deposition modeling
- Selective laser sintering
- Others: _____

H. Briefly describe why you have chosen the above system.

ABILITY TO USE 2 MATERIALS - ABS & ELASTOMER,
GOOD TOLERANCE + SURFACE FINISH

I. What are the current major challenges to design product for RM?

TRANSLATING DESIRED DESIGN FEATURES
INTO CAD GEOMETRY

J. Are your current RM knowledge and design skills adequate to cope with future industrial requirements? (Please tick the appropriate box)

- Yes
- No
- Don't know

K. Currently, how you equip yourself to design products for Rapid Manufacturing?

THE HUGE POSSIBILITIES OF RM ARE UNDERSTOOD;
BUT ANY DESIGN HAS TO BE FILTERED
THROUGH MY CAD CAPABILITIES.

L. If there is a tool/system/method to guide the design process for RM product, how could it guide or assist you before the conceptual stage of the design process?

GRAPHIC LIBRARY OF ACHIEVABLE FORMS, VIDEOS
OF RM MACHINES IN ACTION, LIBRARY OF PART CONSOLIDATION
I.E. BUILT IN BUTTONS ETC.

M. If there is a tool/system/method to guide the design process for RM product how can it guide or assist the overall RM design process?

IN ADDITION TO ABOVE, A CAD BASE GUIDE (LIKE COACH)
TO ACHIVING RM SPECIFIC GEOMETRY, PERHAPS
BASED AROUND COMPLEX 3D FORMS - DIATOMS, SEA SHELLS

N. Please comment on any other areas of RM / design expertise which you consider would benefit the study.

SPECIFIC MATERIAL LIBRARY - WITH
PROPERTIES BUT ALSO WITH SUITABLE MATERIALS

FOR DUAL MANUFACTURE. EG. ABS + ELASTOMER

RED EYE HAVE GOOD
COMPARISON SHEET.

Thank You for you support.

Synopsis:

This questionnaire will be used as part of a research study aiming to develop a system or tool to aid designers in designing products for Rapid Manufacturing (RM) processes. The tool is anticipated to provide an interactive guide at early stage of the design process to assist designers in achieving certain design requirement. The aim of the questionnaire is to investigate the need for such a tool. This questionnaire will also explore current understanding of novice designers who are designing for RM. The information included in this questionnaire will only be reproduced in an anonymous manner, and it will only be used to carry out the research stated above.

A. Contact Data:

Name: Yan Zhang
Course and Year: Product Design in Business 2008-2009
Email: summer.706@hotmail.com

B. Briefly describe the product you have selected for the study for RM.

I chose the portable folded hairdrier

C. What are the specific features that your product needs RM? (Tick all relevant)

- Part complexity
- Ease of part consolidation
- Personalisation requirements
- Form or aesthetics requirement
- Others: _____

D. What are the factors to consider when designing the product base on the feature(s) stated above? The parts connection, structure, is there any Ease of part consolidation part is useless

E. Where did you get the information to support your design and meet the features sated on C?

Searching on the Internet ^{to} find useful informations and look at other product's structure

F. Can you explain the steps of the design process for this design feature?

I chose the similar products and analysis is structure, good point and bad point, ~~or~~ then design my product.

G. Which of the rapid manufacturing system you have selected to produce your product?

- Stereolithography
- Fused deposition modeling
- Selective laser sintering
- Others: _____

H. Briefly describe why you have chosen the above system.

Based on my design's shape & material.

I. What are the current major challenges to design product for RM?

The limit of RM knowledge and experience

J. Are your current RM knowledge and design skills adequate to cope with future industrial requirements? (Please tick the appropriate box)

- Yes
- No
- Don't know

K. Currently, how you equip yourself to design products for Rapid Manufacturing?

Ask Ian for suggestion and look at other similar products, collect info related.

L. If there is a tool/system/method to guide the design process for RM product, how could it guide or assist you before the conceptual stage of the design process?

give some case studies and RM suggestion? images/photos.

M. If there is a tool/system/method to guide the design process for RM product how can it guide or assist the overall RM design process?

It could be like a coach teach us how the RM process. Video conference etc.

N. Please comment on any other areas of RM / design expertise which you consider would benefit the study.

- Design Process → ? Factors that should be considered!
- Manufacture Process

Thank You for you support.

Synopsis:

This questionnaire will be used as part of a research study aiming to develop a system or tool to aid designers in designing products for Rapid Manufacturing (RM) processes. The tool is anticipated to provide an interactive guide at early stage of the design process to assist designers in achieving certain design requirement. The aim of the questionnaire is to investigate the need for such a tool. This questionnaire will also explore current understanding of novice designers who are designing for RM. The information included in this questionnaire will only be reproduced in an anonymous manner, and it will only be used to carry out the research stated above.

A. Contact Data:

Name: ... DAVID KEER
Course and Year: ... MA INDUSTRIAL DESIGN YR 1 of 1
Email: ... davekeer84@hotmail.co.uk

B. Briefly describe the product you have selected for the study for RM.

DIGITAL MULTIMETER - A DEVICE FOR TESTING THE FLOW OF
CURRENT THROUGH A WIRE / CIRCUIT

C. What are the specific features that your product needs RM? (Tick all relevant)

- Part complexity
- Ease of part consolidation
- Personalisation requirements
- Form or aesthetics requirement
- Others: _____

D. What are the factors to consider when designing the product base on the feature(s) stated above?

MATERIALS, HOW TO LINK PARTS TOGETHER (CATENES, JOINTS etc)
HOW TO INSERT AND HOLD INTERNAL PARTS

E. Where did you get the information to support your design and meet the features stated on C?

VIEWING OTHER PRODUCTS (CROSS INFORMATION TRANSFER)
LECTURES, INTERNET, TRIAL AND ERROR

F. Can you explain the steps of the design process for this design feature?

PART CONSOLIDATION - ERGONOMIC VALUES - AESTHETICS

G. Which of the rapid manufacturing system you have selected to produce your product?

- Stereolithography
- Fused deposition modeling
- Selective laser sintering
- Others: _____

H. Briefly describe why you have chosen the above system.

DUE TO THE ACCURACY & SURFACE FINISH IT WOULD HAVE FOR MY PRODUCT
ALSO IT IS APPROPRIATE FOR THE SIZE OF MY PRODUCT

I. What are the current major challenges to design product for RM?

QUANTITY OF PRODUCTION, CERTAIN MATERIALS CAN BE FRAGILE, MULTIPLE
MATERIAL SELECTION, COLOUR SELECTION OPTIONS

J. Are your current RM knowledge and design skills adequate to cope with future industrial requirements? (Please tick the appropriate box)

- Yes
- No
- Don't know

K. Currently, how you equip yourself to design products for Rapid Manufacturing?

BY UNDERSTANDING WHAT PRODUCTS ARE SUITABLE FOR THE USE OF RM, BOTH BY THEIR PHYSICAL FEASIBILITY AND BY THEIR FINANCIAL FEASIBILITY.

L. If there is a tool/system/method to guide the design process for RM product, how could it guide or assist you before the conceptual stage of the design process?

AN TOOL WHICH WOULD ALLOW A GREATER UNDERSTANDING OF THE EXISTING INTERNAL PARTS IN RELATION TO THE MACHINE

M. If there is a tool/system/method to guide the design process for RM product how can it guide or assist the overall RM design process?

HAVING A SYSTEM WITHIN CAD PACKAGES WHICH WOULD HIGHLIGHT ANY FORESEEN RM PROBLEMS IE GAPS, MATERIAL SELECTION

N. Please comment on any other areas of RM / design expertise which you consider would benefit the study.

PLACING INTERNALS INTO THE MACHINE AND DESIGNING AROUND

Thank You for you support.

APPENDIX B
USER FIT REQUIREMENT DESIGN FEATURES

AM Reason 1: User fit requirement
Sub Category (a): Sport

Design Feature: Body Contour Feature
Application(i): Protective Sport Garment

Functionality Keywords:

- i. Ergonomic
- ii. Light Weight
- iii. Reduce injury

AM System: SLS

Material: Polymer

Investigators: Richard Hague , Roy Jones,
Andy Harland, Loughborough University

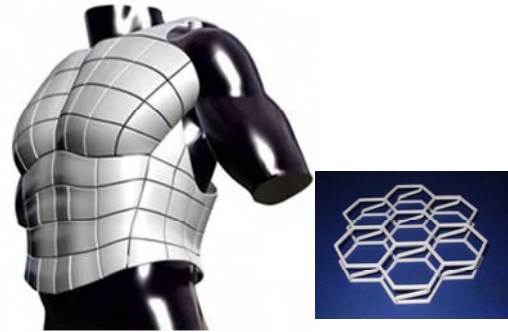

AM Reason 1: User fit requirement
Sub Category (a): Sport

Design Feature: Air Ventilation Feature
Application (ii): Rowing Safety Helmet

Functionality Keywords:

- i. Ergonomic
- ii. Light Weight
- iii. Reduce injury

System: SLS

Material: Polymer

Designer : TNO, Holland



AM Reason 1: User fit requirement
Sub Category (a): Sport

Application (iii): Customised Football Boot

Design Feature: Hollow Studs

Functionality Keywords:

- i. Ergonomic
- ii. Light Weight

System: SLS

Material: Polymer

Designer : www.gizmag.com



AM Reason 1: User fit requirement
Sub Category (a): Sport

Design Feature: Hand Grip Contour Feature

Application (iv): Golf Club Grip

Functionality Keywords:



- i. Ergonomic
- ii. Light Weight
- iii. Increase comfort

AM System: SLS

Material: Polymer

Designer: Olaf Diegel, Auckland University of
Technology, New Zealand

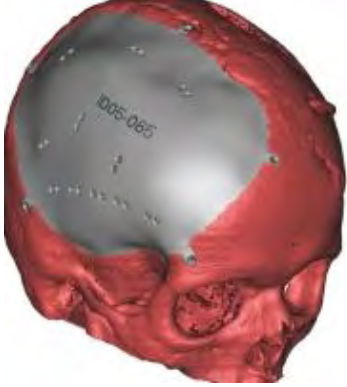

<p>AM Reason 1: User fit requirement Sub Category (b): Medical</p> <p>Design Feature: Ear Canal Contour Application (i): Hearing Aid Functionality Keywords:</p> <ul style="list-style-type: none"> i. Ergonomic <p>AM System: SLS Material: Bio-Compatible Material Source: http://home.att.net/~edgrenda/pow/pow17.htm</p>	
<p>AM Reason 1: User fit requirement Sub Category (b): Medical</p> <p>Design Feature: Tooth Contour Application (ii): Dental Replacement Functionality Keywords:</p> <ul style="list-style-type: none"> i. Ergonomic ii. Durable <p>AM System: SLS Material: Thermoplastic Source: www.materialise.com</p>	
<p>AM Reason 1: User fit requirement Sub Category (b): Medical</p> <p>Design Feature: Convex Concave Skull Contour Application (iii): Human Skull Replacement Functionality Keywords:</p> <ul style="list-style-type: none"> i. Ergonomic <p>AM System: Electron Beam Melting Material: Titanium powder Ti6Al4V Source: www.materialise.com</p>	

AM Reason 1: User fit requirement
Sub Category (b): Medical

Design Feature: Jaw Contour
Application (iv): Jaw Reconstruction
Functionality Keywords:

- i. Ergonomic

AM System: EBM
Material: Titanium
Source: www.sme.org



AM Reason 1: User fit requirement
Sub Category (b): Medical

Design Feature: Limb Contour
Application (v): Humeral Mount for Prostatic Limb
Functionality Keywords:

- i. Ergonomic
- ii. Consolidation

AM System: SLS
Material: Titanium
Source: www.timecompression.com





AM Reason 1: User fit requirement
Sub Category (b): Medical

Design Feature: Knee Contour
Application (vi): Knee Implant
Functionality Keywords:

- i. Ergonomic
- ii. Light Weight
- iii. Strength

AM System: SLS
Material: Metal
Source: EOS



<p>AM Reason 1: User fit requirement Sub Category (b): Medical</p> <p>Design Feature: Bone Contour</p> <p>Application (vii): Fracture Fixation Implant Functionality Keywords:</p> <ul style="list-style-type: none"> i. Ergonomic ii. Light Weight iii. Strength <p>AM System: EBM Material: Titanium Source: www.moldmakingtechnology.com</p>	
<p>AM Reason 1: User fit requirement Sub Category (b): Medical</p> <p>Design Feature: Spinal Contour</p> <p>Application (viii): Spinal Cage Functionality Keywords:</p> <ul style="list-style-type: none"> i. Ergonomic ii. Light Weight iii. Strength <p>AM System: EBM Material: Titanium Source: www.moldmakingtechnology.com</p>	
<p>AM Reason 1: User fit requirement Sub Category (b): Medical</p> <p>Design Feature: Leg Contour</p> <p>Application (ix): Prosthetic Part Functionality Keywords:</p> <ul style="list-style-type: none"> i. Ergonomic ii. Light Weight iii. Strength <p>AM System: SLS Material: Polymer Source : www.peridotinc.com</p>	

AM Reason 1: User fit requirement
Sub Category (c): Consumer Product

Design Feature: Wrist Contour Feature

Application (i): Fashion - Bangle Cuff

Functionality Keywords:

- i. Ergonomic

AM System: SLS

Material: Polymer

Source: Anthony Tamaro



AM Reason 1: User fit requirement
Sub Category (c): Consumer Product

Design Feature: Body Contour Feature

Application (ii): Chair

Functionality Keywords:

- i. Ergonomic
- ii. Aesthetics

AM System: SLS

Material: Polymer

Source: Ammar Eloueini



AM Reason 1: User fit requirement
Sub Category (c): Consumer Product

Design Feature: Hand Grip Contour Feature

Application (iii): Joystick

Functionality Keywords:

- i. Ergonomic
- ii. Reduce fatigue
- iii. Increase comfort

AM System: SLS

Material: Polymer

Designer : Chris Newland, Loughborough University,
UK



AM Reason 1: User fit requirement
Sub Category (c): Consumer Product

Design Feature: Hand Grip Contour Feature

Application (iv): Ratchet

Functionality Keywords:

- i. Ergonomic
- ii. Reduce fatigue

AM System: FDM

Material: Polymer

Source: www.stratasys.com



AM Reason 1: User fit requirement
Sub Category (c): Consumer Product

Design Feature: Body Contour Feature

Application (v): Chair

Functionality Keywords:

- i. Ergonomic
- ii. Aesthetics

AM System: SLS

Material: Polymer

Source: www.oobject.com



AM Reason 1: User fit requirement
Sub Category (c): Consumer Product

Design Feature: Body Contour Design

Application (vi): Car Seat

Functionality Keywords:

- i. Ergonomic
- ii. Reduce fatigue

AM System: SLS



Material: Polymer

Source: www.materialise.com







APPENDIX C
IMPROVE FUNCTIONALITY DESIGN FEATURES

<p>AM Reason 2: Improve Functionality Sub Category (a): Weight Reduction Design Feature (i): Undercut Application: Motorbike Meter Housing Functionality Keywords:</p> <ul style="list-style-type: none"> i. Parts Consolidation ii. Variable Wall Thickness <p>AM System: SLS Material: Polycarbonate</p> <p>Source : www.fortus.com</p>	
<p>AM Reason 2: Improve Functionality Sub Category (a): Weight Reduction Design Feature (ii): Thin Wall Feature Application: Clipping Device Functionality Keywords:</p> <ul style="list-style-type: none"> i. Flexible ii. Light weight <p>AM System: SLS Material : DuraForm EX plastic Source: 3D Systems</p>	
<p>AM Reason 2: Improve Functionality Sub Category (a): Weight Reduction</p> <p>Design Feature (iii): Hollow Feature Application: Stool Functionality Keywords:</p> <ul style="list-style-type: none"> i. Aesthetics ii. Light weight <p>AM System: SLS Material : Polymer Source: www.freedomofcreation.com</p>	
<p>AM Reason 2: Improve Functionality Sub Category (a): Weight Reduction Design Feature (iv): Variable Wall Thickness Feature Application: Automotive Ventilation Functionality Keywords:</p> <ul style="list-style-type: none"> i. Ventilation ii. Reduce Energy Consumption iii. Light Weight iv. Ease of Mounting <p>AM System: SLS , Material: Nylon Designer : Peter</p>	

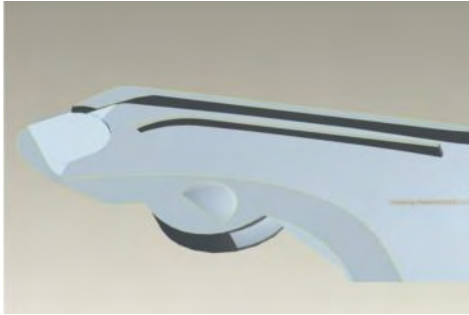
<p>Sever, University of Maribor, Slovenia</p>	
<p>AM Reason 2: Improve Functionality Sub Category (a): Weight Reduction Design Feature (v): Internal Selective Reinforced Feature Application: Stool Functionality Keywords:</p> <ul style="list-style-type: none"> i. Aesthetics ii. Light Weight <p>AM System: SLS Material: Nylon Designer : Bram Geenen, YankoDesign.Com</p>	
<p>AM Reason 2: Improve Functionality Sub Category (b): Weight Reduction Design Feature (vi): Honey Comb Feature Application: Car Grill Functionality Keywords:</p> <ul style="list-style-type: none"> i. Strength ii. Light Weight iii. Aesthetic <p>AM System: SLS Material: Polymer Source : www.arrk.com</p>	
<p>AM Reason 2: Improve Functionality Sub Category (b): Weight Reduction Design Feature (vi): External Ribbing Application: Functionality Keywords:</p> <ul style="list-style-type: none"> i. Strength ii. Light Weight <p>AM System: SLS Material: Polymer Source : www.3trpd.co.uk</p>	

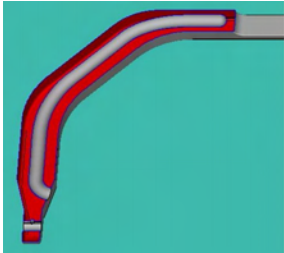
<p>AM Reason 2: Improve Functionality</p> <p>Sub Category (b): Increase Surface Friction</p> <p>Design Feature (i): Textured Surface Application: Product Enclosure Functionality Keywords:</p> <ul style="list-style-type: none"> i. Improve friction ii. Improve appearance <p>AM System: SLS Material: Metal Source : www.crestock.com</p>	
<p>AM Reason 2: Improve Functionality</p> <p>Sub Category (b): Increase Surface Friction</p> <p>Design Feature (ii): Circular Array Feature Application: Tray Functionality Keywords:</p> <ul style="list-style-type: none"> i. Improve friction ii. Aesthetics <p>AM System: SLS Material: Polymer Source : www.freedomofcreation.com</p>	
<p>AM Reason 2: Improve Functionality</p> <p>Sub Category (b): Increase Surface Friction</p> <p>Design Feature (iii): Honey Comb Feature Application: Tray Functionality Keywords:</p> <ul style="list-style-type: none"> i. Improve friction ii. Aesthetics <p>AM System: SLS Material: Polymer Source : www.materialise.com</p>	

<p>AM Reason 2: Improve Functionality</p> <p>Sub Category (c): Internal Structuring</p> <p>Design Feature (i): Internal Cable Route</p> <p>Application: Electronics and electrical product</p> <p>Functionality Keywords:</p> <ul style="list-style-type: none"> i. channel ii. internal geometry iii. cable routing <p>AM System: SLS Material : Nylon Designer: Ian Campbell, Loughborough University, UK</p>	
<p>AM Reason 2: Improve Functionality</p> <p>Sub Category (c): Internal Structuring</p> <p>Design Feature (ii): Internal flow path</p> <p>Application: Medical Device</p> <p>Functionality Keywords:</p> <ul style="list-style-type: none"> i. Light weight ii. Patients size variation <p>AM System: SLS Material: Stainless steel Designer : Carlos García Pando, Prodintec, Spain</p>	 
<p>AM Reason 2: Improve Functionality</p> <p>Sub Category (c): Internal Structuring</p> <p>Design Feature (iii): Internal Blade Feature</p> <p>Application: Aerospace parts</p> <p>Functionality Keywords:</p> <ul style="list-style-type: none"> i. Creep resistance ii. Fatigue resistance <p>AM System: SLS Material: Cobalt Chrome, Stainless Steel, Titanium, Maraging Steel</p> <p>Source: www.3trpd.co.uk</p>	

AM Reason 2: Improve Functionality
Sub Category (c): Internal Structuring

Design Feature (v): Internal Cooling Feature

Functionality Keywords:

- i. Strength
- ii. Light Weight

Application: Laser collimator for space applications

AM System: DMLS

Material: DM20 – Direct metal including bronze material

Source: www.crif.be

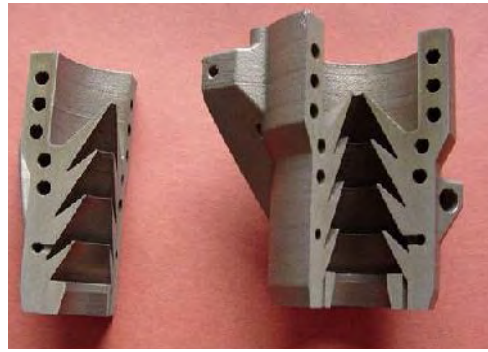

AM Reason 2: Improve Functionality
Sub Category (c): Internal Structuring

Design Feature (vi): Internal Shelving

Application: Avionic Enclosure

Functionality Keywords:

- i. positioning
- ii. assembly
- iii. housing

AM System: SLS

Material: Nylon

Designer: Du Plessis, Saab Aviatronics, South Africa



AM Reason 2: Improve Functionality
Sub Category (c): Internal Structuring

Design Feature (vii): Internal Shelving

Application: Aerospace Fuel Injection–Swirlers

Functionality Keywords:

- i. strength
- ii. light weight
- iii. heat resistance

AM system: SLS

Material: Metal

Source: EOS



AM Reason 2: Improve Functionality
Sub Category (c): Internal Structuring

Design Feature (viii): Internal cable support

Application: electronic enclosure

Functionality Keywords:

- iv. positioning
- v. assembly
- vi. housing

AM system: SLS

Material: Polymer

Source: Du Plessis, Saab Aviatronics, South Africa

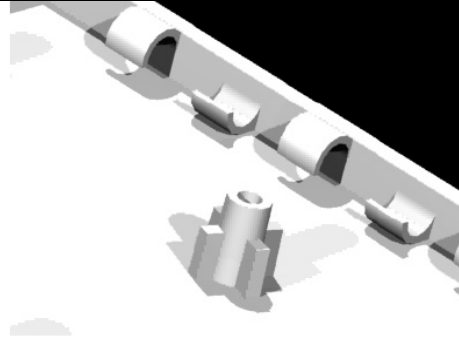

AM Reason 2: Improve Functionality
Sub Category (c): Internal Structuring

Design Feature (ix): encapsulated spring feature

Application: Consumer Product

Functionality Keywords:

- i. internal geometry

AM system: SLS

Material: Polymer

Source: G. Gerber (MSc Thesis - Design for Rapid Manufacturing)

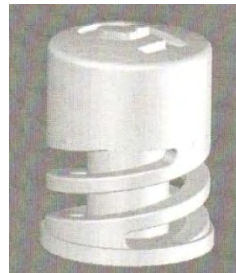
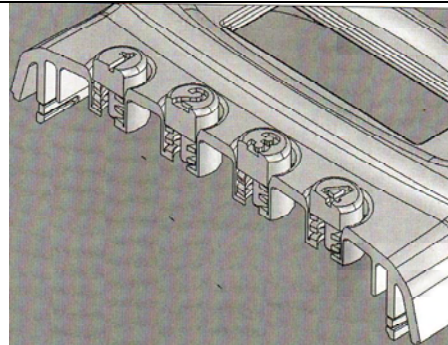

AM Reason 2: Improve Functionality
Sub Category (d): Multiple Versions

Design Feature (i): Size Variations
Application: Screw Driver

Functionality Keywords:

- i. **Fastening**

Material: NA

Designer : Mike Burton

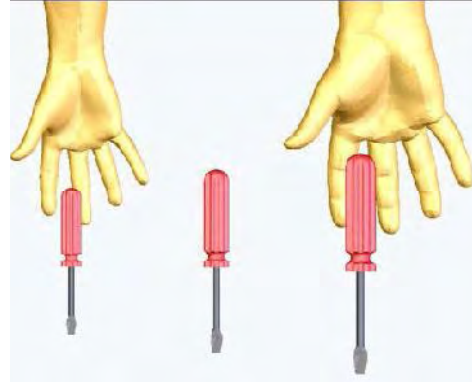

AM Reason 2: Improve Functionality
Sub Category (d): Multiple Versions

Design Feature (ii): Customised Thread
Application: Fastening

Functionality Keywords:

- i. Fastening
- ii. Light Weight



AM System: SLS

Material: Thermoplastic

Source : <http://www.stratasys.com>

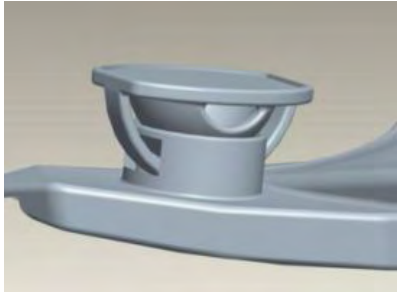
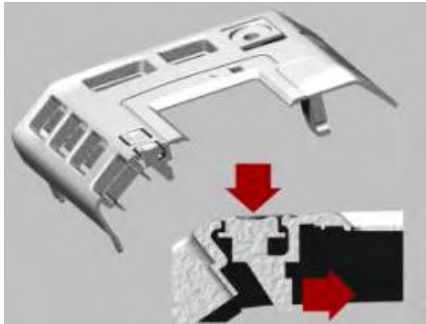

APPENDIX D
CONSOLIDATION REQUIREMENT DESIGN FEATURES

<p>AM Reason 3: Consolidation Sub Category (a): Instant Assembly Design Feature (i): Integrated ball and socket feature</p> <p>Application: Consumer product Functionality Keywords:</p> <ol style="list-style-type: none"> i. Ball joint ii. Encapsulation iii. Spherical movement iv. Self-levelling v. Ready assembled <p>AM System: SLS Material: Polymer Designer: Ian Campbell, Loughborough University, UK</p>	
<p>AM Reason 3: Consolidation Sub Category (a): Instant Assembly Design Feature (ii): Internal Hinged Button Feature</p> <p>Application: Automotive Functionality Keywords:</p> <ol style="list-style-type: none"> i. Integral button ii. Internal access iii. Hinge iv. Orthogonal operation <p>AM System: SLS Material: Polymer Designer : Mike Burton, RMIT Australia</p>	
<p>AM Reason 3: Consolidation Sub Category (a): Instant Assembly Design Feature (iii): Enclosed Volume Feature</p> <p>Application: Automotive Racing Engine Functionality Keywords:</p> <ol style="list-style-type: none"> i. Light Weight ii. Durability iii. Strength <p>AM System: SLS Material: Polymer Source: www.3trpd.co.uk</p>	

AM Reason 3: Consolidation
Sub Category (a): Instant Assembly
Design Feature (iv): Ready assemble gear

Application: Engineering
Functionality Keywords:

- i. Transmit Rotation
- ii. Consolidation

AM System: SLS
Material: Polymer
Source: Ian Campbell, Loughborough University, UK



AM Reason 3: Consolidation
Sub Category (a): Instant Assembly
Design Feature (v): Interwoven Feature

Application: Fabric
Functionality Keywords:

- i. Aesthetics
- ii. Instant assembly

AM System: SLS
Material: Nylon
Designer:

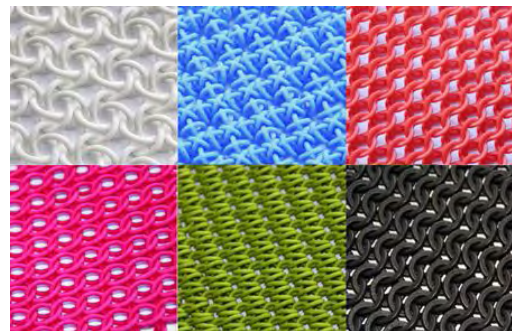

AM Reason 3: Consolidation
Sub Category (a): Instant Assembly
Design Feature (vi): Encapsulated bearing

Application: Prototype Bearing
Functionality Keywords:

- i. Transmit Rotation
- ii. Consolidation

AM System: SLS
Material: Polymer
Designer : Ian Campbell, Loughborough University, UK



AM Reason 3: Consolidation
Sub Category (a): Instant Assembly
Design Feature (vii): Ball & Socket Joint

Application: Customised webcam
 Functionality Keywords:

- i. Fastening
- ii. Consolidation
- iii. Holding
- iv. Securing

AM System: FDM
 Material: ABS
 Designer : Eric Callister, Scott Gibby, Jake Lamb, and Steve Wood, Utah State University

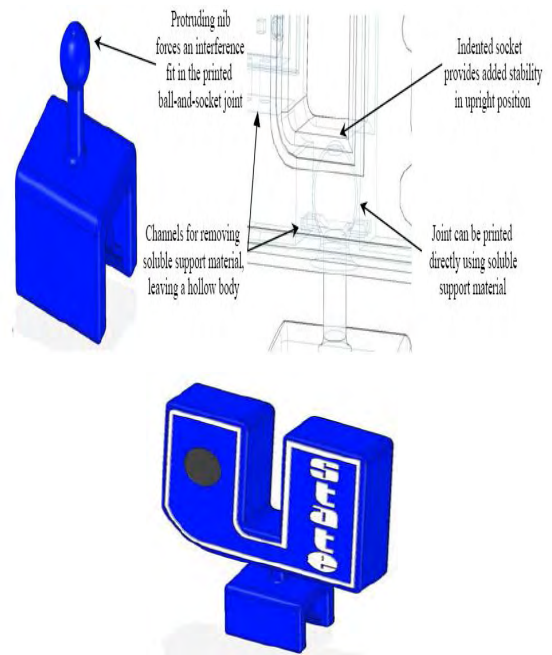

AM Reason 3: Consolidation
Sub Category (a): Instant Assembly
Design Feature (viii): Self Centring feature

Application: Fastening
 Functionality Keywords:

- i. Ease of Mounting
- ii. Aesthetics
- iii. Quick release hinge

AM System: SLS
 Material: Polymer
 Source : EOS



AM Reason 3: Consolidation
Sub Category (a): Instant Assembly
Design Feature (ix): Foldable Living Hinge

Application: Consumer Products
 Functionality Keywords:

- i. Quick release hinge

AM System: SLS
 Material: Polymer
 Source : EOS



AM Reason 3: Parts Consolidation
Sub Category (a): Instant Assembly
Design Feature (x): Circular Living Hinge

Application: Consumer Products
Functionality Keywords:

- i. Quick release hinge

AM System: SLS
Material: Polymer
Source : EOS



AM Reason 3: Consolidation
Sub Category (a): Instant Assembly
Design Feature (xi): Movable Element

Application: Air Vent
Functionality Keywords:

- i. Fastening
- ii. Consolidation
- iii. Holding

AM System: SLS
Material: Polymer
Source : www.butler.com/newsletter//manufactu



AM Reason 3: Consolidation
Sub Category (a): Instant Assembly
Design Feature (xii): Encapsulated Track & Ball Feature

Application: Model Track
Functionality Keywords:

- i. Consolidation
- ii. Holding

AM System: SLS
Material: Polymer
Source : Joe Beaman

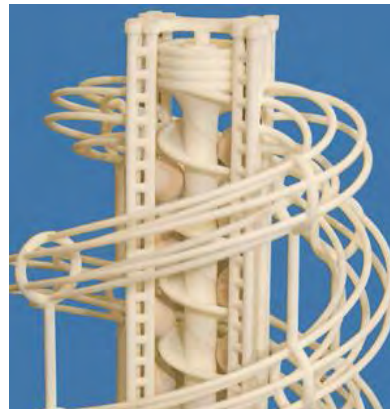

AM Reason 3: Consolidation
Sub Category (a): Instant Assembly
Design Feature (xiii): Encapsulated Spring
Lock Feature

Application: Fastening
Functionality Keywords:

- i. Spring Element

AM System: SLS
Material: Polymer
Source : EOS



AM Reason 3: Consolidation
Sub Category (a): Instant Assembly
Design Feature (xiv): Interconnect Feature

Application: Bowl
Functionality Keywords:

- i. Aesthetics

AM System: SLS
Material: Polymer
Source : Janne Kytanen



AM Reason 3: Consolidation
Sub Category (a): Instant Assembly
Design Feature (xv): Torus feature

Application: Lightning
Functionality Keywords:

- i. Aesthetics

AM System: SLS
Material: Polymer
Source : Jiri Evenhuis



AM Reason 3: Consolidation
Sub Category (a): Instant Assembly
Design Feature (xvi): Foldable Feature

Application: Stool
Functionality Keywords:

- i. Aesthetics
- ii. Quick release hinges

AM System: SLS
Material: Polymer
Source : Patrick Jouin



AM Reason 3: Consolidation
Sub Category (a): Instant Assembly
Design Feature (xvii): Flexible Join

Application: Enclosures
Functionality Keywords:

- i. Fastening
- ii. Quick release hinge
- iii. Consolidation

AM System: SLS
Material: Polymer
Source : EOS



AM Reason 3: Consolidation
Sub Category (a): Instant Assembly
Design Feature (xviii): Multiple Links

Application: Table Light
Functionality Keywords:

- i. Aesthetics

AM System: SLS
Material: Polymer
Source: www.materialise.com



AM Reason 3: Consolidation
Sub Category (b): Fasteners Removal
Design Feature (i) : Snap fit hook

Application: Avionic Enclosure
Functionality Keywords:

- i. fastening
- ii. holding
- iii. positioning

AM System: SLS
Material: Polymer
Designer: Du Plessis, Saab Aviatronics,
South Africa

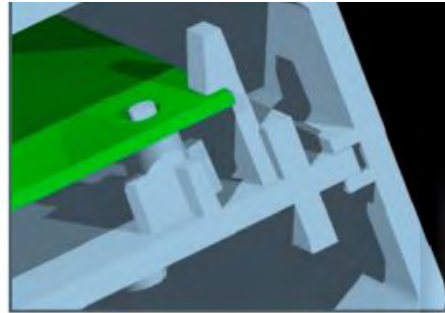

AM Reason 3: Consolidation
Sub Category (b): Fasteners Removal
Design Feature (ii) : Mounting Boss

Feature

Application: Avionic Enclosure
Functionality Keywords:

- i. locating
- ii. positioning
- iii. assembly

AM System: SLS
Material: Polymer
Designer: Du Plessis, Saab Aviatronics,
South Africa

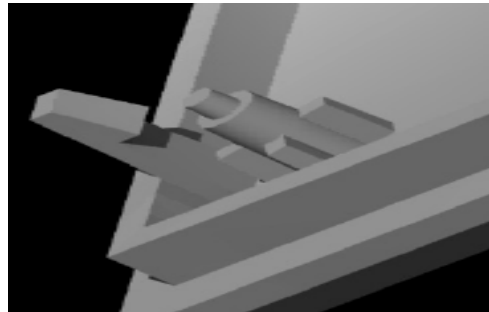

AM Reason 3: Consolidation
Sub Category (b): Remove Fasteners
Design Feature (iii) : Hook Clip





feature

Application: Product Enclosure
Functionality Keywords:

- i. locating
- ii. assembly
- iii. fastening

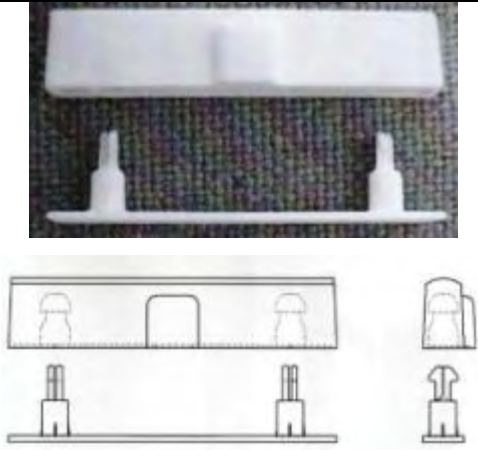
AM System: SLS
Material: Polymer
Source: EOS



<p>AM Reason 3: Consolidation Sub Category (b): Fasteners Removal Design Feature (v) : Snap fit cap feature</p> <p>Application: Electronic Enclosure Functionality Keywords: i. locating ii. assembly iii. fastening</p> <p>AM System: SLS Material: Polymer Designer : G. Gerber (MSc Thesis – Design for Rapid Manufacturing)</p>	
<p>AM Reason 3: Consolidation Sub Category (b): Remove Fasteners Design Feature (v) : Locking Groove Feature</p> <p>Application: Engine Part Functionality Keywords: i. locating ii. assembly iii. fastening</p> <p>AM System: EBM Material: Titanium Source: www.arcam.com</p>	
<p>AM Reason 3: Consolidation Sub Category (b): Remove Fasteners Design Feature (vii) : Snap fit clip feature</p> <p>Application: Functionality Keywords: i. locating ii. assembly iii. fastening</p> <p>AM System: SLS Material: Polymer Source: EOS</p>	
<p>AM Reason 3: Consolidation Sub Category (b): Remove Fasteners Design Feature (viii) : Slide opening & closing feature</p> <p>Application: Funnel Functionality Keywords: i. locating ii. assembly iii. fastening</p> <p>AM System: SLS Material: Polymer ,Source: EOS</p>	

AM Reason 3: Consolidation
Sub Category (c): Combine
Functionality
Design Feature: Multiple Elements

Application : Smoke Alarm & Bulb Holder

Functionality Keywords:

- i. Parts Consolidation
- ii. Save energy

AM System: SLS

Material: Nylon

Source: www.3trpd.co.uk



AM Reason 3: Consolidation
Sub Category (c): Combine
Functionality
Design Feature: Multiple Elements

Application: Storage & Tape dispenser

Functionality Keywords:

- i. Parts Consolidation

AM System: FDM

Material: ABS

Source: www.dimensionprinting.com



AM Reason 3: Consolidation
Sub Category (c): Combine
Functionality
Design Feature: Multiple Elements

Application : Whistle & Buckle

Functionality Keywords:

- i. Parts Consolidation

AM System: SLS

Material: Nylon

Source:
www.inventables.com/technologies/whistle-buckle



AM Reason 3: Consolidation
Sub Category: (d) Over Moulding
Design Feature: Flexible and Slip Resistance

Application (i): Tooth Brush

Functionality Keywords:

- i. External grip
- ii. Better Functionality
- iii. Ergonomics
- iv.

Material: Thermoplastic

Source : Richard Hague, Loughborough University

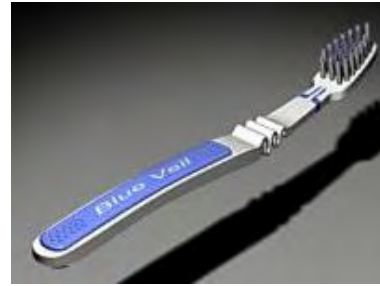

AM Reason 3: Consolidation
Sub Category: (d) Over Moulding
Design Feature: Slip Resistance

Application (ii): Razor Blade Holder

Functionality Keywords:

- i. External grip
- ii. Better Functionality
- iii. Ergonomics

Material: Thermoplastic

Source : Richard Hague, Loughborough University



AM Reason 3: Consolidation
Sub Category: (d) Over Moulding
Design Feature: Slip Resistance

Application (iii): Sat Nav

Functionality Keywords:

- i. External grip
- ii. Better Functionality
- iii. Ergonomics

Material: Thermoplastic

Source : Richard Hague, Loughborough University



AM Reason 3: Consolidation
Sub Category: (d) Integrated Damping
Design Feature: Embedded material

Application (i): Wheel
Functionality Keywords:

- i. Damping

Material: Thermoplastic
Source : Ian Campbell, Loughborough
University



APPENDIX E
AESTHETICS OR CUSTOMISED FOAM DESIGN FEATURES

AM Reason 4: Aesthetics or Form Requirement
Sub Category (a): Embossed Features
Design Feature (i): Embossed Alphabets

Application: Headphone
Functionality Keywords:

iv. Aesthetics

AM System : SLS
Material: Polymer
Source : www.freedomofcreation.com



AM Reason 2: Aesthetics or Form Requirement
Sub Category (a): Embossed Features
Design Feature (i) : Embossed Alphabets

Application: Car Door Handle

Functionality Keywords:

i. Aesthetics

AM System: SLM
Material: Metal
Source: Tom Shupe, Reid Archibald, Erik Ostler



AM Reason 4: Aesthetics or Form Requirement
Sub Category (a): Embossed Features

Design Feature (ii): Logo

Application: Logo

Functionality Keywords:

i. Aesthetics

AM System : SLS
Material: Polymer
Source : EOS



AM Reason 4: Aesthetics or Form Requirement
Sub Category (b): Surface Features
Design Feature (i): Double Mesh feature

Application: Hand Phone Cover
Functionality Keywords:

- i. Improve friction
- ii. Aesthetics

AM System: SLS
Material: Polymer
Source : www.freedomofcreation.com



AM Reason 4: Aesthetics or Form Requirement
Sub Category (b): Surface Features
Design Feature (ii): Weave feature

Application: Hand Phone Cover
Functionality Keywords:

- i. Improve friction
- ii. Aesthetics

AM System: SLS
Material: Polymer
Source : www.freedomofcreation.com



AM Reason 4: Aesthetics or Form Requirement
Sub Category (b): Surface Features
Design Feature (iii): Interlace feature

Application: Hand Phone Cover
Functionality Keywords:

- i. Improve friction
- ii. Aesthetics

AM System: SLS
Material: Polymer
Source : www.freedomofcreation.com



AM Reason 4: Aesthetics or Form Requirement
Sub Category (b): Surface Features
Design Feature (iv): Circular Array feature

Application: Place Mat

Functionality Keywords:

- i. Improve friction
- ii. Aesthetics

AM System: SLS

Material: Polymer

Source : www.freedomofcreation.com



AM Reason 4: Aesthetics or Form Requirement
Sub Category (b): Surface Features
Design Feature (vi): Fingerprint feature

Application: Ceiling Pendant

Functionality Keywords:

- i. Aesthetics

AM System: SLS

Material: Polymer

Source : www.materialise.com



AM Reason 4: Aesthetics or Form Requirement
Sub Category (b): Surface Features
Design Feature (vi): Alphabets Element

Application: Fruit Bowl

Functionality Keywords:



- i. Improve friction
- ii. Aesthetics



AM System: SLS

Material: Polymer

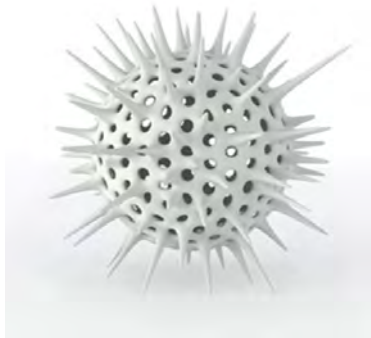
Source : Dan Yeffet



<p>AM Reason 4: Aesthetics or Form Requirement Sub Category (b): Surface Features Design Feature (vii): Lattice feature</p> <p>Application: Art Functionality Keywords:</p> <ul style="list-style-type: none"> i. Improve friction ii. Aesthetics <p>AM System: SLS Material: Polymer Source : Emmanuel Lattes</p>	
<p>AM Reason 4: Aesthetics or Form Requirement Sub Category (b): Surface Features Design Feature (viii): Spike feature</p> <p>Application: Lamps Functionality Keywords:</p> <ul style="list-style-type: none"> i. Improve friction ii. Aesthetics <p>AM System: SLS Material: Polymer Source : www.freedomofcreation.com</p>	
<p>AM Reason 4: Aesthetics or Form Requirement Sub Category (b): Surface Features Design Feature (ix): Perforated Feature</p> <p>Application: Handphone Cover Functionality Keywords:</p> <ul style="list-style-type: none"> i. Improve friction ii. Aesthetics <p>AM System: SLS Material: Polymer Source : http://goincase.com/</p>	

<p>AM Reason 4: Aesthetics or Form Requirement Sub Category (b): Surface Features Design Feature (x): Replicated element feature Application: Stool Functionality Keywords:</p> <ul style="list-style-type: none"> i. Aesthetics <p>AM System : SLS Material: Polymer Source : Assa Ashuach</p>	
<p>AM Reason 4: Aesthetics or Form Requirement Sub Category (b): Surface Features Design Feature (xi): Overlap Element feature Application: USB Shoe Functionality Keywords:</p> <ul style="list-style-type: none"> i. Improve friction ii. Aesthetics <p>AM System: SLS Material: Polymer Source : www.freedomofcreation.com</p>	
<p>AM Reason 4: Aesthetics or Form Requirement Sub Category (b): Surface Features Design Feature (xii): Twelve-sided dodecahedron feature Application: Ceiling Light Functionality Keywords:</p> <ul style="list-style-type: none"> i. Improve friction ii. Aesthetic <p>AM System: SLS Material: Nylon Source : www.materialise.com</p>	
<p>AM Reason 4: Aesthetics or Form Requirement Sub Category (b): Surface Features Design Feature (xiii): Alphabets Features Application: Holder Functionality Keywords:</p> <ul style="list-style-type: none"> i. Improve friction ii. Aesthetic <p>AM System: SLS Material: Nylon Source : http://www.shapeways.com</p>	

AM Reason 4: Aesthetics Requirement

Sub Category (c): Visual Feature

Design Feature (i): Transparent Feature

Application: Car Dashboard

Functionality Keywords:

- i. Ergonomic
- ii. Aesthetics

AM System: SLS

Material: Polymer

Source: www.materialise.com

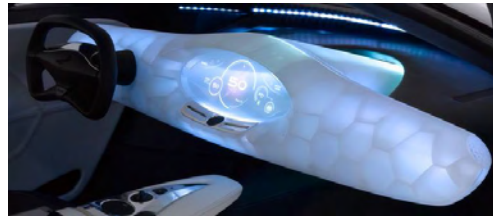

AM Reason 4: Improve Functionality

Sub Category (c): Visual Feature

Design Feature (ii): Net Shadow Effect Feature

Application: Ceiling Pendant

Functionality Keywords:

- i. Improve friction
- ii. Aesthetics

AM System: SLS

Material: Polymer

Source : Peter Jansen

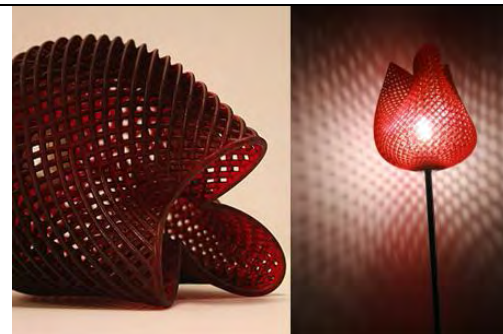

AM Reason 4: Improve Functionality

Sub Category (c): Visual Feature

Design Feature (iii): Circular Shadow Effect Feature

Application: Ceiling Pendant

Functionality Keywords:

- i. Improve friction
- ii. Aesthetics

AM System: SLS

Material: Polymer

Source : www.materialise.com

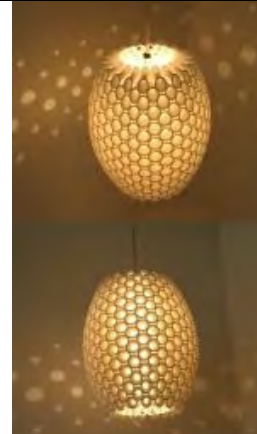

AM Reason 4: Aesthetics or Form Requirement
Sub Category (d): Customised Form
Design Feature (i): Curve feature

Application: Light

Functionality Keywords:

- iv. Aesthetics
- v. Light Weight

AM System : SLS

Material: Polymer

Source : Assa Ashuach



AM Reason 4: Aesthetics or Form Requirement
Sub Category (d): Customised Form
Design Feature (ii): Loop Feature

Application: Chair

Functionality Keywords:

- i. Aesthetics
- ii. Ergonomic
- iii. Light Weight

AM System : SLS

Material: Polymer

Source : Assa Ashuach

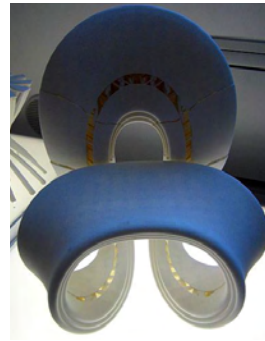

AM Reason 4: Aesthetics or Form Requirement
Sub Category (d): Customised Form
Design Feature (iii): Flame Feature

Application: Customized Air Vents

Functionality Keywords:

- i. Aesthetics
- ii. Light Weight

AM System : SLS

Material: Polymer

Source : www.sme.org

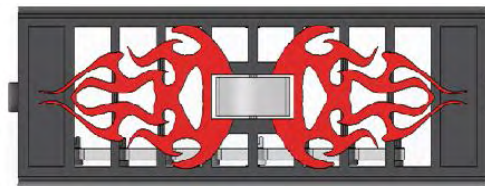

AM Reason 4: Aesthetics or Form Requirement
Sub Category (d): Customised Form
Design Feature (iv): Interlock Feature

Application: Puzzle-sculpture
Functionality Keywords:

- i. Aesthetics

AM System : SLM
Material: Metal
Source : Bathsheba Grossman



AM Reason 4: Aesthetics or Form Requirement
Sub Category (d): Customised Form
Design Feature (v): Floating Elements Feature

Application: Standing Light
Functionality Keywords:

- ii. Aesthetics

AM System : SLS
Material: Polymer
Source : www.freedomofcreation.com







AM Reason 4: Aesthetics or Form Requirement
Sub Category (d): Customised Form
Design Feature (vi): Human Body Sculpture Feature

Application: Lamp
Functionality Keywords:

- i. Aesthetics

AM System : SLS
Material: Polymer
Source : Luc Merx

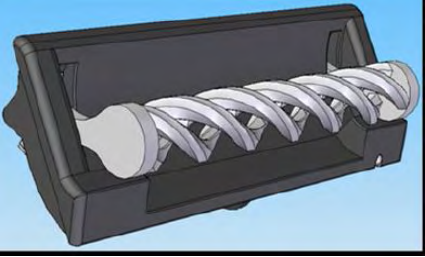

<p>AM Reason 4: Aesthetics or Form Requirement Sub Category (d): Customised Form Design Feature (vii): Fractal growth patterns of trees Application: Coffee Table Functionality Keywords:</p> <ul style="list-style-type: none"> i. Improve friction ii. Aesthetics <p>AM System: SLS Material: Polymer Source : www.iaacblog.com</p>	
<p>AM Reason 4: Aesthetics or Form Requirement Sub Category (d): Customised Form Design Feature (viii): Wave feature Application: Vase Functionality Keywords:</p> <ul style="list-style-type: none"> i. Improve friction ii. Aesthetics <p>AM System: SLS Material: Polymer Source : Hani Rashid</p>	
<p>AM Reason 2: Improve Functionality Sub Category (d): Customised Form Design Feature: Spiral Feature Application (xi): Car Door Handle Functionality Keywords:</p> <ul style="list-style-type: none"> i. Aesthetics <p>AM System: SLM Material: Metal Source: Tom Shupe, Reid Archibald, Erik Ostler</p>	
<p>AM Reason 4: Aesthetics or Form Requirement Sub Category (d): Customised Form Design Feature (x): Swept Feature Application: Fashion Functionality Keywords:</p> <ul style="list-style-type: none"> i. Aesthetics <p>AM System : SLS Material: Stainless Steel Source : Kerrie Luft</p>	

AM Reason 4: Aesthetics or Form Requirement

Sub Category (d): Customised Form

Design Feature (xi): Alphabet Form Feature

Application: Electric Guitar

Functionality Keywords:

- i. Aesthetics
- ii. Ergonomic
- iii. Light Weight

AM System : FDM

Material: ABS

Source : www.stratasys.com



AM Reason 4: Aesthetics or Form Requirement

Sub Category (d): Customised Form

Design Feature (xii): Freeform Geometry

Application: Sport

Functionality Keywords:

- i. Ergonomic
- ii. Light Weight

AM System : SLS

Material: Polymer

Designer : Olaf Diegel, Auckland University of Technology, New Zealand



AM Reason 4: Aesthetics or Form Requirement

Sub Category (d): Customised Form

Design Feature (xiii): Biomimic feature

Application: Chair

Functionality Keywords:

- i. Aesthetics
- ii. Ergonomic
- iii. Light Weight

AM System : SLS

Material: Polymer

Source : Lionel Dean, Future Factories



AM Reason 4: Aesthetics or Form Requirement
Sub Category (a): Customised Form
Design Feature (xiv): Tree roots feature

Application: Chair
Functionality Keywords:

- i. Aesthetics

AM System: SLS
Material: Polymer
Source : Sulan Kolatan and William MacDonald



AM Reason 4: Aesthetics or Form Requirement
Sub Category (a): Customised Form
Design Feature (xv): Gyroid Element

Application: Table Lamp
Functionality Keywords:

- i. Aesthetics

AM System: SLS
Material: Polymer
Source : Bathsheba Grossman

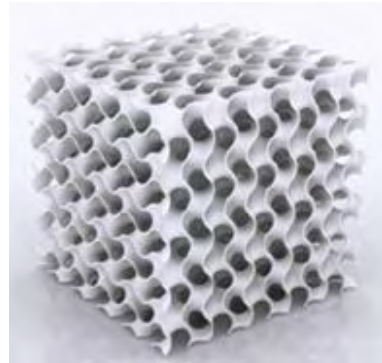

APPENDIX F
DEFINITION OF THE DESIGN FEATURES

AM Reasons of Utilisation	Application	Design Features	Description / Definition
User Fit Requirement	Sport	Body Contour Feature	Feature that represent human body shape
		Air Ventilation Feature	Feature that allow air circulation
		Hollow Studs	Customised soccer boot
		Hand Grip Contour Feature	Feature that represent human grip shape
	Medical	Ear Canal Contour	Feature that represent human ear canal shape
		Tooth Contour	Feature that represent human tooth shape
		Convex Concave Skull Contour	Feature that represent human skull shape
		Jaw Contour	Feature that represent human jaw shape
		Limb Contour	Feature that represent human limb shape
		Knee Contour	Feature that represent human knee shape
		Bone Contour	Feature that represent human bone shape
		Spinal Contour	Feature that represent human spinal shape
	Leg Contour	Feature that represent human leg shape	
	Consumer Product	Hand Grip Contour Feature	Feature that represent human grip shape
		Wrist Contour Feature	Feature that represent human wrist shape
Body Contour Feature		Feature that represent human body shape	

AM Reasons of Utilisation	Application	Design Features	Description / Definition
Improve functionality	Weight Reduction Features	Undercut	A cut made to remove material in the lower part of a product or part. It also refers to creating an overhang by cutting away material from underneath.
		Thin Wall	Wall thickness less than 2 mm
		Variable Wall Thickness	Wall thickness between 2 to 3 mm
		Selective Internal Reinforcement	Structure added on internal section of a parts or product to improve its strength
		Hollow Structure	A feature that has been removed its inner part or the core
		Honey-comb Structure	A structure consist of small hexagonal
		External Ribbing	Rib like feature to support or strengthen a part
	Increase surface friction features	Textured Surface Feature	Feature consist of textured surface
		Circular Array Feature	Feature consist of array of circular shape
		Honey Comb Feature	Feature consist of small hexagonal
	Internal Structuring Features	Internal Cable Route	Internal structure added on internal section of a parts or product to support cables etc
		Internal Flow Path	Internal structure added on internal section of a parts or product to allow air or liquid to flow
		Internal Blade Geometry	Internal geometry of blade
		Internal Cooling feature	Internal shape of a parts or product that allow air or liquid to dissipate heat
		Internal Shelving	Shelving is used for storing or allocating small stackable items within a product
		Internal Cable Support	Internal structure added on internal section of a parts or product to support cables etc
		Encapsulated Spring	A part that consist spring element
	Multiple Versions Features	Customised Thread Feature	Personalise thread to accommodate different threads dimension requirements
		Size Variation	To suit multiple user requirements such as hand size this feature could be used.

AM Reasons of Utilisation	Application	Design Features	Description / Definition
Consolidation	Fasteners Removal Features	Locking Groove	A long narrow furrow cut
		Hook Clip	Small fasteners used to hold two parts together
		Snap Fit Clip	A self-locking joint whose mating parts exert a cam action, flexing until one part slips past a raised clip on the other part, preventing their separation
		Slide Opening & Closing	Feature that move smoothly along a surface while remaining in contact with it
		Snap Fit Hook	A self-locking joint whose mating parts exert a cam action, flexing until one part slips past a raised hook on the other part, preventing their separation
		Mounting Boss	A circular rounded projection or protuberance
		Snap Fit Hook	A self-locking joint whose mating parts exert a cam action, flexing until one part slips past a raised hook on the other part, preventing their separation
	Instant Assemblies Features	Multiple Link Feature	Features that linked in series
		Living Hinge Feature	Feature used to connect two parts and keep them together while allowing them to open and close.
		Foldable Feature	Feature that could be folded
		Torus Feature	Feature consisting of a ring with a circular cross-section
		Interconnected Feature	Feature that connected to each other
		Gyroid Feature	A feature that connected triply periodic minimal surface
		Tree Root Feature	The pattern of a tree root
		Encapsulated Spring Lock Feature	Feature that utilises spring for locking purpose
		Encapsulated Track & Ball Feature	Feature that consist a spiral track & ball
		Slide Feature	A feature that allow free left & right sliding action
		Circular Living Hinge	A joint feature that capable of being folded up
		Foldable Living Hinge	A joint feature that capable of being folded up
		Integrated Ball & Socket Feature	Feature that being composed and coordinated to form a whole
		Internal Hinged Button Feature	A push button made that connects two solid objects
		Enclosed Volume	A rigid covering that envelops a part or

		Feature	product
		Ready Assembled Gear	Gears that fit together to form a self-contained unit
		Interwoven Features	Feature that combine links through weaving
		Encapsulated Bearing	Ball bearing that has been enclosed in the housing
		Ball & Socket feature	A press fit joint feature that prevent their separation but allow free movement
		Self Centring Feature	Features that resume the centre position when the lock is close
		Interlock Feature	Feature that engaged or intermeshed with one another
	Multiple Functional Parts	Multiple Elements	A product that has more than one functions
	Over moulding	Over Moulding	A feature included to improve surface friction

AM Reasons of Utilisation	Application	Design Features	Description / Definition
Aesthetics or Form Requirement	Embossed Features	Embossed Alphabets	Element of ideogram, symbol, emblem, icon, sign etc
		Logo	symbol, icon, sign etc
	Surface Features	Double Mesh Feature	Pattern of weaving
		Weave Feature	Pattern of weaving
		Interlace Feature	Pattern of weaving
		Circular Array Feature	An orderly arrangement of circular shape
		Fractal Growth Feature	A rough or fragmented geometric shape that can be split into parts
		Fingerprint Feature	Pattern of finger impression
		Alphabets Element	Feature that includes letters and numbers
		Lattice Feature	Arrangement in a regular periodic pattern
		Spike Feature	Pattern of a sharp rise
		Perforated Feature	Regularly spaced and accurately shaped holes which are punched throughout the length
		Replicated Feature	A pattern that being repeated
		Overlapping Feature	A pattern that being overlapped
	Twelve-sided dodecahedron feature	Polyhedron having twelve plane faces	
	Visual Features	Transparency / Translucency feature	Feature of being clear or transparent
		Net Shadow Effect Feature	Feature that provide net shadow effect
		Circular Shadow Effect Feature	Feature that provide circular shadow effect
	Customised Form Features	Curve Feature	Pattern that causes the formation of a curvature
		Loop Feature	A round shape geometry
		Organic Form	Shape that mimics nature
		Flames Feature	Pattern of flames
		Growth patterns of trees	Pattern that mimic tree root
		Floating Element Feature	Pattern or shape suspended in air
		Human Body Sculpture feature	Pattern or human body attached and suspended in air
		Wave Feature	Shape of a ridges that moves across the surface of a liquid
		Spiral Feature	A curve surface that lies on the surface of a cylinder or cone and cuts the element at a constant angle
		Swept Feature	A feature that variant of a wireframe
		Free form Geometry	Irregular shape or not formed according to any present rules or standard design
		Bio mimic Feature	Pattern development that mimics nature
	Interwoven Form	Linked or locked closely together	

APPENDIX G

QUESTIONNAIRE FEEDBACK TO VALIDATE DfAM FEATURE DATABASE

Synopsis:

The aim of this questionnaire is to validate the overall effectiveness, the content and the usability of the design for additive manufacturing (DfAM) feature database supplied with the product design exercise. The information included in this questionnaire will only be reproduced in an anonymous manner and it will only be used to carry out the research stated above.

A. Contact Data:

Name: Nikolaos Ovvadias

Course: MSc User Centred Product Design (Completed 2011)

B. What part or product have reverse engineered for this exercise?

Juice Extractor

C. Please tick the relevant box and provide additional information if necessary to the questions below.

1. How do you generally feel about the effectiveness of DfAM feature database?

1. Very Poor 2. Poor 3. Neutral 4. Good 5. Excellent
-

Other Comments: _____

2. How do you rate the pictorial data and textual content of the database?

1. Very Poor 2. Poor 3. Neutral 4. Good 5. Excellent
-

Other Comments: _____

3. How do you rate the tool's approach that provides examples of design features that could be incorporate or added into you design work?

1. Very Poor 2. Poor 3. Neutral 4. Good 5. Excellent

<input type="checkbox"/>	<input type="checkbox"/>	<input type="checkbox"/>	<input checked="" type="checkbox"/>	<input type="checkbox"/>
--------------------------	--------------------------	--------------------------	-------------------------------------	--------------------------

Other Comments: _____

4. How do you rate the usability of the database in order to impart possible design features in product design for AM?

1. Very Poor 2. Poor 3. Neutral 4. Good 5. Excellent

<input type="checkbox"/>	<input type="checkbox"/>	<input checked="" type="checkbox"/>	<input type="checkbox"/>	<input type="checkbox"/>
--------------------------	--------------------------	-------------------------------------	--------------------------	--------------------------

Other Comments: _____

5. Does the database provide aid to understand the design freedom of AM?

	1	2	3	4	5	
No, not at all	<input type="checkbox"/>	<input type="checkbox"/>	<input type="checkbox"/>	<input type="checkbox"/>	<input checked="" type="checkbox"/>	Yes, very much so

Other Comments: _____

6. Does the database help to enhance your design creativity?

	1	2	3	4	5	
No, not at all	<input type="checkbox"/>	<input type="checkbox"/>	<input type="checkbox"/>	<input checked="" type="checkbox"/>	<input type="checkbox"/>	Yes, very much so

Other Comments: _____

7. Does your product design influenced when using the database?

	1	2	3	4	5	
No, not at all	<input type="checkbox"/>	<input type="checkbox"/>	<input type="checkbox"/>	<input checked="" type="checkbox"/>	<input type="checkbox"/>	Yes, very much so

Other Comments: _____

8. Do you have any suggestion how the DfAM feature database could be improved?

Bigger Images

Synopsis:

The aim of this questionnaire is to validate the overall effectiveness, the content and the usability of the design for additive manufacturing (DfAM) feature database supplied with the product design exercise. The information included in this questionnaire will only be reproduced in an anonymous manner and it will only be used to carry out the research stated above.

C. Contact Data:

Name:.....Virginia Zhang.....
Course: ...PhD in Design School.....

D. What part or product have reverse engineered for this exercise?

Beard Shaver

C. Please tick the relevant box and provide additional information if necessary to the questions below.

1. How do you generally feel about the effectiveness of DfAM feature database?

6. Very Poor	7. Poor	8. Neutral	9. Good	10. Excellent
<input type="checkbox"/>	<input type="checkbox"/>	<input type="checkbox"/>	<input type="checkbox"/>	<input checked="" type="checkbox"/>

Other Comments: It provides brilliant inspirations systematically

2. How do you rate the pictorial data and textual content of the database?

6. Very Poor	7. Poor	8. Neutral	9. Good	10. Excellent
<input type="checkbox"/>	<input type="checkbox"/>	<input type="checkbox"/>	<input checked="" type="checkbox"/>	<input type="checkbox"/>

Other Comments: _____

3. How do you rate the tool's approach that provides examples of design features that could be incorporate or added into you design work?

6. Very Poor 7. Poor 8. Neutral 9. Good 10. Excellent

<input type="checkbox"/>	<input type="checkbox"/>	<input type="checkbox"/>	<input checked="" type="checkbox"/>	<input type="checkbox"/>
--------------------------	--------------------------	--------------------------	-------------------------------------	--------------------------

Other Comments: _____

4. How do you rate the usability of the database in order to impart possible design features in product design for AM?

6. Very Poor 7. Poor 8. Neutral 9. Good 10. Excellent

<input type="checkbox"/>	<input type="checkbox"/>	<input type="checkbox"/>	<input type="checkbox"/>	<input checked="" type="checkbox"/>
--------------------------	--------------------------	--------------------------	--------------------------	-------------------------------------

Other Comments: Easy to have access and easy to use

5. Does the database provide aid to understand the design freedom of AM?

	1	2	3	4	5	
No, not at all	<input type="checkbox"/>	<input type="checkbox"/>	<input type="checkbox"/>	<input checked="" type="checkbox"/>	<input type="checkbox"/>	Yes, very much so

Other Comments: Add links of detailed information for more professional users

6. Does the database help to enhance your design creativity?

	1	2	3	4	5	
No, not at all	<input type="checkbox"/>	<input type="checkbox"/>	<input type="checkbox"/>	<input type="checkbox"/>	<input checked="" type="checkbox"/>	Yes, very much so

Other Comments: _____

7. Does your product design influenced when using the database?

	1	2	3	4	5	
No, not at all	<input type="checkbox"/>	<input type="checkbox"/>	<input type="checkbox"/>	<input checked="" type="checkbox"/>	<input type="checkbox"/>	Yes, very much so

Other Comments: _____

8. Do you have any suggestion how the DfAM feature database could be improved?

Could develop images and features to keep the database up-to-date

Synopsis:

The aim of this questionnaire is to validate the overall effectiveness, the content and the usability of the design for additive manufacturing (DfAM) feature database supplied with the product design exercise. The information included in this questionnaire will only be reproduced in an anonymous manner and it will only be used to carry out the research stated above.

E. Contact Data:

Name: Abby Paterson

Course: PhD – Refinement of a CAD workflow for a specific medical application

F. What part or product have reverse engineered for this exercise?

A cold-sore wand – the product emits red light to stimulate cell regrowth to speed up the healing process. My work was a re-design of an existing product that had several flaws.

C. Please tick the relevant box and provide additional information if necessary to the questions below.

1. How do you generally feel about the effectiveness of DfAM feature database?

11. Very Poor 12. Poor 13. Neutral 14. Good 15. Excellent

Other Comments: Potentially very helpful for designers who are less familiar with AM.

2. How do you rate the pictorial data and textual content of the database?

11. Very Poor 12. Poor 13. Neutral 14. Good 15. Excellent

Other Comments: The information given in each category was very vague and very

limited. It might have been a good idea to include a description/synopsis of each profile and each image, showing how SLS had been used for their specific design process (maybe have 'before' and 'after' illustrations where applicable). In addition, the overmolding image was misleading, as I thought this part had been made with the Objet Connex machine. I could not understand the link between SLS and overmolding for the example given. The image for 'internal structuring' was also very pixelated, and it was difficult to understand the part.

3. How do you rate the tool's approach that provides examples of design features that could be incorporate or added into you design work?

11. Very Poor 12. Poor 13. Neutral 14. Good 15. Excellent

<input type="checkbox"/>	<input type="checkbox"/>	<input type="checkbox"/>	<input checked="" type="checkbox"/>	<input type="checkbox"/>
--------------------------	--------------------------	--------------------------	-------------------------------------	--------------------------

Other Comments:

4. How do you rate the usability of the database in order to impart possible design features in product design for AM?

11. Very Poor 12. Poor 13. Neutral 14. Good 15. Excellent

<input type="checkbox"/>	<input type="checkbox"/>	<input type="checkbox"/>	<input checked="" type="checkbox"/>	<input type="checkbox"/>
--------------------------	--------------------------	--------------------------	-------------------------------------	--------------------------

Other Comments: **Very easy to use.**

5. Does the database provide aid to understand the design freedom of AM?

	1	2	3	4	5	
No, not at all	<input type="checkbox"/>	<input type="checkbox"/>	<input checked="" type="checkbox"/>	<input type="checkbox"/>	<input type="checkbox"/>	Yes, very much so

Other Comments: **Referring back to the comments made in question 2; I think each profile should have some text explaining more examples or applications in more detail. Again, I think my knowledge of AM will bias the result I have given, compared to someone who has no prior knowledge, but I think more explanation of each profile would definitely be a good idea.**

6. Does the database help to enhance your design creativity?

	1	2	3	4	5	
No, not at all	<input type="checkbox"/>	<input type="checkbox"/>	<input checked="" type="checkbox"/>	<input type="checkbox"/>	<input type="checkbox"/>	Yes, very much so

Other Comments: I found that my re-design was hindered, but that's due to the limitations of SLS (i.e. opaque material) and the needs/constraints of the product, not the database.

7. Does your product design influenced when using the database?

	1	2	3	4	5	
No, not at all	<input checked="" type="checkbox"/>	<input type="checkbox"/>	<input type="checkbox"/>	<input type="checkbox"/>	<input type="checkbox"/>	Yes, very much so

Other Comments: Again, a limitation of SLS, not the database. I should have re-designed something with more scope for abstract styling, and with less concerns over hygiene (I would have liked to have integrated a lattice-type structure or a more textured surface into the design for aesthetic purposes, but such structures harbour bacteria which could lead to infection if applied to a cold sore).

8. Do you have any suggestion how the DfAM feature database could be improved?

It would be great if it catered for all AM technologies, i.e. the capabilities of the Objet Connex family, such as multi-material builds, colour options, and the ability to create transparent parts.

Synopsis:

The aim of this questionnaire is to validate the overall effectiveness, the content and the usability of the design for additive manufacturing (DfAM) feature database supplied with the product design exercise. The information included in this questionnaire will only be reproduced in an anonymous manner and it will only be used to carry out the research stated above.

G. Contact Data:

Name: Lingjing Li

Course: Msc Industrial Design, Loughborough University (Completed 2011)

H. What part or product have reverse engineered for this exercise?

Hand Held Blender

C. Please tick the relevant box and provide additional information if necessary to the questions below.

1. How do you generally feel about the effectiveness of DfAM feature database?

16. Very Poor 17. Poor 18. Neutral 19. Good 20. Excellent

Other Comments: It inspires me to think new ideas that exclude traditional manufacture ways.

2. How do you rate the pictorial data and textual content of the database?

16. Very Poor 17. Poor 18. Neutral 19. Good 20. Excellent

Other Comments: _____

3. How do you rate the tool's approach that provides examples of design features that could be incorporate or added into you design work?

16. Very Poor 17. Poor 18. Neutral 19. Good 20. Excellent

<input type="checkbox"/>	<input type="checkbox"/>	<input type="checkbox"/>	<input type="checkbox"/>	<input checked="" type="checkbox"/>
--------------------------	--------------------------	--------------------------	--------------------------	-------------------------------------

Other Comments: _____

4. How do you rate the usability of the database in order to impart possible design features in product design for AM?

16. Very Poor 17. Poor 18. Neutral 19. Good 20. Excellent

<input type="checkbox"/>	<input type="checkbox"/>	<input type="checkbox"/>	<input type="checkbox"/>	<input checked="" type="checkbox"/>
--------------------------	--------------------------	--------------------------	--------------------------	-------------------------------------

Other Comments: _____

5. Does the database provide aid to understand the design freedom of AM?

	1	2	3	4	5	
No, not at all	<input type="checkbox"/>	<input type="checkbox"/>	<input type="checkbox"/>	<input checked="" type="checkbox"/>	<input type="checkbox"/>	Yes, very much so

Other Comments: _____

6. Does the database help to enhance your design creativity?

	1	2	3	4	5	
No, not at all	<input type="checkbox"/>	<input type="checkbox"/>	<input type="checkbox"/>	<input checked="" type="checkbox"/>	<input type="checkbox"/>	Yes, very much so

Other Comments: _____

7. Does your product design influenced when using the database?

	1	2	3	4	5	
No, not at all	<input type="checkbox"/>	<input type="checkbox"/>	<input type="checkbox"/>	<input checked="" type="checkbox"/>	<input type="checkbox"/>	Yes, very much so

Other Comments: _____

8. Do you have any suggestion how the DfAM feature database could be improved?

Add more design features

APPENDIX H
LIST OF PAPER PUBLISHED

Paper A:

Maidin S., Campbell R.I., Drstvensek I. and Sever P. (2009) *Design for Rapid Manufacturing - Capturing Designers' Knowledge*, 4th International Conference on Advanced Research in Virtual and Rapid Prototyping (VRAP 2009), Leiria, Portugal.

Paper B:

Maidin S., Campbell R.I., (2009) *Rapid Manufacturing: What are the Issues of Student Designers?*, 10th Annual International Conference On Innovative Rapid Product Development, (RAPDASA 2009) East London, Mpekweni Beach Resort.

Paper C:

Maidin S., Campbell R.I., (2010) *Development of a Feature Repository to Support Design for Additive Manufacturing (DfAM)*, 3rd International Conference on Additive Technologies (iCAT2010), Nova Gorica, Slovenia.

Journal paper currently being reviewed (Journal of Assembly Automation):

Maidin S., Campbell R.I., (2011) *Development of a Design Feature Database to support Design for Additive Manufacturing (DfAM)*.