

# Evolution of Maintenance Strategies in oil and Gas Industries: The Present Achievements and Future Trends.

Jeremiah Eyoh

*Electrical, Electronics and Systems Engineering  
AVRRC Research Group  
Loughborough University, Loughborough, UK  
j.e.eyoh@lboro.ac.uk*

Roy S. Kalawsky

*Electrical, Electronics and Systems Engineering  
AVRRC Research Group  
Loughborough University, Loughborough, UK  
r.s.kalawsky@lboro.ac.uk*

**Abstract** – Engineering Systems maintenance and reliability challenges have drawn serious attention of researchers and industrialists all over the world due to continuous evolution, innovation and complexity of modern technologies deployed in manufacturing and production systems. These systems need very high reliability and availability due to business, mission and safety critical nature of their operations. This paper reviews evolution of systems or equipment maintenance strategies practiced over the years in complex industrial and manufacturing systems such as oil and gas production systems, satellite communication system, spacecraft navigational system, nuclear power plants, etc. The paper also examines the current maintenance and reliability philosophies, their limitations and highlights major breakthroughs and achievements with regards to complex engineering systems maintenance. Intelligent maintenance, a novel approach to complex engineering systems maintenance and reliability sustainment is proposed. The proposed approach reintegrates operation and maintenance phase into system development life cycle, adopts advanced engineering tools and methodology in developing condition-based predictive maintenance, an intelligent maintenance system with resilient, autonomous and adaptive capabilities. Application of Neural network approach to multi-sensor data fusion for condition-based predictive maintenance system is briefly presented.

**Keywords** – Availability, evolution, interactions, Intelligent maintenance, maintainability, maintenance techniques, neural network, oil and gas, reliability, risks, sensor fusion, safety.

## I. INTRODUCTION

Maintenance can basically be seen as a function to keep a tool, machine, or system (simple or complex), in a working condition by proper usage, repairing broken part or component, or replacing some of the broken parts such that it is available and fit for the designed purpose whenever the need arises. This primitive definition of maintenance simplifies and links the concept of maintenance to ancient farmers and builders when they started deploying simple machines to enhance and facilitate their nascent professions. Thus the concept of maintenance is traceable to the inception of simple tools and machines. The evolving nature of maintenance philosophy has always been in *pari-passu* with the ever changing technological innovations in designing simple machines and equipment which have presently metamorphosed to complex, sophisticated and indispensable systems. In those days, machine and equipment designers did not consider the issue of maintainability in the course of designing these simple,

mechanical systems. Emphasis was particularly on durability, robustness and simplicity.

In oil and gas industries, the trend was not different, despite the high level of risks associated with processes and operations of the systems. The simple production plants were mainly made up of mechanical, pneumatic, hydraulic systems and basic electrical power generation equipment. This made the impact of failure of these systems with regards to volatile nature of the processes, very colossal. There were no stringent local and international standards and regulatory requirements and their compliance were not enforced and followed up by the regulatory bodies.

Inadequate maintenance and safety procedures have always been the major cause of catastrophic incidents and accidents in the oil and gas industries, for instance, the Piper Alpha gas explosion in 1988 [1]. The recent developments and technological advances in the oil and gas subsector further highlight the need for creative, resilient and adaptive, total-asset-lifecycle maintenance management solutions [2].

Effective maintenance practices and techniques reduce the risk of catastrophic failures, minimize maintenance costs, maximize system availability, increase productivity and enhance or sustain reliability of the production system. Maintenance is a key cost driver in oil and gas industries, thus an important area to focus research and development efforts on [3]. In [4] certain objectives, as applied to oil and gas production systems, such as prevention of breakdown during operation, identification and elimination of systems' inherent hazards, elimination or mitigation of environmental impacts in the course of operations are integral part of operational procedure. Other benefits of effective maintenance practice are optimization of maintenance resources, increase in system availability and productivity and slow rate of system degradation.

Maintainability of engineering systems or equipment is basically a concept that should be considered from the requirement and design phases to implementation (installation) phase of system development. In most industrial systems or subsystems, components layout and physical structuring will confirm that maintainability was the least considered during the design phase of these systems. The concept of maintainability should be closely related to the characteristic of system or equipment design and installation [4]. It is one of the designed parameters for the purpose of minimizing repair time and cost of operations and maintenance [5].

In line with the emerging nature of modern engineering systems, maintenance of these systems should continue to inevitably evolve with the same pace with technology to cope with complexity and emerging behaviours. This paper fully and actively integrates operations and maintenance phase into systems development life cycle to model an integrated system development life cycle that is capable of facilitating intelligent maintenance solution. This maintenance strategy deploys model based systems engineering and data analytic approaches to develop condition-based predictive maintenance, an intelligent and reliability solution. The proposed maintenance system utilizes plant information to monitor health condition of the system, detect fault at incipient stage, diagnose the failing components and predict the remaining useful life of the system using failure trajectories of the components. Neural network (NN) has been used by researchers recently for multi-sensor data fusion (MSDF), estimation and prediction of systems' state. This paper will briefly apply NN technique of data fusion to monitor, fuse seventeen temperature sensors data and estimate the output temperature of the gas turbine engine - the key component of oil and gas processing system.

## II. EVOLUTION OF INDUSTRIAL MAINTENANCE STRATEGIES IN OIL AND GAS SUBSECTOR

Maintenance Strategies during industrial history have witnessed, according to [6], progressive evolution and it is presently an on-going process. Maintenance of simple tools and machines has been in existent with mankind ever since man began to utilize these basic and primitive tools to enhance their farming and building professions. In oil and gas production plants, these devices are pneumatic switches, transmitters, valves and pumps. They are limited in their functions and usefulness. Maintenance of these devices was performed when they failed completely, and this rarely happened due to the durability and simplicity of the systems. This maintenance practice is the called primitive maintenance philosophy. A typical example is the unplanned or breakdown maintenance which is reactive maintenance program, whereby the system is run till it breaks down before the maintenance actions are taken. The industrial systems were operated until they failed, at which point they were either repaired or replaced; 'Fix it when it fails or breaks' [6]. Breakdown maintenance was the generic maintenance approach, which is described as a reactive maintenance where no action is taken to prevent system failures or to detect the onset of failures. The primitive maintenance approach was on demand basis, mostly when there is catastrophic failure [6], [7]. Due to impacts of industrial on world economy, this maintenance ideology seems to disappear from the scene after the Second World War. [8]

The need for sophisticated and complex production system paved the way for industrial and technological evolution during the Second World War. The war drastically change the scenario explained above because there was obvious pressure for high quality products and services of all types, especially in department of defence and energy sector [8]. This situation forced the industrialist to reluctantly and weakly integrate maintenance concept with production operations. Though not

completely an isolated activity, the traditional maintenance was viewed as a technical matter, which is in conflict with the fundamental objectives of most of the organizations.

The traditional maintenance concept considers immediate reduction in maintenance cost with little or no regards to system's reliability and availability. At earlier stages the Corrective Maintenance strategy was practiced in the industries [9], which later evolved to Preventive Maintenance (PM) [10], [11]. PM was a proactive maintenance strategy which focuses on taking actions before the failure occurs. This was owed to high competitiveness in oil and gas industries. Emergence of engineering concepts such as reliability, maintainability, availability and cost optimization during operations and maintenance phase of system lifecycle were the wake-up calls to the management of the industries to reduce equipment downtime in order to remain in business. This concern led to the thinking that equipment failure could be avoided if certain preventive measures are incorporated into the production operations. Thus, the concept of preventive or scheduled (planned) maintenance was formed, accepted and practiced. These traditional maintenance approaches evolved to modern maintenance techniques such as Condition Based Maintenance (CBM) [3] [7] [12], where the decisions are made based on the machine conditions obtained through measurement systems. Figure 1.0 shows the evolution of industrial systems maintenance practices, indicating how it started with primitive "run-to-failure or reactive maintenance philosophy.

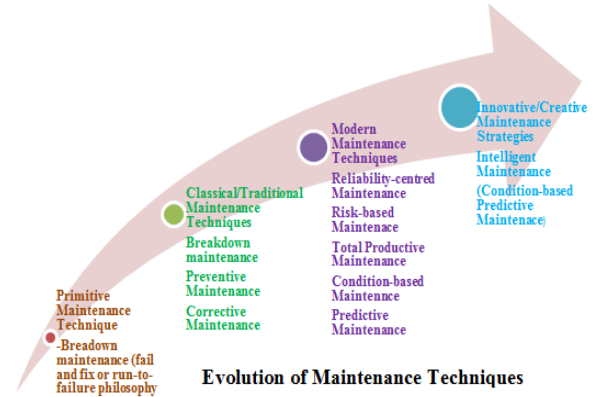

Fig 1: Evolution of industrial systems maintenance practices.

### A. Breakthroughs and Achievement in Modern Maintenance Programs

Prior to the introduction and integration of computers with industrial control applications, manufacturing and production operations between late 1970's and early 1980's, the standard or prevalent control system consisted of several number of single-loop analogue controllers (mostly electromechanical, pneumatic and hydraulic), where signals were not readily available to operators [13]. Other field devices were relays, contactors, pneumatic actuators, valves and pumps. Due to obvious limitations of electromechanical and pneumatic control systems, there was an urgent necessity to replace this primitive system with computer-based control systems to cope with the increasing complex, advanced and sophisticated oil and gas

production plants and innovative processes. Maintenance of these systems was a progressive challenge, which was more evident as the modern technologies continue to evolve and more sophisticated in response to new operational demands in a variety of rugged oil and gas industries around the world [2]. This affected the designed reliability, resulting in frequent unplanned outages, low productivity and increasing rate of overall systems degradation.

The search or quest for effective maintenance practices leads to modern maintenance programs which utilize functional and operational information from the system and also manufacturer's data to develop maintenance model with regards to the condition of the equipment or system and the overall life cycle of the system.

A typical modern maintenance program attempts to optimize traditional maintenance practices, incorporate condition assessment of the equipment, historical information and other best practices. These maintenance programs include: *Reliability-Centered Maintenance (RCM)* which establishes the functional requirement and the desired performance standards of equipment or system and these are then related to design and inherent reliability parameters of the system or equipment [4]. Generally, RCM is a systematic approach that seeks to harmonize a facility's equipment and resources with respect to operational and maintenance needs such that a high degree of system's reliability and cost-effectiveness are achieved. *Risk-Based Maintenance (RBM)* involves planning of an inspection on the basis of the information obtained from a risk analysis of equipment. The inspection is designed to detect potential degradation before fitness-for-service could be threatened [14]. Some versions of risk-based maintenance focus firstly on equipment, and then its operational context, failure modes, probability of failure, consequences and maintenance requirements [15]. The primary aim of RBM is optimization of maintenance resources. *Total Productive Maintenance (TPM)*, was first initiated in Japan as a development or optimization of preventive maintenance after passing through various stages of iterations [16]. These development stages included integration and application of breakdown maintenance, reliability and maintainability concept with respect to economic efficiency in industrial system design [4]. The TPM aims at overall system efficiency. Thus system or equipment efficiency is a function of three factors mentioned in [16], [17]: availability or uptime of the system, performance efficiency and effectiveness and productivity and rate of quality output.

Another breakthrough in modern maintenance practices is the *Condition-Based Maintenance (CBM)*, developed by considering current degradation and its evolution [18]. CBM is defined as Maintenance carried out according to need as indicated by condition monitoring system [3] [7]. CBM involves system or equipment critical parameters monitoring to detect deviations from the normal system's operation. CBM allows the lowest cost and most effective maintenance program by determining the correct activity and resources at the correct time [19]. *Predictive maintenance (PdM)* program is based on the actual conditions or trends of the systems or equipment. The PdM considers the health state of the system or equipment

using critical parameters, compares it with the designed or reference performance profile, forecasts the future health state of the system using observed deviations and issues maintenance management decision for effective maintenance program and actions. Properly implemented PdM can identify most, if not all, factors that limit effectiveness and efficiency of the entire production system or plant [12], [18].

### B. Limitations of Traditional and Modern Maintenance Programs

The advances and evolution of industrial technologies paved the way to the inception of automation of industrial systems, thus making the limitations and weakness of the modern maintenance paradigms more visible. These necessitated the search for effective and adequate maintenance strategies to cope with the progressively increasing complexity and sophistication of modern industrial systems. The development and adoption of effective maintenance practices and techniques are driven by the desire to reduce the risk of catastrophic failures, minimize maintenance costs, maximize system availability, and sustain engineering systems' reliability [3], [20].

Apart from high cost of modern and complex industrial systems maintenance, other limitations of traditional and modern maintenance strategies are as follows;

- Correlational faults of the system are not addressed
- Ineffective to deal with novel fault due to emergent behaviour of the complex systems
- Faults are possibly introduced into the systems in the course of the maintenance activities
- Most CBM and PdM programmes add both structural and functional complexities to the already complex system due to hardware installed or integrated to the extant systems. This tends to impact on the cost of maintenance and reduce reliability of the system.
- Little or no integration of process system condition monitoring and failure prognosis with extant maintenance programmes.
- Most existing maintenance practices seem to alienate operation and maintenance phase of system development from the system's life-cycle.
- Human factors are not effectively integrated into the design of maintenance management system.

## III. SYSTEM DESIGN FOR RELIABILITY AND MAINTAINABILITY

The search for optimal solutions to reliability and maintenance challenges in oil and gas industries leads to the discovery that system reliability and maintainability (R&M) are design parameters which must be considered from concept phase to the final phase of System development life-cycle (SDLC). Thus, a poorly designed system in terms of R&M makes nonsense of any creative and effective maintenance practices. Therefore the foundation of effective and adaptive maintenance

strategy is the design for reliability and maintainability (DFR&M). Design for Reliability (DFR) defines the set of tools and techniques used to facilitate product and process development to ensure that customer's requirements and expectations for reliability are fully met throughout the life of the product with lowest possible overall life-cycle costs. Its success lies with reliability engineering tools, and effective utilization of tools throughout the SDLC. The traditional SDLC model does not consider operations and maintenance (O&M) as a phase in the life cycle model. Also each phase does not have a clear feedback structure to the previous phase nor O&M phase which embodies the purpose and functions of the designed product or service. Shown below are the traditional SDLC and integrated SDLC models in figures 2 and 3 respectively.

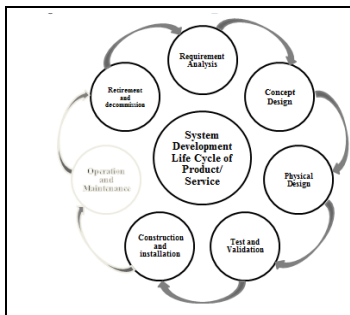

Figure 2: Traditional SDLC Model

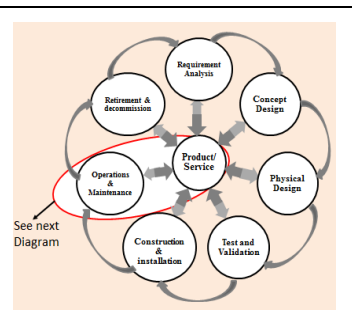

Figure 3: Integrated SDLC Model

The integrated SDLC deploys model-based systems engineering methodology to develop product, the pivot of the SDLC which interacts with every phase of the system development throughout the life-cycle of the product or service. This research focuses on the O&M phase of the SDLC model as highlighted in Figure 3 and exploded diagram of DFR&M model in Figure 4.

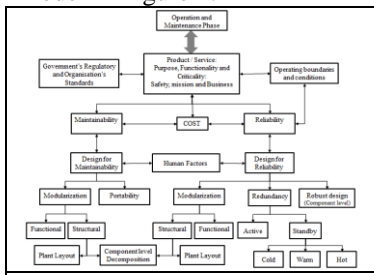

Figure 4: Architecture of DFR&M Model

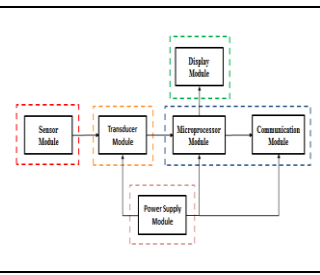

Figure 5: Architecture of CLM of smart transmitter

Several approaches have been adopted by designers to ensure higher R&M of complex systems. These include modularization, redundancy and robust design at components level. Maintainability is the probability of performing a successful repair action within a given time. It measures the ease and speed with which a system can be restored to operational status after a failure occurs. Maintainability is a function of mean time-to-repair (MTTR), while reliability is a function of mean time-to-failure (MTTF), for non-repairable components or mean time between failures (MTBF), for repairable components. The relationship between system's

reliability and maintainability lies with the availability of the system as given by the equation below:

$$A_i = \frac{MTBF}{MTBF + MTTR} \times 100 \quad (1)$$

Where  $A_i$  is inherent availability, MTBF is a function of designed reliability while MTTR is a function of designed maintainability.

Reliability, availability and maintainability (RAM or RMA) are system design attributes that have significant impacts on the sustainment or total life cycle costs (LCC) of a developed system. Additionally, the RAM attributes impact the ability to perform the intended mission and affect overall mission success. The standard definition of reliability is the probability of zero failures over a defined time interval (or mission), whereas availability is defined as the percentage of time a system is considered ready to use when tasked. Maintainability is a measure of the ease and rapidity with which a system or equipment can be restored to operational status following a failure.

#### A. Modularization of complex system for higher R&M

Modularization, from engineering perspective, has the following advantages [20],[21]; it helps in managing complexities, it enhances parallel processing, it eases implementation of intelligent maintenance, improves systems reliability and availability, and it accommodates future uncertainty and change given that systems maintenance strategies have close relationship with their designs. Many advanced engineering tools and techniques are available for structural and functional modularization, such as design structure matrix (DSM). The DSM gives a simple, compact, and visual representation of a complex system that supports creative solutions to decomposition and integration problems [22]. The DSM is used to model the structure of complex systems or processes, in order to perform system analysis, project planning and products development. The DMS lists all constituent sub-systems or activities and the corresponding information exchange, interactions and dependency patterns modularization methods. Modularization techniques that are useful in complex system analysis include function structure heuristics, DSM [23], modular function deployment (MFD) [23], axiomatic design [24], [25] and domain matrix mapping (DMM) [26]. Effective implementation modularization approaches such as MFD, DSM and DMM facilitates systems reliability optimization. In structural decomposition, the level decomposition or the size of the subsystems must be strictly considered, as this may affect the architectural analysis of the results and data structuring during pre-processing stage of data analysis. Structural decomposition to components level has positive impacts on R&M of the system; that is reduction in MTTR and cost of maintenance. Figure 5 shows the architecture of components level modularization (CLM) of a smart field transmitter commonly used in oil and gas production plants. (figure 5 here)

### B. Redundancy in Complex system design for Higher R&M

Fault-tolerant or resilient system is the ability of a system to continue to perform its designed functions even when some components or subsystems have failed. Resilient or fault tolerant system is a reliable system. Redundancy is the most commonly used approach to achieving fault-tolerant design of complex and critical systems. Redundancy is the duplication or triplication of critical components or function of the system with intension of making the system fault-tolerant and maximising reliability of the system. Redundancy could be active or standby (may be cold, warm or hot standby). The choice of redundancy depends on the criticality of the system. For quality product through DFR&M principles, the purpose and functions of the product (which embodies criticality – business, mission and safety), must be the focal points of the designers at every phase of SDLC. This helps the designers to define desired reliability from the component, subsystem and to the system level, and also facilitates enhanced solutions to redundancy allocation and reliability optimization problems. The redundancy allocation techniques include exact methodology of reliability optimization of series-parallel systems using genetic algorithm (GA) [27], heuristic and meta-heuristic techniques using a two-phase linear programming approach for reliability allocation problem (RAP) [28], a variable neighbourhood algorithm (VNA) for RAP in series-parallel systems [29] and a multi-level redundancy optimization in series systems [30]. Khalili and Amiri in [31] proposed an efficient epsilon-constraint method for solving multi-objective redundancy allocation problems. Mostafa et al in [32] uses mixed strategy of redundancy allocation problem that is a combination of traditional active and standby strategies, Srinivasa Rao and Naikan in [33] combined Markov approach with system dynamics simulation approach to study the reliability of a repairable system with standby redundancy strategy. Thus systems R&M are very important to both researchers and industrialists, and there are lots of research and development opportunities in the areas.

### C. Human Factors/Interface

A system, irrespective of complexity, interfaces with human for completeness and effectiveness. Systems designed by human are operated by human and for the benefit of human. In SDLC, human factors are very crucial at every phase of the product/service life-cycle. For higher availability and productivity of any system, human factors must be seriously considered during the course of system DFR&M. The diagram in Figure 4 and 7 highlight how critical human factors are during SDLC. This research is proposing intelligent maintenance system which is achieved when human factors are effectively interfacing with maintenance procedure/process and the complex plant/system.

## IV. INTELLIGENT MAINTENANCE AND RELIABILITY SUSTAINMENT

Innovative or intelligent maintenance systems utilize plant engineering informatics to monitor the health condition of the

system, diagnose the failing components or system and predict the remaining useful life of the system using failure trajectories of the system. The implementation of these systems requires a combination of human factors, maintenance procedure/process and plant (Plant information) in a creative manner. The proposed intelligent maintenance model incorporate innovative maintenance solution right from the requirement, specification and design phases to the operations/maintenance phase of the SDLC as indicated in Figure 3.

### A. Condition-based Predictive Maintenance: An Intelligent Maintenance Solution

Condition-based Predictive maintenance (CBPM) approach is an intelligent maintenance (IM) philosophy or intelligent prognostics system, that monitors the production system's conditions and performances using sensor signals, detect fault at the incipient stage, estimate and predict the future state of the system. In addition to deployment of advanced engineering tools and techniques to modelling and development of intelligent maintenance solution, it also advocates incorporation of the maintenance system in the product life cycle. Thus CBPM is a holistic approach to enterprise asset lifecycle optimization and management. The proposed CBPM model balances interfaces between human factors, maintenance processes and production system to develop optimal and effective R&M solution during O&M phase of SDLC. In [20], it is stated that the concept of life cycle maintenance was introduced to stress the importance of maintaining the products in an acceptable functional level during their lifecycle while continuously improving them as well as maintenance techniques so that existing products can adapt to changes in the operational and technological environment.

### B. Related Works on Intelligent Maintenance System

A lot of research and development works had been carried out over the years on intelligent maintenance strategies, and it is still ongoing due to numerous improvement opportunities yet to be explored. A review of past research works on intelligent maintenance system shows that it has been on since year 1998 and in progress with various names such as intelligent maintenance system [34], intelligent prognostic system [35], e-maintenance [36], condition monitoring system [37], condition-based predictive maintenance system [7], etc. These maintenance systems are mostly developed for specific assignments; they are not scalable, portable or applicable to other systems [35]. For instance, commendable successes have been recorded in intelligent maintenance system for commercial and military aircrafts, marine vessels and industrial machinery health condition monitoring and prognostics using advanced engineering principles such as multi-sensor data fusion (MSDF) technology.

### C. Multisensory Data Fusion for Intelligent Maintenance system

Applications of multisensory data fusion (MSDF) technology span a wide range from robotics, automated manufacturing, remote sensing and condition-based maintenance of industrial



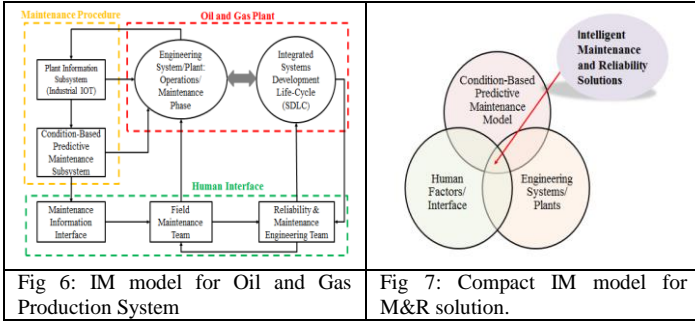

especially at the incipient stage of a slow developing or evolving fault. The introduction of artificial neural network (ANN) that mimics the ability of a biological neuron in human brains to learn and adapt to the changing environment and provides an intelligent solution, especially when there is no exact physic-based mathematical models of the GT system are available [38-42]. This paper focuses on the supervised multilayer perceptron (MLP) feed-forward neural network (FFNN) with back propagation learning algorithm.

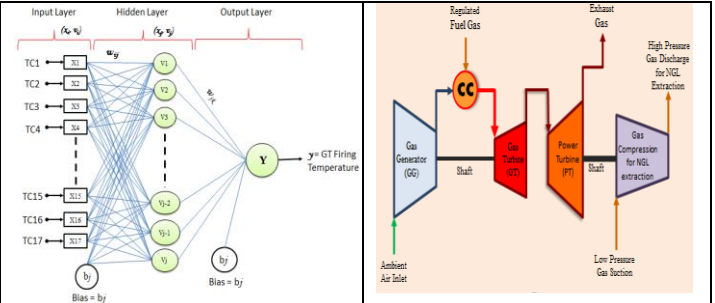

systems to military applications such as battlefield surveillance, tactical situation assessment and threat assessment. For a drivetrain and high capacity industrial gas compressor applications, for example, sensor data can be obtained from accelerometers, temperature sensors, pressure sensors, flow sensors, and vibration sensors. An online condition-monitoring system combines these observations in order to identify signs of failure, such as abnormal gear wear, shaft misalignment, bearing failure and low performance of the system. The use of such condition-based monitoring is expected to reduce maintenance costs, reduce operational risk and improve safety, improve productivity and reliability [37]. MSDF techniques can be categorized into probabilistic and statistical methods, Least-square and mean square methods and heuristic Methods. The heuristic methods include artificial neural network (ANN), fuzzy logic and approximate reasoning In this paper, ANN technique of MSDF is considered.

Fig 8: simplified model of a feedforward neural network (FFNN) Fig 9: Abstraction of gas processing system

#### D. Basic Estimation Fusion Process

Consider a system with  $n$  number of sensors, at the sensor node, the following parameters are specified:  $\mathbf{Z}_i$  is the observations with,  $\mathbf{R}_i$  the covariance matrix of the associated noises

$x$  is the variable to be estimated, and  $\hat{x}$  is the local estimate of  $x$ , with its covariance matrix  $\mathbf{P}_i = \text{cov}(\hat{x})$

Thus the estimation error  $\tilde{x} = \hat{x} - x$

For unified fusion model:

$$\mathbf{z}_i = \mathbf{h}_i \mathbf{x} + \boldsymbol{\eta}_i \quad (2)$$

Where:  $\mathbf{z}_i$  is the measurement of the  $i^{\text{th}}$  sensor and  $\boldsymbol{\eta}_i$  is the measurement noise

A local estimate is considered as an observation of the estimate and is given by:

$$\hat{x} = x + (\hat{x} - x) \quad (3)$$

If the new observation  $\hat{x}$  is actually the estimate of  $x$ , the standard distributed fusion model is given as:

$$\hat{x} = x + (-x) \quad (4)$$

### V. ARTIFICIAL NEURAL NETWORK TECHNIQUE OF MSDF FOR PREDICTION OF GT PERFORMANCE

The presence of multiple faults in a system such as gas turbine (GT) system can make fault identification very complex,

In the FFNN model presented above, each neuron in a given layer is connected with all neurons in the next layer. The connection between  $i^{\text{th}}$  and  $j^{\text{th}}$  neurons is given by coefficient  $w_{ij}$  and the threshold coefficient or bias  $b_j$ . And the output of the  $i^{\text{th}}$  neuron  $x_i$  is given by the equations:

$$O_i = b_j + \sum_{j=1}^n w_{ij} x_j \quad (5)$$

Where  $b_j$  is bias,  $O_i$  is the potential or output of the  $i^{\text{th}}$  neuron and function  $f(O_i)$  is the transfer function, given by:

$$f(O_i) = \frac{1}{1 + e^{-O_i}} \quad (6)$$

In a supervised learning, the bias  $b_j$  and weight coefficient  $w_{ij}$  are varied till the cost function or error  $J$ , is minimized or equaled to zero. That is, the sum of the squared differences between the predicted output and the actual output is the mean squared error or the cost function, and it is given by:

$$J = \frac{1}{N} \sum_{i=1}^N (O_i - f(O_i))^2 \quad (7)$$

A comprehensive details of the mathematical analysis of multi-layer perceptron feed forward neural network is found in [41]. The diagram in Figure 8 shows a simplified model of a feedforward neural network (FFNN) with seventeen temperature sensors data to input layer, the hidden layer,  $v$  with bias =  $b_j$  and the output layer,  $Y$ , with bias =  $b_j$ . The output  $y_k$  is the firing temperature of the GT that drives power turbine.

#### A. Condition-Based Predictive Maintenance of Gas Processing system

##### Overview of oil and gas processing systems

Oil and gas operations involve flowing or pumping of crude oil with entrained gas from oil reservoirs beneath the earth under very high pressure, (in most cases), to the wellheads and transporting the crude oil from wellhead to the production facility. The production operations remove the entrained gas

(the associated petroleum gas (APG)) from the crude oil (mixed with water in some cases), which is further treated to remove basic sediment and water from the oil. The clean oil is then transported to refineries for further processes while the APG is processed for Natural Gas Liquid/Liquefied Natural Gas (NGL/LNG) extraction. This research paper is focusing on gas processing system which involves compression, heating, cooling and separation of various hydrocarbon components. The system is made up of trains of high capacity gas compressors, driven by gas turbine (GT) engines. The GTs are the pivot of these operations because they drive the gas compressors and their exhaust gas is used as heating medium for NGL or LNG extraction processes.

A single train of gas compression system comprises of gas generator (GG), combustion chamber (CC), GT, power turbine (PT) and gas compressor (mostly rotary or centrifugal compressor). See Figure 9.

### B. Analysis of the Results

In this paper, performance of the GT is considered. Seventeen thermocouple temperature sensors are used to monitor firing temperature of the GT, one of the critical parameters of system which affects many system variables and is affected by other variables as well. For example, as the load of the driven system increases, the fuel flow increases, leading to increase in firing temperature of the gas turbine [43]. The speed of the compressor, gas turbine, power turbine and the firing temperature depend on the fuel flow and quality of fuel (constituents of fuel, wet/dirty fuel) and compressor discharge pressure of the GG. Sensor data from this system was collected periodically over a period of thirty days. The data was preprocessed and normalized using z-score and min-max normalization techniques. In this research paper, FFNN with back propagation model is used to predict the firing temperature of the GT engine, with seventeen sensor data set as inputs to the model and the target output. The results of this analysis are shown in Figure 10 indicates that ANN regression model can be used to predict performance of GT engine using exhaust gas temperature sensors. The mean squared error (MSE) of the prediction is as low as 0.00884.

## VI. CONCLUSION

This paper has provided an overview of evolution of maintenance philosophies in oil and gas industries and different maintenance techniques in various phases of this progression have also been discussed extensively. These evolutionary trends are being enforced by progressive and inevitable advances and innovations in technologies and competition in energy sector. It has also been pointed out that among the few reasons the sector is experiencing persistent maintenance challenges are: 1) inability of the industries to integrate innovation in line with applicable, advanced technologies into the maintenance strategies, 2) inability of the industries to analyze the entire system with regards to complexity and emergent behaviours due to high level of interactions among the subsystems. And also, traditional and modern maintenance techniques practiced in oil and gas industries have not

integrated maintenance programs effectively into the total lifecycle of the production system.

These gaps, other maintenance and reliability challenges in oil and gas sectors, identified by this paper are being considered in this research. Most of the modern maintenance practices have made commendable efforts to close some of these gaps with obvious levels of contradictions and compromise. The innovative maintenance system is aiming at closing these gaps, by proposing a model of intelligent maintenance and reliability solutions, which considers human factors from concept phase to the final phase of SDLC. FFNN technique of MSDF for estimation and prediction of GT engine firing temperature is also presented. FFNN is very effective in fusing multiple sensor data with prediction mean square error (MSE) as low as 0.00884.

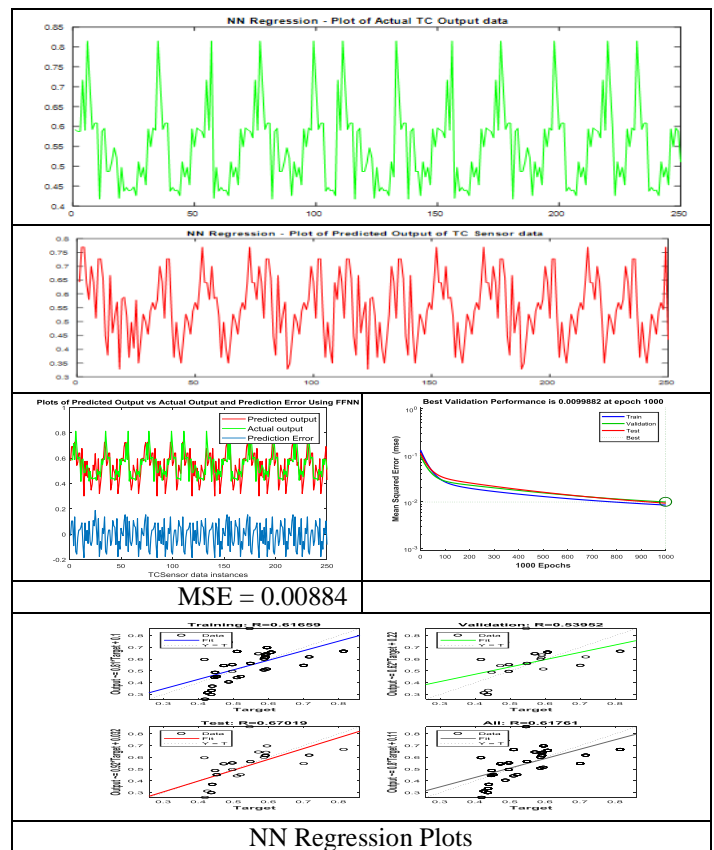

Fig 10: Result of MSDF of GT Firing temperature sensors data using FFNN

## REFERENCES

1. Pate-cornell, M. E. (1993). Learning from the Piper Alpha Accident : A Postmortem Analysis of Technical and Organizational Factors. Risk Analysis, Vol. 13, No. 2, 1993, 13(2). <http://engineeringfailures.org/files/Learning%20from%20the%20Piper%20Alpha%20Accident.pdf>. (Last accessed 26 September, 2016)
2. Shannon Klabnik (2012) Asset Life Cycle Management Optimizes Performance. The American Oil and Gas Reporters. November 2012 Exclusive Story. <http://www.aogr.com/web-exclusives/exclusive-story/asset-life-cycle-management-optimizes-performance>.
3. Garga, A. K., & Byington, C. S. (2008). Data Fusion for Developing Predictive Diagnostics for Electromechanical Systems. *Handbook of Multisensor Data Fusion*, 0, 701–737. <http://doi.org/10.1201/9781420053098.ch28>.

4. R. C. Mishra, K. Pathak, Maintenance Engineering and Management, Second Edition. ISBN – 978-81-203-4573-7.
5. Dhillon, B. S. Engineering Maintenance: A Modern Approach. P.cm ISBN 1-58716-142-7
6. Gomes, C. F., & Yasin, M. M. (n.d.). A Literature Review of Maintenance Performance Measurement: Directions for Future Research, 1–15.  
<http://www.emeraldinsight.com/journals.htm?articleid=1926752&show=abstract> (Last accessed 21 September, 2016)
7. Bernard Schmidt, Ulf Sandberg, L. W. (2004). Next Generation Condition Based Predictive Maintenance. *Methods*, 13306, 4–11.  
<http://www.diva-portal.org/smash/get/diva2:748786/FULLTEXT01.pdf>
8. Barry Eichengreen (2011), Global Shifts, University of California, Berkeley. Prepared for the Bank of Finland's 200th anniversary symposium, Helsinki, May 5-6, 2011.
9. Kobayashi, K. A. H; Murthy, D. N. P. (Eds). Complex System Maintenance Handbook, 2008, XII, 660 p. Hardcover. ISBN: 789-1-84800-010-0 <http://www.springer.com/978-1-84800-010-0>
10. Imad Alsayouf. (2007). The role of maintenance in improving companies' productivity and profitability. *International Journal of Production Economics*, 105, 70–78.  
<http://doi.org/10.1016/j.ijpe.2004.06.057>.
11. Swanson, L. (2001). Linking maintenance strategies to performance. *International Journal of Production Economics*, 70.  
[http://dx.doi.org/10.1016/S0925-5273\(00\)00067-0](http://dx.doi.org/10.1016/S0925-5273(00)00067-0)
12. Mobley, R. K., & Wikoff, D. J. (n.d.). *MAINTENANCE ENGINEERING HANDBOOK*.
13. Gupta, S., & Sharma, S. C. (2005). Selection and application of advanced control systems: PLC, DCS and PC-based system. *Journal of Scientific & Industrial Research* Vol. 64, April 2005, pp. 249–255, 64(April), 249–255.  
[http://nopr.niscair.res.in/bitstream/123456789/5095/1/JSIR%2064\(4\)%20249-255.pdf](http://nopr.niscair.res.in/bitstream/123456789/5095/1/JSIR%2064(4)%20249-255.pdf) (Last accessed 26 September, 2016)
14. J. B. Wintle, B. W.enzie, G. J. Amphlett, S. S. (2001). Best practice for risk based inspection as a part of plant integrity management, Contract Research Report 363/2001.  
[www.hse.gov.uk/research/crr\\_pdf/2001/crr01363.pdf](http://www.hse.gov.uk/research/crr_pdf/2001/crr01363.pdf). (Last accessed 28 September, 2016)
15. John Woodhouse. (n.d.). RISK-BASED MAINTENANCE & INSPECTION DECISIONS John Woodhouse, Project Manager Eureka MACRO programme Managing Director, the Woodhouse Partnership Ltd. August, 2012. [www.twpl.com/wp-content/.../Risk-based-Decisions-paper\\_edited-August-2012.pdf](http://www.twpl.com/wp-content/.../Risk-based-Decisions-paper_edited-August-2012.pdf)
16. Venkatesh, J. (2007). An Introduction to Total Productive Maintenance (TPM) What is Total Productive Maintenance (TPM)? Types of maintenance: 1–22. [http://www.plant-maintenance.com/articles/tpm\\_intro.shtml](http://www.plant-maintenance.com/articles/tpm_intro.shtml)
17. Steven, B. (n.d.). Total Productive Maintenance: Proven strategies and techniques to keep Equipment running at peak efficiency. DOI: 10.1036/0071467335
18. Lee, J., Ni, J., Djurdjanovic, D., Qiu, H., & Liao, H. (2006). Intelligent prognostics tools and e-maintenance. *Computers in Industry*, 57(6), 476–489.  
<http://doi.org/10.1016/j.compind.2006.02.014> (Last accessed 2 October, 2016)
19. IAEA - International Atomic Energy Agency. (2007). TECDOC 1551: Implementation Strategies and Tools for Condition Based Maintenance at Nuclear Power Plants, (May) 2007, 1–178. ISBN 92–0–103907–7. [http://www-pub.iaea.org/MTCD/publications/PDF/te\\_1551\\_web.pdf](http://www-pub.iaea.org/MTCD/publications/PDF/te_1551_web.pdf).
20. Takata, S., Kimura, F., Van Houten, F. J. A. M., Westkaemper, E., Shpitalni, M., Ceglarek, D., And Lee, J. (2004). "Maintenance: Changing Role in Life Cycle Management." *Annals of CIRP*, 53(2), 634–655.  
<http://www.sciencedirect.com/science/article/pii/S000785060760033X> (Last accessed 26 September, 2016)
21. Carliss Y. Baldwin, Kim B. Clark. Modularity in the Design of Complex Engineering Systems, January 2004.  
[www.people.hbs.edu/cbaldwin/dr2/baldwinclarkces.pdf](http://www.people.hbs.edu/cbaldwin/dr2/baldwinclarkces.pdf)
22. Pierre Mons, Laurent Tapie, Luc Mathieu, Benoit Dantin, Nicolas Chevasus. Modular Design for Complex Systems. Proceedings of IDMME - Virtual Concept 2010.
23. Tyson R. Browning (August 2001). Applying the Design Structure Matrix to System Decomposition and Integration Problems: A Review and New Directions. *IEEE Transactions on Engineering Management*, VOL. 48, NO. 3, August 2001.
24. Nam P. Suh. Axiomatic Design Theory for Systems. *Research in Engineering Design*. December 1998, Volume 10, Issue 4, pp 189–209.
25. Guenov M. D, Barker S. G. Application of axiomatic design and design structure matrix to the decomposition of engineering systems. *Systems Engineering*. Vol.8 No.1, 2005.
26. Mike Danilovic, Bengt Sandkull, The use of dependence structure matrix and domain mapping matrix in managing uncertainty in multiple project situations. *International Journal of Project Management* 23 (2005) 193–203.
27. Hsieh, Y-C., (2002), "A Two-Phase Linear Programming Approach for Redundancy Allocation Problems", *Yugoslav Journal of Operations Research*, Vol. 12, No. 2, pp. 227- 236. 81
28. Ramirez-Marquez, J.E. and Coit, D.W., (2004), "A Heuristic for Solving the Redundancy Allocation Problem for Multi-State Series-Parallel Systems", *Reliability Engineering and System Safety*, Vol. 83, pp. 341-349
29. Liang, Y-C. And Chen, Y-C, (2007), "Redundancy Allocation of Series-Parallel Systems Using a Variable Neighborhood Search Algorithm", *Reliability Engineering and System Safety*. Vol. 92, pp. 323–331.
30. Yun, W-Y, and Kim, J-W., (2004), "Multi-Level Redundancy Optimization in Series Systems", *Computers & Industrial Engineering*, Vol. 46, pp. 337-346. 85.
31. Khalili-Damghani K, Amiri M (2012) Solving binary-state multi-objective reliability redundancy allocation series-parallel problem using efficient epsilon-constraint, multi-start partial bound enumeration algorithm, and DEA. *Reliab Eng Syst Saf* 103:35–44.
32. Mostafa Abouei Ardakan, Ali Zeinal Hamadani (2014) Reliability optimization of series-parallel systems with mixed redundancy strategy in subsystems. *Reliability Engineering and System Safety* 130 (2014) 132–139.
33. Srinivasa Rao M, Naikan VNA (2014) Reliability analysis of repairable systems using system dynamics modeling and simulation. *J Ind Eng Int* 10:1–10. doi:10.1007/s40092-014-0069-3
34. IMS. (2007). "Center for Intelligent Maintenance System." <http://www.imscenter.net/>. (Last accessed 2 October, 2016)
35. Lee, J., Ni, J., Djurdjanovic, D., Qiu, H., & Liao, H. (2006). Intelligent prognostics tools and e-maintenance. *Computers in Industry*, 57(6), 476–489.  
<http://doi.org/10.1016/j.compind.2006.02.014>
36. Levrat, E., & Iung, B. (2006). TELMA: A full e-maintenance platform. Centre de Recherche en Automatique de Nancy (CRAN) - UMR 7039. Retrieved from <http://www.incose.org>.
37. Starr, A., Willetts, R., Hannah, P., Hu, W., Banjevic, D., & Jardine, A. K. S. (n.d.). Data fusion applications in intelligent condition monitoring. [www.wseas.us/e-library/conferences/crete2002/papers/444-802.pdf](http://www.wseas.us/e-library/conferences/crete2002/papers/444-802.pdf).
38. Hall, David L; Llinas, J. (n.d.). *Handbook of Multisensor Data Fusion: The Electrical Engineering and applied signal Processing Series*.
39. D. Baillie and J. Mathew, "A comparison of autoregressive modeling techniques for fault diagnosis of rolling element bearings", *Mechanical Systems and Signal Processing*, Vol. 10, pp. 1-17, 1996.
40. B. Paya, M. Badi and I. Esat, "Artificial neural network based fault diagnostics of rotating machinery using wavelet transforms as a preprocessor", *Mechanical Systems and Signal Processing*, Vol. 11 (5), pp. 751-765, 1997.



41. Guoqiang Peter Zhang. Neural networks for classification: a survey. *Systems, Man, and Cybernetics, Part C: Applications and Reviews*, IEEE Transactions on, 30(4):451-462, 2000.
42. *Chemometrics and Intelligent Laboratory Systems* 39 (1997) 43-62
43. Rainer Kurz. Gas Turbine Performance. *Proceedings of the Thirty-Fourth Turbomachinery Symposium – 2005*