

This item was submitted to Loughborough's Institutional Repository (<https://dspace.lboro.ac.uk/>) by the author and is made available under the following Creative Commons Licence conditions.



For the full text of this licence, please go to:
<http://creativecommons.org/licenses/by-nc-nd/2.5/>

**QUANTIFICATION OF HUMAN OPERATOR
SKILL IN A DRIVING SIMULATOR FOR
APPLICATIONS IN HUMAN ADAPTIVE
MECHATRONICS**

By

Mohamad Hafis Izran Bin Ishak

A Doctoral Thesis submitted in partial fulfilment of the requirement
for the award of
Doctor of Philosophy of Loughborough University

July 2011

© by Mohamad Hafis Izran B Ishak 2011

ABSTRACT

Nowadays, the Human Machine System (HMS) is considered to be a proven technology, and now plays an important role in various human activities. However, this system requires that only a human has an in-depth understanding of the machine operation, and is thus a one-way relationship. Therefore, researchers have recently developed Human Adaptive Mechatronics (HAM) to overcome this problem and balance the roles of the human and machine in any HMS. HAM is different compared to ordinary HMS in terms of its ability to adapt to changes in its surroundings and the changing skill level of humans. Nonetheless, the main problem with HAM is in quantifying the human skill level in machine manipulation as part of human recognition. Therefore, this thesis deals with a proposed formula to quantify and classify the skill of the human operator in driving a car as an example application between humans and machines. The formula is evaluated using the logical conditions and the definition of skill in HAM in terms of time and error. The skill indices are classified into five levels: Very Highly Skilled, Highly Skilled, Medium Skilled, Low Skilled and Very Low Skilled.

Driving was selected because it is considered to be a complex mechanical task that involves skill, a human and a machine. However, as the safety of the human subjects when performing the required tasks in various situations must be considered, a driving simulator was used. The simulator was designed using Microsoft Visual Studio, controlled using a USB steering wheel and pedals, as was able to record the human

path and include the desired effects on the road. Thus, two experiments involving the driving simulator were performed; 20 human subjects with a varying numbers of years' experience in driving and gaming were used in the experiments. In the first experiment, the subjects were asked to drive in Expected and Guided Conditions (EGC). Five guided tracks were used to show the variety of driving skill: straight, circular, elliptical, square and triangular. The results of this experiment indicate that the tracking error is inversely proportional to the elapsed time. In second experiment, the subjects experienced Sudden Transitory Conditions (STC). Two types of unexpected situations in driving were used: tyre puncture and slippery surface. This experiment demonstrated that the tracking error is not directly proportional to the elapsed time. Both experiments also included the correlation between experience and skill. For the first time, a new skill index formula is proposed based on the logical conditions and the definition of skill in HAM.

Keywords: Human Machine System, Human Adaptive Mechatronics, skill, driving simulator, skill index, human subject, experience, expected and guided conditions, sudden transitory conditions.

ACKNOWLEDGEMENTS

Praise to Allah, the Most Gracious and Most Merciful, for giving me courage and guidance to write this thesis.

First of all, I would like to express my deepest gratitude to Prof. Rob Parkin and Prof. Mike Jackson for their tremendous support, supervision and encouragement throughout this work. Your insightful suggestions during the numerous discussions that we had were invaluable for this research. I am also indebted to Prof. Rob Parkin for his helpful comments on the final version of the thesis.

Special thanks to my sponsors, Malaysia Ministry of Higher Education and Universiti Teknologi Malaysia, for financial support during my stay in the UK.

My family, especially my mum, my wife, my kids, my sisters and my brother, have been the main inspiration and source of everlasting support and comfort throughout my research studies and I really cannot thank them enough for everything. Thank you so much for always be with me in whatever situations.

I am also thankful to all colleagues at Mechatronics Research Group especially Mathavan, Tussanai, Najib, Nashtara, Sultan, Vianney, Khurram, Sedat, Matthew, Phil and Luke, for their constructive comments, suggestions and involvement in my experiments. Also, thanks to Ms Jo Mason for helping me out with paperwork.

I am also grateful to all Malaysian students and their family at Loughborough University for taking part in my experiments. I also would like to acknowledge my best friend, Usman for giving me the best support from Malaysia.

Last but not least, special thanks to all individuals who have directly or indirectly offered help, suggestion and support in bringing towards the completion of this thesis. Thank you so much.

Dedicated ;

To my mum,

Wan Zainey Wan Ahmad

To my wife,

Nurul Hawani Idris,

To my little kids,

Melati Aisyah & Muhammad Khalil Imran

And all families.

TABLE OF CONTENTS

ABSTRACT	i
ACKNOWLEDGEMENTS	iii
DEDICATION	iv
TABLE OF CONTENTS	v
LIST OF ABBREVIATIONS	xii
LIST OF SYMBOLS	xiii
LIST OF FIGURES	xiv
LIST OF TABLES	xvi
CHAPTER 1	
INTRODUCTION	1
1.1 HUMAN AND MACHINE.....	1
1.2 PROBLEM STATEMENT	3
1.3 AIM AND OBJECTIVES	6
1.4 SCOPE OF WORK	7
1.5 CONTRIBUTIONS.....	8
1.5.1 PROPOSE NEW SKILL INDEX TECHNIQUE	8
1.5.2 EVALUATE SKILL IN VARYING CONDITIONS	8
1.5.3 MEASURE HUMAN TRACKING ERROR	8
1.5.4 RELATE HUMAN SKILL AND EXPERIENCE	9
1.6 THESIS OUTLINE	9

CHAPTER 2

LITERATURE REVIEW.....	11
2.1 INTRODUCTION.....	11
2.2 HUMAN MACHINE SYSTEM (HMS).....	12
2.3 HUMAN ADAPTIVE MECHATRONICS (HAM).....	15
2.3.1 DEFINITIONS.....	15
2.3.2 ELEMENTS IN HAM.....	18
2.3.3 SKILL IN HAM.....	19
2.4 DRIVING, SKILL, PERFORMANCE AND EXPERIENCE.....	21
2.5 HUMAN MODEL.....	23
2.5.1 QUASI-LINEAR MODEL.....	23
2.5.2 OPTIMAL CONTROL MODEL.....	24
2.5.3 LINEAR PARAMETRIC MODEL.....	25
2.5.4 INTELLIGENT MODEL.....	27
2.6 COMPARISONS AMONG SELECTED HUMAN MODELS.....	28
2.7 RESEARCHES RELATED HAM.....	29
2.7.1 TELE-OPERATION SYSTEM IN HAM.....	29
2.7.2 HUMAN CALIBRATION FOR HAM.....	32
2.7.3 PURSUIT TRACKING FOR HAM.....	35
2.8 SUMMARY.....	37

CHAPTER 3

METHODOLOGY.....	41
3.1 INTRODUCTION.....	41
3.2 RESEARCH METHODOLOGY.....	42

3.3 CHOICE OF SOFTWARE USED.....	44
3.4 GRAPHICAL USER INTERFACE (GUI) DESIGN.....	44
3.4.1 MAPMAKER.....	45
3.4.2 CAR DRIVING SIMULATOR.....	49
3.4.3 ERROR COMPUTATION PROGRAM.....	53
3.5 ERROR MEASUREMENT METHOD.....	55
3.6 EXPERIMENTAL WORK.....	59
3.6.1 DRIVING DURING EXPECTED AND GUIDED CONDITIONS.....	59
3.6.2 DRIVING DURING SUDDEN TRANSITORY CONDITIONS.....	59
3.7 EXPERIMENTAL SETUP'.....	60
3.8 HARDWARE USED.....	61
3.8.1 MONITOR.....	62
3.8.2 PC DESKTOP.....	62
3.8.3 STEERING WHEEL AND PEDALS.....	63
3.9 TRACK CREATED.....	65
3.9.1 STRAIGHT.....	65
3.9.2 CIRCULAR.....	66
3.9.3 ELLIPTICAL.....	67
3.9.4 SQUARE.....	68
3.9.5 TRIANGULAR.....	69
3.10 HUMAN SUBJECTS' FEATURES.....	70
3.11 SUMMARY.....	71

CHAPTER 4

PROPOSED SKILL INDEX FORMULA.....	72
4.1 INTRODUCTION	72
4.2 NORMALIZATION - IN GENERAL.....	73
4.3 NORMALIZED TIME.....	73
4.3.1 THE BEST TIME, T_B	74
4.4 NORMALIZED ERROR.....	75
4.4.1 THE SMALLEST POSSIBLE ERROR, E_S	76
4.5 FORMULA DEVELOPMENT.....	77
4.5.1 VALUE C.....	79
4.5.2 VALUE A.....	80
4.5.3 VALUE B.....	80
4.5.4 FINAL FORMULA.....	81
4.6 CLASSIFICATION OF SKILL.....	81
4.7 ALTERNATIVE FORMULAS.....	82
4.7.1 FUZZY LOGIC.....	82
4.7.2 SASAKI'S FORMULA.....	85
4.8 SUMMARY.....	87

CHAPTER 5

STUDY OF HUMAN SKILL IN EXPECTED AND GUIDED CONDITIONS

(EGC).....	88
5.1 INTRODUCTION.....	88
5.2 OBJECTIVES OF EXPERIMENT.....	89
5.3 SCOPE OF EXPERIMENT.....	90

5.4 HYPOTHESES.....	92
5.5 EXPERIMENT FEATURES.....	93
5.6 EXPERIMENTAL PROCEDURE.....	94
5.7 RESULTS BY TRACK.....	96
5.7.1 STRAIGHT TRACK.....	96
5.7.2 CIRCULAR TRACK.....	101
5.7.3 ELLIPTICAL TRACK.....	105
5.7.4 SQUARE TRACK.....	110
5.7.5 TRIANGULAR TRACK.....	114
5.8 ANALYSIS.....	119
5.8.1 SMALLEST POSSIBLE ERROR, E_s	119
5.8.2 AVERAGE ERROR.....	119
5.8.3 SKILL INDEX.....	120
5.8.4 AVERAGE SKILL INDEX.....	126
5.8.5 OVERALL SKILL INDEX AND EXPERIENCE	127
5.8.6 EFFECTS OF EXPERIENCE AND AGES.....	129
5.9 SUMMARY.....	130

CHAPTER 6

STUDY OF HUMAN SKILL IN SUDDEN TRANSITORY CONDITIONS

(STC).....	131
6.1 INTRODUCTION.....	131
6.2 OBJECTIVES OF EXPERIMENT.....	132
6.3 SCOPE OF EXPERIMENT.....	133
6.4 HYPOTHESES.....	134

6.5 EXPERIMENT FEATURES.....	135
6.6 PROCEDURES.....	136
6.7 RESULTS.....	138
6.7.1 STC1: STRAIGHT TRACK WITH FIXED PUNCTURE.....	138
6.7.2 STC2: STRAIGHT TRACK WITH RANDOM SLIPPERY SURFACE.....	143
6.7.3 STC3: ELLIPTICAL TRACK WITH FIXED PUNCTURE.....	147
6.7.4 STC4: SQUARE TRACK WITH RANDOM SLIPPERY SURFACE.....	152
6.8 ANALYSIS.....	157
6.8.1 ERROR ANALYSIS.....	157
6.8.2 SKILL INDEX.....	158
6.8.3 AVERAGE SKILL INDEX.....	163
6.8.4 OVERALL SKILL INDEX FOR EACH SUBJECT.....	164
6.8.5 EFFECTS OF EXPERIENCE AND AGES.....	167
6.9 SUMMARY.....	169

CHAPTER 7

DISCUSSION.....	170
7.1 INTRODUCTION.....	170
7.2 SKILL INDEX FORMULA.....	171
7.2.1 THE PROPOSED FORMULA.....	171
7.2.2 FORMULA VALIDATION AND COMPARISON.....	172
7.2.3 ADVANTAGES.....	174
7.2.4 LIMITATION.....	175
7.3 THE EXPERIMENTS AND RELATED ISSUES.....	175
7.4 RESULTS AND RELATED ISSUES.....	177

7.5 RELIABILITY OF THE RESULTS.....	181
7.6 CORRELATION AND STATISTICAL ERRORS.....	183
7.7 SUMMARY.....	185
CHAPTER 8	
CONCLUSIONS AND FURTHER WORK.....	186
8.1 CONCLUSIONS.....	186
8.1.1 HUMAN SKILL INDEX.....	187
8.1.2 SKILL IN VARYING CONDITIONS.....	187
8.1.3 HUMAN ERROR BASED ON MINIMUM DISTANCE.....	188
8.1.4 HUMAN SKILL AND EXPERIENCE.....	188
8.2 RECOMMENDATIONS FOR FURTHER WORK.....	189
REFERENCES.....	191
APPENDIX 1:	
RESULTS FOR EGC.....	204
APPENDIX 2:	
NORMALIZED DATA FOR EGC.....	209
APPENDIX 3:	
RESULTS FOR STC.....	214
APPENDIX 4:	
NORMALIZED DATA FOR STC.....	218
APPENDIX 5:	
PROGRAMMING SOURCE CODE.....	222

LIST OF ABBREVIATIONS

2D	Two dimensions
3D	Three dimensions
ANFIS	Adaptive-network-based Fuzzy Inference System
D	Minimum Distance
DE	Driving Experience
ED	Euclidean Distance
EGC	Expected and Guided Conditions
F	Fast
FLS	Fuzzy Logic System
GE	Gaming Experience
GUI	Graphical User Interface
HAM	Human Adaptive Mechatronics
HMM	Hidden Markov Model
HMS	Human Machine System
HS	Highly Skilled
L	Large
LS	Low Skilled
M	Medium
MS	Medium Skilled
NN	Neural Network
P	Path
PC	Personal Computer
PRBS	Pseudo Random Binary Signal
S	Small
SI	Slow
STC	Sudden Transitory Conditions
T	Track
VHS	Very Highly Skilled
VLS	Very Low Skilled

LIST OF SYMBOLS

α	Cronbach's alpha (reliability test)
e	tracking error (dimensionless)
E_n	Normalized error
E_s	The smallest possible error
J	Skill index
L	Length of track (units)
t	elapsed time (seconds)
T_B	The best theoretical time (seconds)
T_n	Normalized time
V_{max}	maximum speed in driving simulator (600 unit/sec)
X_P	coordinate x for path
X_T	coordinate x for track
Z_P	coordinate z for path
Z_T	coordinate z for track

LIST OF FIGURES

Figure No.	Title	Page
1.1	Percentage of accidents with contributory factor type in Great Britain (2009). Source data from National Statistic: Department for Transport (2009).	5
2.1	An example block diagram of HMS (Hidaka <i>et al.</i> , 2006)	14
2.2	Schematic diagram of Human Adaptive Mechatronics (Furuta, 2004)	17
2.3	An example of Human Adaptive Mechatronics System. Adapted from Suzuki <i>et al.</i> , 2006b.	17
2.4	The quasi-linear human model (McRuer and Krendel, 1959)	24
2.5	Optimal human model (Kleinman <i>et al.</i> , 1970)	24
2.6	Example of human control model using ARX (Suzuki <i>et al.</i> , 2006)	26
2.7	Block diagram of tele-operation system (Hidaka <i>et al.</i> , 2006)	30
2.8	Experimental set-up of Maeda <i>et al.</i> (2007).	31
2.9	Experiment environment of Igarashi (2008)	33
2.10	Errors defined by Igarashi (2008)	33
2.11	The PRBS and its frequency spectrum that was used as the input signal by Ertugrul (2007)	36
3.1	Flowchart of overall methodology	42
3.2	Example of track pattern created in MapMaker.	46
3.3	The point X on x and z axes.	46
3.4	The example of coordinates of X and Z saved in text file.	47
3.5	File menu in the MapMaker.	48
3.6	MapMaker can be used to compare the track and the path.	48
3.7	The designed driving simulator program gives the user a perspective preview of the road ahead and the green line as guidance. The user has independent control of the steering, brake and accelerator.	50
3.8	The schematic diagram of the physical system.	52
3.9	A flow diagram for the control system.	53

3.10	Error computation program	54
3.11	Flowchart of error measurement.	55
3.12	The initial point, a and the created points, b .	57
3.13	Block diagram of the experimental work.	60
3.14	Experimental setup and hardware used.	61
3.15	(a) Logitech MOMO Steering wheel (b) Foot Pedals	63
3.16	Straight track.	65
3.17	Circular track.	66
3.18	Elliptical track.	67
3.19	Square track.	68
3.20	Triangular track.	69
4.1	The way to select a value and range for each skill level.	78
4.2	Inputs and output for Fuzzy Logic System.	83
4.3	Membership functions for normalized error, E_n .	83
4.4	Membership functions for normalized time, T_n .	84
4.5	Membership functions for skill index, J .	84
4.6	Normalized graph, T_n versus E_n .	86
5.1	Flowchart of the experimental procedure.	95
5.2	Results from straight track.	97
5.3	Average results for straight track in each trial.	100
5.4	Results from circular track.	102
5.5	Average results for circular track in each trial.	105
5.6	Results from elliptical track.	106
5.7	Average results for elliptical track in each trial.	109
5.8	Results from square track.	111
5.9	Average results for square track in each trial.	114
5.10	Results from triangular track.	115
5.11	Average results for triangular track in each trial.	118
6.1	Flowchart of the experimental procedure.	137
6.2	Results from STC1.	139
6.3	Average results for STC1 in each trial.	142
6.4	Results from STC2.	144
6.5	Average results for STC2 in each trial.	147
6.6	Results from STC3.	148
6.7	Average results for STC3 in each trial.	151
6.8	Results from STC4.	153
6.9	Average results for STC4 in each trial.	156

LIST OF TABLES

Table No.	Title	Page
1.1	Comparisons between HMS and HAM.	3
2.1	Human model comparison.	28
2.2	Comparisons between Igarashi's experiment and this thesis experiment.	34
2.3	Summary of literature review related to HAM.	38
3.1	PC specifications.	62
3.2	Human subjects' experience in driving and gaming and their age.	70
4.1	The best time of each track in the driving simulator.	75
4.2	Combination of E_n and T_n for each skill index, J .	77
4.3	The equivalent values used for E_n , T_n and J .	79
4.4	Range for each level of J .	82
4.5	Rules for example Fuzzy Logic System.	85
4.6	Skill level based on Sasaki <i>et al.</i> (2007).	87
5.1	Summary of tracks used in EGC.	93
5.2	E_s for each track.	119
5.3	Average error for each track.	120
5.4	Skill index value and class for each subject from straight track.	121
5.5	Skill index value and class for each subject from circular track.	122
5.6	Skill index value and class for each subject from elliptical track.	123
5.7	Skill index value and class for each subject from square track.	124
5.8	Skill index value and class for each subject from triangular track.	125
5.9	Average skill index for each subject on every track.	127
5.10	Hypothesis H7 validation for each subject.	128
5.11	The correlation between the skill index, the experiences and the different ages of the subjects in each track.	129
6.1	The features of each STC experiments.	135
6.2	Average error for each STC.	157
6.3	Skill index for STC1.	159
6.4	Skill index for STC2.	160
6.5	Skill index for STC3.	161
6.6	Skill index for STC4.	162
6.7	Average skill index for each subject in every STC.	163
6.8	Average skill indices for EGC and STC (Puncture & Slippery Surface).	164
6.9	Hypothesis H (K) validation for each subject in STC	166

	(Puncture)	
6.10	Hypothesis H (K) validation for each subject in STC (Slippery).	167
6.11	The correlation between the skill indices of every STC, experiences and ages.	168
7.1	The comparisons using synthetic data	172
7.2	Number of subjects used by other researchers	177
7.3	Average error for each track in EGC.	178
7.4	The α between the tracks and results for EGC.	182
7.5	The α between the tracks and results for STC.	182
7.6	Correlation between time and error, and its significant level for EGC.	183
7.7	Correlation between time and error, and its significant level for STC.	184

CHAPTER 1

INTRODUCTION

1.1 HUMAN AND MACHINE

The human machine system (HMS) is relatively synonymous with human life, where most of the machines need to be operated by humans through manual control. Any machine that involves humans can be categorized as HMS, even though it is an open loop system, such as a washing machine, which only needs a human to press a few buttons to make it work. Nonetheless, this system requires only a human to have in-depth understanding of the machine operation, which is a one-way relationship (Harashima and Suzuki, 2006, Furuta, 2004). In other words, for most current technology, only the human is required to learn and understand the machine and its aspects. The machine only receives a command from a human as part of its operation.

The existence of a new improvement system called Human Adaptive Mechatronics (HAM), gives hope that humans and machines can have a two-way relationship, where the machine is able to understand the human, provide feedback and respond to the human action. HAM has been defined as intelligent mechanical systems that adapt to the human skills in the different situations, assist to improve the human skills and assist the human machine system to achieve the best performance (Suzuki and Harashima, 2005, Kurihara *et al.*, 2006).

The HAM system is not directly focused on replacing the human as the main controller in any HMS and becoming autonomous, but rather to support the human in operating the machine. For example, when driving a vehicle, the current technology requires that only the human has to fully ‘adapt’ to the vehicle from various aspects such as operational control, dynamic, safety and reliability. If a HAM system is implemented on the vehicle, it should be able to understand the human, not only know the process of how the vehicle was handled, but also recognize the human skill and provide necessary assistance when needed.

HMS only has a one-way relationship and totally depends on the human. If the human makes an error, then the machine also does the same thing. This asymmetrical relationship always gives rise to problems and an imbalance in achieving the best performance for both parties. On the other hand, HAM is two-way relationship and depends on the interaction between human and machine. Not only is the human learning the machine’s characteristics, but the machine is also adapting to the human individuality and environment, recognizing the differences and giving feedback on

each of the human’s actions. Table 1.1 shows the comparisons between both systems in general.

Table 1.1: Comparisons between HMS and HAM

Feature	HMS	HAM
Relationship	One-way	Two-way
Human Learning	Yes	Yes
Machine Learning	No	Yes
Machine Assist	No	Yes
Controller	Human	Human and Machine
Human Skill Improved	No	Yes
Machine Adapted to Human	No	Yes
Machine Adapted to Environment	No	Yes

1.2 PROBLEM STATEMENT

According to the annual report on Road Casualties Great Britain (2009) as shown in Figure 1.1, the driver/rider error or reaction was the most frequently reported contributory factor and was involved in 69% of all accidents reported to the police in

Great Britain in 2009. This factor includes loss of control, failing to look properly, poor turning or manoeuvring, failing to signal or giving a misleading signal, sudden braking, swerving and failing to judge the other person's path or speed. It is then followed by injudicious action, contributing to 25% in all accidents. This factor is still related to human action such as disobeying automatic traffic lights, disobeying double white lines, illegal turning or direction of travel, exceeding the speed limit and travelling too fast for the conditions. Behaviour or inexperience also contributed to 23 per cent in all accidents, including careless or aggressive driving, reckless driving or driving in a hurry, being unfamiliar with the model of vehicle and being a learner or an inexperienced driver/rider. All these factors show that the human has weaknesses and is always making errors during machine manoeuvre such as driving a car. Therefore, the human needs 'special' assistance not from other humans, but from the machine itself, which is very close to humans during such operations.

Another contributory factor, which is related to the machine, is vehicle defects. This factor was only present in 2% of total accidents. Examples of this factor are overloaded vehicles, defective lights, brakes, steering or suspension, missing mirrors and tyres which are illegal or under inflated. This percentage shows that the machine's condition is less of a contributory factor to accidents, and that problems are still more about human error. In other words, the car as a machine is almost totally safe to operate providing the human as a controller can handle it without error.

Also from Figure 1.1, road environment factors such as slippery roads, poor or defective road surfaces, defective traffic signals, temporary road layout and traffic calming, were involved in 16% of total accidents. This indicates that the human

cannot handle any sudden changes or conditions that occurred due to the environment. Humans are supposed to understand and be able to adapt to any unexpected environments because they are very well prepared, in terms of learning and training. If the machine can also adapt to environments, any difficulties can be eliminated easily because the machine will give appropriate assistance to the human.

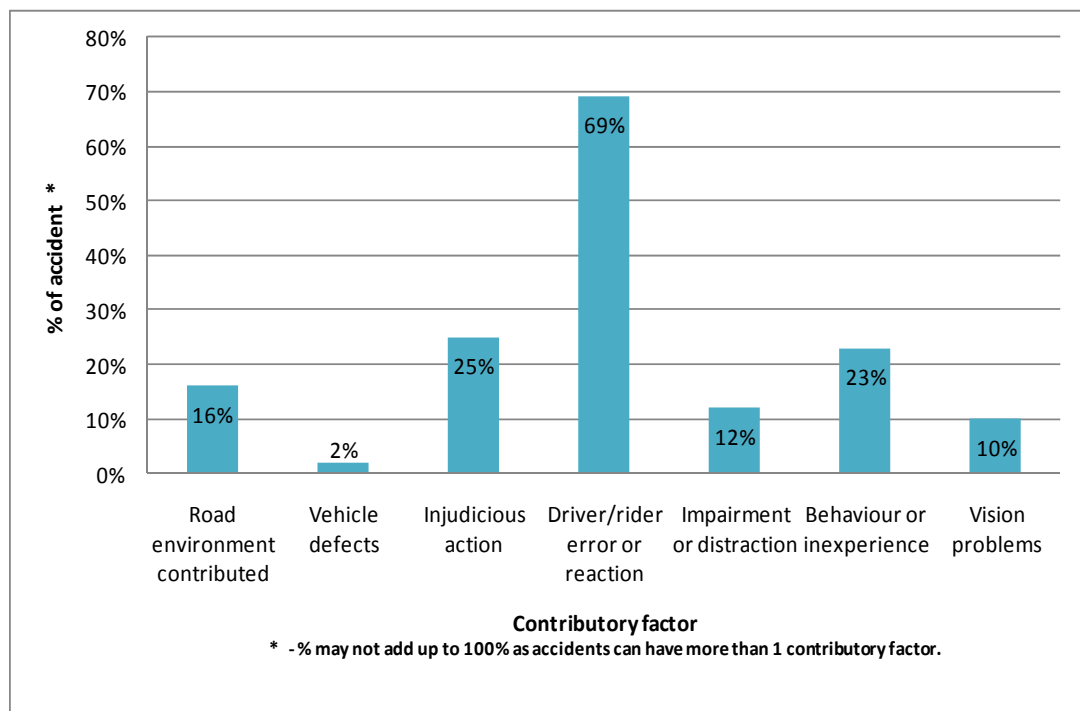

Figure 1.1: Percentage of accidents with contributory factor type in Great Britain (2009). Source data from National Statistic: Department for Transport (2009).

In order to learn and operate the machine, the human needs time and effort. It is difficult to operate the machine without enough knowledge and guidance. For example, the human needs adequate lessons and training to drive a car, but all the burdens are still on human. The machine has no role to play in improving the human skill or performance. In other words, the current machine only exists to simplify the

tasks. Although the machine can assist in certain situations, it still needs the human to determine the perfect time to do so. It is difficult to automatically give assistance when the human really needs it, as the machine still cannot recognize the differences of human features.

1.3 AIM AND OBJECTIVES

The most important element in HAM is the way the machine recognizes the human, as part of its realization. Furthermore, as far as the author is aware, no proper and easier method to quantify and classify the human skill has yet been designed that is specifically targeted to meet the constraints imposed by HAM system. The absence of a method that combines the human error and time acts as the principal motivation for this research. Therefore, the aim of this research is to overcome such major drawbacks of current HAM systems in quantifying and classifying the human skill as part of human recognition.

In order to achieve the aim, the following objectives are apparent:

- a. Through literature studies and practical investigations, highlighting the current issues on HAM and establishing the most promising existing algorithm that can be adapted to deliver a new recognition technique in machine systems.
- b. Designing and implementing the human characteristics evaluation in driving simulator, in order to investigate the human skill.
- c. Developing and implementing a technique to measure the human tracking error based on minimum distance in software simulation.

- d. Classifying the skill index into a few levels of recognition.
- e. Assessing the skill of human subjects with regard to the proposed method when driving in normal conditions.
- f. Demonstrating the proposed quantification approach in unexpected situations.

1.4 SCOPE OF WORK

There are many issues in HAM and the quantification of human skill; however this thesis is restricted to the following scope:

- a. This research only covers the first element of HAM realization, which is the quantification of human skill. Details of all elements are discussed on Chapter 2.
- b. Calculation of skill index is based on normalized error and normalized time, obtained from 20 human subjects from experiments.
- c. The experiments ignore the gender difference among human subjects.
- d. Computer simulation such as the car driving simulator is used to obtain the accomplish time and tracking error from each human subject.
- e. This thesis focuses the human skill in two different simulated conditions, i.e. during normal driving and when there are unexpected situations. In unexpected situations, only two combinations of disturbances are used; these are a tyre punctured with lost control of steering; and slippery surface with the steering tending to turn left.
- f. The computer program is designed to take into account the differences in track shape, control of steering, brake and speed generated from the pedals. Other factors, such as the road surface and car dynamics, are neglected.

- g. The value of normalized time and normalized error are based on ‘special’ conditions discussed in Chapter 4.

1.5 CONTRIBUTIONS

The following is a summary of original contributions made by the author.

1.5.1 PROPOSE NEW SKILL INDEX TECHNIQUE

A new skill index is proposed based on the logical conditions and the definition of skill in HAM. The skill index acts as an indicator and allows the easy recognition of the differences between humans. This contribution is explained in detail in Chapter 4.

1.5.2 EVALUATE SKILL IN VARYING CONDITIONS

As a way to implement and verify the proposed formula, this thesis evaluates human driving skill in various situations, whether in normal conditions or in unexpected conditions. In later chapters, the normal conditions will be known as Expected and Guided Conditions (EGC), and the unexpected situations as Sudden Transitory Conditions (STC). These are done experimentally using a designed driving simulator. This contribution is discussed in detail in Chapter 5 and Chapter 6.

1.5.3 MEASURE HUMAN TRACKING ERROR

A method to calculate the tracking error in the driving simulator is developed and implemented in a simulated program. The method is based on minimum distance

between points. Each point of the track is compared to each point of the path used by the human subject. This contribution is discussed in greater detail in Chapter 3.

1.5.4 RELATE HUMAN SKILL AND EXPERIENCE

Since the experiments mainly involve a computer simulator, this research relates human skill and experience, whether driving or gaming. This research finds a correlation between the value of the human skill level and the number of years of experience. This contribution is included in Chapter 5 and Chapter 6.

1.6 THESIS OUTLINE

The rest of this thesis is organized in the following manner:

Chapter 2 presents an overview of ordinary Human Machine System and detail of Human Adaptive Mechatronics. Related issues concerning driving and humans are also discussed, as well as the selected human models. Finally, the important research that related to HAM and this thesis is presented.

Chapter 3 describes the methodology used in terms of software and hardware setup for experimental works. Methods in data collection are also discussed.

Chapter 4 introduces the proposed skill index formula in HAM. Following the formula development, the normalized method and alternative formula are presented.

Chapter 5 and 6 describe the experimental arrangement used for EGC and STC, respectively. The hypotheses, results and analysis for a series of experiments are also presented.

Chapter 7 discusses the issues and rationales of each component existing from the proposed formula and both experiments such as the skill indices, track patterns, subjects, trials, effects and experience. A comparison is also made between those two driving conditions.

Chapter 8 summarises the thesis described in previous chapters. The conclusions and detail of novelties are presented, as well as suggestions for future research.

CHAPTER 2

LITERATURE REVIEW

2.1 INTRODUCTION

The human machine system (HMS) has been studied since the beginning of the 1940s, but during the 1990s interest in the topic grew considerably. The division of human characteristics or skills into separately studied parts has been a common theme of the field, since a general human model is inherently complex. For example, there exist separate topics for describing human-machine interactions, human in the loop and the human assist system. Thus, this chapter concentrates on a review of the general human machine system, human adaptive mechatronics, human skill and human models.

2.2 HUMAN MACHINE SYSTEM (HMS)

Nowadays, HMS is considered to be a proven technology, which has gained an important place in various human activities. Therefore, there seems to be a general definition of HMS as provided by Chen and Tseng (2007), Itoh and Suzuki (2006), Kulic and Croft (2007), Schiele and van der Hem (2006) and Baron *et al.*(1970). In the broadest sense, the HMS concept encompasses all the interactions between human and mechanistic elements when these elements are united into a system (Soffker, 2001, Schiele and van der Hem, 2006, Rani *et al.*, 2007).

HMS also refers to a closed-loop control system, which comprises a machine and a human controller to complete the system (Kurihara *et al.*, 2006, Phatak *et al.*, 1975, Miller and Elkind, 1967, Levison *et al.*, 1969, Govindaraj and Rouse, 1981, Wewerinke, 1986). It was proved that an early HMS used a human as a primary power source, as described by McRuer and Krendel(1962). Thus, the objective of HMS is to design a stable system and analyse how the system will behave with the presence of a human in the control loop (Bauckhage *et al.*, 2005). However, in such a system the interaction between human and machine is asymmetrical, due to fact that only the human learns the machine's characteristics in order to achieve the best performance (Harashima and Suzuki, 2006).

Although Tustin (1947) demonstrated that HMS results from a synthesis of human actions in controlling an electrically controlled turret of a tank, later, McRuer and Krendel (1959a) claimed that human characteristics and models vary among

researchers due to the adaptive, non-linear nature of human and other external factors, such as the environment. In other words, each application of machine manipulation will produce a different model of the human, because the human is a more complex system.

Although Tustin's work has some limitations in the methodology, which only involved tracking a moving target and adjusting the motor-driven turn-table, its main value lies in the conclusion that the human behaves as a linear servomechanism (Gaines, 1969). Thus, a new era of research into HMS began.

Indeed, Miller and Elkind (1967) found that HMS is distinguishable from the more general field of human factors and related fields such as human-computer interaction, computer science, mechatronics and human psychology. In other words, HMS itself involves cooperation among experts in various fields to study large, complex and dynamic systems that are usually partially automated, such as flying an airplane, monitoring a nuclear power plant or supervising a flexible manufacturing system. This enables them to build quantitative or computational models of the human-machine interaction as tools for analysis and frameworks for design.

Figure 2.1 shows an example block diagram of ordinary HMS for a tele-operation system using a wheeled mobile robot (WMR), as adapted from Hidaka *et al.* (2006). As shown in Figure 2.1 and explained earlier, HMS is a complex system that consists of a human and a machine. In this example, the WMR is the manipulated system and

the human is considered the controller, manipulating the WMR based on the image received from a wireless camera. Although both machine and human have their own characteristics, the whole process depends wholly on the human’s eyes, which function as a feedback system. The human brain translates the eyes’ ‘signal’ into body movements; more specifically it is the hand or leg that initiates and moves the WMR using an input device such as a joystick, a steering wheel, pedals or a keyboard.

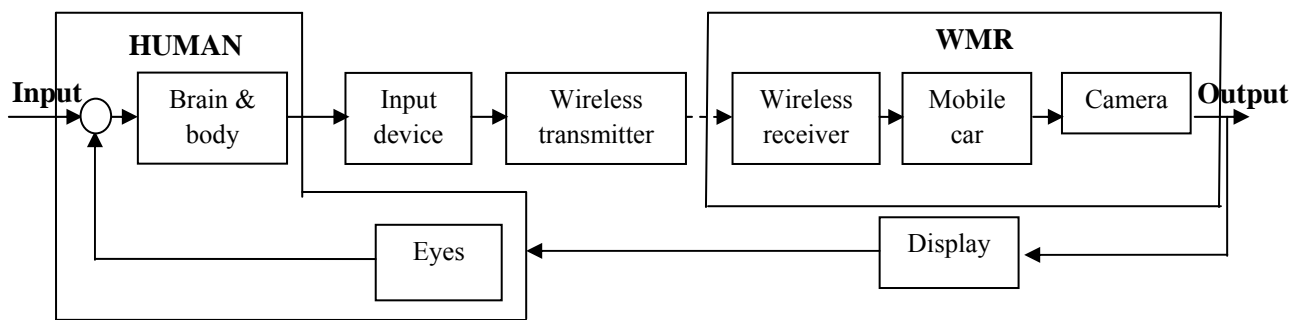

Figure 2.1: An example block diagram of HMS (Hidaka *et al.*, 2006)

Figure 2.1 also shows that ordinary HMS is a one-way relationship where only the human has to learn the machine’s characteristics and is responsible for any action taken. Hence, all burdens are on the human side and the machine is unable to adapt to any human actions or environment changes. In other words, the ordinary HMS was not designed to adapt and assist the human to improve their skill (Harashima and Suzuki, 2006). Thus, these limitations in HMS inspired researchers to improve and enhance the current system into a new system called Human Adaptive Mechatronics.

2.3 HUMAN ADAPTIVE MECHATRONICS (HAM)

2.3.1 DEFINITIONS

An understanding of the enhanced HMS concept is essential to design and achieve a high performance HMS which adapts to human characteristics and the environment. Therefore, the enhanced HMS system, known as Human Adaptive Mechatronics (HAM), was proposed in the Centre of Excellence (COE) research project in Tokyo Denki University, Japan and sponsored by the Japanese Ministry of Education, Sports, Culture, Science and Technology between 2003 and 2007 (Furuta, 2003, Furuta, 2004).

Many definitions of the Human Adaptive Mechatronics (HAM) concept have been proposed in the literature, yet it seems easy to identify the actual fundamental description of HAM (Furuta, 2003, Furuta, 2004, Kurihara *et al.*, 2004, Masamune *et al.*, 2004, Miyashita *et al.*, 2004, Suzuki *et al.*, 2004a, Suzuki *et al.*, 2004b, Igarashi *et al.*, 2005a, Igarashi *et al.*, 2005b, Igarashi *et al.*, 2005d, Suzuki and Harashima, 2005, Furuta *et al.*, 2006, Harashima and Suzuki, 2006, Kado *et al.*, 2006, Suzuki *et al.*, 2006b, Iwase *et al.*, 2006b), although many challenges remain unanswered (Suzuki, 2010). Furthermore, no other researchers used HAM terms until Furuta (2003) used them in the 42nd IEEE Conference on Decision and Control 2003 in Hawaii, USA.

According to Suzuki and Harashima (2005), HAM can be easily defined as intelligent mechanical systems that adapt to human skills in different situations, help improve human skills and assist HMS to achieve the best performance. This definition sounds

simple, but its implementation is complicated due to fact that an ordinary machine is unable to recognize a human. Moreover, this definition should be more comprehensive to determine the human role in the system. To illustrate this, Suzuki *et al.* (2004a) described HAM as the recognition of human characteristics by the machine to enable an appropriate reaction based on the human skill level and improve the skill of each individual. In other words, the machine has to learn human characteristics and adapt to the changes made by different human operators and the environment.

For a greater understanding, Gosselin (2006) defines an adaptive system as the ability to respond successfully to a new situation. Also, he defines an adaptive mechanical system as the ability to adapt to new external situations relying strictly on mechanical properties. In other words, an adaptive mechanical system is one in which some form of intelligence is embedded into the mechanics. In practice, adaptive mechanical systems are usually coupled with intelligent mechatronics systems.

Figure 2.2 shows the schematic diagram of HAM as proposed by Furuta (2004). The combination of three major fields with human intelligence is essential in order to realize the HAM system. Each field is related to each other. These fields are Human, Mechatronics and Control.

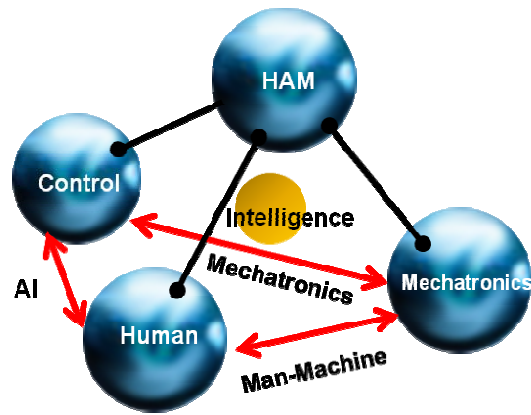

Figure 2.2: Schematic diagram of Human Adaptive Mechatronics (Furuta, 2004)

In the early stages of HAM, the project combined the efforts of 18 professors and experts, separated into three main groups: the Human Group, the Control Group and the Mechatronics Group (Furuta, 2004). Their primary goal was to establish the basic theories and principles of HAM. Although the core project developed the basic principles and applications, many challenges remain in respect of HAM’s technical, educational and commercial development (Suzuki, 2010).

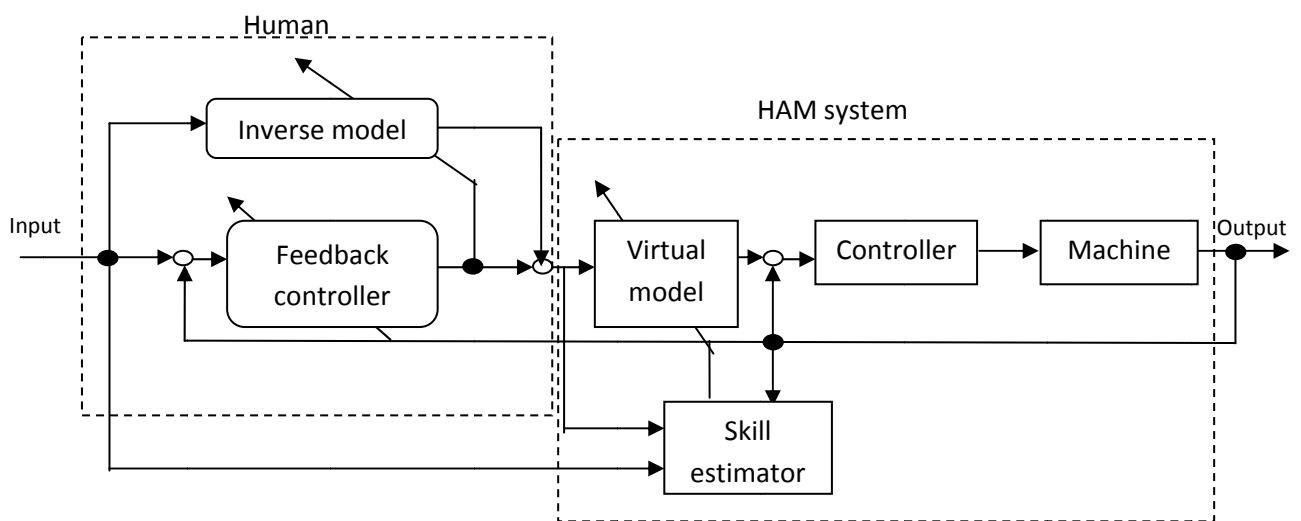

Figure 2.3: An example of Human Adaptive Mechatronics System. Adapted from Suzuki *et al.*, 2006b

Figure 2.3 shows an example block diagram of a HAM system, adapted from Suzuki *et al.* (2006b). Similar to HMS, the human is still considered the main controller and responsible for controlling the system. Since the inverse model is created when the human learns the dynamics of the machine, only the human is adapted to the machine's characteristics. However, the new HAM system brings the hope that the machine is also able to adapt to the human's characteristics, such as skill level. Therefore, the proposed HAM system consists of a skill estimator to estimate human skill based on input, current human characteristics and the virtual model as an ideal model.

2.3.2 ELEMENTS IN HAM

Furuta (2004) claim that HAM will not only design the systems that adapt to the skill of the user but will also result in methods to assist the user to improve the necessary skills for efficient operation of the mechatronics. The HAM concept was suggested because of the narrow approach of research into existing HMS. Previously, in most existing research into HMS, human and machine are dealt with separately. The main research theme of HMS is how the machine adapts to the environment, not to the human. Therefore, HAM will provide the platform for the machine to adapt to the human and environment together. However, the main challenge in HAM remains the recognition of human characteristics by the machine (Suzuki *et al.*, 2005d), because the human is considered to be a complex system.

Humans are inherently aware of their surroundings whether physical or social and seem to be able to intuitively judge the affordance of a situation, i.e. the possible number of actions in a particular environment (Igarashi, 2008, Baron and Kleinman, 1968). Therefore, in order to realize the HAM system, the following crucial elements are needed (Suzuki and Harashima, 2005):

- 1) Definition and quantification of human skill
- 2) Cognition of human behaviour by the machine
- 3) Assistance to the human by the machine
- 4) Change of the machine's function for total enhancement.

This thesis mainly deals with the first element, the quantification of human skill in various tasks using the proposed formula explained in Chapter 4.

2.3.3 SKILL IN HAM

Due to the ambiguous concept of skill, a general and comprehensive definition of skill in machine manipulation has not been found (Suzuki, 2010). Normally, the term 'skill' refers to the ability or proficiency to perform something well, whether it is comes from knowledge, practice, aptitude, experience etc.

However, in HAM, skill is defined as an ability to manipulate the machines accurately and quickly and to cope with emergency circumstances (Suzuki *et al.*, 2005a, Suzuki and Harashima, 2005). In other words, the ideal is to obtain the smallest error (when error is equal or almost equal to zero) with the fastest time when performing a task

using a machine. Consequently, this combination of conditions will produce the highest skill level in the human operator.

Furthermore, in order to study the HAM concept, Suzuki (2010) ranked six types of skill in manipulating the machine, from the highest hierarchy to the lowest, as follows:

L1) Skill in Cooperation: Conversation, negotiation and division of roles.

L2) Scheduling Skill: Planning of tasks and optimisation of work processes.

L3) Cognitive Skill: Recognition of circumstances and understanding of meanings.

L4) Task skill: Execution of segmented subtasks or actions.

L5) Skill for Voluntary Motion: Manipulation of interface devices and control of machine motion.

L6) Skill in Perception: Sensing and observation.

These skills are related to each other and important when a human performs any tasks using a machine. However, this thesis deals with the overall skill of human in manipulating the machine.

By understanding human skills, the intelligent machine, or simply the HAM machine, can distinguish and adapt to the individuality of different humans. Then, by using these differences, the machine can provide feedback or responds appropriately (Sasaki *et al.*, 2007). For example, if the human skill level is identified as high, then the HAM

machine only gives minimum assistance when necessary. However, for a human with a low skill level, the machine will provide maximum assistance in whatever conditions, whether the human requires it or not. As a result, the performance of the machine is improved, it is less time consuming to learn the machine operation and the productivity of the human is raised when the machine also adapts and assists the human's actions.

2.4 DRIVING, SKILL, PERFORMANCE AND EXPERIENCE

Driving is the most common example of manual control of complicated processes (Ertugrul, 2007), which involves dynamic interleaving and execution of multiple critical subtasks (Salvucci, 2006). Driving requires learning, knowledge, training, skills and experience on the part of the human in manipulating a vehicle. For safe driving, the human needs such skills as accelerating, steering, braking, making a u-turn, cornering, overtaking other vehicles and identifying the danger. Based on Xu *et al.* (2002), these skills can be analysed using event analysis to define the performance of the human control strategy. Therefore, the human needs a license to drive and this requires the human to spend adequate time in training and developing driving skills.

Furthermore, the performance also related to the skill. The skills can be learned but not the performance. Although the performance is usually measured based on skill, but the high skilled person is not always performed better than others. The easiest example is in football game, any player in any big club might have the skill in playing football before signing in, but he is not guaranteed to perform well in every game.

They still need training, experience and teamwork to win the games. Similar to the drivers, the skills that they have are considered as advantage in helping them to perform better during driving (Ivancic *et al.*, 2000).

On the other hand, experience of driving does not mean expertise and may not always be beneficial (Duncan *et al.*, 1991). Although the human has enough experience in driving, the risk involved in an accident is still high because the human is exposed to other humans' errors. In other words, in most cases, driving is all about human actions and the vehicle is just a manipulated machine that is unable to prevent human error. If an adaptive mechatronics system is implemented in the car, the insurance companies might blame the car in the event of an accident. However, the cost of insurance maybe increases in line with the features. The question of legal responsibility may become a complex issue when HAM systems are implemented in real vehicles. Vehicle manufacturers currently are reluctant to introduce systems which take control away from the driver for reasons of legal liability in the event of an accident.

Modern vehicles are usually equipped with active and passive assist systems, such as auto cruise systems (Arai and Fujita, 1998), anti-lock braking systems (Miller *et al.*, 1994), parking assist systems (Tanaka and Iwata, 2005) and electronics stability control systems (Milot, 2006). However, these systems tend to annoy and distract the human driving the vehicle (McCall and Trivedi, 2007). Furthermore, these systems do not adapt to human skill automatically and only provide assistance when the human activates the feature buttons. In other words, all machine actions still depend on

human decisions. There is no learning and understanding process by the machine to differentiate between humans or a changing environment.

2.5 HUMAN MODEL

Human models depend on the inputs, constraints and limitations of the methodologies. According to Harashima and Suzuki (2006), these criteria reflect the validity and reliability of the resulting model in the system. However, modelling humans is very complicated because humans may adapt to the situation through a learning process and they are not a time variant (Igarashi *et al.*, 2006). The following sections discuss established selected human models that are used widely, such as the quasi-linear model, the optimal control model, the linear parametric model and the intelligent model.

2.5.1 QUASI-LINEAR MODEL

McRuer and Krendel(1959) found that many non-linear systems give similar responses to inputs as linear systems. Their observation leads to the definition of the human operator model, which is non-linear. Hence, the quasi-linear human model was proposed, as shown in Figure 2.4.

Based on Figure 2.4, the quasi-linear model describes the human operator with a linear differential equation and a non-linear part for noise and other disturbances in the system. The non-linear part is called a remnant and is described by statistical quantities (McRuer and Jex, 1967). Although this model can provide good intuition

about system behaviour, it cannot handle more than one input (Sheridan and Ferrell, 1981).

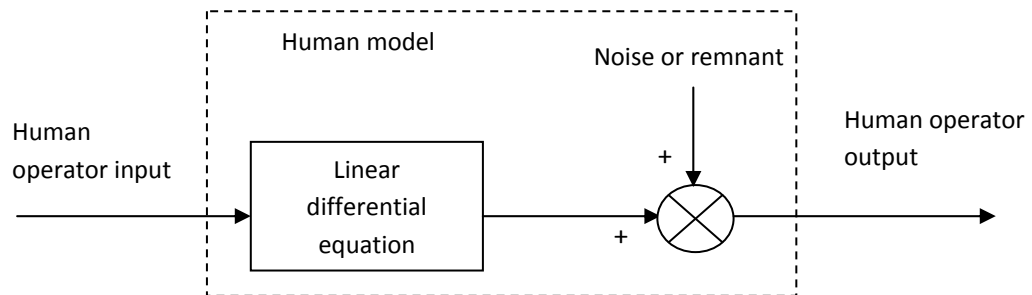

Figure 2.4: The quasi-linear human model

(McRuer and Krendel, 1959)

2.5.2 OPTIMAL CONTROL MODEL

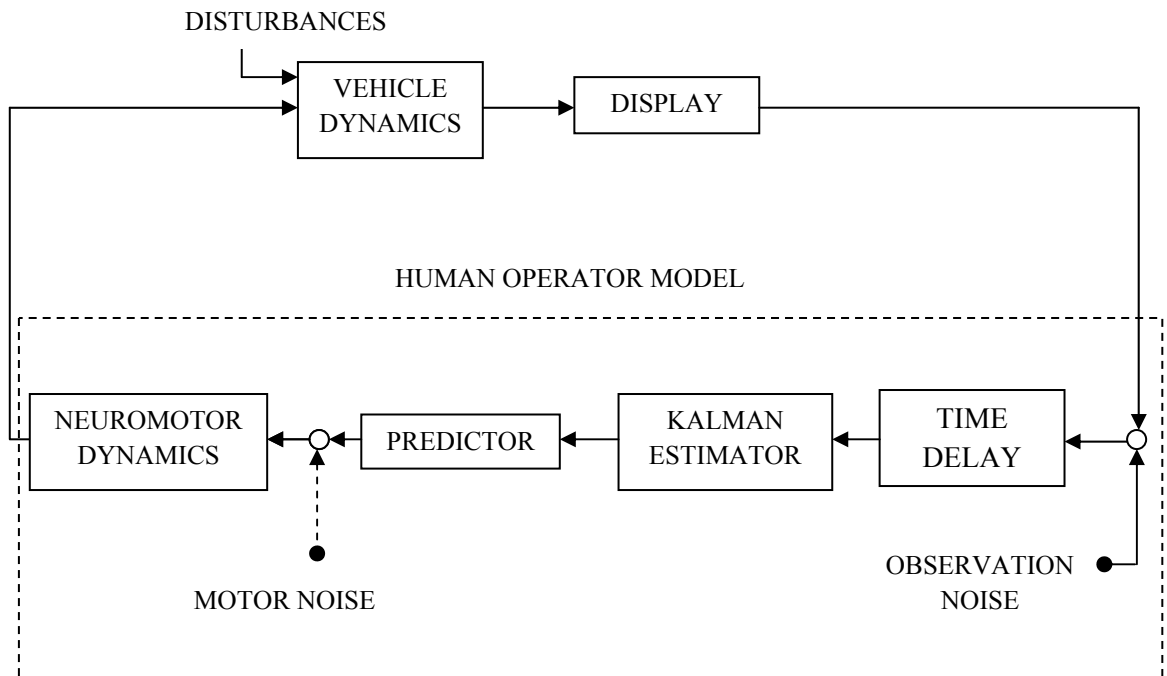

Figure 2.5: Optimal human model (Kleinman *et al.*, 1970)

Kleinman *et al.* (1970) propose an optimal control model to represent the skilled, motivated and well-trained human operator, as shown in Figure 2.5. This model assumes that the operator behaves in a near optimal manner, trying to minimise the quadratic performance index that might consist of tracking error, error rate etc.

This model is suitable for complex machine dynamics and multi-input multi-output systems. However, this model is a high order, complicated mathematical model and can sometimes be over-parameterised even for simple systems.

2.5.3 LINEAR PARAMETRIC MODEL

Ertugrul(2007) found that this model is a new approach to the human operator modelling problem using parametric system identification techniques. Examples of this model are AutoRegressive with eXogenous inputs (ARX), AutoRegressive Moving Average (ARMA), Stochastic Switched ARX (SS-ARX) and AutoRegressive Moving-Average with eXogenous input (ARMAX). Example applications of this model can be found in Pilutti and Ulsoy (1999), who tried to obtain a linear constant coefficient model of drivers to model driver tiredness in long-distance driving.

Even though parametric models such as the ARX and ARMAX models could pass the goodness-of-fit in terms of correlation tests, they exhibit uncertainties and the parameters of the models vary greatly from operator to operator (Ertugrul, 2007, Suzuki *et al.*, 2005e).

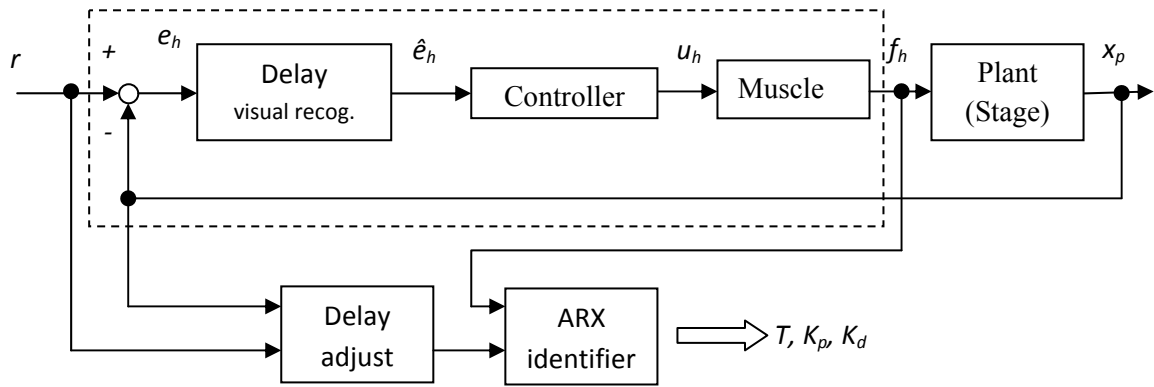

Figure 2.6: Example of human control model using ARX
(Suzuki *et al.*, 2006)

Figure 2.6 illustrates an example of ARX to estimate the human model, as presented by Suzuki *et al.* (2006a). This model considers the human model as a PID controller, since a human regulates the time delay between the input and output response. Since the ARX model can easily include the time delay, it is convenient to model the human because the human controller is considered to be a time-varying system.

2.4.4 INTELLIGENT MODEL

According to Ertugrul (2007), this model has a judgment and learning capability similar to human characteristics. Examples of this model include the fuzzy logic system (FLS), the neural network (NN) and the adaptive-network-based fuzzy inference system (ANFIS).

Shaw (1993) used FLS in human modelling since the 1990s. However, FLS has many design parameters, thus it takes a long time to design, tune and debug (Ertugrul, 2007). An and Harris (1996) found that the learning capability of NN attracted attention for mapping the input-output relations of human operators. But as a black-box model, NN may be not easy to debug.

As a consequence of these situations, Jang (1993) proposed ANFIS, which has the characteristics of both NN and FLS. Based on Ertugrul(2007), ANFIS is more suitable for human decision-making strategies and has a small number of parameters to be determined, thus providing faster processing.

2.6 COMPARISONS AMONG SELECTED HUMAN MODELS

Based on the literature, each human model has been compared in terms of its capabilities and limitations; this is summarised in Table 2.1.

Table 2.1: Human model comparison

Human Model	Capabilities	Limitations
Quasi-linear	<ul style="list-style-type: none"> • Provides good intuition about behaviour of the system. 	<ul style="list-style-type: none"> • Cannot handle more than one input.
Optimal Control	<ul style="list-style-type: none"> • Can be related to human information-processing behaviour. • Suitable for complex machine dynamics. • Can handle multi-input multi-output (MIMO) systems. 	<ul style="list-style-type: none"> • Complicated mathematical equations. • High-order. • Over-parameterised for simple systems.
Linear Parametric	<ul style="list-style-type: none"> • Could pass the goodness-of-fit in terms of correlation tests. 	<ul style="list-style-type: none"> • Model exhibits uncertainties. • Parameters vary greatly from operator to operator.
Intelligent	<ul style="list-style-type: none"> • Small number of parameters. • Provides fast training. 	<ul style="list-style-type: none"> • Difficult to determine the rules.

2.7 RESEARCH-RELATED HAM

Nowadays, researchers in the area of HAM play a major role in establishing it as a new innovative approach in many applications, such as the Haptic System (Suzuki *et al.*, 2006b, Suzuki *et al.*, 2005c, Suzuki *et al.*, 2005d, Suzuki *et al.*, 2006a, Suzuki *et al.*, 2006c, Miyashita *et al.*, 2007, Takaiwa and Noritsugu, 1999, Kurihara *et al.*, 2004), the scrub nurse robot (Masamune *et al.*, 2005, Masamune *et al.*, 2004, Yoshimitsu *et al.*, 2005, Sadahiro *et al.*, 2007, Miyashita *et al.*, 2004), tele-operation systems (Igarashi *et al.*, 2005d, Igarashi *et al.*, 2005a, Igarashi *et al.*, 2005c, Igarashi *et al.*, 2005b, Kofman *et al.*, 2005, Suzuki *et al.*, 2005b, Suzuki *et al.*, 2005d, Suzuki *et al.*, 2005e, Igarashi *et al.*, 2006, Maeda *et al.*, 2006, Saida *et al.*, 2006, Furuta *et al.*, 2007, Maeda *et al.*, 2007, Sasaki *et al.*, 2007), human alertness systems (Ueno and Uchikawa, 2004, Suzuki *et al.*, 2005e, Hyrskykari, 2006, Sugita *et al.*, 2007, Suzuki *et al.*, 2007), intermittent control systems (Iwase *et al.*, 2005, Iwase *et al.*, 2006b, Iwase *et al.*, 2006a, Bien *et al.*, 2005), surgical support systems for laparoscopic surgery (Masamune *et al.*, 2005, Sadahiro *et al.*, 2007, Masamune *et al.*, 2004, Miyashita *et al.*, 2004) and inverted pendulum systems (Kado *et al.*, 2006, Furuta and Xu, 2001, Furuta, 2003). In the following sections, three examples of research related to HAM that are important to this thesis are reviewed.

2.7.1 TELE-OPERATION SYSTEM IN HAM

Tele-operation is a task of taking control a machine from a distance via remote control (Kofman *et al.*, 2005). It is often necessary in unstructured dynamic environments where human presence at the site is undesirable. One of the advantages of a tele-

operation is the ability to include valuable human skill in global recognition, planning and prediction (Igarashi *et al.*, 2005a).

Igarashi *et al.* (2005c) found that limited information may disturb human ability and cause misrecognition. To reduce the mistakes, some researchers have studied the graphical user interface (GUI), which includes functions to emphasize important information. But most still do not emphasize the variation in operators' characteristics including individuality. In other words, the information required by the operator, especially in complicated tasks, is not constant. For example, a beginner in robot operation may be confused by too many instructions and easily make mistakes. On the other hand, the extensive knowledge of the expert operator results in a higher operation performance. Figure 2.7 shows an example block diagram of a tele-operation system, adapted from Hidaka *et al.* (2006). The human acts as the controller of the WMR using a remote input device such as a joystick or steering wheel.

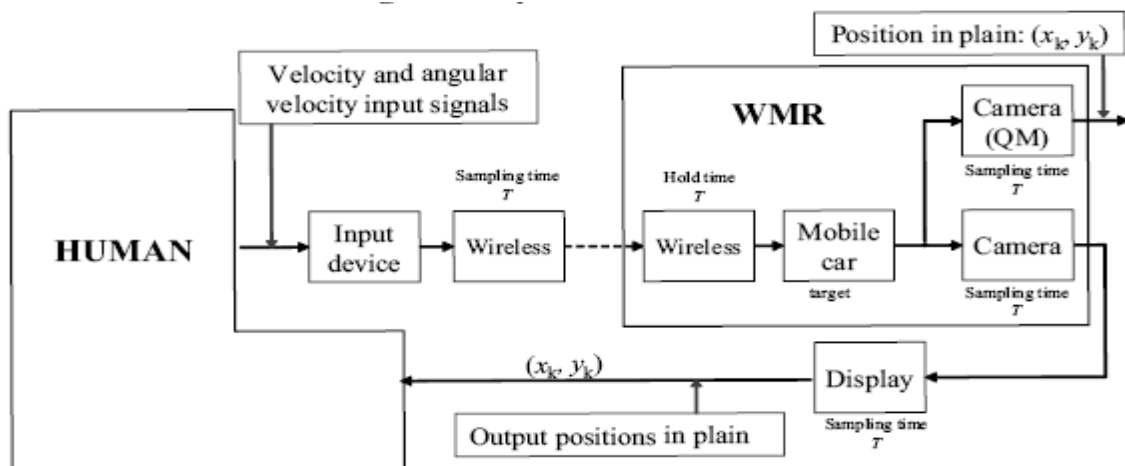

Figure 2.7: Block diagram of a tele-operation system (Hidaka *et al.*, 2006)

Saida *et al.* (2006) state that two types of human skill are needed in tele-operation: machine manipulation skill and environmental cognition skill. General manipulation of a machine, however, needs both cognitive skill and operational skill. Therefore, the total efficiency of the whole system cannot be enhanced without adequate judgement according to the circumstances. On the other hand, environmental cognition skill includes the way in which humans recognize the surroundings according to the information received from the camera and displayed on a monitor. Indeed, environmental cognition is considered as an external factor related to skill (Maeda *et al.*, 2007).

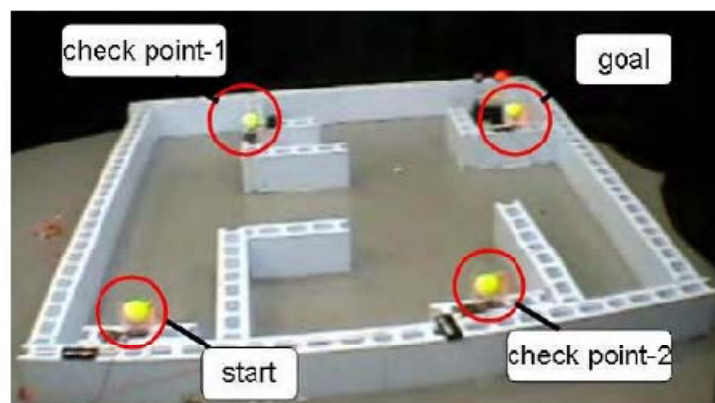

Figure 2.8: Experimental set-up of Maeda *et al.* (2007)

In order to investigate operational skill, Maeda *et al.* (2007) performed an experiment using a WMR in a maze task. In their experiment, the human subjects controlled the WMR using a wireless joystick. A camera was mounted on the WMR to give an image around it with an angle view of 70°. The human subjects were able to control the speed of WMR in real time by using the joystick command. The position of the

WMR was measured by a motion capture system with a sampling time of 16 ms. Moreover, the experiment used only four human subjects, who were instructed to control the WMR by watching the camera image on a monitor that had a view 1 m ahead. The human subjects manoeuvred the WMR from a start point to a goal in a simple maze by passing the intermediate checkpoint, as shown in Figure 2.8. In order to gain skill for the process, the task was repeated 10 times within 20 seconds for each trial. For analysis, they identified the human controller using the ARX model. As a conclusion to this experiment, Maeda *et al.*(2006) simply confirmed that the human subjects gained skill in WMR operation: the time taken to complete the task decreased with successive trials.

2.7.2 HUMAN CALIBRATION FOR HAM

According to Igarashi (2008), optimum human machine operation is achievable when the human dynamic model is almost similar to the machine dynamic. Therefore, in his research, Igarashi conducted an experiment using a computer simulation, as shown in Figure 2.9(b), to propose a calibration technique that brings the dynamics of the operated machine closer to the dynamic of the human as an operator. Figure 2.9(a) also shows the experimental set-up used by Igarashi, where the human subjects use a steering wheel to manoeuvre a simulated vehicle in the OpenGL 3D computer graphic environment.

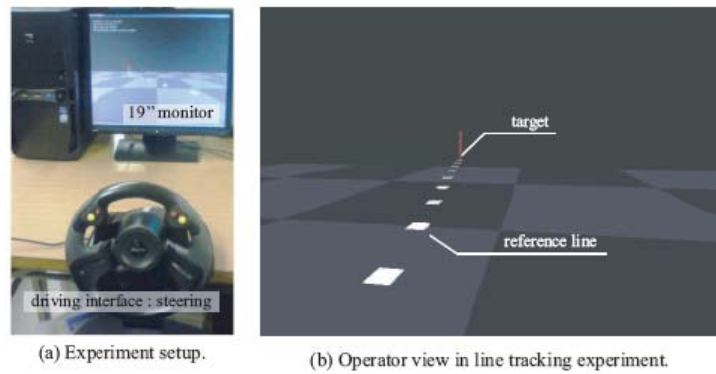

Figure 2.9: Experimental environment of Igarashi (2008)

Igarashi categorises the errors into two types, the following error e_ϕ and the target directional error e_d , as illustrated in Figure 2.10. The following error is an error in the Y-axis that is calculated from the reference line to the centre of the vehicle. The directional error is measured from the angle of orientation between the target and the vehicle. Igarashi modelled the human as the PD controller to simplify the calibration process.

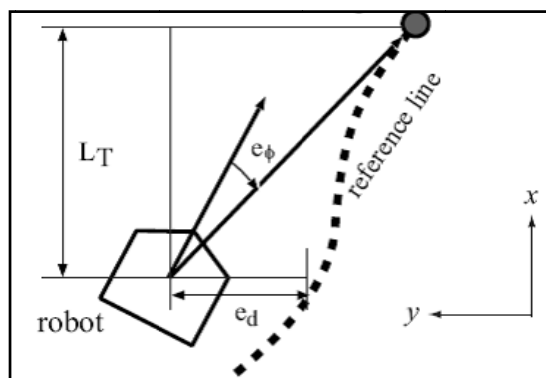

Figure 2.10: Errors defined by Igarashi (2008)

Although this thesis is identical to Igarashi’s work in terms of experimental set-up (more details in Chapter 3), there are some differences in terms of experiment features, as shown in Table 2.2. Also, there are significant differences in terms of aim and objectives of the experiment; Igarashi’s work focused on calibration techniques and this thesis focuses on skill evaluation in different tasks.

Table 2.2: Comparisons between Igarashi’s experiment and this thesis experiment

Feature	Igarashi’s experiment	This thesis experiment
No. of trial(s)	Two (with and without calibration)	Five (for every track)
No. of subject(s)	8	20
Track type	Randomly designed using the combination of sine waves	Five pre-defined tracks
Speed	Constant	Variable
Use of pedals	No	Yes
Time for each trial	Three minutes. *No time recorded	Unlimited. *Time is recorded
No. of error(s)	Two: Following and directional errors	One: Tracking error

2.7.3 PURSUIT TRACKING FOR THE HUMAN

Another research study that is used as a main reference to this thesis is the pursuit tracking experiment performed by Ertugrul (2007) to obtain data from human operators using system identification theory. The goal of her research was to find a simple dynamic model for the prediction of human operator actions in a manual control system.

In Ertugrul's experiment, the subjects had to follow the input signal that appeared on the screen by using an optical USB mouse. Ertugrul set the mouse motion speed to medium and constant throughout the experiment. In terms of the input signal, she used the Pseudo Random Binary Signal (PRBS), as shown in Figure 2.11, because she claimed that it gave better results than other input signals such as the sum of sine waves and filtered white Gaussian noise. Moreover, PRBS is the most feasible input signal in system identification theory.

In terms of software, Ertugrul (2007) used the MATLAB System Identification Toolbox to design the experiment and analyse the models. She used 30 human subjects selected from among upper or intermediate and advance level computer users. Before the start of the experiment, the subjects were shown the 60-second long signal but responded instantaneously to the signal when it appeared on the screen during the run. Hence, the system was considered to be pursuit tracking with no preview for a zero-order system. The zero-order system gain is the ratio between the mouse deflection and the pointer deflection.

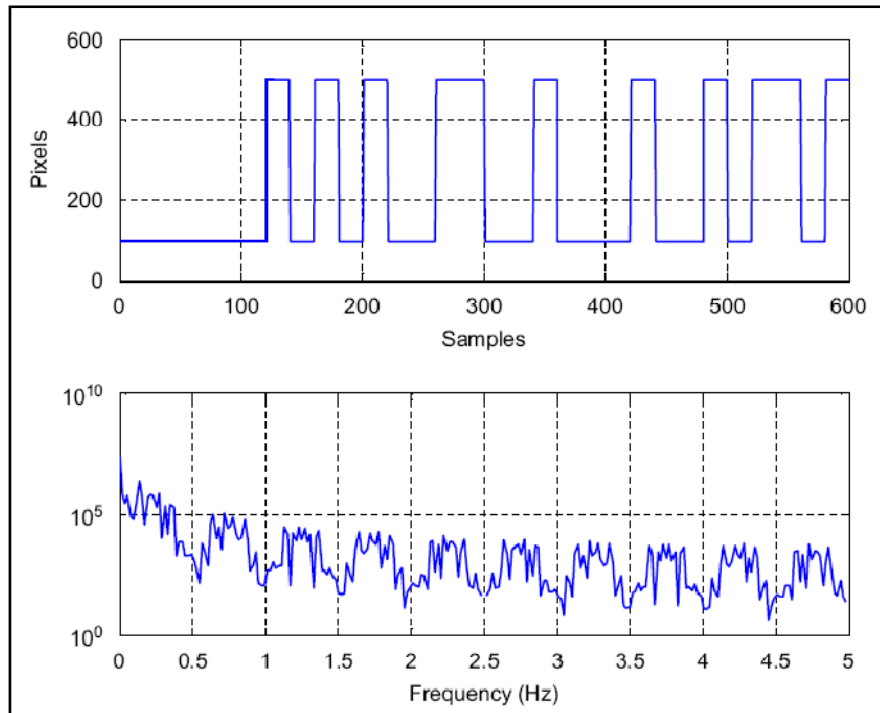

Figure 2.11: The PRBS and its frequency spectrum that was used as the input signal by Ertugrul (2007)

For estimation and validation purposes, the human subjects were asked to follow the input signal twice. The error was determined as the difference between the input signal and the recorded response of the human subject. The human responses were identified using the ARX model and ANFIS. Both models were investigated and compared for simple and fast implementation to predict the response of human subjects. As a conclusion to this work, Ertugrul (2007) claims that the computer simulation proved to be a valid tool for collecting data in HMS. Also, she confirmed that ANFIS provided much better prediction results than the ARX model.

2.8 SUMMARY

This chapter provides a literature review covering the overview of the Human Machine System (HMS) and detail about the Human Adaptive Mechatronics (HAM) system in terms of definition, elements and skill required. It can be seen that HAM is essential in order to enhance the relationship between human and machine in HMS. Related issues concerning driving and humans are also discussed, as well as the selected human models. Finally, the important research that related to HAM and this thesis is presented, such as tele-operation systems, human calibration and pursuit tracking.

In addition, Table 2.3 summarizes the important developments related to HAM found between 2003 and 2010. Based on Table 2.2, it can be seen that most experiments were done using computer simulation, such as line tracking, point-to-point tasks and pursuit tracking. In other words, it shows that the HAM system is still far from the real applications that have embedded it into a system and that it is only suitable to test in a simulated environment. Thus, this thesis also uses a computer simulation as part of the methodology.

Table 2.3: Summary of literature review related to HAM

Note: J – Journal, C – Conference, CS – Computer Simulation, H - Hardware

No.	Author and Type	Year	Method	Features	Human Model	Control Device	Performance Index	Additional info	Applications	No. Of Subjects	No of trials
1	Igarashi (J)	2008	Human-machine manoeuvring system: Line tracking (CS)	Human operates without awareness	PD controller	Steering (R220, Saitek)	Following-error & target-directional error	Proposed the calibration to improve machine operation	Tele-operation	8	1 x without calibration 1 x with calibration
2	Ertugrul (J)	2007	Pursuit tracking using mouse (CS)	No preview for zero order system. Visual as feedback. Input: Pseudo Random Binary Signal (PRBS)	ARX and ANFIS	Mouse	Error between cursor and signal	Fitt's Law ($\pm 2\%$) PRBS as input	N/A	13	2
3	Maeda <i>et al.</i> (C)	2007	Maze-task (H)	Operational skill investigated	ARX and dual ARX model	Wireless joystick	Time	n/a	Tele-operation wheel mobile robot	4	10
4	Furuta (C)	2003	n/a	n/a	n/a	n/a	n/a	Overview of HAM system	Furuta Pendulum	n/a	n/a
5	Furuta <i>et al.</i> (C)	2007	X-Y stage (joystick) as mass and damper movement (CS)	Screen displayed the reference and operator disk. Linear and circular motion. Hold the grip and manipulate it at three different positions	Kawato-Suzuki and Furuta model	Two DOF joystick	N/A	Dynamic of display is neglected. Human dynamics include the feedback	N/A	2 (unskilled and skilled operator)	3
6	Tervo <i>et al.</i> (C)	2009	Wireless Joystick Control (CS + H)	Use Wireless Sensor Nodes. Two-axis joystick	PD controller	Joystick	Time Error of angle	More to propose an application that suitable for HAM	Laboratory-scale trolley crane	1	6
7	Suzuki <i>et al.</i> (C)	2005	Haptic system (CS)	Force/vision interactive Two DOF x-y stage Use force sensor Point-to-point task	PD and time delay ARX model	Two DOF joystick	Error between pointer and target	Monitor displays a pointer based on grip position in real time	n/a	10 for determine time delay 2 for test assist control	1 PTP = 1 trial 100 for time delay 50 for assist control

Table 2.3: Summary of literature review related to HAM (cont.)

Note: J – Journal, C – Conference, CS – Computer Simulation, H - Hardware

No.	Author and Type	Year	Method	Features	Human Model	Control Device	Performance Index	Additional info	Applications	No. Of Subjects	No of trials
8	Kurihara <i>et al.</i> (C)	2004	Haptic system (CS)	x-y stage real time monitor PTP control	PD and time delay ARX model	Two DOF joystick	Error between pointer and target	Future: Need to define practical skill-level. Did not measure the beginner and expert and analyse the learning process. Assist system: Feeling of force	N/A	10 for determine time delay 2 for test assist control	1 PTP = 1 trial 100 for time delay 50 for assist control
9	Tervo <i>et al.</i> (J)	2010	Cut-to-length forestry machinery (H)	Human skill evaluation in working machines during normal work	n/a	Joystick	Metric of sequence tasks	Skill evaluation via task sequence recognition by hidden Markov model	Mechanized timber harvesting and forwarder	3 for forwarder tasks 4 for forest harvester	2
10	Itoh <i>et al.</i> (C)	2006	Manual Control Experiment (CS)	Longitudinal Control of Aircraft	PID	n/a	Tracking error	Propose Human As a Control Module (HACM) consists of Human, Controller and Arbiter	Pilot Induced Oscillation (PIO)	2	1
11	Suzuki <i>et al.</i> (C)	2008	Bimanually moving grips (CS)	Track a reference marker for each hand by moving the grip. Divided two groups of subjects: without mechanical assistance and training guided	n/a	Dual x-y stages (Joystick)	Tracking error	Determine the learning process in bimanual coordination	n/a	12 (6 per group)	20

Table 2.3: Summary of literature review related to HAM (cont.)

Note: J – Journal, C – Conference, CS – Computer Simulation, H - Hardware

No.	Author and Type	Year	Method	Features	Human Model	Control Device	Performance Index	Additional info	Applications	No. Of Subjects	No of trials
12	Sasaki <i>et al.</i> (C)	2007	Line tracking experiment (CS)	Virtual hovercraft operation in 3D CG environment. Follow the centre line as fast as possible	N/A	Joystick	Accuracy (tracking error) and quickness (task achievement time)	Analyse the progress of human learning. Classify the skill level based on error and time. Measure the drift corner. Used NN to estimate the operator's control characteristics	Hovercraft system	8 beginners 1 expert	10 laps
13	Sadahiro <i>et al.</i> (C)	2007	Laparoscopic operation (H)	Measure skill using Centre of Pressure (COP)	n/a	Medical instruments such as forceps, scissor	Time and accuracy	Three training tasks performed for beginner: Pegboard, Cutting and Suturing. One training task for novices and experts: Combination of pegboard and suturing	Scrub Nurse Robot System	3 beginners 2 novices 2 experts	70
14	Suzuki <i>et al.</i> (J)	2006	HAM haptic device test (CS)	Manipulate a grip. The operator's force measured. Monitor displayed the PTP tasks	PD and time delay ARX model	x-y stage grip (joystick)	Error between pointer and target	Focus on Human Adaptive (HA) mechanical unit	n/a	10	100 (1 PTP = 1 trial)
15	Igarashi <i>et al.</i> (C)	2005	Mouse tracking display (CS)	Background are changed colour	n/a	Mouse	n/a	Proposed adaptive user interface. Human sensitivity evaluation based on colours	General HAM-GUI	1	2200

CHAPTER 3

METHODOLOGY

3.1 INTRODUCTION

This chapter examines the experimental approaches used in this research to clarify its central questions about the effects of skill, track patterns, disturbances and experience in human machine system. These approaches enable exploration of the machine ability to understand the human characteristics and provide the assistance for human to achieve the best performance.

This chapter describes the methodology used in this research. It begins with a flowchart that shows the overall steps in achieving the objectives of the research. Then, it describes the reasons behind the choice of software used. This chapter also explains about the graphical user interface (GUI) of three designed programs, the method in measuring the error, the experimental setup, the hardware, features of human subjects and method to collect data.

3.2 RESEARCH METHODOLOGY

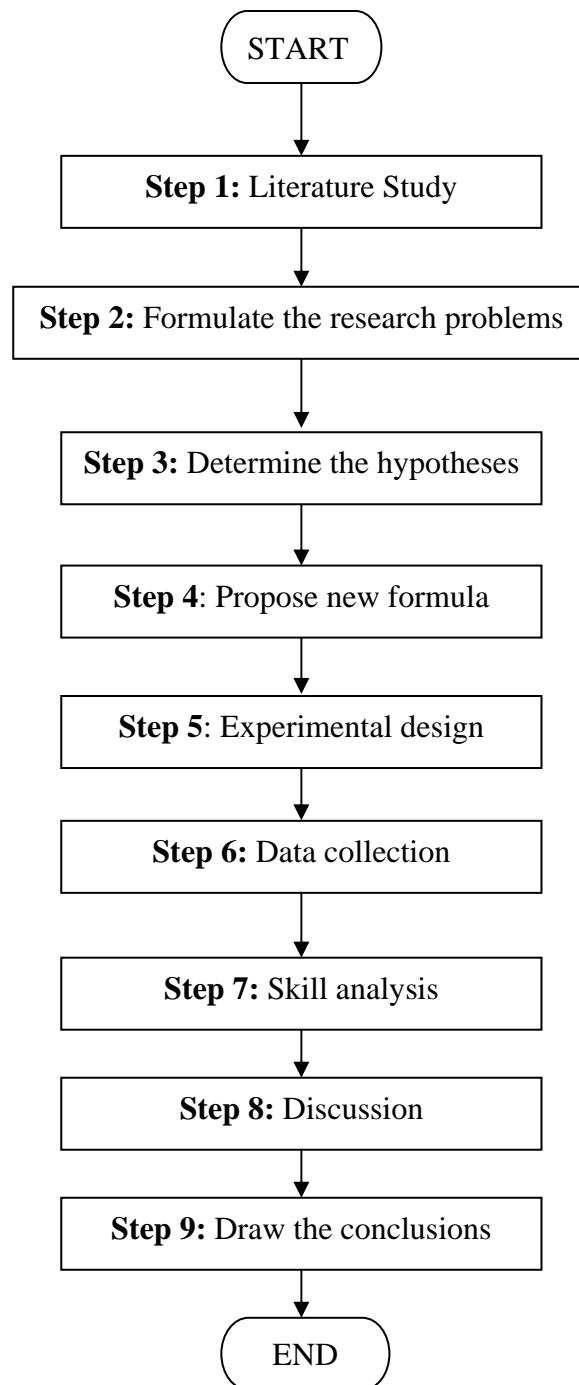

Figure 3.1: Flowchart of overall methodology

Overall, this research involved nine steps of methodology in order to accomplish the objectives as shown in Figure 3.1. Firstly, **Step 1** and **Step 2** consist of gathering the literature, analyzing the literature and developing the

idea based on problem identification. These two steps are explained detail in Chapter 2. Then, **Step 3** is generally described in Chapter 3. This step is not only important in giving the expected answers that will obtain from this research but also drives towards the right direction.

Step 4 is explained detail in Chapter 4. **Step 5** and **Step 6** are described in Chapter 5 and 6. Then, **Step 7** and **Step 8** are detailed in Chapter 7. Lastly, **Step 9** is explained in the last chapter of this thesis.

The general hypotheses for this thesis are determined below. However, the specific hypotheses of each experiment are described in Chapter 5 and Chapter 6, respectively.

The main hypothesis is:

For effective use in HAM systems, human driving skill can be quantified using tracking error and elapsed time.

Secondary or working hypotheses are:

1. Tracking error has a relationship with elapsed time.
2. Elapsed time and tracking error are expected to decrease after a number of trials.
3. Tracking error is related to the features of tracks.
4. Tracking error is also related to the conditions of the experiment.
5. Human skill is improved gradually after several trials.
6. Experienced drivers or gamers are better than others.

3.3 CHOICE OF SOFTWARE USED

As part of the experiment, this research involved the process of designing and creating the graphical user interface (GUI) by using appropriate software.

Therefore, Microsoft Visual Studio is chosen based on the factors below:

- i) Microsoft Visual Studio is the next iteration in the continual evolution of a best-of-breed integrated development environment (IDE) where the various components fit together in a cohesive way to provide an efficient tool set with everything was easily accessible (Horton, 2008).
- ii) Microsoft Visual Studio is also easy to use in programming windows based applications.
- iii)The speed of this software also higher than other software such as MATLAB.
- iv)This software also consists of one comprehensive environment, where it inherited many features and attributes of various development tools.
- v) This software can assemble the entire GUI for an application graphically and have all the code that creates it generated automatically.
- vi)This software is able to develop the Windows Form applications with little, or in some cases, no explicit code of writing (Randolph and Gardner, 2008).

3.4 GRAPHICAL USER INTERFACE (GUI) DESIGN

Three GUIs are designed in order to accomplish the objectives of each experiment. The first program, known as the MapMaker, is used in designing the tracks and comparing the tracks with the paths. Then, the second program, known as the Car Driving Simulator, is mainly used to collect the data from human subjects in experiments. Lastly, the Error Measurement program is

used to calculate the error between the paths of each subject and the actual tracks. Therefore, this section explains the features of each program in detail.

3.4.1 MAPMAKER

This program is created to simplify the track design process. However, this program is only used as pre-experimental tool and is not intended for human subjects. The program lets the users design a desired track by using ‘click and drag’ function embedded in a computer mouse.

The users can draw any tracks in any forms or patterns, whether it is a straight line, a circular, an elliptical, a square, a triangular, a freeform or any shapes that might be. Example of created track is shown in Figure 3.2. In other words, the track pattern is totally depends on the users consideration. Nevertheless, the users have to start draw it from point X, which is also the start point in the Car Driving Simulator, as shown in Figure 3.2. Furthermore, point X is located in coordinate (250, 0, 0) based on x , y , z axes as shown in Figure 3.3.

MapMaker displays the track from top view and in two dimensions (2D). For this program, the horizontal axis is the z -axis and the vertical axis is the x -axis, in order to synchronize with other programs.

This program also displays the green colour line for the created track. There are ‘Start’ and ‘End’ signs that show the initial and final point of the track, respectively. In addition, the created track is digitalized based on coordinate x and z . These coordinates can be saved in text file format and the example of this file is depicted in Figure 3.4. Each point is saved in following format:

<Coordinate-z>, <Coordinate-x>

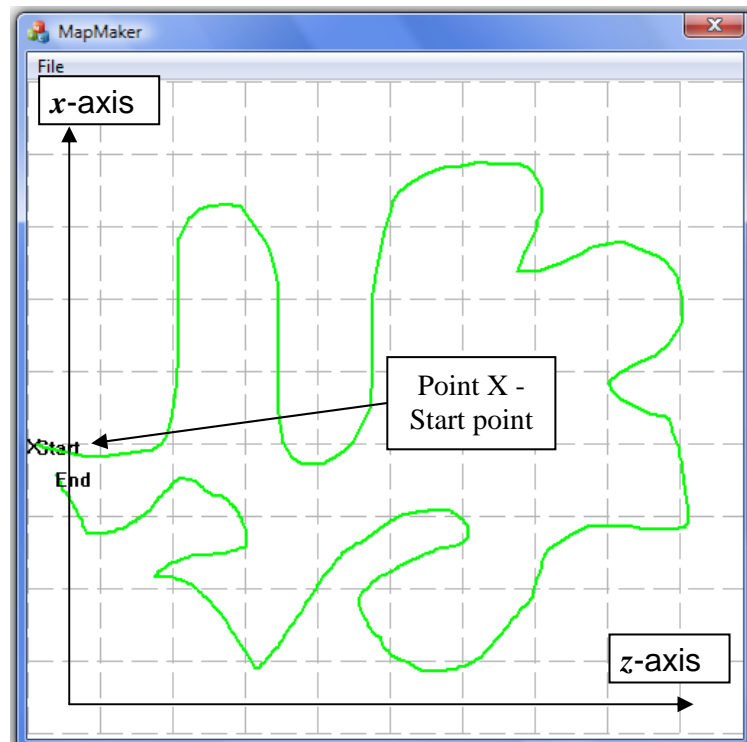

Figure 3.2: Example of track pattern created in Mapmaker.

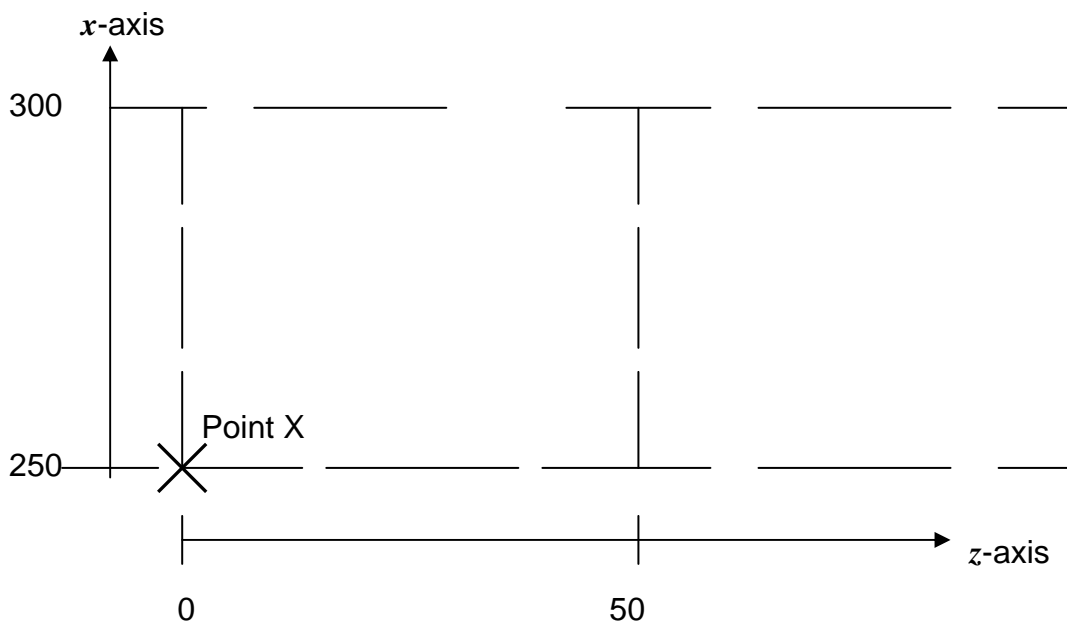

Figure 3.3: The point X on x and z axes.

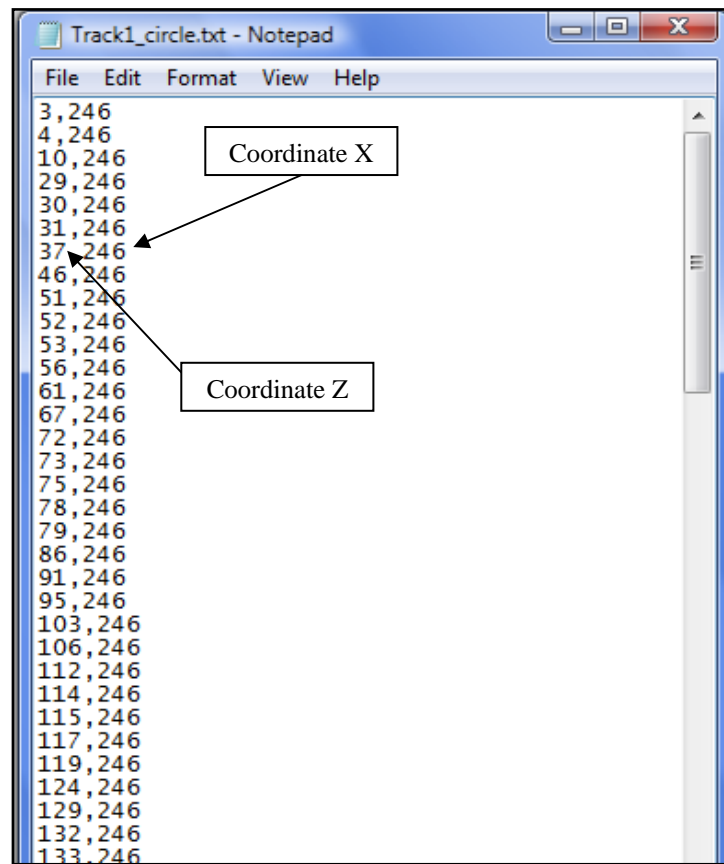

Figure 3.4: The example of coordinates of X and Z saved in text file.

The features of this program are as follows:

- a) The drawing space is 90 blocks consists of 9 blocks for x -axis and 10 blocks for z -axis. Each block size is 50 units x 50 units. Therefore, the range for z -axis is between 0 and 500 units. Also, the range for x -axis is between 0 and 450 units.
- b) The program has the file menu as shown in Figure 3.5, such as ‘**Clear Map...**’ to delete the track that currently displayed, ‘**Open Map...**’ to open the existing track file, ‘**Save Map...**’ to save the created track in the hard drive, ‘**Open Path...**’ to open the path that created in the Car Driving Simulator and ‘**Exit**’ to close the program.

c) In addition to its features, the Mapmaker program is also useful to compare the track in green colour with the subject's path in red colour, as shown in Figure 3.6. This feature is important to show the first impression of subjects' performance in terms of error that later will be measured in separate program.

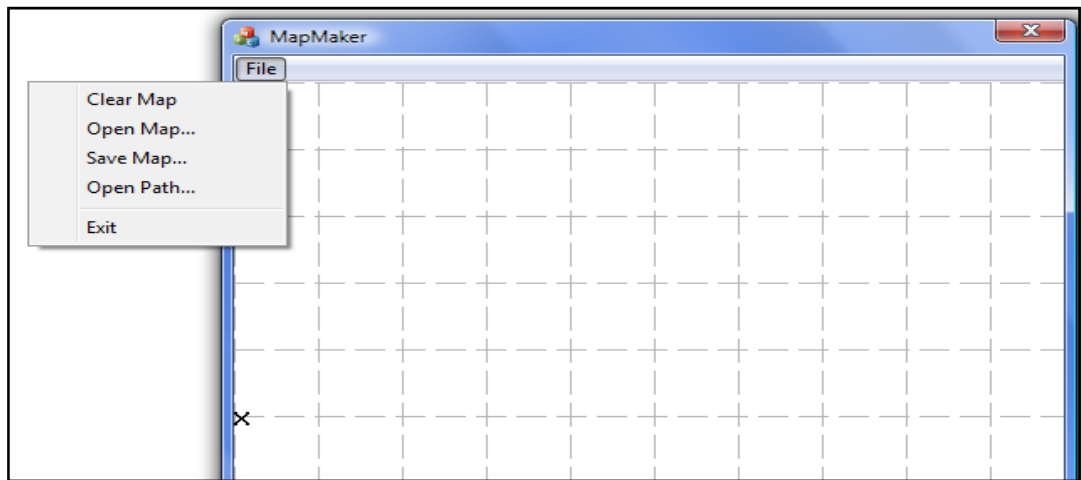

Figure 3.5: File menu in the MapMaker.

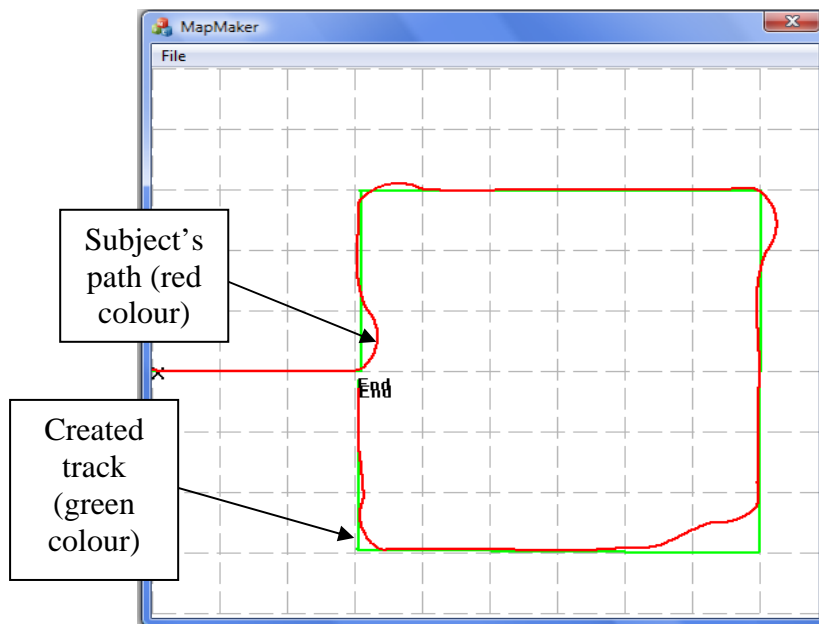

Figure 3.6: MapMaker can be used to compare the track and the path.

3.4.2 CAR DRIVING SIMULATOR

There are two choices of driving domain exist in experimental work, which is simulated driving and real driving (Y. Xu *et al.*, 2002). In this research, the simulated driving is selected. The reasons of this choice are stated below:

- i) The human subject must not be injured or harmed in any way during the experiment. In other words, the safety of human subject is very important in this case.
- ii) The human should have previous experiences or at least understand the way to handle the steering and pedals, which will help in completing the experiment successfully. In other words, if the human subjects are not familiar with the driving simulator prior to testing, they can switch from real driving to simulated driving with ease and efficiency.
- iii) The control task should pose an important challenge to the human controller. In other words, the experiments can challenge individuals to drive near the edge of their abilities. Consequently, this will allow the variations in control strategy across different individuals.

The Car Driving Simulator is specifically designed for the lowest skilled person by taking into account the subjects without any experiences in driving or gaming. Hence, this designed simulator is suitable for all drivers. Moreover, this simulator is mainly used to collect the data from human subjects when they follow the displayed tracks on the computer screen. Figure 3.7 shows the graphical user interface of the program. Also, the simulated car is design to turn along the x -axis and move straight along the z -axis. However, the simulated car is unable to move up and down. In other words, y -axis is not use

for movement. In simulator, the green line acts as guided in following the track. In fact, the tracking error is measured based on how close the red crosshair (in the middle of simulated car) to the green line. Although the track width and dimension are existed in simulator, they have no effect to the error measurement, as well as the vehicle size. They only needed to show the simulated car in the left side of the road/track as happened in the real driving. Furthermore, the negotiations of corners are also made based on real road environments, consists of turning left or right, roundabout, sharp corner etc.

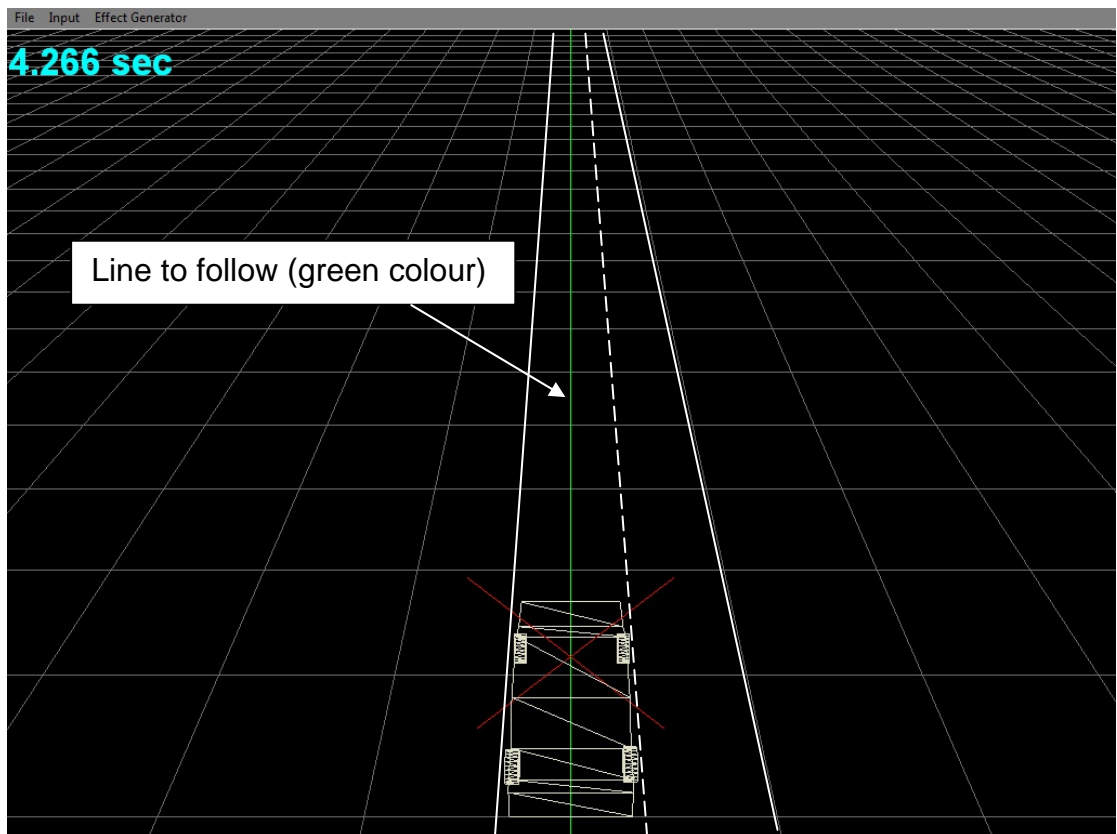

Figure 3.7: The designed driving simulator program gives the user a perspective preview of the road ahead and the green line as guidance. The user has independent control of the steering, brake and accelerator.

Special features of designed driving simulator are described below:

- a) Full screen display.
- b) On screen timing.
- c) 1 unit in MapMaker = 10 units in Car Driving Simulator.
- d) Full vibration feedback.
- e) Effect generator built in.
- f) Option for EGC and STC.
- g) The driving simulator is implemented with an automatic transmission.
- h) Top speed is achieved if the accelerator pedal is pressed gradually for a certain period of time. Similarly, if the accelerator is released, the simulation vehicle will gradually decelerate until it comes to a complete stop.

The simulation can be said to be realistic to real driving as follows:

- a. The simulated car has acceleration, $a = 1$ unit/sec and increased linearly until it reach maximum $a = 20$ unit/sec.
- b. The simulated car also has the deceleration, $a = -1$ to -20 unit/sec.
- c. The top speed of 600 unit/sec can be reached by pressing the accelerator pedal continuously.
- d. The simulation uses the analogue movement of steering and not the digital movement like a keyboard.
- e. The simulation also uses the similar hardware that included in real vehicles, such as steering and pedals.
- f. The vehicle dynamic used in simulation includes the kinematics and not the kinetics. In other words, the vehicle's weight, forces and road friction

are neglected. However, the control feedbacks of steering during slippery and tyre punctured are included. These conditions are measured using the feedback changes and forces to the steering wheel.

Figure 3.8 shows the schematic diagram of the physical system for Car Driving Simulator. The simulator has two inputs, which are steering wheel and pedals. Both inputs and simulator (PC) are connected through USB connection. The feedback signals from simulator are sending back to the steering and pedals using the same connection. The simulator also displays the movement of input and output through monitor.

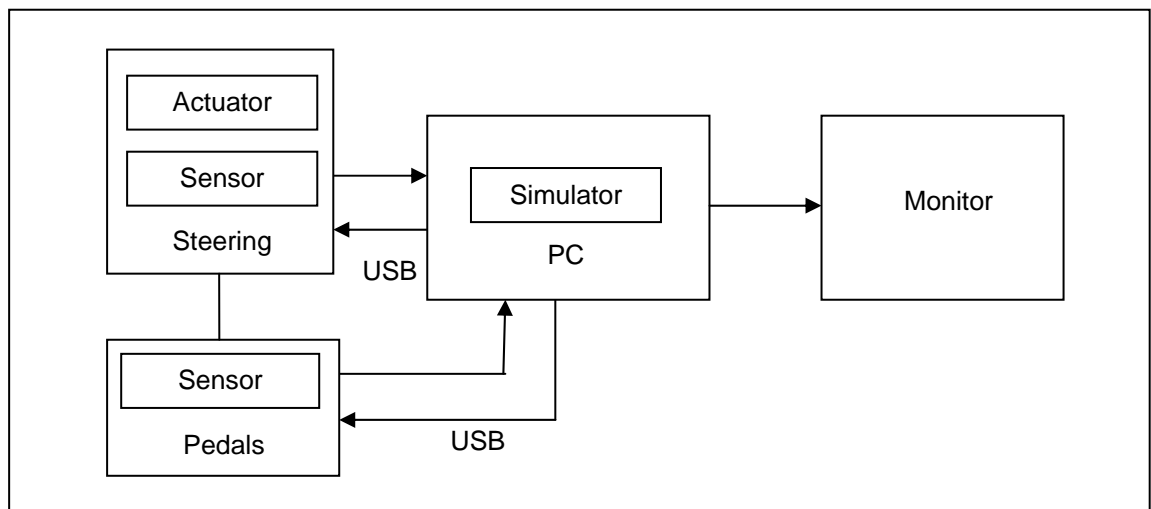

Figure 3.8: A schematic diagram of the physical system.

Figure 3.9 describes a flow diagram for the control system in Car Driving Simulator. This simulator is developed to relate the human and the machine closely, by completing a specific task. All the human actions are traced and can be measured using the simulator. Furthermore, it can be shown that there are three inputs through simulator, which are Steering, $s(t)$, Acceleration, $a(t)$

and Deceleration, $d(t)$. The velocity of the simulated car depends on the $a(t)$, $s(t)$ or $d(t)$ and noise, $n(t)$. Examples noise used are slippery and tyre puncture. On the other hand, there are two outputs from simulator, which are force feedback and visual feedback. Output from simulator also used for error measurement by comparing with reference track. Then, this error is used together with the elapsed time to quantify the skill of subject in other separate program. The programming source code is included in Appendix 5.

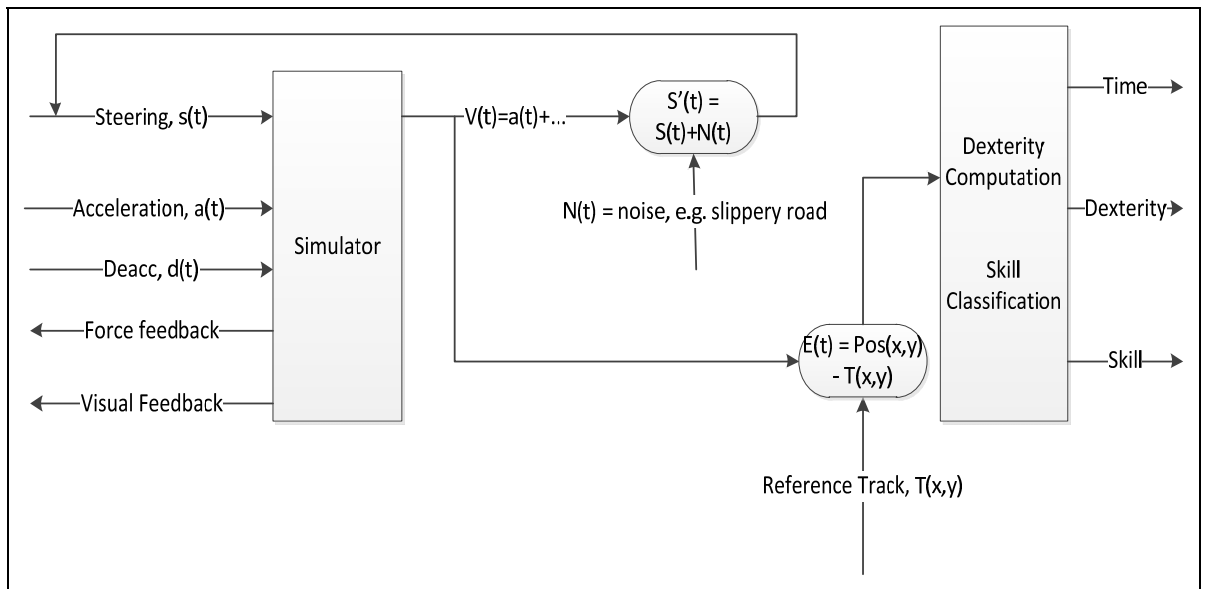

Figure 3.9: A flow diagram for the control system.

3.4.3 ERROR COMPUTATION PROGRAM

The third program is known as the Error Computation. This simple program is designed to calculate the tracking errors of all the subjects. The algorithm of this program is based on the error measurement method that explained in Section 3.5. Figure 3.10 shows the GUI and features of the program.

Features of the program are as follows:

1. There is illustration to show the track and path comparison in aforementioned colours.
2. There is 'zoom in' and 'zoom out' functions in program to close up any part of desired track/path.
3. There is also scroll of axes function to find the specific point on track/path.



Figure 3.10: Error computation program.

3.5 ERROR MEASUREMENT METHOD

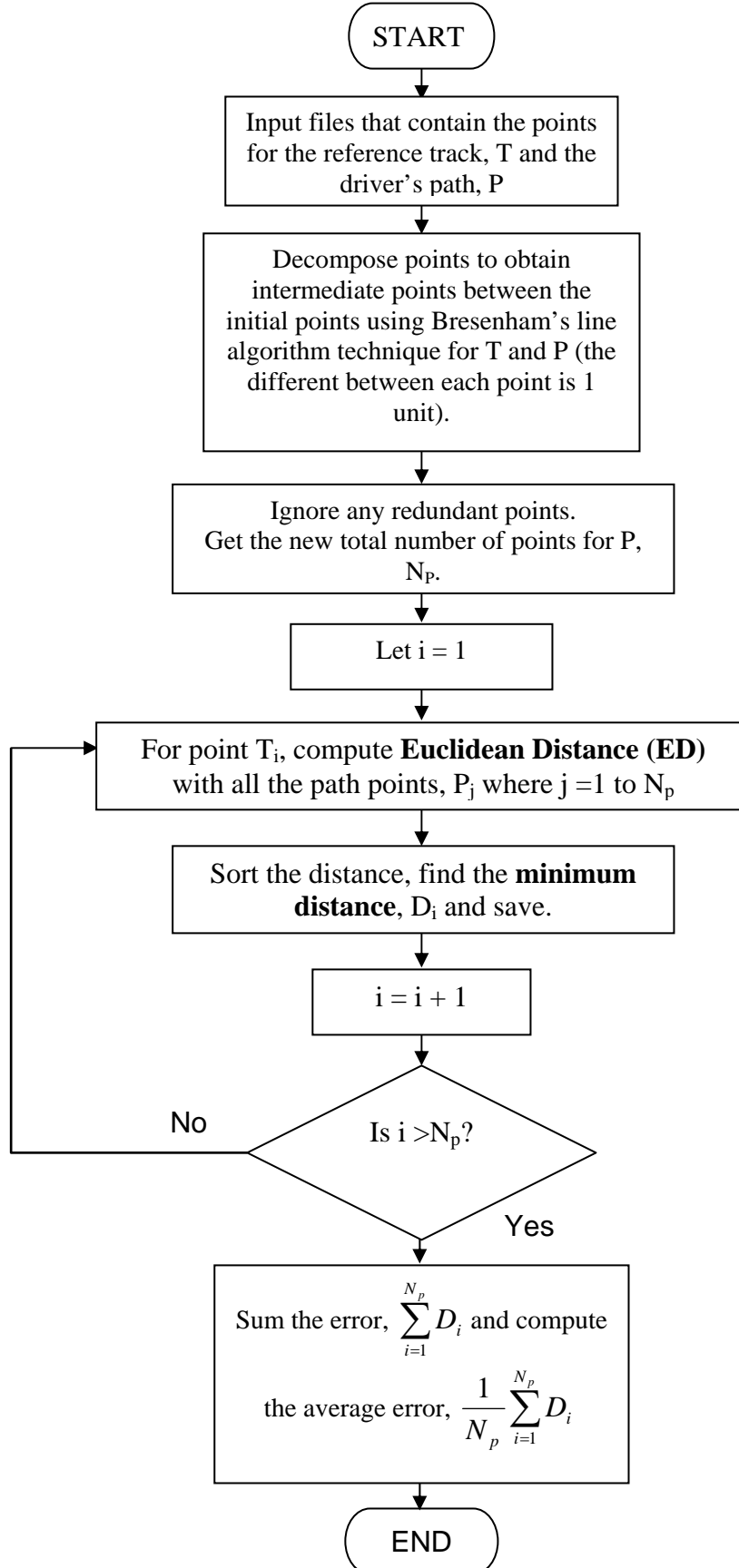

Figure 3.11: Flowchart of error measurement.

Figure 3.11 shows the flowchart of the error measurement that used in Error Computation program. This technique, developed by the author, represents a technical contribution in comparing the data from two different programs, which have different resolution.

In order to calculate the error, two files are needed which are the text files of the created track, T and the path of human subject, P. Normally, the total number of data points in P is more than the total number of data points in T, for example 100 points in T and 2000 points in P. It happens because T is created in Mapmaker program, whereas P is obtained from the Car Driving Simulator. Both of the programs have different resolutions that yield different total numbers of data points produced. Therefore, in order to measure the error, the data points of T and P need to be decomposed using an interpolation technique.

In the program code, Bresenham's line algorithm is selected as the interpolation technique. The Bresenham line algorithm is an algorithm which determines which points in an n-dimensional raster should be plotted in order to form a close approximation to a straight line between two given points (Bresenham, 1965). The selection of the algorithm is based on the speed and the simplicity of the algorithm.

By decomposing, it creates new data points between the initial points and the total number of data points in T and P will be increased. The example of T data is shown in Figure 3.4 in Section 3.4.1. Note that the coordinate of x and z are saved without a decimal point, means that all data points are integers.

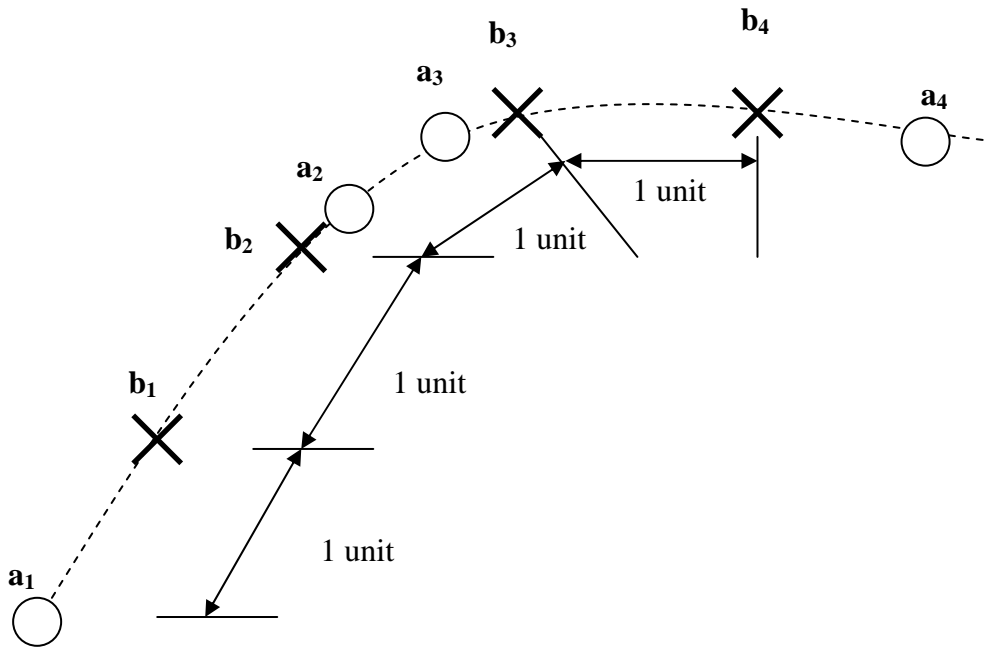

Figure 3.12: The initial points, **a** and the created points, **b**.

By referring to Figure 3.12, consider **a**₁, **a**₂, **a**₃ and **a**₄ as the initial points that obtained from Mapmaker or Car Driving Simulator program. By using Bresenham's line algorithm technique, **b**₁, **b**₂, **b**₃ and **b**₄ are created in order to maintain the 1 unit length among the points. The selection of 1 unit is based on the smallest possible length that can be measured between each coordinate. Then, any redundant points will be ignored. For example, in Figure 3.10, between point **b**₂ and **b**₃, there are point **a**₂ and **a**₃. The distance between point **b**₂ and **b**₃ is already 1 unit, so point **a**₂ and **a**₃ will be eliminated. After the elimination process, the new total number of data points in T and P will be obtained. But, the new total number of data points in P is more significant in calculating the error because it will be used as a loop counter in programming.

During the error measurement process, each T point will be compared to every P point, where the Euclidean distance is measured between these points using equation (3.1).

Euclidean distance,

$$\mathbf{ED} = \sqrt{(X_T - X_P)^2 + (Z_T - Z_P)^2} \quad (3.1)$$

where

X_T = coordinate x for track

X_P = coordinate x for path

Z_T = coordinate z for track

Z_P = coordinate z for path

Every T point will have the Euclidean distance for every P point, and these distances will be sorted to find the minimum distance, **D**. Note that the **ED** is also the **D** with the minimum value. In other words, each T point will have one minimum distance among the P points. These minimum distances will be saved and used in calculating the error. In this case, the error is the average minimum distance between T and P. This process will be repeated until it reaches the last point of T.

After that, the entire minimum distances will be summed and the average error will be measured between T and P. Therefore, in order to measure the error easily, the Error Computation program is developed as explained in Section 3.4.3. The user only needs to open the files that contain the track and the path. Then, the rest of the calculation process will be done by the program.

3.6 EXPERIMENTAL WORK

There are two experiments are carried out to accomplish the research objectives. Both experiments are using a computer simulation and a number of human subjects. Brief description of each experiment is described below:

3.6.1 DRIVING DURING EXPECTED AND GUIDED CONDITIONS

The main aim of this experiment is to understand the human control action in following the expected and guided tracks. There are five predefined tracks and 20 human subjects used. They requested to follow the track as accurate as possible. The tracking error and the elapsed time are recorded. The details of this experiment are explained in Chapter 5.

3.6.2 DRIVING DURING SUDDEN TRANSITORY CONDITIONS

The main aim of this experiment is to understand the human control action in following the unexpected and unguided tracks with disturbances. There are two types of disturbance or effect. The details of this experiment are explained in Chapter 6.

3.7 EXPERIMENTAL SETUP

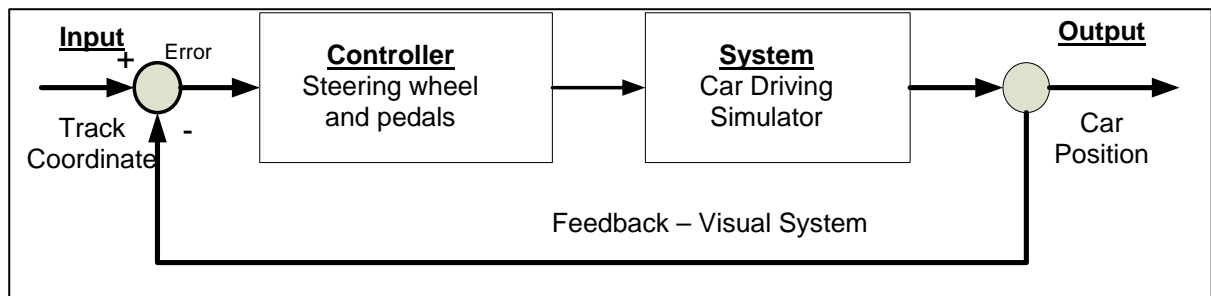

Figure 3.13: Block diagram of the experimental work.

The block diagram of all experiments is shown in Figure 3.13. According to the Figure 3.13, it appears that the control system used is a closed loop system with feedback, by considering that the human as part of system. The input is a track coordinate and the output is a car position. Therefore, in order to make the task achievable, a track and a car are shown in three dimensions (3D) simulation, so that the human subjects have a perspective preview of the road ahead, as shown in Figure 3.7.

Moreover, the system for experiments is a car driving simulator and the controller is a keyboard or a steering wheel with pedals. The feedback is a visual system from the human subject itself, which has an important role in reacting and correcting the position of the car through the specific tracks. In other words, it totally depends to human visual system in order to make sure the simulated car is following the track accurately.

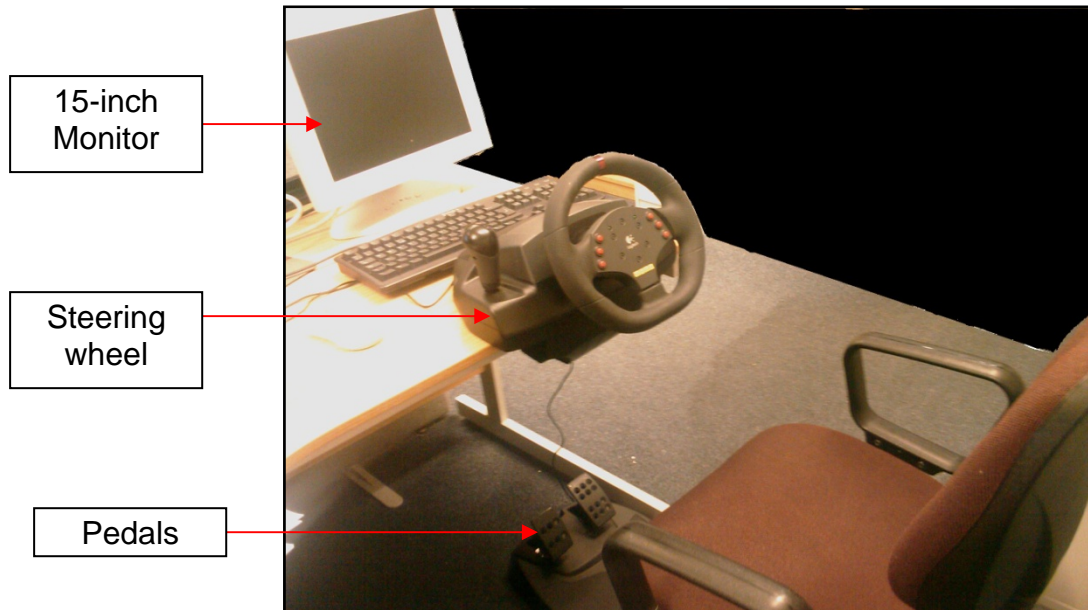

Figure 3.14: Experimental setup and hardware used.

The hardware setup in this study is shown in Figure 3.14. The steering wheel is attached to a desk using its triple clamping system in order to avoid rocking or slipping. The pedals are located in a way that the system imitates the real car driving environment. In addition, these pedals have their own carpet grip system to avoid slipping during the experiment.

3.8 HARDWARE USED

There are four main equipments used in this initial study in order to obtain the results. This section will explain each of the equipment in detail.

3.8.1 MONITOR

In the experiment, a 15-inch monitor with screen resolution of 1024 by 768 pixels is used. The monitor can be seen in Figure 3.14. Moreover, in order to get the best display, the highest colour quality which is 32-bit, was also used.

3.8.2 PC DESKTOP

The experimental work of this thesis mainly involves the use of computer simulator. Therefore, the minimum specifications of PC desktop used are shown in Table 3.1. These specifications are suitable to run the Visual Studio software smoothly. However, the higher specifications are recommended for further study.

Table 3.1: PC specifications.

CPU	Intel Pentium 3.00GHz
Operating System	Microsoft Windows XP Pro SP3
Memory	512 MB of RAM
Graphic Card	NVIDIA Quadro NVS with AGP8X
DirectX	Version 9.0
Hardisk Drive Capacity	120 GB

3.8.3 STEERING WHEEL AND PEDALS

The steering wheel and pedals used in the experiment is shown in Figure 3.135 which is the MOMO Racing Force Feedback Wheel. This hardware is commercialized by Logitech Company.



(a)



(b)

Figure 3.15: (a) Logitech MOMO Steering wheel (b) Foot Pedals

The selection of this hardware is based on the following features:

- i) USB connection that compatible with Windows XP.
- ii) Six programmable buttons to take command of favourite moves.
- iii) Gas and brake pedals with carpet-grip foot pedals.
- iv) Shifting options to choose whether paddle shifter or manual knob.
- v) Force feedback wheel technology.
- vi) Full rubber wheel to keep the hands comfortable with 11-inch wheel.
- vii) Triple clamping system to avoid rocking or slipping on a desk.

In the experiment, the following commands are used:

- i) **Accelerate:** press the accelerator pedal.
- ii) **Turn left:** press the accelerator pedal and rotate the steering wheel in anti-clockwise direction.
- iii) **Turn right:** press the accelerator pedal and rotate the steering wheel in clockwise direction.
- iv) **Brake or Stop:** press the brake pedal.

3.9 TRACKS CREATED

From MapMaker, there are five track patterns created and used in the experiments. All tracks are shown from top view in MapMaker and consist of straight, circular, elliptical, square and triangular patterns. All tracks are designed to imitate the actual road tracks.

3.9.1 STRAIGHT

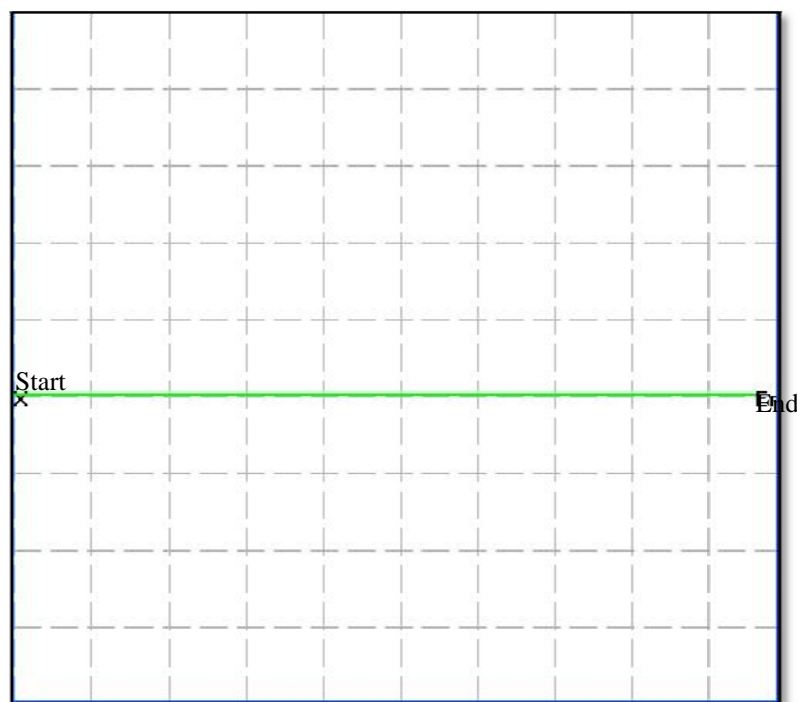

Figure 3.16: Straight track.

Figure 3.16 shows the straight track from top view. The features of this track are explained below:

- a) This track consists of 10 blocks in MapMaker.
- b) Length of track in Car Driving Simulator = 5000 units.
- c) Skill to negotiate: Skill to follow linear and continuous line.

3.9.2 CIRCULAR

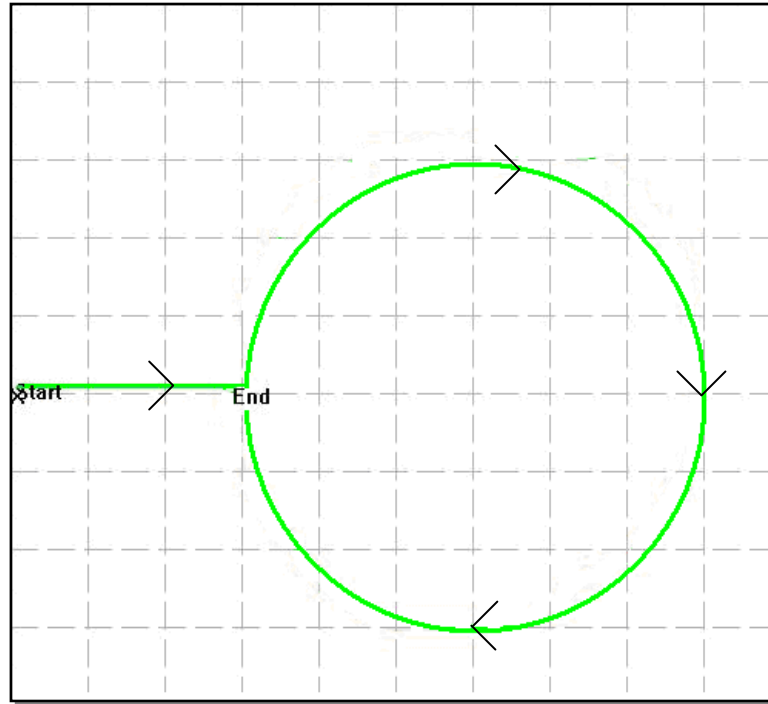

Figure 3.17: Circular track.

The circular track and its flow are shown in Figure 3.17. This track has the following features:

- a) The first three blocks (in MapMaker) is straight line.
- b) The first corner is left.
- c) The driving flow of track is clockwise.
- d) The diameter of circle is 3000 units (in Car Driving Simulator).
- e) The best mathematical equation represents the track is shown in equation (4.1).

$$(X - 250^2)(Z - 300^2) = 150^2 \quad (4.1)$$

- f) Length of track in Car Driving Simulator = 9500 units.
- g) Skill to negotiate: Skill to follow nonlinear line and continuous turning.

3.9.3 ELLIPTICAL

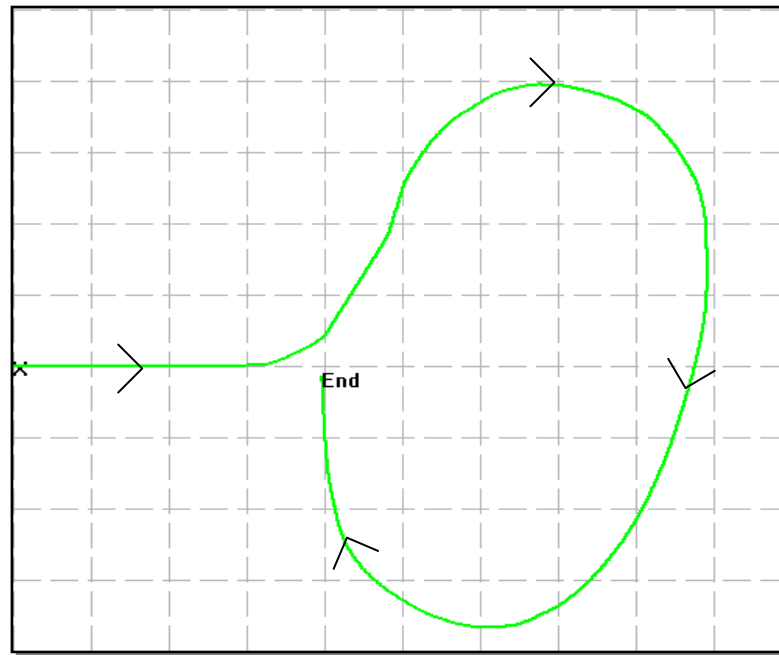

Figure 3.18: Elliptical track.

Figure 3.18 illustrates the elliptical track from top view. The track has the following features:

- The first three blocks (in MapMaker) is straight line.
- The first corner is left.
- The driving flow of track is clockwise.
- The length of track in Car Driving Simulator = 11000 units.
- The best possible mathematical equation for this track is shown in equation (4.2)

$$\frac{(X - 250)^2}{175^2} + \frac{(Z - 625)^2}{125^2} = 1 \quad (4.2)$$

- Skill to negotiate: Skill to follow other type of nonlinear line and continuous turning.

3.9.4 SQUARE

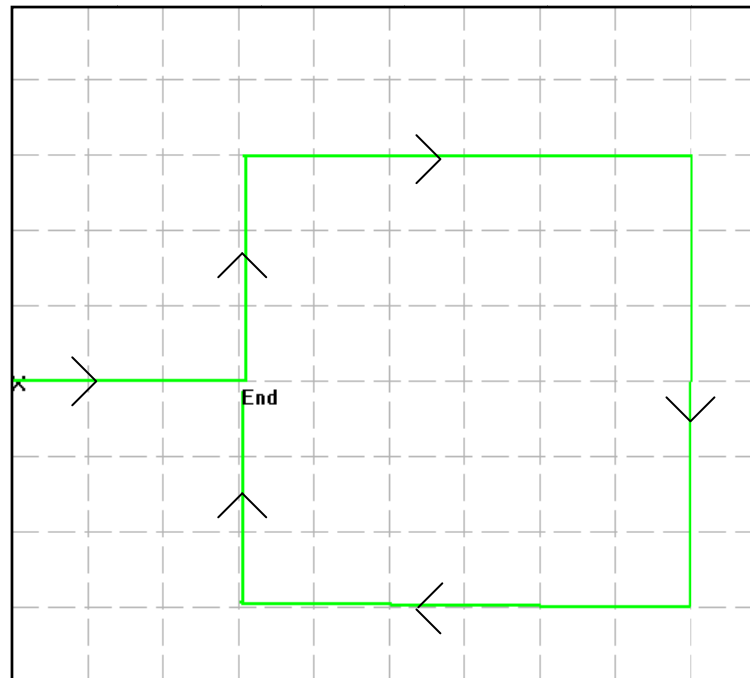

Figure 3.19: Square track.

The square track pattern and its flow are shown in Figure 3.19. This track has the following features:

- a) The first three blocks (in MapMaker) is straight line.
- b) There are five 90° corners.
- c) The first corner is left.
- d) The other four corners are right.
- e) Length of track in Car Driving Simulator = 13500 units.
- f) Skill to negotiate: Skill to follow linear line and 90° turn.

3.9.5 TRIANGULAR

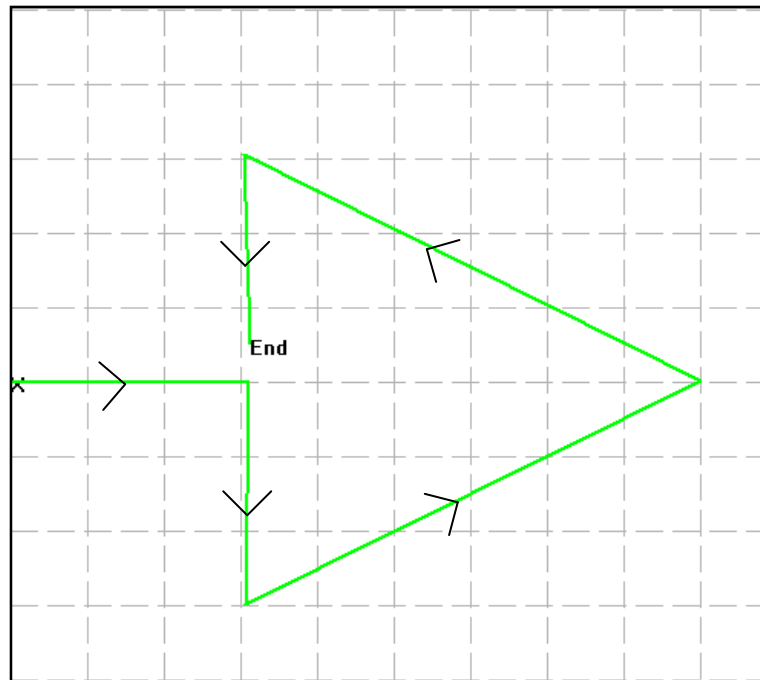

Figure 3.20: Triangular track.

The triangle track and its flow are shown in Figure 3.20. This track has the following features:

- a) The first three blocks (in MapMaker) is straight line.
- b) There are four corners.
- c) First corner is 90° turn to right.
- d) The other three corners are 60° turn to left.
- e) Length of track in Car Driving Simulator = 10000 units.
- f) The track flow is different compared to other tracks.
- g) Skill to negotiate: Skill to follow linear line and 60° turn.

The sharp corners are not fully representative of a real road situation and it was not possible for drivers to follow the sharp corners exactly. However, the tests are comparative and the conditions were the same for all drivers.

3.10 HUMAN SUBJECTS' FEATURES

Table 3.2 Human subjects' experience in driving and gaming and their age.

Subject	Year(s) of experience		Age
	Driving	Gaming	
A	10	1	30
B	2	1	29
C	0	0	30
D	23	0	43
E	6	8	26
F	20	0	40
G	10	5	30
H	7	0	30
I	9	6	29
J	15	3	32
K	6	1	29
L	10	0	36
M	13	4	33
N	8	2	30
O	12	4	30
P	15	0	35
Q	6	3	29
R	3	0	30
S	16	3	36
T	10	5	29
AVERAGE	10.05	2.30	31.8

Apart from gender neutral, the human subjects are divided into three categories which are the number of years of experience in driving and the number of years of experience in gaming, and their age. Experience in gaming is included because the experimental work mainly used the computer

simulator. Table 3.2 shows the number of years of both experiences for all human subjects and their age.

The driving experience is related to real car control in the real world, whereas the gaming experience is related to the race type games such as Need for Speed, Formula 1 and Drift. Based on Table 3.2, Subject D has the highest number of experience in driving, which is 23 years. However, he has no experience in gaming. On the other hand, Subject E has the highest number of experience in gaming, which is 8 years. However, he only has 6 years experience in driving. Apart from that, Subject C has no experience in either both categories. In total, the average experience in driving for all subjects is about 10 years. On the other hand, the average experience in gaming is two years. Furthermore, the average age for subject is about 32 years old.

3.11 SUMMARY

In this chapter, the methodology in conducting this research is presented. All the steps are explained in detail. The methods of data collection are described which consists of two main experiments. Due to fact that the experiments mainly involved the computer simulation, the factors that affected the choice of software are also presented. Three designed programs are also explained in order to achieve the objectives of thesis. Moreover, the new error measurement technique is explained in greater detail. The experimental setup, the hardware, and the tracks' patterns are also described, as well as the human subjects' features.

CHAPTER 4

PROPOSED SKILL INDEX FORMULA

4.1 INTRODUCTION

In this chapter, the proposed skill index formula is discussed with details of formula development. The skill index, J is used to measure the human performance in terms of normalized time and error. Formulas to normalize time and error are also presented with a few assumptions made. Then, the development of the proposed formula is discussed. The classification of J into five levels is also shown. Other techniques such as the Fuzzy Logic System and the formula from Sasaki *et al.* (2007) are explained at the end of this chapter.

4.2 NORMALIZATION – IN GENERAL

Normalization is defined as the process of transforming any value into a specific range. The value of data might be too small or too big that yields difficulties to analyse. In this thesis, in order to maintain the value zero as the fastest for time or the smallest for error and value one as the slowest for time or the largest for error, the general formula in normalizing the raw data is shown in Equation (4.1).

$$\text{Normalized X, } X_n = \frac{x - X_{\min}}{x} = 1 - \frac{X_{\min}}{x} \quad (4.1)$$

where

x is a real value or score,

X_{\min} is a minimum score and $x \geq X_{\min}$

If $x \rightarrow X_{\min}$, then $X_n \rightarrow 0$

If $x \rightarrow \infty$, then $X_n \rightarrow 1$

4.3 NORMALIZED TIME

In any experiment and system, if the actual execution time is used, the range of time is between zero and infinity. This brings difficulties in measuring the skill of the human operator due to the large range. Therefore, the normalized time is used so that the range is only between zero and one. The formula to normalize time is shown in equation (4.2). In reality, the value can never reach one.

$$T_n = 1 - \frac{T_B}{t} \quad (4.2)$$

where

T_B = the best theoretical time by assuming the track is a straight line; ignoring the corners and braking; and using the maximum speed during operation.

t = time elapsed by each subject.

Based on equation (4.2), a human subject can obtain zero in normalized time if $t = T_B$, which is the fastest time. In other words, if he/she is very fast to complete any track, then $T_n \rightarrow 0$. Similarly, he/she can obtain one in T_n when the time is the slowest ($t \rightarrow \infty$).

4.3.1 THE BEST TIME, T_B

As explained above, the best time is the ideal elapsed time to complete any track based on maximum speed used and is obtained by using the following formula:

$$T_B = \frac{L}{V_{\max}} \quad (4.3)$$

where

L = length of track in driving simulator (units).

V_{\max} = maximum speed in driving simulator, which is 600 unit/second.

Table 4.1 shows the best time of each track. The square track is the longest track in the driving simulator, consisting of 13500 units. Therefore, this track needs 22.5 seconds to complete. On the other hand, the straight track is only 5000 units in length and needs 8.3 seconds to complete.

Table 4.1: The best time of each track in the driving simulator.

Track	Length, L (units)	Best time, T_B (seconds)
Straight	5000	8.3
Circular	9500	15.8
Elliptical	11000	18.3
Square	13500	22.5
Triangular	10000	16.7

4.4 NORMALIZED ERROR

The range for actual errors obtained by human subjects is also between zero and infinity. Therefore, an error is normalized using equation (4.4) to keep the range between zero and one.

$$E_n = 1 - \frac{E_s}{e} \quad (4.4)$$

where

E_s = the smallest possible error determined using specific rules where $E_s < e$.

e = actual error obtained by each subject.

Based on equation (4.4), if a human subject commits a very small error, which is near to E_s , and then E_n is near to zero. Nevertheless, for a larger error which is e near to ∞ , then E_n is near to one.

4.4.1 THE SMALLEST POSSIBLE ERROR, E_s

The smallest possible error is obtained from experiment and subject-dependence. It means that the value of E_s is totally depends on the smallest error obtained from one of the subjects in any trial of experiment. In other words, this value is only valid for sampled human subjects and does not represent the whole human population.

Considering $X.YZ$ is the smallest error obtained by a human subject in track A, then the value of E_s is determined using the following rules:

- 1) If the value of $Z \leq 5$, then $E_s = X.Y0$,
- 2) If the value of $Z > 5$, then $E_s = X.Y5$.

By using these rules, the value of E_s always becomes less than e . For example, the smallest error in circle track is 1.61, obtained by Subject A in the fourth trial then E_s is determined as 1.60 and this value will be used in the total calculation of normalized error for all human subjects of this track. Similarly, if the smallest error in square track is 1.59, then E_s becomes 1.55.

4.5 FORMULA DEVELOPMENT

Table 4.2: Combination of E_n and T_n for each skill index, J .

E_n	T_n	J
S	F	VHS
S	M	HS
S	Sl	MS
M	F	HS
M	M	MS
M	Sl	LS
L	F	MS
L	M	LS
L	Sl	VLS

Legend:

S – Small, M – Medium, L – Large, F – Fast, Sl – Slow, VHS – Very Highly Skilled, HS – Highly Skilled, MS – Medium Skilled, LS – Low Skilled, VLS – Very Low Skilled.

The proposed formula is based on Table 4.2, which is evaluated using the logical conditions and the definition of skill in HAM, as explained in Chapter 2. This table was conceived and developed by the author, together with Equation 4.5. It is based on the principle of a ‘Truth Table’ as used in Digital Electronics. For example, if a human operator executed a task in a fast time ($F = \text{Fast}$) with a small error ($S =$

Small), then the skill index, J of the human operator is rated as Very Highly Skilled (VHS). Similarly, if the execution time is medium (M), and the error is large (L), then the skill index, J is given as Low Skilled (LS).

In developing the formula, every term of error and time on Table 4.2 has been replaced with an equivalent value, such as Small (S) = Fast (F) = 0, Medium (M) = 0.5, Large (L) = Slow (Sl) = 1. Similarly, the terms of J are also replaced with the equivalent values, i.e. VHS = 1.00, HS = 0.75, MS = 0.50, LS = 0.25 and VLS = 0.00. These values are determined between zero and one that are divided into eight segments as shown in Figure 4.1. The values in the box are selected for each J term, so that the range is 0.25 between each selected value. Hence, Table 4.3 shows the complete equivalent values used for each combination of T_n , E_n and J .

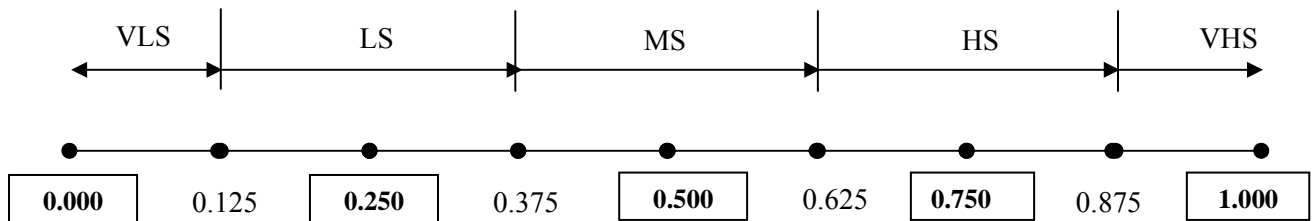

Figure 4.1: The way to select a value and range for each skill level.

Based on Table 4.3, the formula to quantify the skill is developed as follows. Let say the linear relationship between J and (T_n, E_n) is shown in equation (4.5).

$$J = AT_n + BE_n + C \quad (4.5)$$

where $A, B, C = \text{constants}$.

To solve equation (4.5), values of E_n , T_n and J from Table 4.3 are used as follows:

Table 4.3: The equivalent values used for E_n , T_n and J .

E_n	T_n	J
0.00	0.00	1.00
0.00	0.50	0.75
0.00	1.00	0.50
0.50	0.00	0.75
0.50	0.50	0.50
0.50	1.00	0.25
1.00	0.00	0.50
1.00	0.50	0.25
1.00	1.00	0.00

4.5.1 VALUE C

By using $E_n = 0$, $T_n = 0$, and $J = 1$, then equation (4.5) becomes

$$1 = A(0) + B(0) + C$$

so that,

$$C = 1 \tag{4.5a}$$

4.5.2 VALUE A

By substituting equation (4.5a) into equation (4.5), then

$$J = AT_n + BE_n + 1 \quad (4.5b)$$

Then, by using $E_n = 1$, $T_n = 1$, $J = 0$, so

$$0 = A + B + 1$$

$$B = -(1 + A) \quad (4.5c)$$

By substituting equation (4.5c) into (4.5b), then

$$J = AT_n - (1 + A)E_n + 1$$

$$J = A(T_n - E_n) - E_n + 1 \quad (4.5d)$$

From Table 4.3, when $E_n = 0$, $T_n = 0.5$, then $J = 0.75$, equation (4.5d) becomes

$$0.75 = A(0.5 - 0) - 0 + 1$$

$$0.5A + 1 = 0.75$$

and simplify as

$$A = -0.5 \quad (4.5e)$$

4.5.3 VALUE B

The value of B can be measured by substituting equation (4.5e) into equation (4.5c).

Then,

$$B = -(1 + 0.5)$$

So that,

$$B = -0.5 \tag{4.5f}$$

4.5.4 FINAL FORMULA

Now, by substituting equations (4.5a), (4.5e) and (4.5f) into (4.5),

$$J = -0.5T_n - 0.5E_n + 1$$

or can be simplified as follows

$$J = 1 - 0.5(T_n + E_n) \tag{4.6}$$

The range of J , E_n and T_n are from 0 to 1.

4.6 CLASSIFICATION OF SKILL

As previously mentioned in Table 4.2, the proposed skill index is divided into five levels, which are VLS, LS, MS, HS and VHS. Also, the range for each level can be determined based on Figure 4.1. The best level is VHS, which ranges between 0.875 and 1. On the other hand, the worst level is VLS, which consists of 0 to 0.125. Table 4.4 shows the complete range of each skill level.

Table 4.4: Range for each level of J .

Skill Level	Range
VLS	$0.000 \leq J \leq 0.125$
LS	$0.125 < J \leq 0.375$
MS	$0.375 < J \leq 0.625$
HS	$0.625 < J \leq 0.875$
VHS	$0.875 < J \leq 1.000$

4.7 ALTERNATIVE FORMULAS

4.7.1 FUZZY LOGIC

The Fuzzy Logic System (FLS) can also be used to obtain the skill index, J . According to Zadeh (1973), FLS is easy to understand, flexible, based on natural language, tolerant of imprecise data, can model nonlinear function of arbitrary complexity, can be built on top of the experience of experts and can be blended with conventional control techniques. Therefore, the example of FLS method for quantifying the skill index is briefly explained as follows and is developed by using MATLAB.

The inputs for FLS are E_n and T_n ; and the output is J as shown in Figure 4.2. The Fuzzy Inference System (FIS) might use the most common method which is the

Mamdani-type inference. This type is intuitive, well suited to human input and has widespread acceptance (Mamdani and Assilian, 1975).

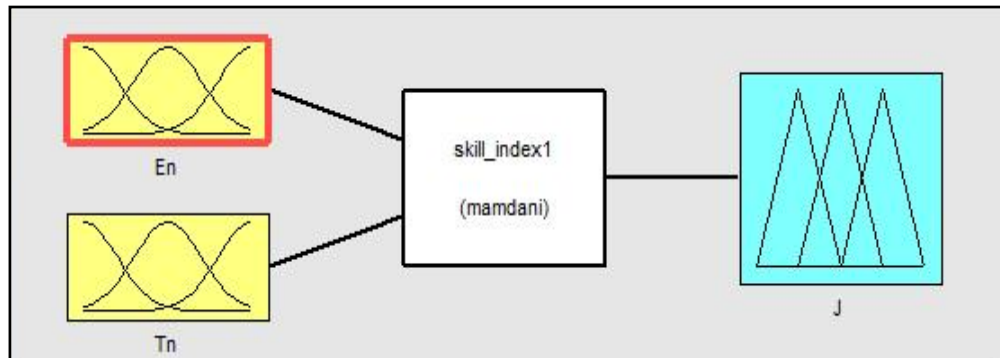

Figure 4.2: Inputs and output for Fuzzy Logic System.

First input, E_n has 3 membership functions, which is S – small, M – medium and L – large as shown in Figure 4.3.

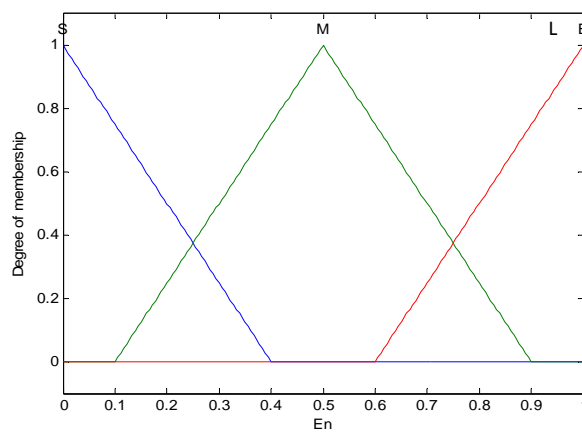

Figure 4.3: Membership functions for normalized error, E_n .

Second input, T_n also has 3 membership functions, which is F – fast, M – medium and SI – slow as shown in Figure 4.4.

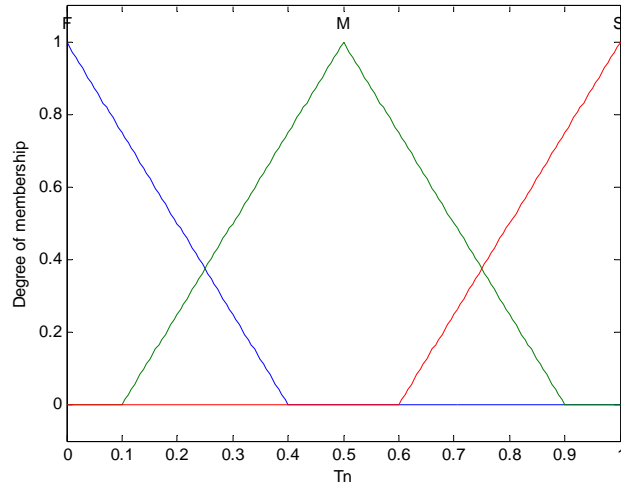

Figure 4.4: Membership functions for normalized time, T_n .

However, the skill index, J has 5 membership functions, which are VHS – very highly skilled, HS – highly skilled, MS – medium skilled, LS – low skilled and VLS – very low skilled as shown in Figure 4.5. Also from Figure 4.5, the range for each skill level is determined and is similar to the range for the proposed formula as shown in Table 4.4.

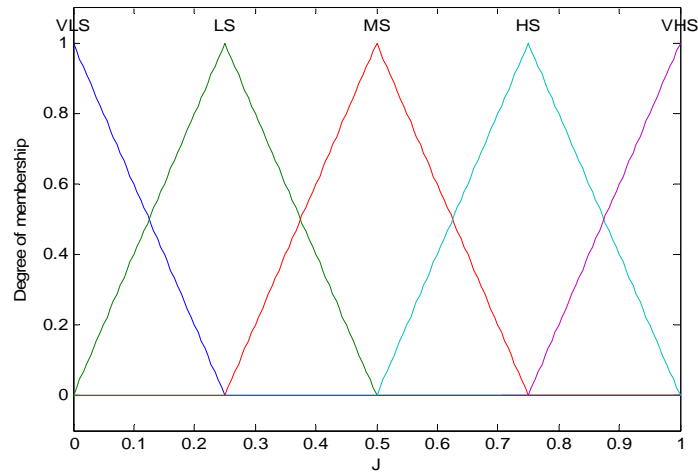

Figure 4.5: Membership functions for skill index, J .

The rules used in this Fuzzy Logic system are simplified in Table 4.5. These rules use the same considerations made for the proposed formula. Examples rule are:

- a. If normalized error is S and the normalized time is F, then the skill index is VHS.
- b. If normalized error is B and the normalized time is Sl, then the skill index is VLS.

Table 4.5: Rules for example Fuzzy Logic System.

E_n \ T_n	F	M	SI
S	VHS	HS	MS
M	HS	MS	LS
L	MS	LS	VLS

4.7.2 SASAKI'S FORMULA

Sasaki *et al.* (2007) also proposed a formula to quantify the skill by measuring the distance from a certain point in a normalized graph of time and error. They used point (1,0) for reference as shown in Figure 4.6. By measuring the distance from this point, they proposed the formula for skill index, J_s as

$$J_s = \sqrt{(1 - E_n)^2 + T_n^2} \quad (4.7)$$

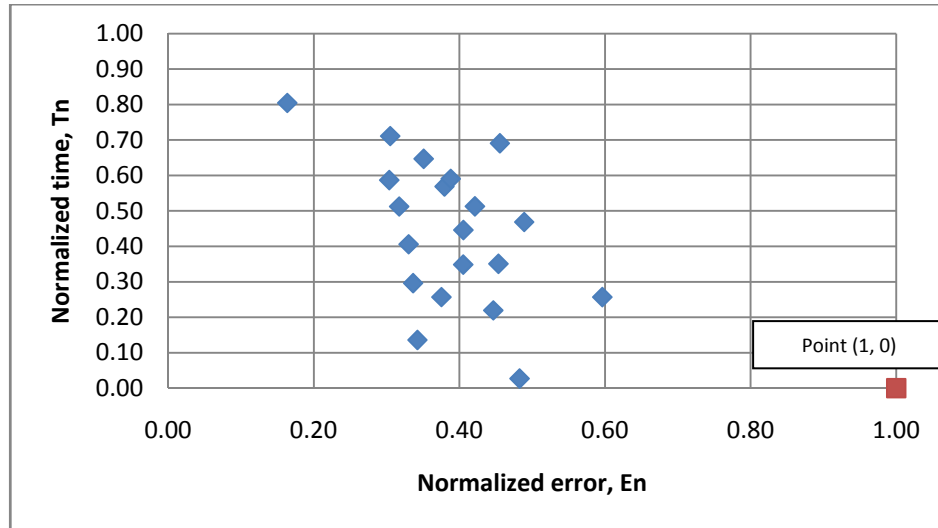
Figure 4.6: Normalized graph, T_n versus E_n

If the distance of normalized data (blue colours points from Figure 4.6) is near to the point (1, 0), then the skill index (J_s) is considered as high. Therefore, according to equation (4.7), the closest distance is zero unit when $E_n = 1$ and $T_n = 0$. In other words, based on Sasaki's formula, a human subject is considered highly skilled when he/she is the fastest with the largest error. On the other hand, if the distance of normalized data is far away from the point (1, 0), then the skill of human subject is becomes low. Based on equation (4.7), the furthest distance is $\sqrt{2}$ units when $E_n = 0$ and $T_n = 1$. It means that a human subject becomes low skilled when he/she is the slowest in time without any error. Therefore, equation (4.7) is proved to be wrong in order to quantify the skill index.

In terms of level, Sasaki *et al.* (2007) classified the skill index into only three categories, which is highly skilled (HS), middle skilled (MS) and low skilled (LS).

The range of each class is shown in Table 4.6. Again, this range does not seem to cover every value between 0 and $\sqrt{2}$.

Table 4.6: Skill level based on Sasaki *et al.* (2007).

Range	Class
$0.32 < J \leq 0.45$	High Skilled (HS)
$0.45 < J \leq 0.85$	Middle Skilled (MS)
$0.85 < J \leq 1.17$	Low Skilled (LS)

4.8 SUMMARY

The novel skill index formula has been presented in this chapter. The linear relationship between normalized time and normalized error is proposed in order to quantify the skill index. This chapter also shows the development of the formula with a few assumptions made in normalizing the time and error. Also, the method to determine the range of each skill level is presented. Lastly, other alternative formulas are explained, consists of Fuzzy Logic System and the Sasaki's formula.

CHAPTER 5

STUDY OF HUMAN SKILL IN EXPECTED AND GUIDED CONDITIONS (EGC)

5.1 INTRODUCTION

This chapter describes in detail the approach on the study of human driving skill in Expected and Guided Conditions (EGC). The term EGC refers to a normal driving situation that requires a driver to maintain direction on a predefined track without the addition of any external disturbance.

An experiment was conducted with the help of computer simulation software as a means of simulating the interaction between human subject and the machine; whereby the experiment was conducted on 20 human subjects with various years of experience in real-life driving scenarios and also experience in driving simulation games. Subjects were instructed to follow several predefined tracks as accurately as possible

in the shortest time by using a steering wheel with pedals – as described in Chapter 3. The aims, objectives and the fundamental hypotheses of the experiment are explained in the following sections.

5.2 OBJECTIVES OF EXPERIMENT

The main aim of this experiment is to understand the human control action in following the expected and guided tracks. ‘Expected’ means the tracks are in normal condition and shape; while ‘guided’ means that there are specific lines provided in each track as a driving path reference. In other words, the experiment is designed to differentiate human capabilities and characteristics in a normal human machine system by using a driving simulator. The simulator consists of human interface device and computer simulation software. According to Ertugrul (2007), driving is considered as a complex task because a human must possess specific skills such as the skill to handle the steering for direction, maintain the pedals for speed, and recognize various driving conditions such as cornering. Therefore, the objectives of this experiment are:

- a) To find the tracking error and elapsed time for five predefined tracks in normal conditions.
- b) To measure the skill index of each subject based on proposed linear equation.
- c) To identify the learning skill for each human subject based on five trials.

5.3 SCOPE OF EXPERIMENT

The experiment is designed to measure several main aspects of human-machine interaction. In this experiment, the input device used is a steering wheel with pedals. Standard input methods for computer based simulation such as keyboard, joystick or mouse were not considered. These standard input devices do not reflect the actual driving condition experienced in real-life. In order to mimic the actual driving condition, the steering wheel and pedals were chosen. A subject is able to change vehicle direction in the simulation through the steering wheel input, and accelerate or decelerate through the pedals.

The simulation is then conducted on five predefined tracks. The tracks are defined based on the route shape/direction. Each track is capable of measuring a different set of human dexterity. The tracks are (1) a straight track, (2) a circular track, (3) an elliptical route, (4) a square route and (5) a triangular route. More details on these tracks are discussed in Chapter 3.9. All tracks are designed to imitate the actual road tracks thus no complex arbitrary tracks were proposed. The summary of each track is discussed in Section 5.6.

The sequence of track is similar in entire experiment for every human subject. Section 5.6 describes the sequence in detail. This assumes that the order of track does not affect the results.

This experiment only involves visual ability from the human subject as a feedback mechanism, without any assistance from the machine. Any movement or action made by the human subject will directly affect the driving path and is important in determining the tracking error.

The driving simulator is implemented with an automatic transmission, which has a linear speed increment with a top speed of 600 units per second. Automatic transmission is suitable for all human subjects, and is not limited to experienced drivers. Top speed is achieved if the accelerator pedal is pressed gradually for a certain period of time. Similarly, if the accelerator is released, the simulation vehicle will gradually decelerate until it comes to a complete stop. The simulation vehicle will come to a complete stop if the accelerator is released continuously for 2 seconds without braking. This situation will help the subjects to make a decision whether to stop or continue the driving. This also allows the program to record the last movement before resetting the time.

Finally, in terms of gender, the experiment assumed that the human-machine interaction dexterity is gender neutral. Although in the experiment, the human subjects consisted of both male and female, it is assumed that the experiment outcome reflects human skill in general and is not biased towards any gender.

5.4 HYPOTHESES

Before conducting the experiment, the following hypotheses were outlined;

- H1 Tracking error is inversely proportional to elapsed time.
- H2 Elapsed time is expected to decrease after several trials.
- H3 Tracking error is also expected to decrease after several trials.
- H4 A higher tracking error is expected on a track with more bends and corners.
- H5 Human skill is expected to improve gradually after several trials.
- H6 It is expected that the human performance decreases gradually from very high (straight track), high (circular and elliptical tracks) and medium skill (square and triangle-shaped tracks).
- H7 Experienced drivers or experienced gamers are expected to have high skill.

Hypothesis H6 has been added at this stage to allow investigation of the effects of track complexity.

5.5 EXPERIMENT FEATURES

Table 5.1 Summary of tracks used in EGC.

Track	T_B (s)	Skills to negotiate	Expected skill (at least)
Straight	8.3	Skill to follow linear and continuous line.	HS
Circular	15.8	Skill to follow nonlinear line and continuous turning.	HS
Elliptical	18.3	Skill to follow other type of nonlinear line and continuous turning.	HS
Square	22.5	Skill to follow linear line and 90° turn.	MS
Triangular	16.7	Skill to follow linear line and 60° turn.	MS

Note: T_B is the best time.

Table 5.1 shows the features of each track used and the types of skill measured during the experiment. T_B is the best time as discussed in Chapter 4.2.1. The tracks without any corners are expected to give at least HS to any subject. Tracks with corners are expected to give at least MS to any subject, as the experiment is conducted in EGC mode.

5.6 EXPERIMENTAL PROCEDURE

Figure 5.1 shows the flowchart of the experimental procedure for each human subject. Before conducting the experiment, the human subjects are briefed on the experimental procedures. The subjects are given 30 seconds to test and get familiarised with the steering wheel and the pedals before start of the real trial. After the initial familiarisation period, the experiment is conducted in the following sequence:

1. Straight track.
2. Circular track.
3. Elliptical track,
4. Square track.
5. Triangular track.

The human subjects are requested to accurately follow the track as fast as possible without stopping until the end point. There are five trials for each track. For each trial, the elapsed time and the coordinates of the simulation car in x,z axes are recorded. By using these coordinates, the path of human subject is obtained and the tracking error is measured in a separate program.

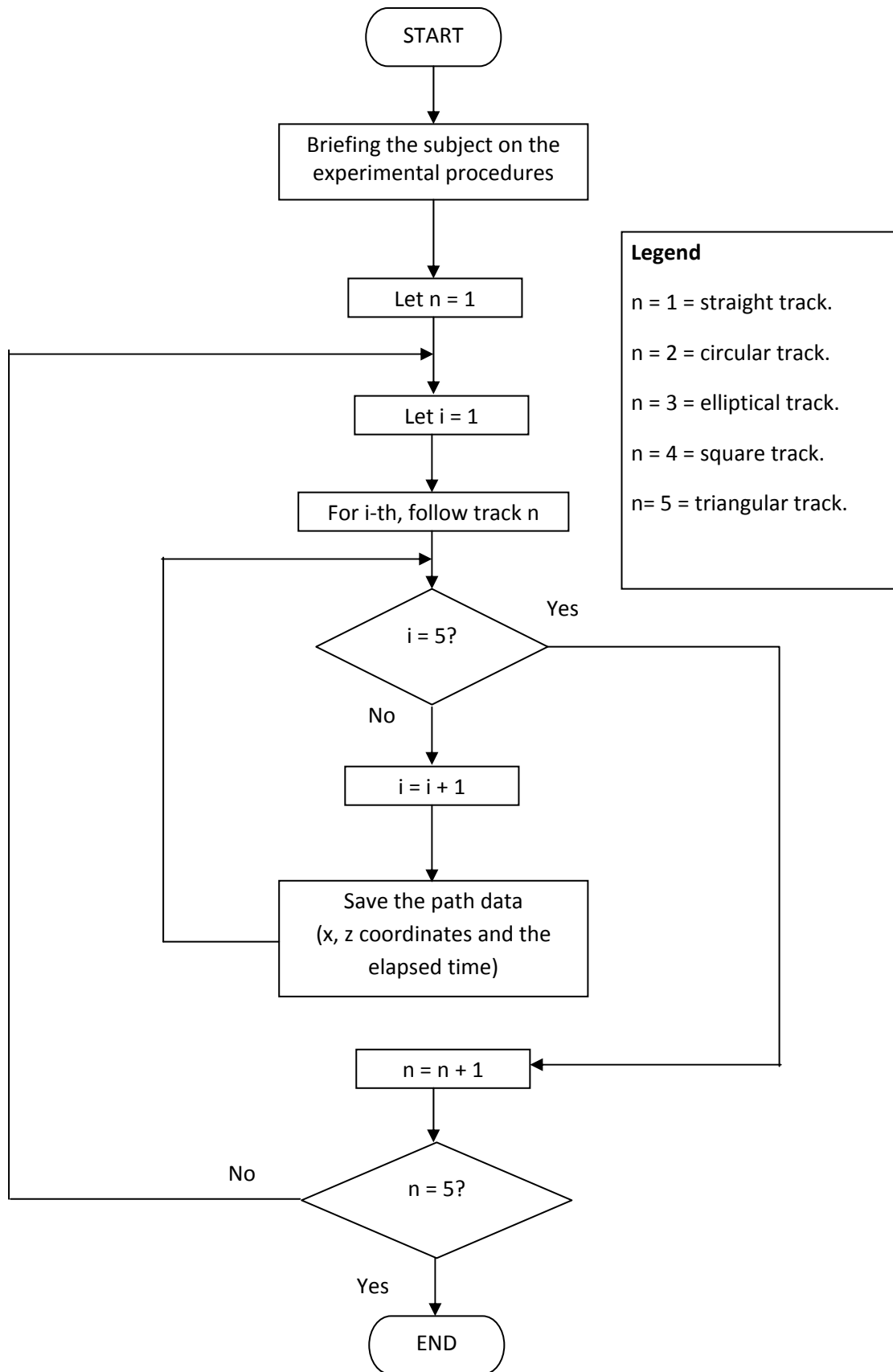

Figure 5.1: Flowchart of the experimental procedure.

5.7 RESULTS BY TRACK

This section shows the experimental results from 20 human subjects (Subject A to Subject T). Every human subject generated 50 data sets of elapsed time and tracking error obtained from five tracks. Therefore, for this experiment, a total of 1000 data sets were generated. Note that the line graph is for elapsed time and the column graph is for tracking error. Also, E1 is the tracking error in trial 1, E2 is the tracking error in trial 2, T1 is elapsed time for trial 1 and T2 is elapsed time in trial 2 and so on.

5.7.1 STRAIGHT TRACK

For straight track, Figure 5.2 shows the results of tracking error and elapsed time for each subject in every trial. For trial 1 (Figure 5.2(a)), Subject F is the slowest and Subject I is the fastest. However, the smallest error obtained by Subject G and the largest error obtained by Subject H. Thus, trial 1 does not support hypothesis H1. For trial 2 (Figure 5.2(b)), Subject C is the fastest and obtained the largest error. Thus, this result in trial 2 supports H1. However, the slowest (Subject F again) and the smallest error (Subject A) do not support H1.

Figure 5.2(c) shows the results of every subject in trial 3. It can be shown that, Subject F is the slowest for third consecutive time. However, for this trial, the slowest yields the smallest error. Thus, H1 is supported. Other results show that Subject E is the fastest and Subject I is obtained the largest error.

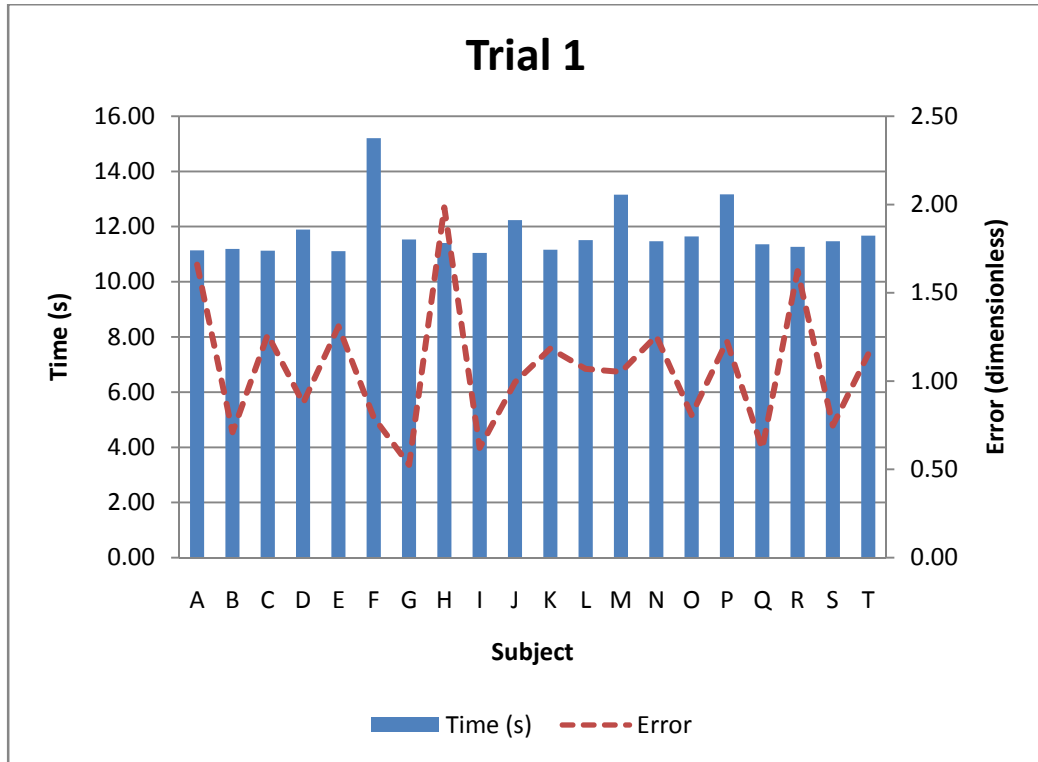

(a)

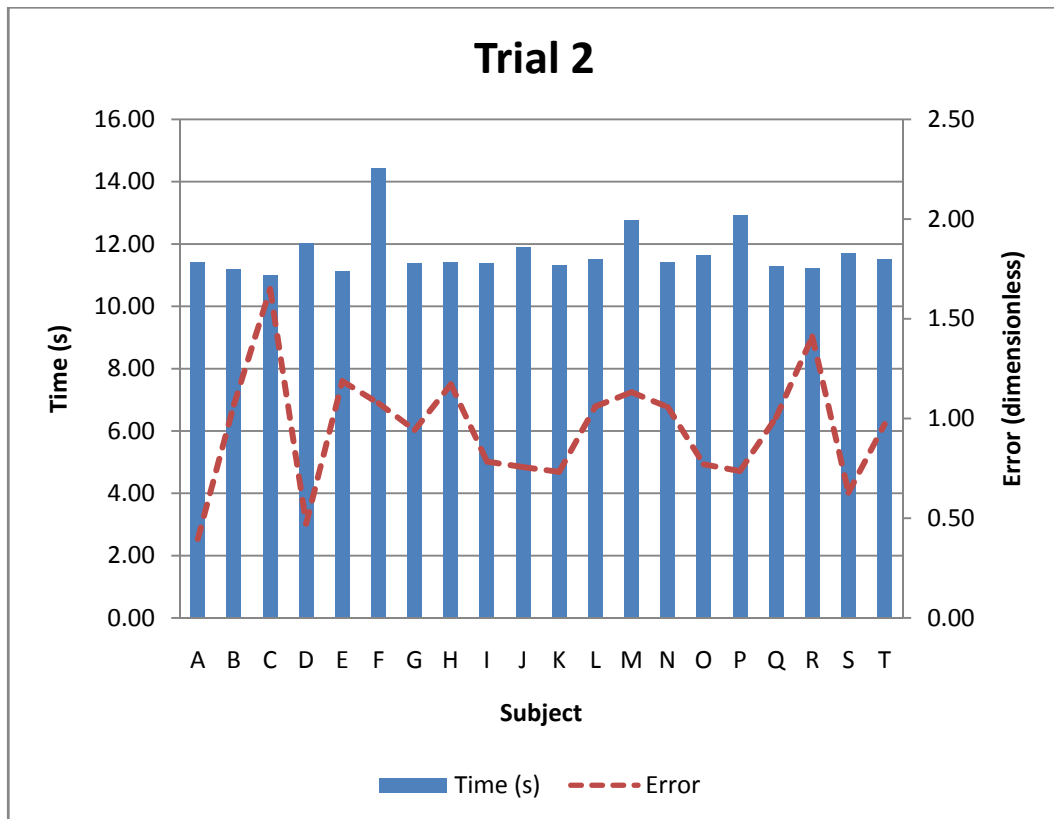

(b)

Figure 5.2: Results from straight track. Refer to Appendix 1(A) for detail.

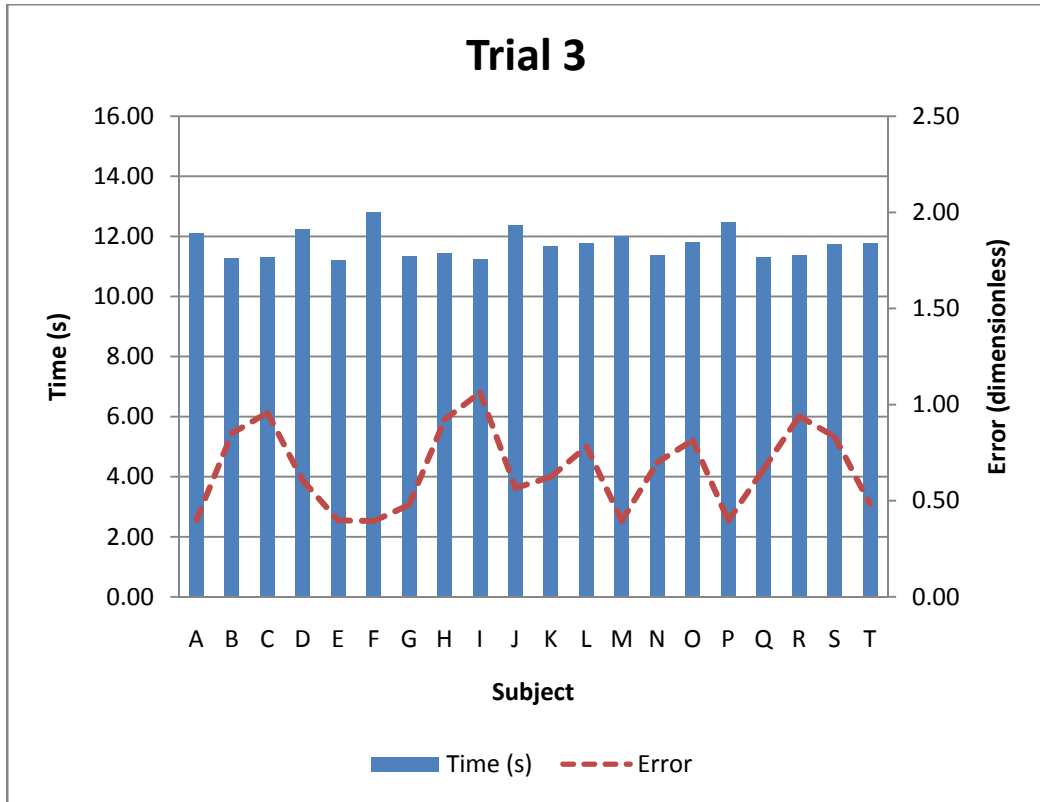

(c)

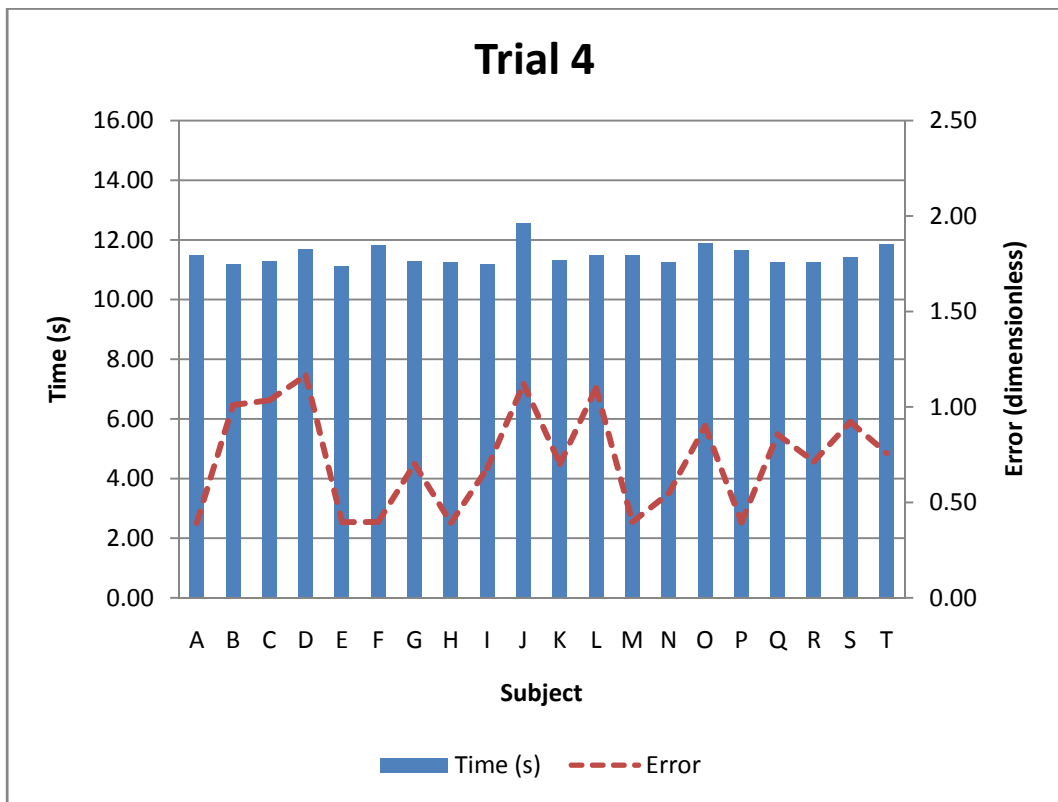

(d)

Figure 5.2: Results from straight track. Refer to Appendix 1(A) for detail (cont.).

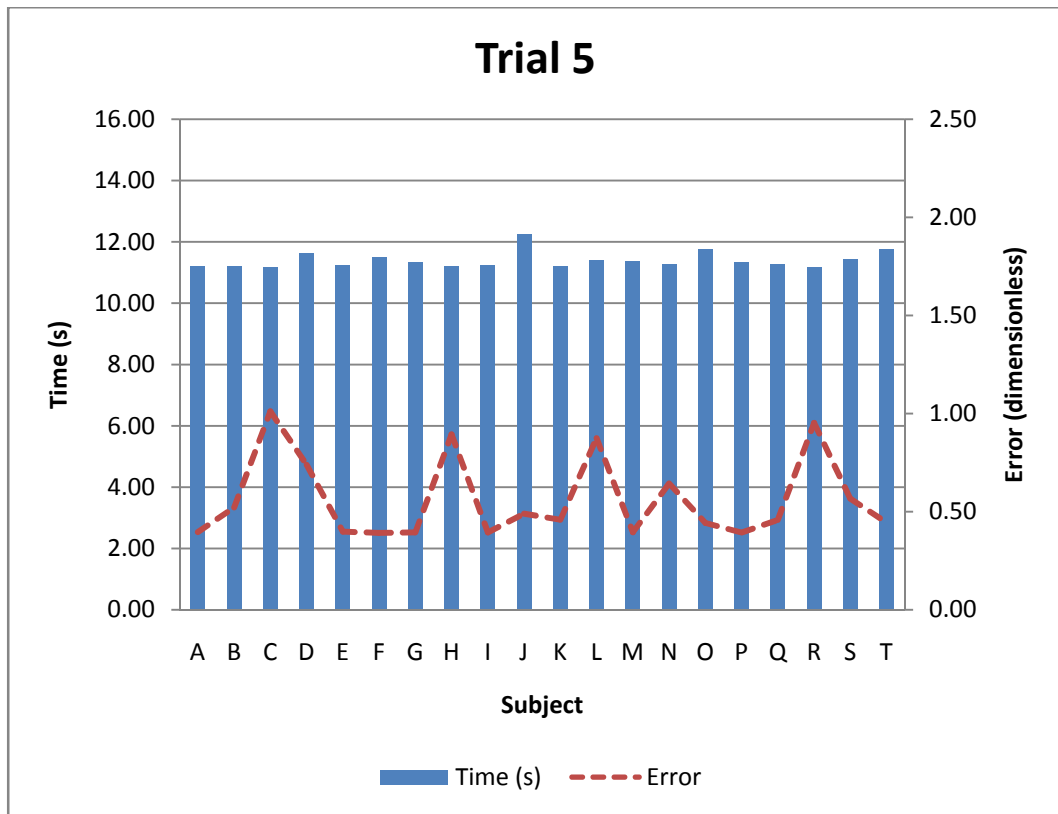

(e)

Figure 5.2: Results from straight track. Refer to Appendix 1(A) for detail (cont.).

For trial 4 (Figure 5.2 (d)), results show that the slowest is Subject J, the fastest (Subject E), the largest error (Subject D) and the smallest error (Subject A and Subject H). Thus, H1 does not supported in trial 4.

For trial 5 (Figure 5.2 (e)), results show that Subject C is the fastest and obtained the largest error. Therefore, these results support hypothesis H1. Other results demonstrate that Subject J is the slowest for second consecutive time and the smallest error (Subject F and Subject P).

For overall, H1 is supported in trial 2, trial 3 and trial 5. Trial 2 and trial 5 show that the fastest time yields the largest error. However, trial 3 demonstrates that the slowest time yields the smallest error. More interestingly, the similar value of the smallest error, which is used in skill index calculation, can be found in trial 3, trial 4 and trial 5.

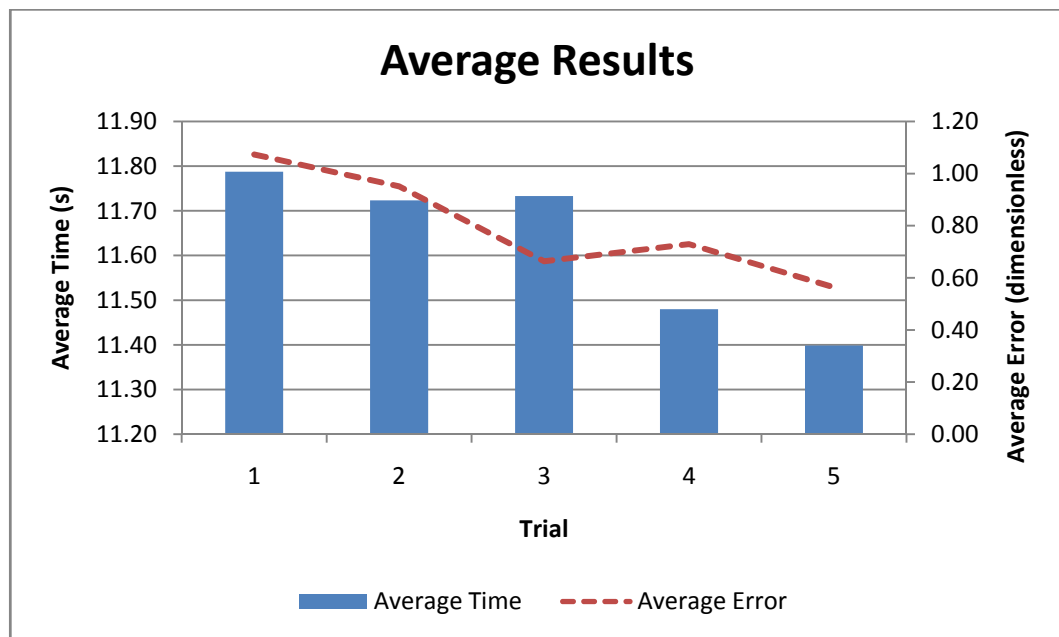

Figure 5.3: Average results for straight track in each trial.

The average time and error for each trial is shown in Figure 5.3. It can be shown that there is a downward trend in both average results after several trials. Therefore, these results support hypotheses, H2 and H3.

5.7.2 CIRCULAR TRACK

Figure 5.4 shows the results from circular track for every subject in each trial. It can be proved that in trial 1 (Figure 5.4(a)), Subject I and Subject E are the slowest and the fastest, respectively. On the other hand, the smallest and the largest errors are obtained by Subject H and Subject A, respectively. Therefore, hypothesis H1 does not supported in trial 1.

For trial 2 (Figure 5.4(b)), the same condition is occurred, where H1 does not supported. Results show that Subject F is the slowest, Subject E (the fastest), Subject A (the smallest error) and Subject B (the largest error).

For trial 3 (Figure 5.4 (c)), Subject F and Subject B are the slowest and the largest error, respectively for second consecutive time. Furthermore, Subject E is obtained the fastest time for third consecutive time. Other result shows that Subject G is obtained the smallest error. Therefore, hypothesis H1 is still unsupported.

For trial 4 (Figure 5.4 (d)), the largest error is obtained by Subject B for third consecutive time. Again, Subject E is obtained the fastest time for fourth consecutive time. Other results show that Subject A is obtained the smallest error and Subject I is the slowest. Therefore, results in trial 4 still do not support hypothesis H1.

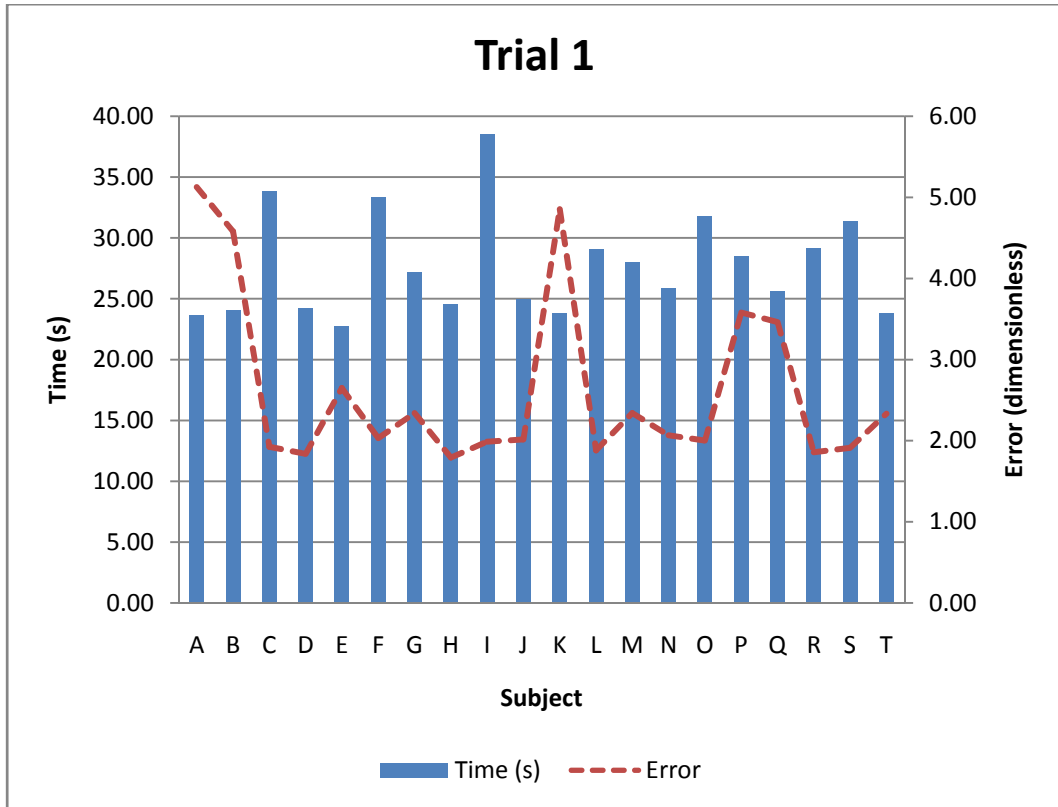

(a)

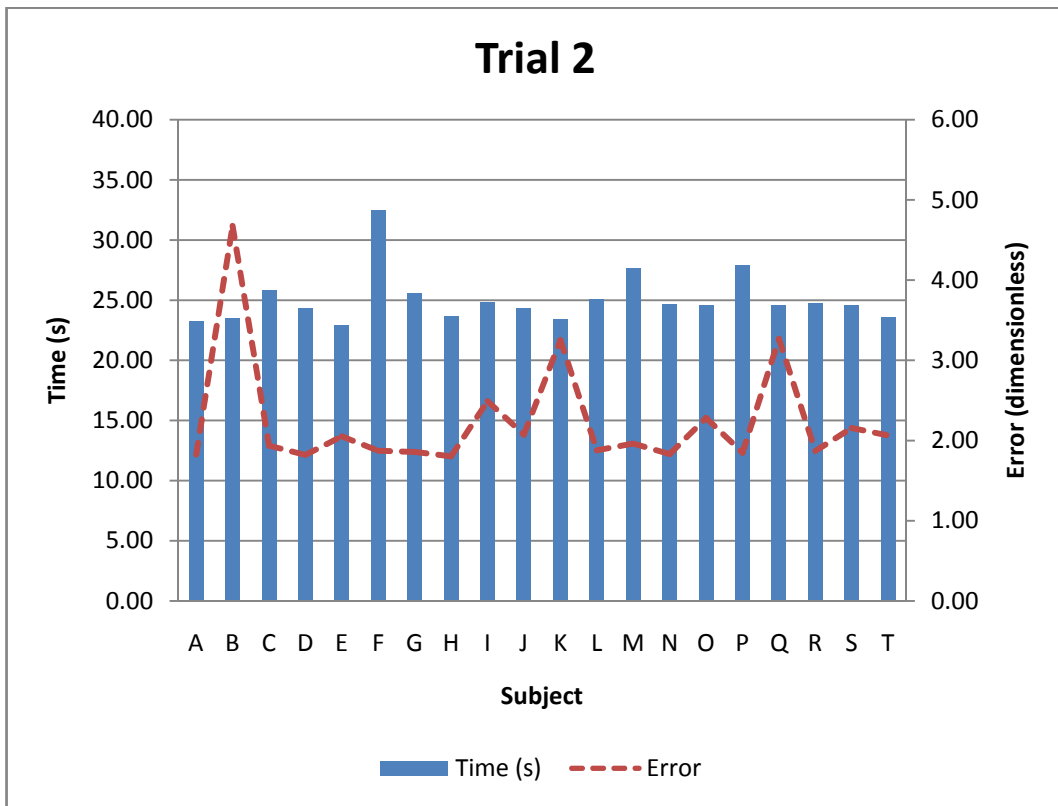

(b)

Figure 5.4: Results from circular track. Refer to Appendix 1(B) for detail.

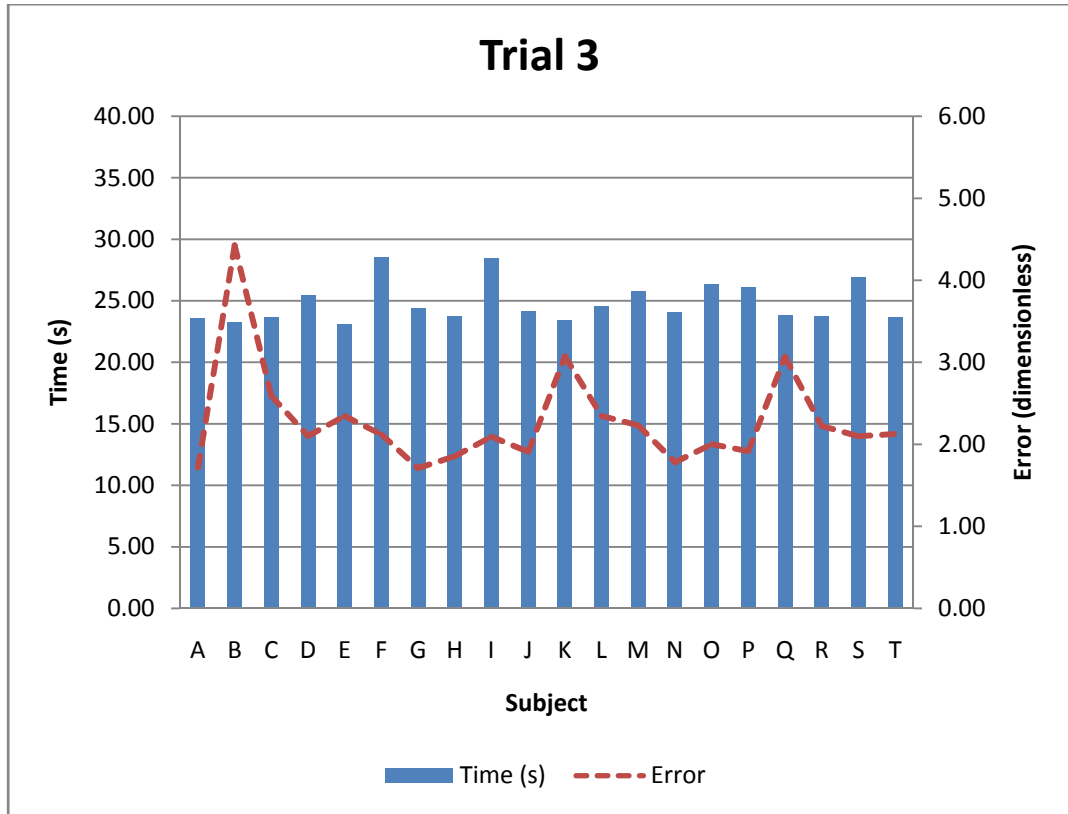

(c)

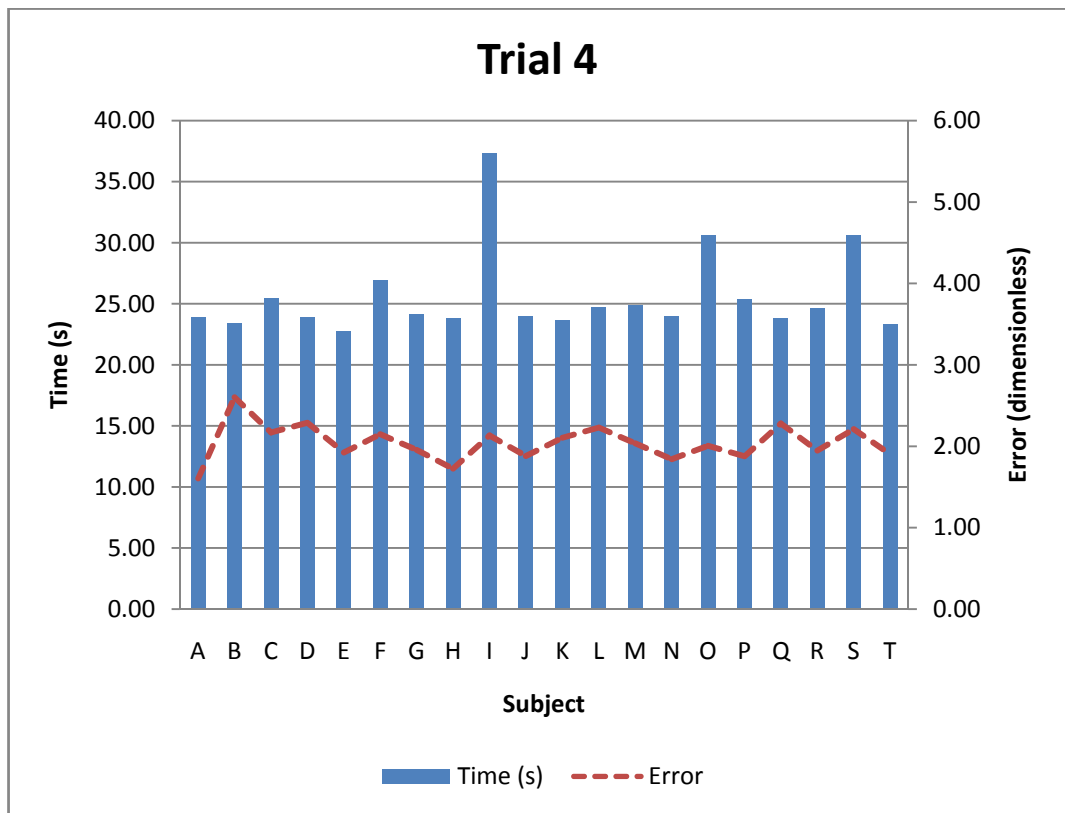

(d)

Figure 5.4: Results from circular track. Refer to Appendix 1(B) for detail (cont.).

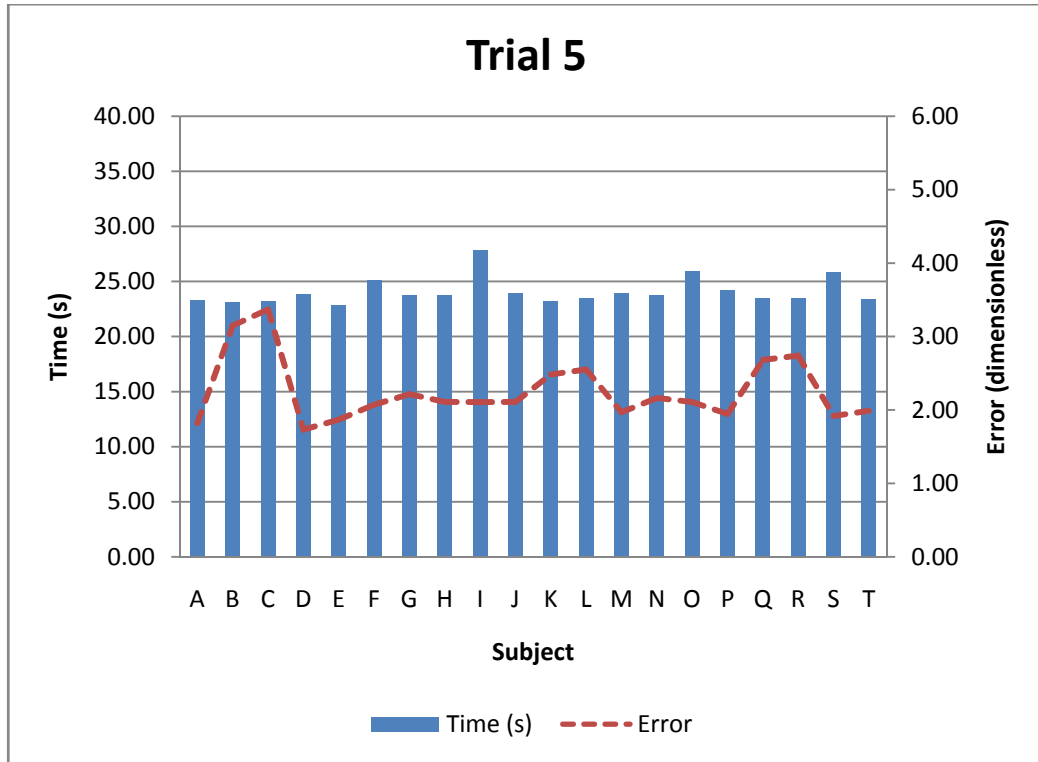

(e)

Figure 5.4: Results from circular track. Refer to Appendix 1(B) for detail (cont.).

Lastly, for trial 5 (Figure 5.4 (e)), Subject C obtained the largest error, Subject D (the smallest error), and Subject I (the slowest). For fifth consecutive time, the fastest time is obtained by Subject E. Thus, trial 5 does not support hypothesis H1. For overall results from circular track, hypothesis H1 does not supported in any trial. No sign shows that the tracking error is inversely proportional to elapsed time in circular track. However, the fastest time is obtainable by the same subject in all five trials, which is Subject E.

Figure 5.5 shows the average time and error in each trial for circular track. It seems that both average results show a downward trend within five trials. Thus, these results support hypotheses H2 and H3.

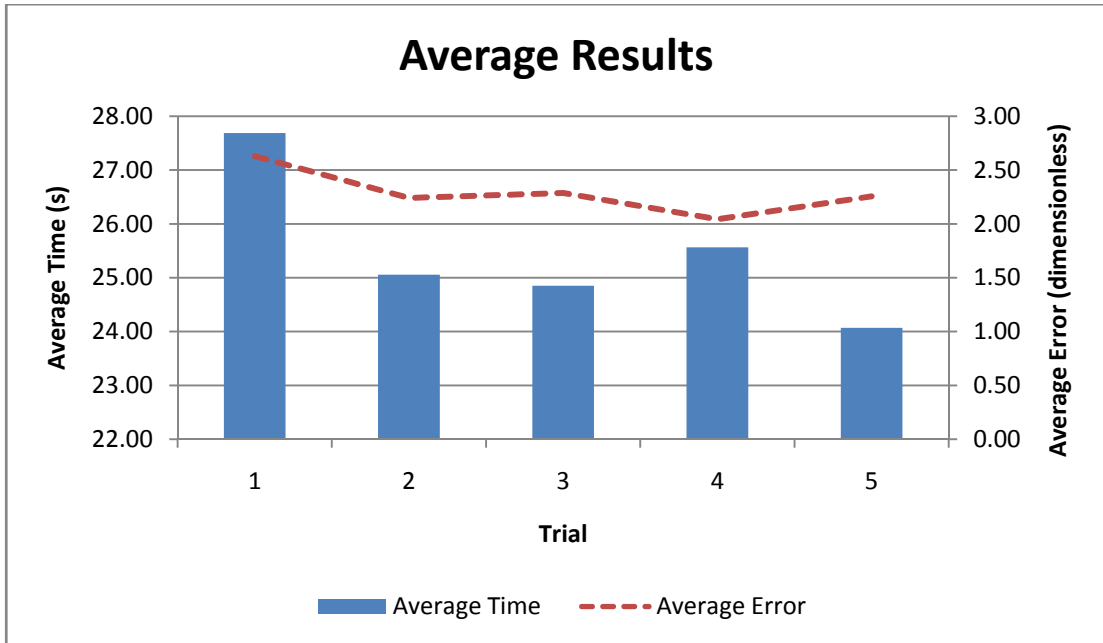
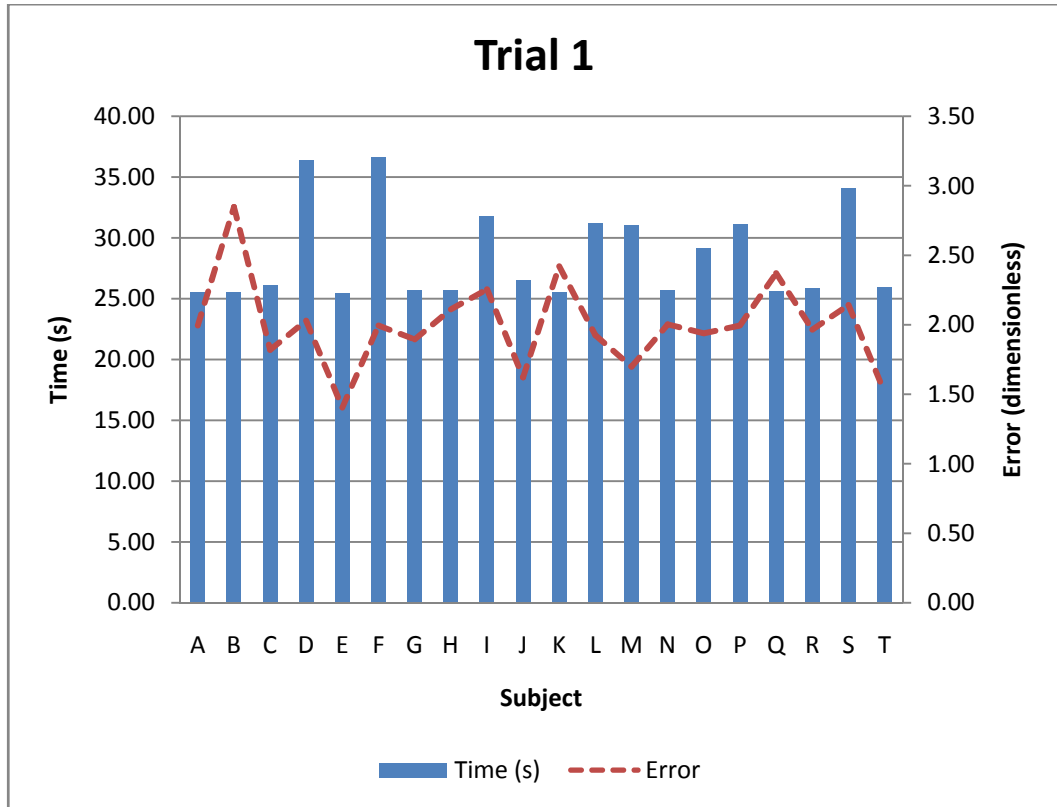

Figure 5.5: Average results for circular track in each trial.

5.7.3 ELLIPTICAL TRACK

Figure 5.6 shows the elapsed time and tracking error for all subjects from elliptical track in every trial. For trial 1 (Figure 5.6 (a)), Subject E is the fastest. However, Subject E is obtained the smallest error. Thus, these results are contradicted with hypothesis H1. Other results show that Subject B and Subject F are obtained the largest error and the slowest time, respectively. Therefore, trial 1 does not support H1.

In trial 2 (Figure 5.6 (b)), results demonstrate that Subject A and Subject B are obtained the smallest and the largest error, respectively. On the other hand, Subject E and Subject F are obtained the fastest and the slowest time, respectively. Thus, trial 2 also does not support H1.



(a)

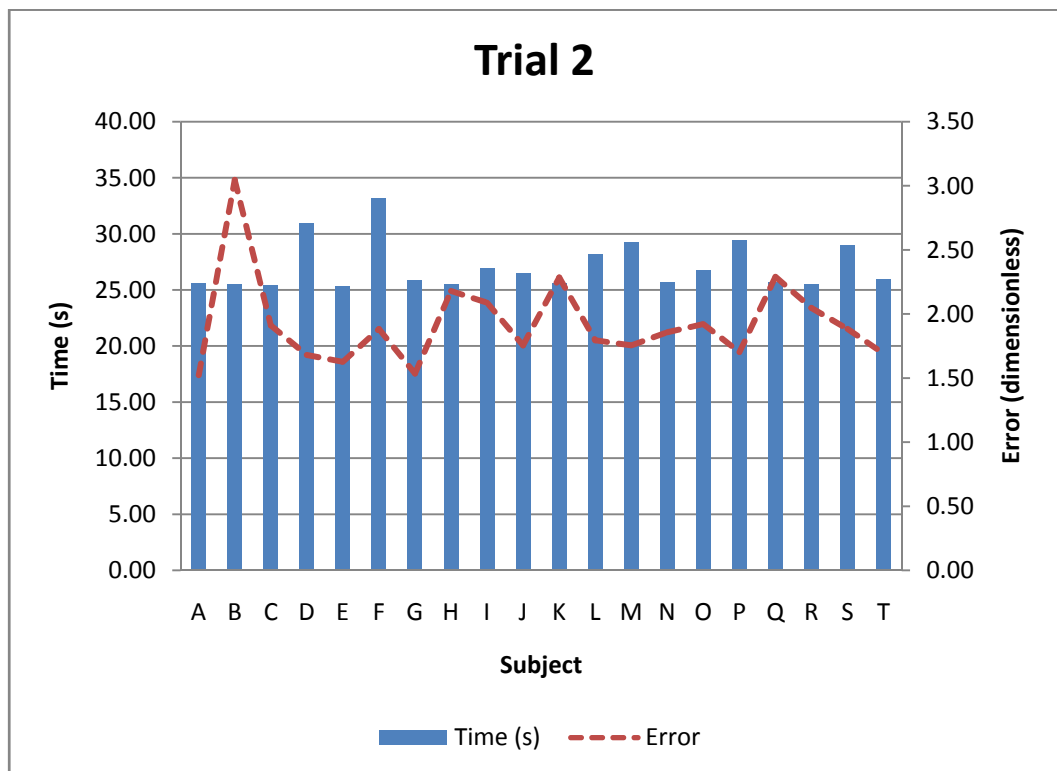

(b)

Figure 5.6: Results from elliptical track. Refer to Appendix 1(C) for detail.

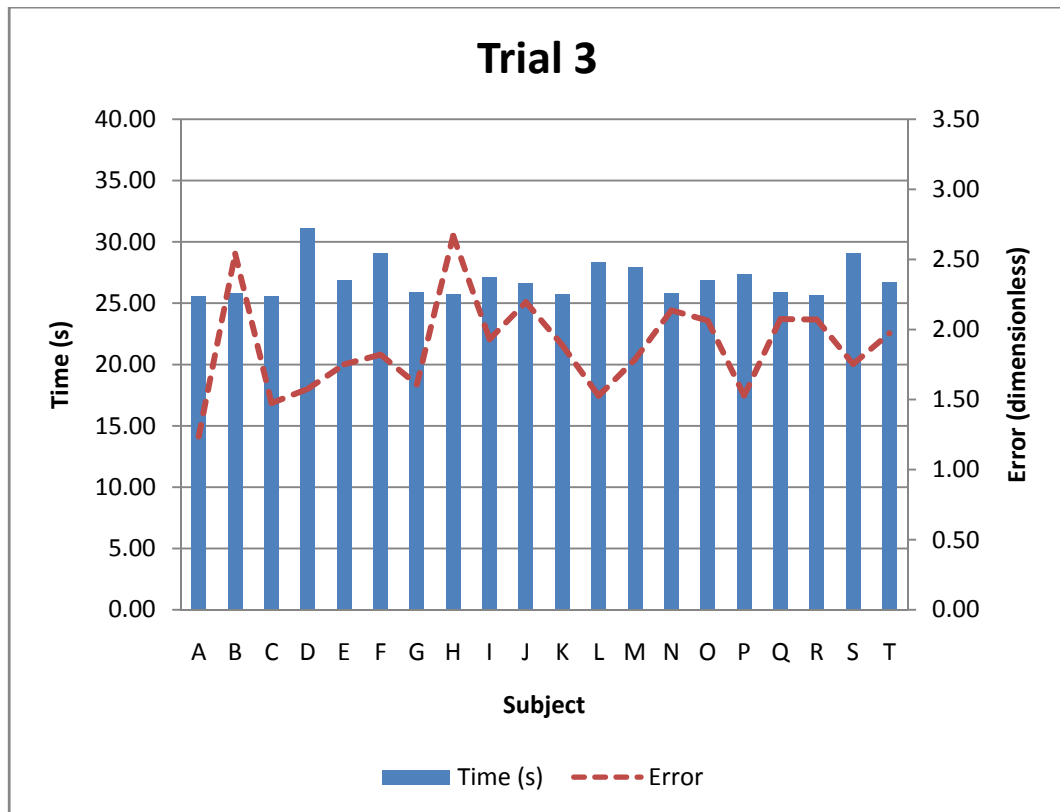

(c)

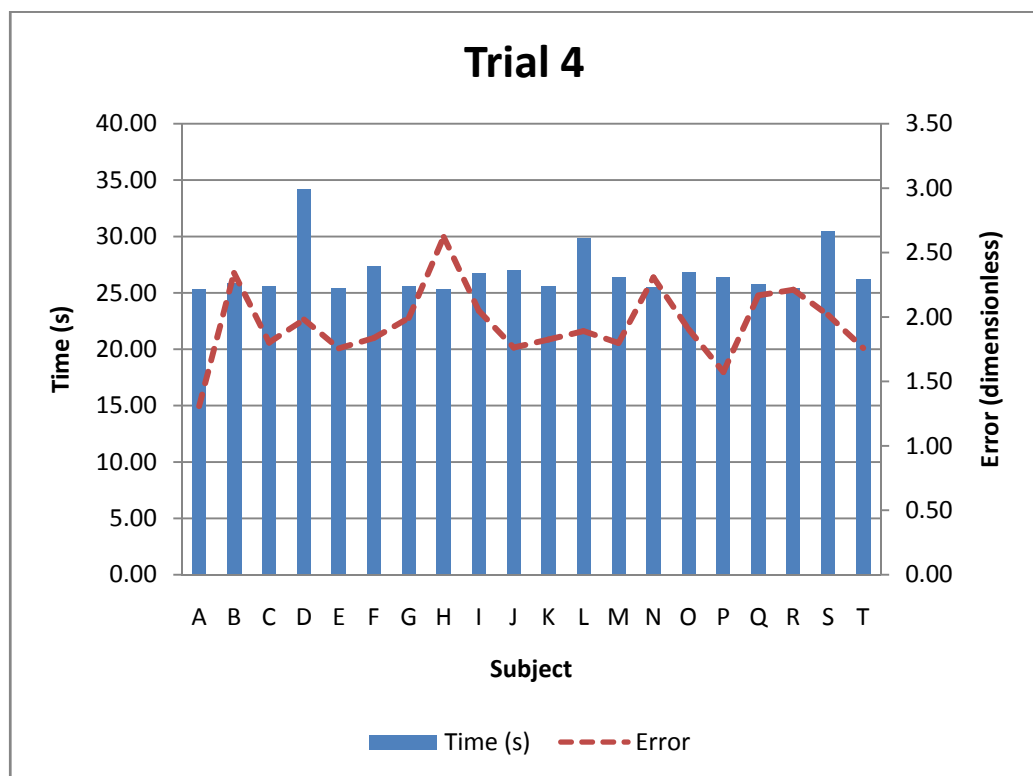

(d)

Figure 5.6: Results from elliptical track. Refer to Appendix 1(C) for detail (cont.).

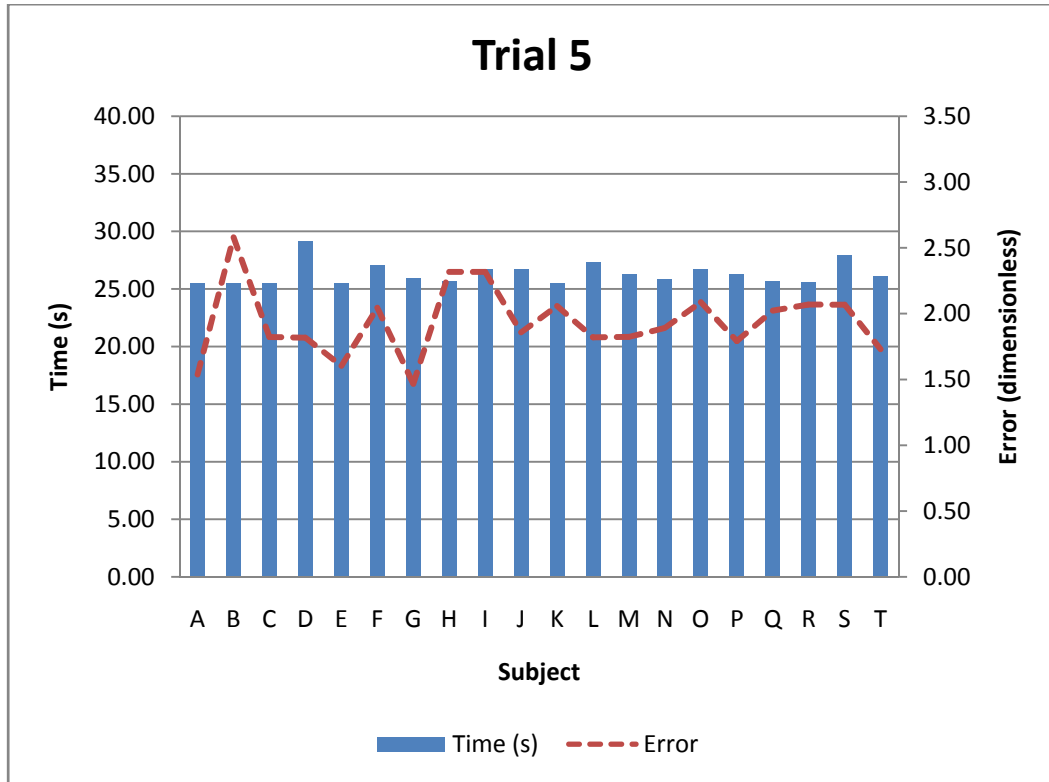

(e)

Figure 5.6: Results from elliptical track. Refer to Appendix 1(C) for detail (cont.).

In trial 3 (Figure 5.6 (c)), Subject A is obtained the smallest error for second consecutive time. Other results in trial 3 show that Subject H, Subject C and Subject D are obtained the largest error, the fastest and the slowest time, respectively. Thus, trial 3 also does not support H1.

In trial 4 (Figure 5.6 (d)), the results are corresponded to hypothesis H1 because Subject H is obtained the fastest time with the largest error. Other results in trial 4 show that Subject A and Subject D are obtained the smallest error and the slowest time, respectively.

Lastly, results in trial 5 (Figure 5.6 (e)) are also corresponded to hypothesis H1, since Subject B is obtained the largest error with the fastest time. Other results in trial 5 demonstrate that Subject G is obtained the smallest error and Subject D is the slowest.

Overall results for elliptical track demonstrate that hypothesis H1 is supported in trial 4 and trial 5, when the fastest subject is obtained the largest error. However, there is no sign that the slowest subject is obtained the smallest error. For average value, the results are shown in Figure 5.7. It can be proved that average elapsed time is decreased within five trials. Thus, the results are supported the hypothesis H2. There is also a downward trend in average error, thus the results are also correspond to hypothesis H3.



Figure 5.7: Average results for elliptical track in each trial.

5.7.4 SQUARE TRACK

The results of elapsed time and the tracking error for square track are shown in Figure 5.8. In trial 1 (Figure 5.8 (a)), it can be shown that Subject D is obtained the smallest error with the slowest time. Thus, hypothesis H1 is supported. Other results in trial 1 demonstrate that Subject G is obtained the largest error and Subject E is the fastest.

In trial 2 (Figure 5.8 (b)), hypothesis H1 is also supported since Subject D is obtained the smallest error with the slowest time again. Apart from that, Subject C and Subject J are obtained the largest error and the fastest time, respectively.

In trial 3 (Figure 5.8 (c)), for third consecutive time, Subject D is obtained the smallest error with the slowest time. Thus, trial 3 is also support hypothesis H1. Other results in trial 3 present that Subject I is obtained largest error and Subject C is the fastest.

In trial 4 (Figure 5.8 (d)), the slowest time is also obtained by Subject D. But, the smallest time is obtained by Subject F. The fastest time is Subject E and the largest error is obtained by Subject C. Thus, trial 4 does not support hypothesis H1.

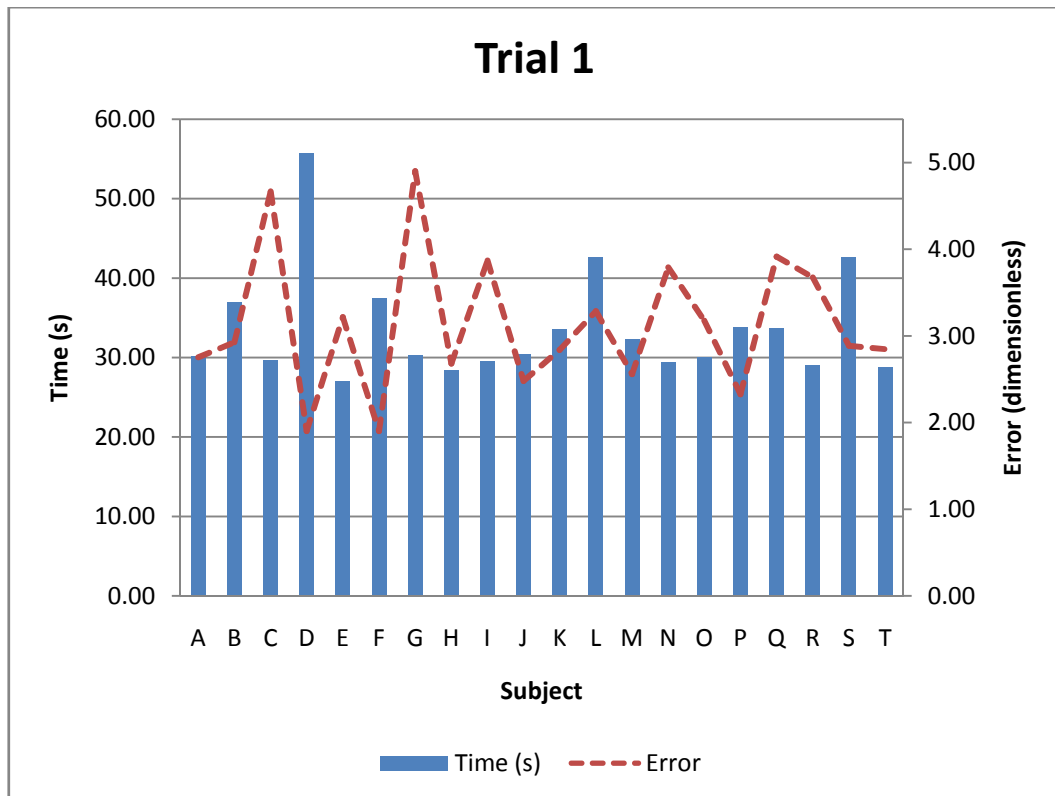

(a)

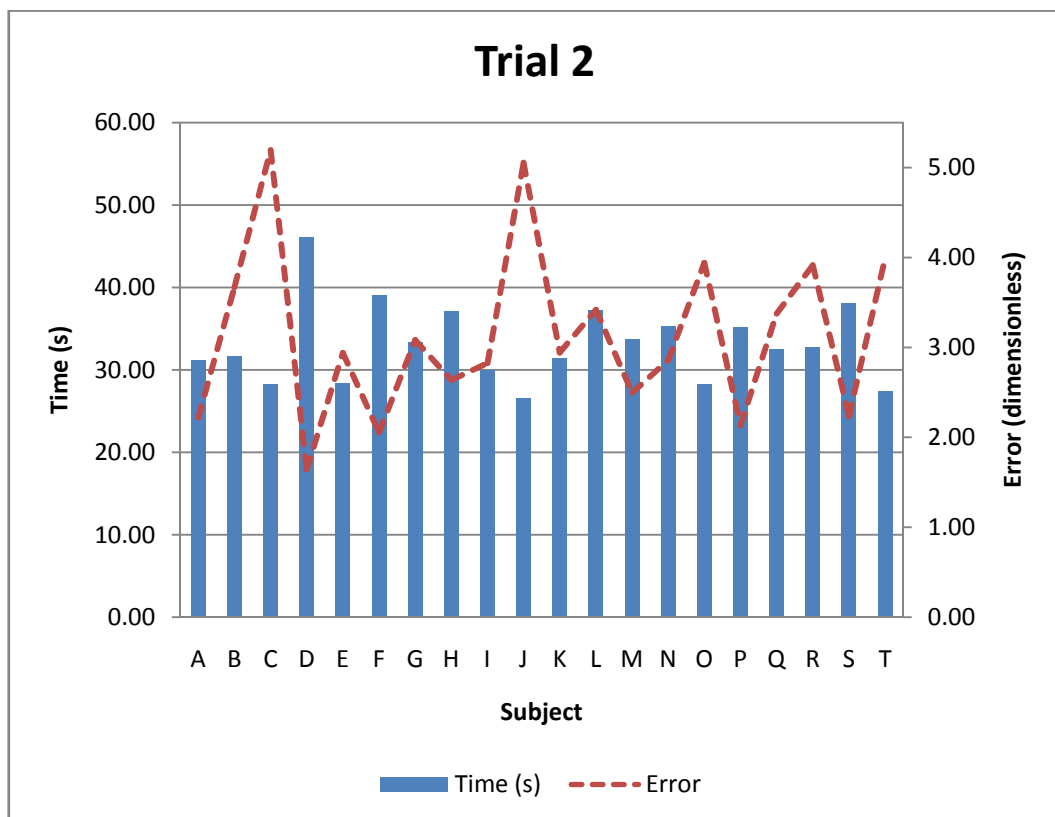

(b)

Figure 5.8: Results from square track. Refer to Appendix 1(D) for detail.

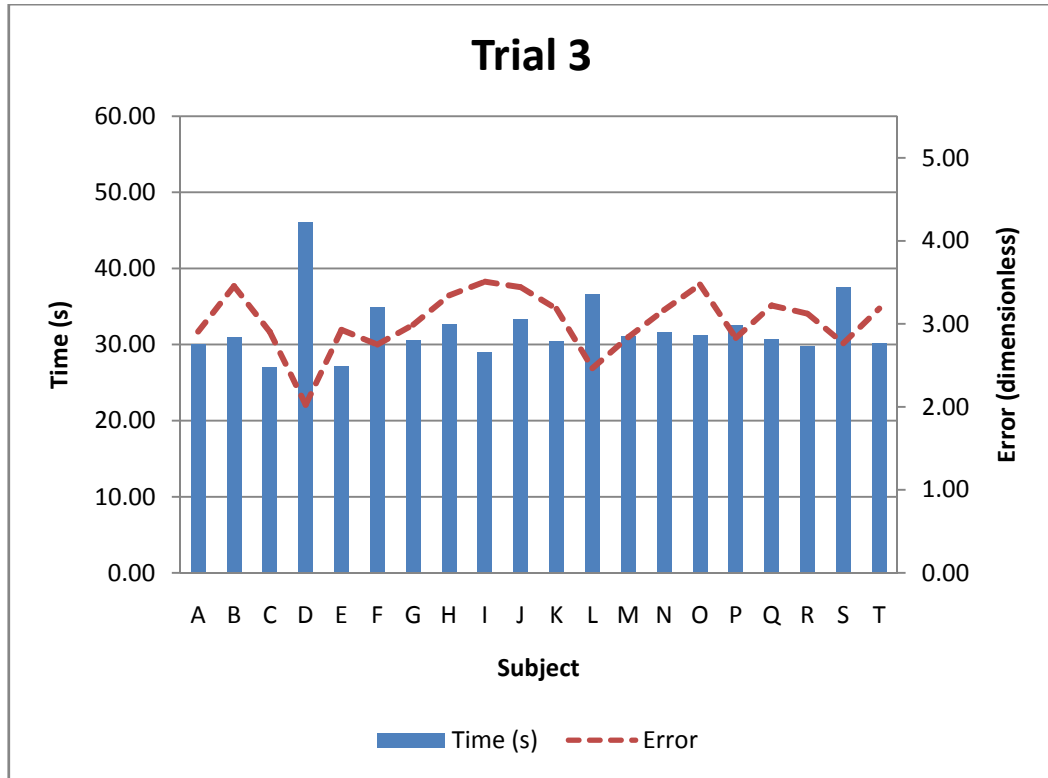

(c)

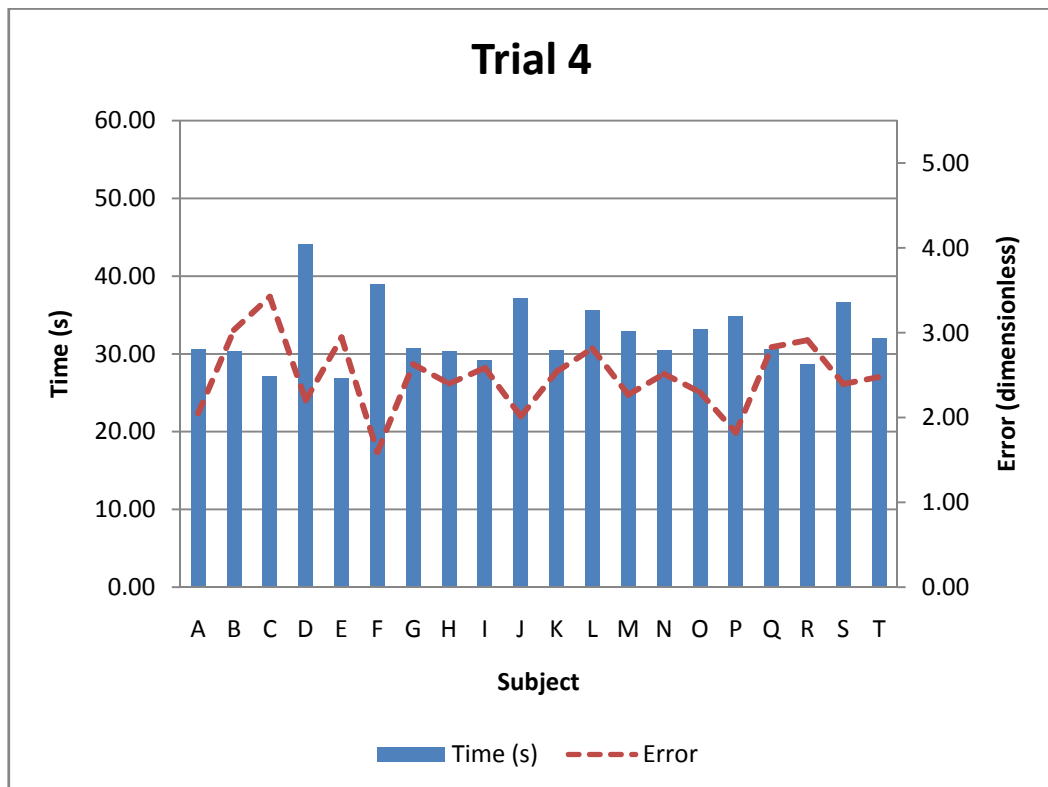

(d)

Figure 5.8: Results from square track. Refer to Appendix 1(D) for detail (cont.).

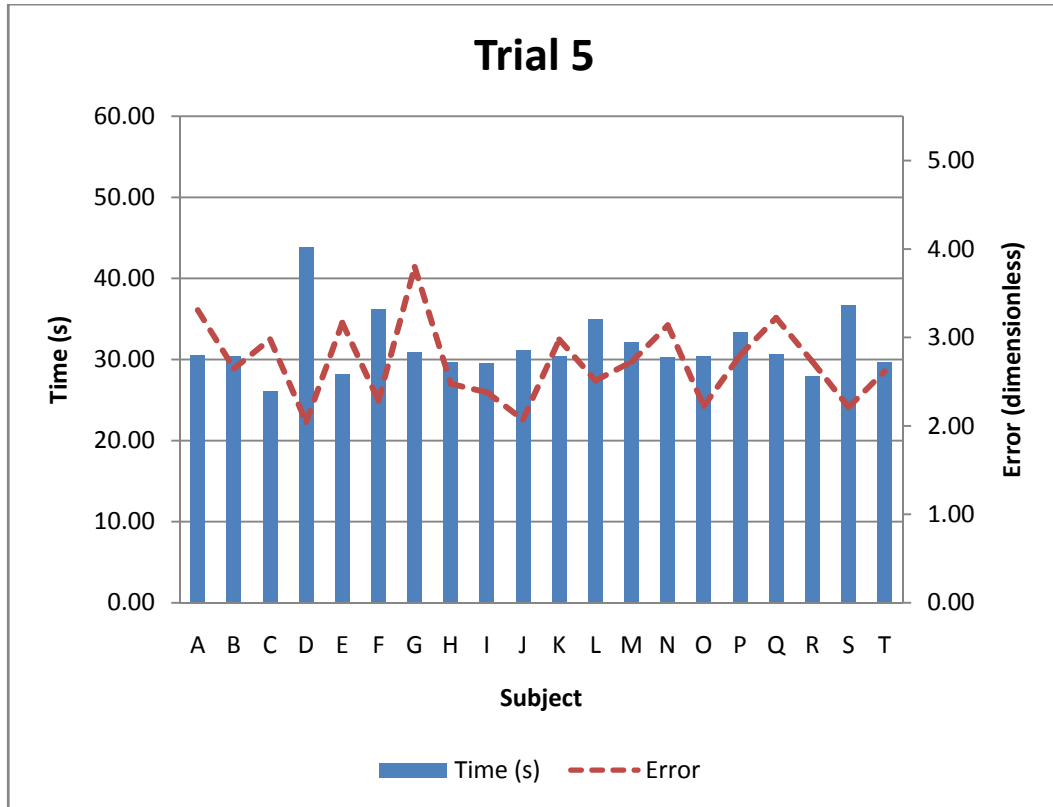

(e)

Figure 5.8: Results from square track. Refer to Appendix 1(D) for detail (cont.).

Lastly, in trial 5 (Figure 5.8 (e)), Subject D is obtained the smallest error with the slowest time for fourth time. Thus, trial 5 is support hypothesis H1. Other results in trial 5 show that Subject G and Subject C are obtained the largest error and the fastest time, respectively.

Overall results from square track show that hypothesis H1 is supported in all trials except trial 4. It seems that the slowest time yields the smallest error in driving through square track. In addition, the value of the average time and error for each trial is shown in Figure 5.9. It shows that there is a downward trend in both average results after several trials. Thus, these results are supported hypotheses H2 and H3.

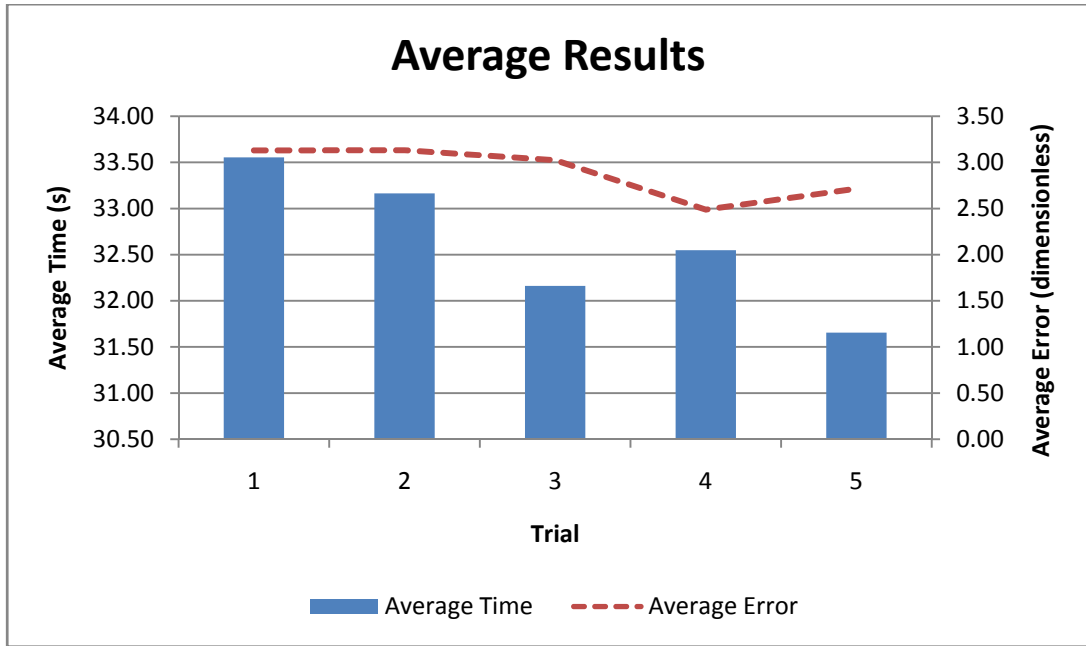
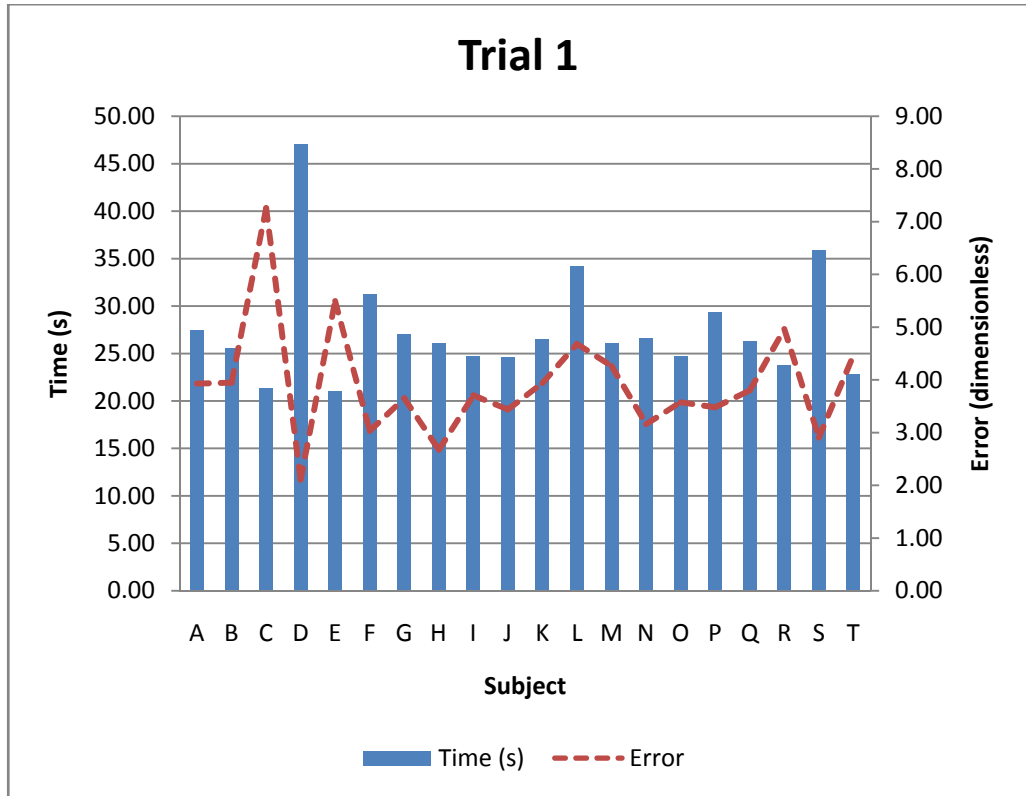

Figure 5.9: Average results for square track in each trial.

5.7.5 TRIANGULAR TRACK

Figure 5.10 shows the results of elapsed time and tracking error for each subject from triangular track in every trial. In trial 1 (Figure 5.10 (a)), Subject D is obtained the smallest error and the slowest time. Thus, these results are support hypothesis H1. Other results from trial 1 show that Subject C and Subject E are obtained the largest error and the fastest time, respectively.

In trial 2 (Figure 5.10 (b)), hypothesis H1 is also supported when Subject C is obtained the largest error with the fastest time. For second consecutive time, Subject D is obtained the slowest time but does not correspond to H1. Apart from that, Subject A is obtained the smallest error.



(a)

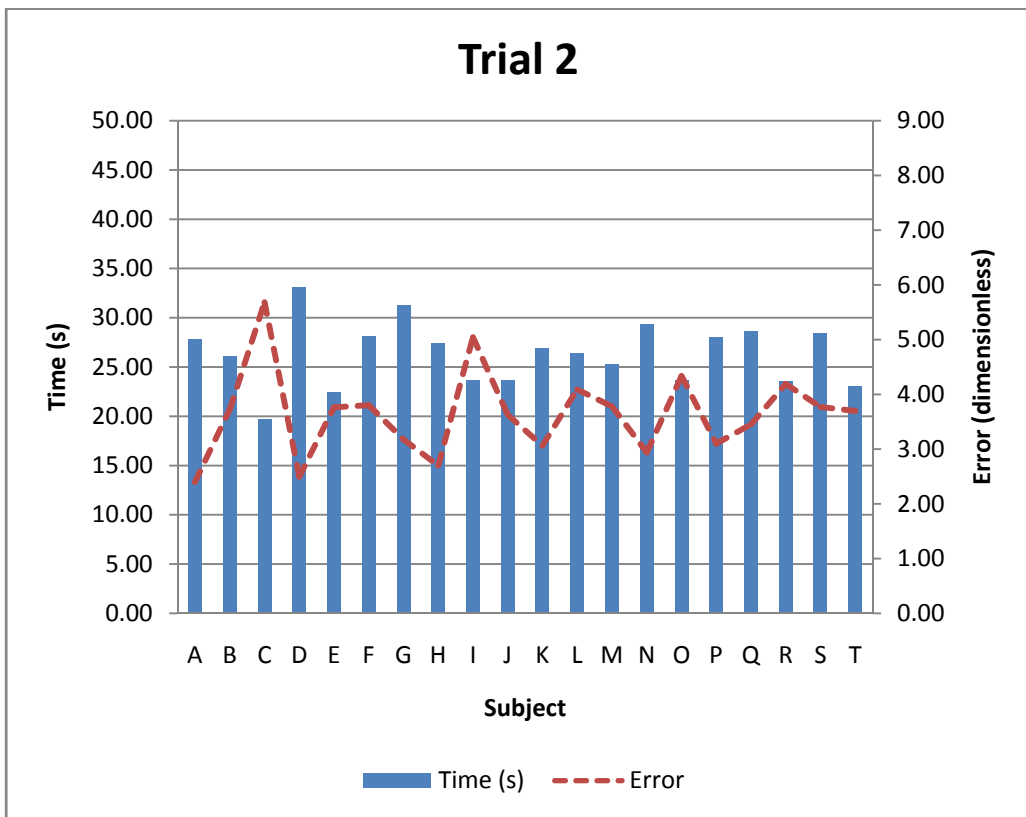

(b)

Figure 5.10: Results from triangular track. Refer to Appendix 1(E) for detail.

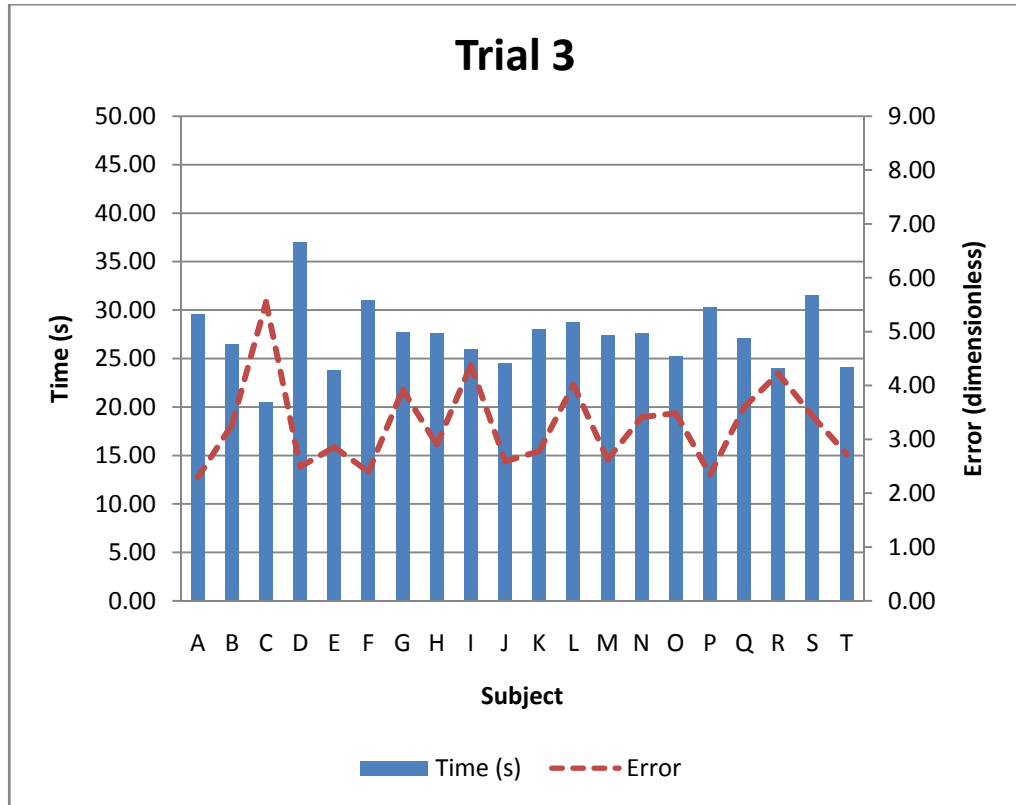

(c)

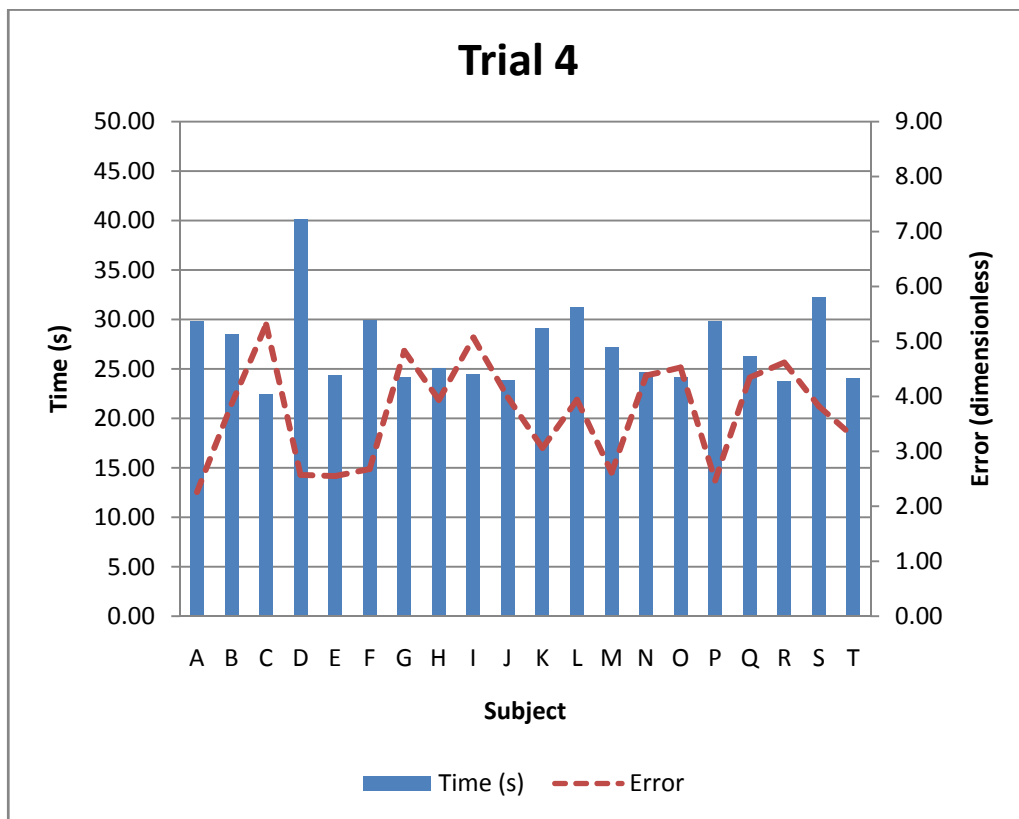

(d)

Figure 5.10: Results from triangular track. Refer to Appendix 1(E) for detail (cont.).

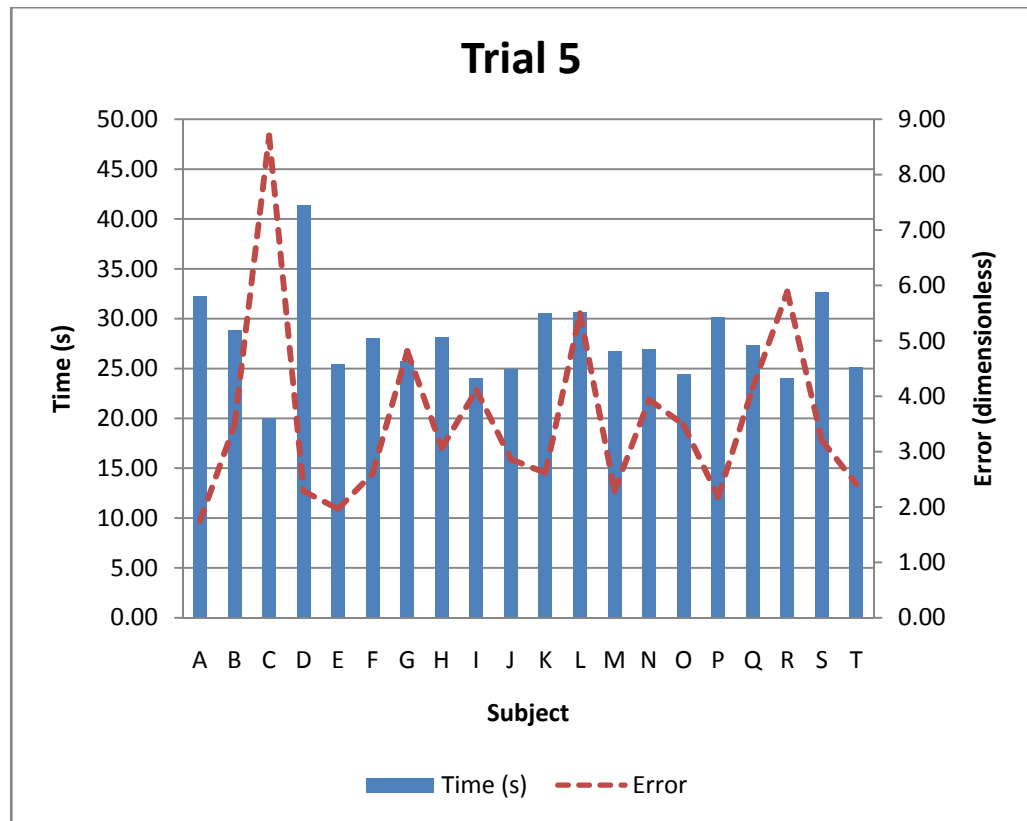

(e)

Figure 5.10: Results from triangular track. Refer to Appendix 1(E) for detail (cont.).

In trial 3 (Figure 5.10 (c)), Subject C is obtained the largest error with the fastest time again. Thus, these results are also corresponded to hypothesis H1. Other results show that Subject A and Subject D are obtained the smallest error and the slowest time, respectively.

Similar conditions happened in trial 4 and trial 5, where Subject C is obtained the largest error with the fastest time, Subject A (the smallest error) and Subject D (the slowest). Thus, hypothesis H1 is also supported in trial 4 and trial 5.

Overall results from triangular track show that hypothesis H1 is supported in all five trials. In trial 1, the slowest time yields the smallest error. In other trials, the fastest time yields the largest error.

Figure 5.11 shows the average results for time and error from triangular track. It clearly shows that both average time is fluctuates considerably within five trials. In other words, these results do not support hypotheses H2 and H3.

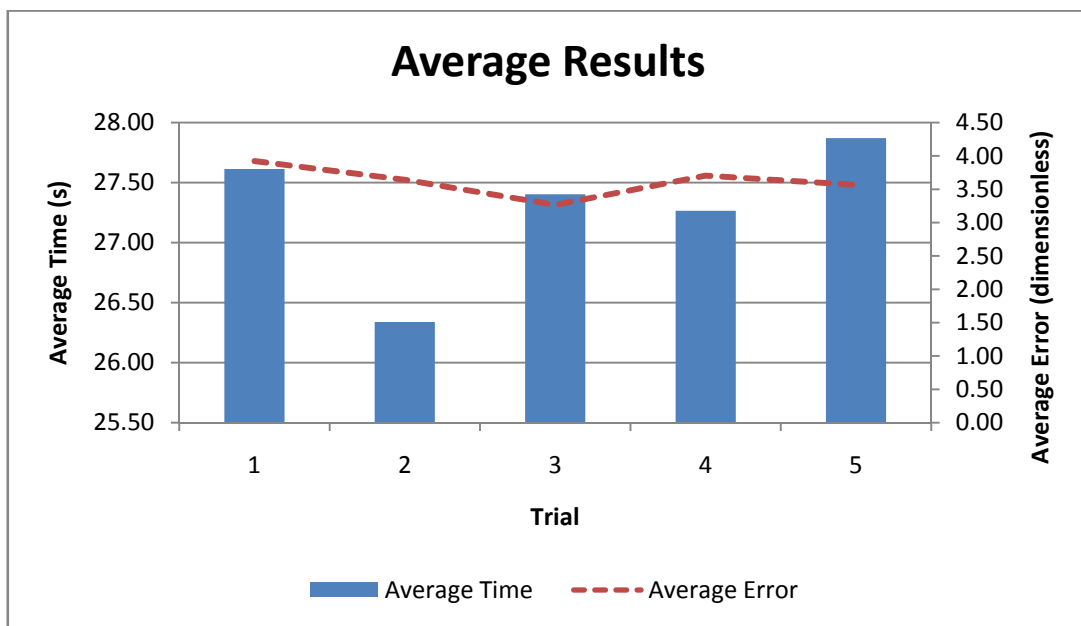

Figure 5.11: Average results for triangular track in each trial.

5.8 ANALYSIS

5.8.1 SMALLEST POSSIBLE ERROR, E_s

Based on the proposed rules in Chapter 4.3.1, the smallest possible error for each track in EGC is obtained and shown in Table 5.2. It seems that Subject F obtained the smallest error for straight and square tracks from trial 5 and 4, respectively. For other tracks, the smallest error is obtained by Subject A. However, there is no rationale can explain that only these two subjects (Subject A and Subject F) obtained the smallest error in this experiment. It might be happened because of coincident and unexplainable. These values of E_s are then used in the entire calculation of normalized error for all subjects in both main experiments.

Table 5.2: E_s for each track

Track	Smallest error obtained by subject	Smallest possible error, E_s	Subject	Trial
Straight	0.39	0.35	F	5
Circular	1.61	1.60	A	4
Elliptical	1.24	1.20	A	3
Square	1.59	1.55	F	4
Triangular	1.75	1.70	A	5

5.8.2 AVERAGE ERROR

From Table 5.3, it clearly shows that a higher tracking error is obtained from square and triangular tracks. These tracks have more bends and corners, thus the experimental results are totally support hypothesis H4.

Table 5.3: Average error for each track

Track	Average error (Dimensionless)
Straight	0.80
Circular	2.29
Elliptical	1.94
Square	2.90
Triangular	3.62

5.8.3 SKILL INDEX

Based on the proposed formula in Chapter 4.4.4, the skill index of each subject in every track is calculated and presented in Table 5.4, Table 5.5, Table 5.6, Table 5.7 and Table 5.8. For every normalized data of elapsed time and tracking error, please refer to Appendix 2.

Based on Table 5.4, it seems that only three subjects are HS for the first two trials when driving through a straight track. No subject is HS in all trial although the track is just a straight line. However, the number of HS subject is increased rapidly in the last three trials. It shows that 11 subjects are HS in trial 3, eight in trial 4 and finally, 15 in trial 5. These conditions conclude that most human subjects are still unfamiliar with the driving simulator for the first two trials and get familiar started from trial 3.

Table 5.4: Skill index value and class for each subject from straight track

Subject	Skill index, J					Class				
	1	2	3	4	5	1	2	3	4	5
A	0.48	0.81	0.78	0.81	0.81	MS	HS	HS	HS	HS
B	0.62	0.53	0.57	0.54	0.71	MS	MS	MS	MS	HS
C	0.51	0.48	0.55	0.54	0.55	MS	MS	MS	MS	MS
D	0.55	0.72	0.63	0.51	0.59	MS	HS	HS	MS	MS
E	0.51	0.52	0.81	0.81	0.81	MS	MS	HS	HS	HS
F	0.49	0.45	0.77	0.79	0.81	MS	MS	HS	HS	HS
G	0.69	0.55	0.73	0.62	0.81	HS	MS	HS	MS	HS
H	0.45	0.51	0.55	0.81	0.57	MS	MS	MS	HS	MS
I	0.66	0.59	0.53	0.63	0.81	HS	MS	MS	HS	HS
J	0.52	0.58	0.64	0.49	0.70	MS	MS	HS	MS	HS
K	0.52	0.61	0.64	0.62	0.75	MS	MS	HS	MS	HS
L	0.52	0.53	0.58	0.52	0.56	MS	MS	MS	MS	MS
M	0.48	0.48	0.79	0.80	0.81	MS	MS	HS	HS	HS
N	0.50	0.53	0.61	0.69	0.64	MS	MS	MS	HS	HS
O	0.57	0.58	0.57	0.54	0.75	MS	MS	MS	MS	HS
P	0.46	0.56	0.77	0.80	0.81	MS	MS	HS	HS	HS
Q	0.65	0.54	0.63	0.57	0.75	HS	MS	HS	MS	HS
R	0.48	0.49	0.55	0.61	0.55	MS	MS	MS	MS	MS
S	0.60	0.63	0.56	0.55	0.67	MS	HS	MS	MS	HS
T	0.51	0.54	0.72	0.58	0.75	MS	MS	HS	MS	HS

Although straight track can be considered as the easiest track, but this track requires more concentration from the human subject. In other words, if the subject does the small mistake in following the line, it might easily influence the time as well as the error. On top of that, the reference values for time and error, which is the fastest and the smallest, respectively, are also much better than the actual values obtained by the subjects because these values are measured from either the calculation or the best trial

among subjects. These values mainly affect the normalized data of each subject.

However, in general, H5 is supported for straight track.

Table 5.5: Skill index value and class for each subject from circular track

Subject	Skill index					Class				
	1	2	3	4	5	1	2	3	4	5
A	0.49	0.78	0.80	0.83	0.78	MS	HS	HS	HS	HS
B	0.50	0.51	0.52	0.64	0.60	MS	MS	MS	HS	MS
C	0.65	0.72	0.64	0.68	0.58	HS	HS	HS	HS	MS
D	0.76	0.76	0.69	0.68	0.79	HS	HS	HS	HS	HS
E	0.65	0.74	0.68	0.76	0.77	HS	HS	HS	HS	HS
F	0.63	0.67	0.65	0.67	0.70	HS	HS	HS	HS	HS
G	0.63	0.74	0.79	0.74	0.69	HS	HS	HS	HS	HS
H	0.77	0.78	0.76	0.80	0.71	HS	HS	HS	HS	HS
I	0.61	0.64	0.66	0.59	0.66	MS	HS	HS	MS	HS
J	0.71	0.71	0.75	0.76	0.71	HS	HS	HS	HS	HS
K	0.50	0.58	0.60	0.71	0.66	MS	MS	MS	HS	HS
L	0.70	0.74	0.66	0.68	0.65	HS	HS	HS	HS	HS
M	0.62	0.69	0.66	0.71	0.74	MS	HS	HS	HS	HS
N	0.69	0.76	0.78	0.76	0.70	HS	HS	HS	HS	HS
O	0.65	0.67	0.70	0.66	0.68	HS	HS	HS	HS	HS
P	0.50	0.72	0.72	0.74	0.74	MS	HS	HS	HS	HS
Q	0.54	0.57	0.59	0.68	0.64	MS	MS	MS	HS	HS
R	0.70	0.75	0.69	0.73	0.63	HS	HS	HS	HS	HS
S	0.67	0.69	0.67	0.62	0.72	HS	HS	HS	MS	HS
T	0.67	0.72	0.71	0.76	0.74	HS	HS	HS	HS	HS

For circular track, based on Table 5.5, it is observed that 12 out of 20 subjects are HS in all five trials. Although there is only 13 subjects are HS for trial 1, but this number is increased rapidly to at least 17 subjects for trial 2 until trial 5. Just a few subjects are obtained MS in this track. By considering the circular as second track in this

experiment, it can be summarized that subjects are already getting familiar with the driving simulator and the track is become easier to follow. For this track, H5 is totally supported.

Table 5.6: Skill index value and class for each subject from elliptical track

Subject	Skill index, J					Class				
	1	2	3	4	5	1	2	3	4	5
A	0.66	0.75	0.84	0.82	0.75	HS	HS	HS	HS	HS
B	0.57	0.55	0.59	0.61	0.59	MS	MS	MS	MS	MS
C	0.68	0.67	0.76	0.69	0.69	HS	HS	HS	HS	HS
D	0.55	0.65	0.67	0.57	0.64	MS	HS	HS	MS	HS
E	0.79	0.73	0.68	0.70	0.73	HS	HS	HS	HS	HS
F	0.55	0.59	0.64	0.66	0.63	MS	MS	HS	HS	HS
G	0.67	0.74	0.73	0.66	0.76	HS	HS	HS	HS	HS
H	0.64	0.63	0.58	0.59	0.62	HS	HS	MS	MS	MS
I	0.55	0.63	0.65	0.64	0.60	MS	HS	HS	HS	MS
J	0.72	0.69	0.62	0.68	0.67	HS	HS	MS	HS	HS
K	0.61	0.62	0.67	0.69	0.65	MS	MS	HS	HS	HS
L	0.60	0.66	0.72	0.62	0.66	MS	HS	HS	MS	HS
M	0.65	0.65	0.66	0.68	0.68	HS	HS	HS	HS	HS
N	0.66	0.68	0.63	0.62	0.67	HS	HS	HS	MS	HS
O	0.62	0.65	0.63	0.66	0.63	MS	HS	HS	HS	HS
P	0.59	0.66	0.73	0.73	0.68	MS	HS	HS	HS	HS
Q	0.61	0.62	0.64	0.63	0.65	MS	MS	HS	HS	HS
R	0.66	0.65	0.65	0.63	0.65	HS	HS	HS	HS	HS
S	0.55	0.63	0.66	0.60	0.62	MS	HS	HS	MS	MS
T	0.75	0.71	0.65	0.69	0.70	HS	HS	HS	HS	HS

Table 5.6 shows the skill index for every subject in elliptical track. Although all subjects are considered familiar with the simulation environment in second track, but for elliptical track which is the third track in experiment, the number of HS subject in

all trial is decreased to only seven subjects. Although both tracks are designed to measure the skill in nonlinear line and continuous cornering, but this shows that the elliptical track is more difficult than the circular track. Moreover, there is a subject obtained only MS in all trial. However, for this track, H5 is still supported in general.

Table 5.7: Skill index value and class for each subject from square track

Subject	Skill index, J					Class				
	1	2	3	4	5	1	2	3	4	5
A	0.66	0.71	0.64	0.75	0.60	HS	HS	HS	HS	HS
B	0.57	0.57	0.59	0.63	0.66	MS	MS	MS	HS	HS
C	0.55	0.55	0.68	0.64	0.69	MS	MS	HS	HS	HS
D	0.61	0.72	0.63	0.61	0.64	MS	HS	HS	MS	HS
E	0.66	0.66	0.68	0.68	0.64	HS	HS	HS	HS	HS
F	0.71	0.66	0.60	0.77	0.65	HS	HS	MS	HS	HS
G	0.53	0.59	0.63	0.66	0.57	MS	MS	HS	MS	HS
H	0.68	0.60	0.58	0.69	0.69	HS	MS	MS	HS	HS
I	0.58	0.65	0.61	0.68	0.71	MS	HS	MS	HS	HS
J	0.68	0.58	0.56	0.69	0.74	HS	MS	MS	HS	HS
K	0.61	0.62	0.61	0.67	0.63	MS	MS	MS	HS	HS
L	0.50	0.53	0.62	0.59	0.63	MS	MS	MS	MS	HS
M	0.65	0.64	0.64	0.68	0.63	HS	HS	HS	HS	HS
N	0.59	0.59	0.60	0.68	0.62	MS	MS	MS	HS	MS
O	0.62	0.60	0.58	0.68	0.72	MS	MS	MS	HS	HS
P	0.67	0.68	0.62	0.75	0.61	HS	HS	MS	HS	MS
Q	0.53	0.58	0.61	0.64	0.61	MS	MS	MS	HS	MS
R	0.60	0.54	0.63	0.66	0.69	MS	MS	HS	HS	HS
S	0.53	0.64	0.58	0.63	0.66	MS	HS	MS	HS	HS
T	0.66	0.60	0.62	0.66	0.68	HS	MS	MS	HS	HS

Based on Table 5.7, the total number of HS in all trial from square track is decreased to only two subjects. However, despite only seven to eight subjects obtained HS in the

first three trials, the number of HS is increased rapidly in trial 4 and trial 5. This can be concluded that majority of subjects have the difficulties in following the linear line with 90° of corners in the first three trials. However, H5 is still supported when most subjects are improved their skills in the last two trials.

Table 5.8: Skill index value and class for each subject from triangular track

Subject	Skill index, J					Class				
	1	2	3	4	5	1	2	3	4	5
A	0.52	0.65	0.65	0.66	0.75	MS	HS	HS	HS	HS
B	0.54	0.55	0.58	0.51	0.53	MS	MS	MS	MS	MS
C	0.51	0.57	0.56	0.53	0.52	MS	MS	MS	MS	MS
D	0.58	0.59	0.57	0.54	0.57	MS	MS	MS	MS	MS
E	0.55	0.60	0.65	0.68	0.76	MS	MS	HS	HS	HS
F	0.55	0.52	0.62	0.60	0.62	MS	MS	MS	MS	MS
G	0.54	0.53	0.52	0.52	0.50	MS	MS	MS	MS	MS
H	0.64	0.62	0.60	0.55	0.57	HS	MS	MS	MS	MS
I	0.57	0.52	0.52	0.51	0.55	MS	MS	MS	MS	MS
J	0.59	0.59	0.67	0.56	0.63	MS	MS	HS	MS	HS
K	0.53	0.59	0.60	0.56	0.60	MS	MS	MS	MS	MS
L	0.43	0.52	0.50	0.48	0.43	MS	MS	MS	MS	MS
M	0.52	0.55	0.63	0.63	0.68	MS	MS	HS	HS	HS
N	0.58	0.57	0.55	0.53	0.53	MS	MS	MS	MS	MS
O	0.58	0.55	0.57	0.53	0.59	MS	MS	MS	MS	MS
P	0.53	0.57	0.64	0.62	0.67	MS	MS	HS	HS	HS
Q	0.54	0.54	0.54	0.51	0.51	MS	MS	MS	MS	MS
R	0.52	0.56	0.55	0.54	0.49	MS	MS	MS	MS	MS
S	0.53	0.52	0.51	0.48	0.52	MS	MS	MS	MS	MS
T	0.56	0.59	0.66	0.61	0.68	HS	MS	MS	MS	HS

Lastly, Table 5.8 shows the skill index for each subject in triangular track. Based on Table 5.8, majority of subjects are MS in all trials. Although the subjects are guided in following the track, but it can be assumed that 60° of corners are very tricky, when the subjects making a short cut or sometimes a long cut in order to simplify the cornering process. Thus, these actions yield the bigger error and affect the skill index. Although there are six subjects improved their skill after several trials, but generally, H5 is not supported.

5.8.4 AVERAGE SKILL INDEX

Table 5.9 shows the average skill index for each subject in every track. According to Table 5.9, it can be summarized that only two subjects are obtained HS in all tracks, which is Subject A and Subject E. Two subjects are also obtained HS in any four tracks (Subject M and Subject P). However, for HS in any three and two tracks, there are seven subjects each. Finally, there is one subject obtained HS in just one track, which is Subject S. However, only Subject B is MS in all tracks.

From Table 5.9 also, it can be concluded that the easiest track is circular track because the number of HS is the highest, which is 17 subjects. On the other hand, the hardest track is triangle-shaped track because only two HS subjects in this track. Interestingly, straight track is considered as the second hardest track because there are only eight HS subjects compared to the number of HS subjects in other two tracks. Thus, in general, H6 is not supported from this experiment.

Table 5.9: Average skill index for each subject in every track.

Subject	Straight		Circular		Elliptical		Square		Triangular	
	J	Class	J	Class	J	Class	J	Class	J	Class
A	0.74	HS	0.74	HS	0.76	HS	0.67	HS	0.65	HS
B	0.60	MS	0.55	MS	0.58	MS	0.60	MS	0.54	MS
C	0.53	MS	0.65	HS	0.70	HS	0.62	MS	0.54	MS
D	0.60	MS	0.74	HS	0.62	MS	0.64	HS	0.57	MS
E	0.69	HS	0.72	HS	0.73	HS	0.66	HS	0.65	HS
F	0.66	HS	0.66	HS	0.62	MS	0.68	HS	0.58	MS
G	0.68	HS	0.72	HS	0.71	HS	0.59	MS	0.52	MS
H	0.58	MS	0.76	HS	0.61	MS	0.65	HS	0.60	MS
I	0.64	HS	0.63	HS	0.61	MS	0.65	HS	0.53	MS
J	0.58	MS	0.73	HS	0.67	HS	0.65	HS	0.61	MS
K	0.63	HS	0.61	MS	0.65	HS	0.63	HS	0.58	MS
L	0.54	MS	0.69	HS	0.65	HS	0.57	MS	0.47	MS
M	0.67	HS	0.69	HS	0.66	HS	0.65	HS	0.60	MS
N	0.59	MS	0.74	HS	0.65	HS	0.61	MS	0.55	MS
O	0.60	MS	0.67	HS	0.64	HS	0.64	HS	0.56	MS
P	0.68	HS	0.68	HS	0.68	HS	0.67	HS	0.61	MS
Q	0.63	HS	0.60	MS	0.63	HS	0.59	MS	0.53	MS
R	0.54	MS	0.70	HS	0.65	HS	0.62	MS	0.53	MS
S	0.60	MS	0.68	HS	0.61	MS	0.61	MS	0.51	MS
T	0.62	MS	0.72	HS	0.70	HS	0.64	HS	0.62	MS
Average	0.62	MS	0.68	HS	0.66	HS	0.63	HS	0.57	MS

5.8.5 OVERALL SKILL INDEX AND EXPERIENCE

Table 5.10 shows the overall skill index, and number of years of driving and gaming experience, as well as the hypothesis H7 validation for each subject. It can be summarized that 11 subjects are HS in this experiment, which is involved the expected and guided conditions. The highest value of skill index, which is 0.71, is

obtained by Subject A. On the other hand, the lowest value of skill index, which is 0.58, is obtained by Subject B. These values and classes of skill index are used as a standard level for every subject and will be compared in selected unexpected conditions as explained in Chapter 6.

Table 5.10: Hypothesis H7 validation for each subject.

Subject	Skill index, <i>J</i>	Class	DE	GE	H7 supported
A	0.71	HS	10	1	Yes
B	0.58	MS	2	1	Yes
C	0.61	MS	0	0	Yes
D	0.63	HS	23	0	Yes
E	0.69	HS	6	8	Yes
F	0.64	HS	20	0	Yes
G	0.65	HS	10	5	Yes
H	0.64	HS	7	0	Yes
I	0.61	MS	9	6	No
J	0.65	HS	15	3	Yes
K	0.62	MS	6	1	No
L	0.59	MS	10	0	No
M	0.66	HS	13	4	Yes
N	0.63	HS	8	2	Yes
O	0.62	MS	12	4	No
P	0.66	HS	15	0	Yes
Q	0.60	MS	6	3	No
R	0.61	MS	3	0	Yes
S	0.60	MS	16	3	No
T	0.66	HS	10	5	Yes

Note: DE – Driving experience, GE – Gaming Experience

Based on Table 5.10 also, by considering five years as getting experienced either in driving or gaming, it seems that 14 out of 20 subjects are support hypothesis H7. Subject I, Subject K, Subject L, Subject O, Subject Q and Subject S are expected to obtain HS because their experience in driving is more than five years, thus their skill index does not correspond to hypothesis H7.

5.8.6 EFFECTS OF EXPERIENCES AND AGES

Table 5.11: The correlation between the skill index, the experiences and the different ages of the subjects in each track.

Track	DE	GE	Age
Straight	0.29	0.42	-0.08
Circular	0.35	0.05	0.16
Elliptical	-0.14	0.28	-0.33
Square	0.37	0.08	0.10
Triangle	0.17	0.22	-0.17

Note: **DE** – Driving Experience, **GE** – Gaming Experience

Table 5.11 shows the correlation values between the skill indices and experiences, whether driving or gaming experience. It can be summarized that the skill index in every track correlates positively with driving and gaming experiences, except for elliptical track. In other words, if the number of years of experience is increased, then the skill index is increased.

In elliptical track, the skill index correlates negatively with driving experience. It means that if the number of years of driving experience increases, then the skill index is the decreased. However, all relationship is not very significant except for straight track and gaming experience, which is moderate relationship. In other words, the experiment is unable to show an important relationship between skill index and experience. Thus, it can be considered to be a minor factor in improving the skill index in normal conditions.

Table 5.11 also shows the correlation values between the skill indices and ages of subjects in each track. It can be described that all relationship is not significant for all tracks, although two tracks are correlated positively, which are circular and square tracks. In other words, the experiment is also unable to show an important relationship between skill index and age of subject.

5.9 SUMMARY

In this chapter, the experiments to obtain the elapsed time and the tracking error from 20 human subjects in EGC are described in detail. It consists of the objectives, scope, hypotheses, the experiment features, the procedures, the results and the analysis. The experiments performed in this chapter have demonstrated that the tracking error is inversely proportional to the elapsed time in most of the tracks. Also, there is a downward trend in the elapsed time and tracking error after several trials. The skill index is also improved gradually after several trials. The analysis also shows that the experiences and ages have less effect to the driving skill in all tracks.

CHAPTER 6

STUDY OF HUMAN SKILL IN SUDDEN TRANSITORY CONDITIONS (STC)

6.1 INTRODUCTION

This chapter describes the approach to studying human driving skill in Sudden Transitory Conditions (STC). The term STC refers to unusual situations where a car has lost its dynamic due to disturbances such as a punctured tyre or a slippery road surface in bad weather. These unforeseen situations are very dangerous to drivers because the car lost its dynamic and uncontrollable.

This study is divided into four experiments. All experiments were conducted in various conditions using the same computer simulation software as for EGC. Furthermore, STC effects are produced using the force feedback capability embedded in the steering wheel. For example, when a tyre punctures, the steering wheel vibrates, making it harder to control, just as if the conditions are happening in a real situation. The aims, objectives, scope and fundamental hypotheses of the experiment are explained in the following sections.

6.2 OBJECTIVES OF EXPERIMENTS

The main aim of this study is to understand human control actions in unexpected and unguided tracks. In this context, the term ‘unexpected’ refers to sudden conditions such as tyre punctures and slippery road surfaces, whereas ‘unguided’ refers to the circumstances when a car is out of track and there are no specific guidelines provided during STC.

Four experiments were conducted based on features of STC. Details of each STC are presented in Section 6.5. The overall objectives of the experiments are:

- a) To find the tracking error and elapsed time in various unexpected and unguided conditions.
- b) To measure the skill index of each subject in STC based on a proposed linear equation.
- c) To identify the learning skill for each human subject in five trials.

6.3 SCOPE OF EXPERIMENTS

The experiments are designed to measure several aspects of human-machine interaction during STC. Similar to EGC, the input devices in these experiments are a steering wheel with pedals. By using these devices, the actual effects of STC are mimicked. For instance, in the event of a tyre puncture, the steering wheel vibrates and becomes difficult to control.

These experiments used the same human subjects involved in EGC. Therefore, comparisons can be made between EGC and STC for each subject in terms of skill index and effects. Moreover, tracking error is measured from the start until the end of each track. In other words, the error is not only measured when STC occurs but on all parts of the track.

The simulation was conducted selectively on three tracks. The tracks are (1) a straight track, (2) an ellipsoid route and (3) a square route. Track (1) is a track without cornering effects and was used for STC1 and STC2. Track (2) and Track (3) have corners and were used for STC3 and STC4, respectively.

These experiments only considered two examples of unexpected effects. These effects are tyre puncture and a slippery road surface. The selection of these effects is based on the problem statement given in Chapter 1.2. It is shown that humans cannot respond to changes that are too sudden. Accidents are inevitable even if a human anticipates them and is well prepared.

Each effect has different features. Tyre puncture occurs at a fixed point on the track for each trial. This effect continues until the end of the track or when the car has stopped completely. However, the slippery surface test occurs once at a random point for each trial. Moreover, this effect has two different durations, short (for two seconds) or medium (for five seconds). When it is over, the car is returned to normal conditions and no effect is applied. Other aspects such as feedback, car transmission, top speed and the gender of the human subjects are similar to those in EGC, as explained in Chapter 5.3.

6.4 HYPOTHESES

Before the experiments are conducted, the following hypotheses are outlined.

H (A) Tracking error in STC is directly proportional to elapsed time.

H (B) Elapsed time and tracking error are expected to decrease after several trials for a fixed location puncture.

H (C) Elapsed time and tracking error are also expected to decrease when the random location of the slippery surface is toward the end of the track.

H (D) A higher tracking error is expected during a tyre puncture.

H (E) A higher tracking error is also expected for STC tracks with bends and corners.

H (F) A higher tracking error is also expected for long stretches of slippery surface.

H (G) For effects at fixed locations, human skill is expected to improve gradually after several trials.

H (H) For effects at random locations, human skill is inconsistent.

H (I) Human skill for dealing with tyre puncture is worse than slippery surface.

H (J) Human skill in STC is expected to be worse than EGC.

H (K) Experienced drivers or experienced gamers are expected to have medium skills in STC.

6.5 EXPERIMENT FEATURES

Table 6.1: The features of each STC experiments

Experiment	Effects	Track	Fixed/Random	Start (s)	Duration (s)
STC1	<ul style="list-style-type: none"> • Tyre puncture 	Straight	Fixed	5	Until end
STC2	<ul style="list-style-type: none"> • Slippery surface 	Straight	Random	Trial 1 - 2 Trial 2 - 2 Trial 3 - 5 Trial 4 - 5 Trial 5 - 8	2 5 2 5 2
STC3	<ul style="list-style-type: none"> • Tyre puncture • Cornering 	Elliptical	Fixed	10	Until end
STC4	<ul style="list-style-type: none"> • Slippery surface • Cornering 	Square	Random	Trial 1 - 5 Trial 2 - 5 Trial 3 - 10 Trial 4 - 10 Trial 5 - 15	2 5 2 5 5

Each experiment has different features and effects. The details of each experiment are shown in Table 6.1. STC1 and STC2 used a straight track, while STC3 and STC4 utilized ellipsoid and square tracks respectively. Furthermore, STC1 and STC3 had fixed location effects, while STC2 and STC4 adopted random place effects.

6.6 PROCEDURES

Figure 6.1 shows the flowchart of the experimental procedure for each human subject. Before conducting the experiment, the human subjects were briefed on the experimental procedures. Similar to EGC, the subjects were given 30 seconds to become familiarised with the steering wheel feedback before the start of the real trial. After the initial familiarisation period, the experiment was conducted in the following sequence:

1. STC1.
2. STC2.
3. STC3.
4. STC4.

The human subjects were requested to follow the selected tracks as accurately as possible. When STC occurs, they were instructed to keep control of the car without stopping, even if the car was out of track, until the end of the track. There were five trials for each STC. No time limit for each trial. However, the human subjects were advised to complete the trial as fast as possible. The elapsed time and the coordinates of the car in x, z axes were recorded for analysis.

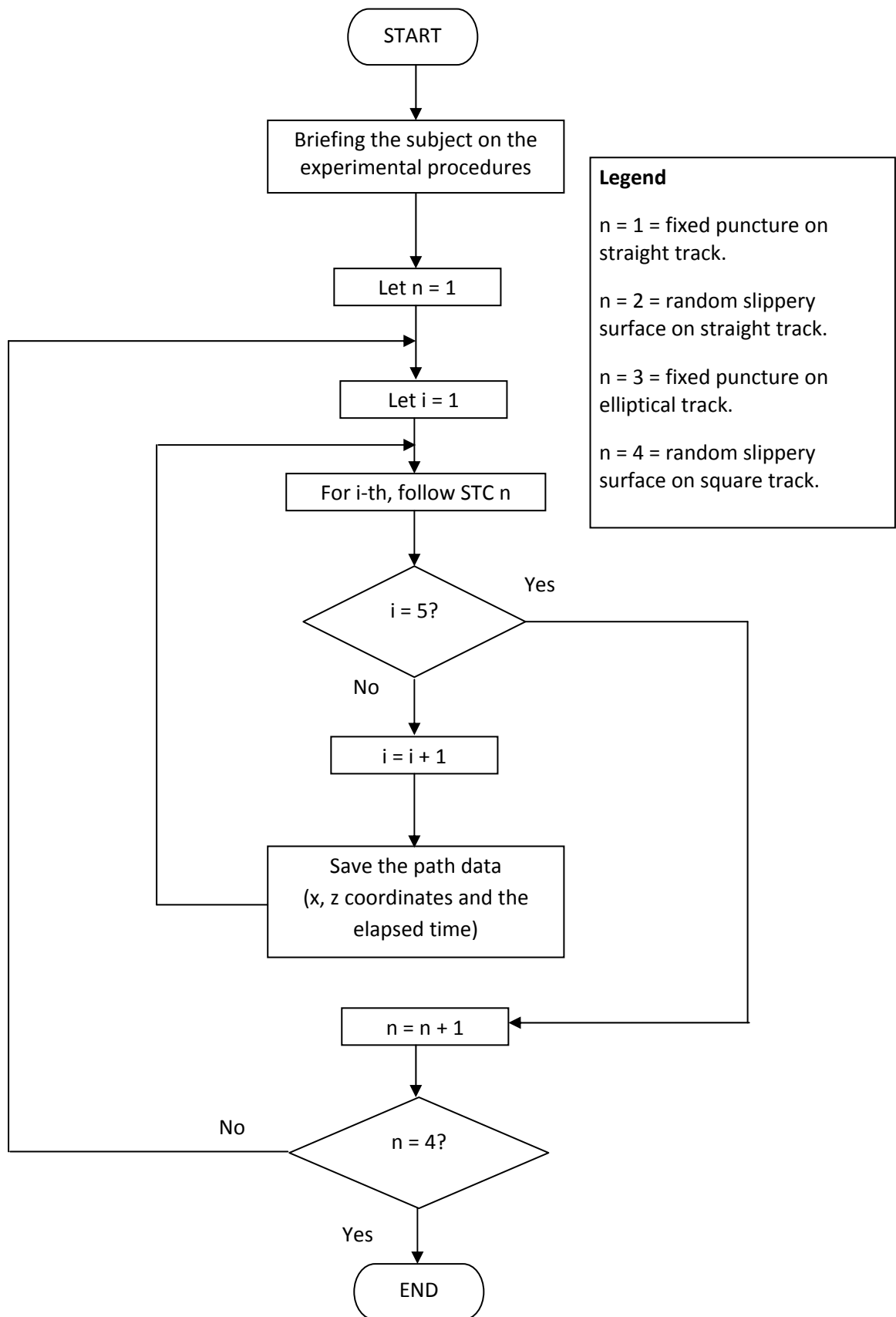

Figure 6.1: Flowchart of the experimental procedure.

6.7 RESULTS

The experimental results from 20 human subjects (Subject A to Subject T) are shown. Each human subject generated 40 combinations of data for elapsed time and tracking errors, obtained from four STC experiments. Therefore, a total of 800 data sets were generated for these experiments. Note that the line graphs shown in Figure 6.2 and Figure 6.6 are for elapsed time and the column graphs are for tracking error. Also, E1 is the tracking error in trial 1, E2 is the tracking error in trial 2, T1 is the elapsed time for trial 1 and T2 is the elapsed time in trial 2 and so on.

6.7.1 STC1: STRAIGHT TRACK WITH FIXED PUNCTURE

Figure 6.2 shows the elapsed time and tracking error in each trial for every subject from fixed tyre puncture on straight track. It can be observed that in trial 1 (Figure 6.2 (a)), Subject E is obtained the fastest time, yields the smallest error. Thus, these results are support hypothesis H (A). Other results in trial 1 show that Subject C and Subject D are obtained the largest error and the slowest time, respectively.

For trial 2 (Figure 6.2 (b)), results demonstrate that Subject E and Subject B are obtained the smallest and the largest error, respectively. On the other hand, Subject C and Subject F are obtained the fastest and the slowest time, respectively. Thus, trial 2 does not support H (A).

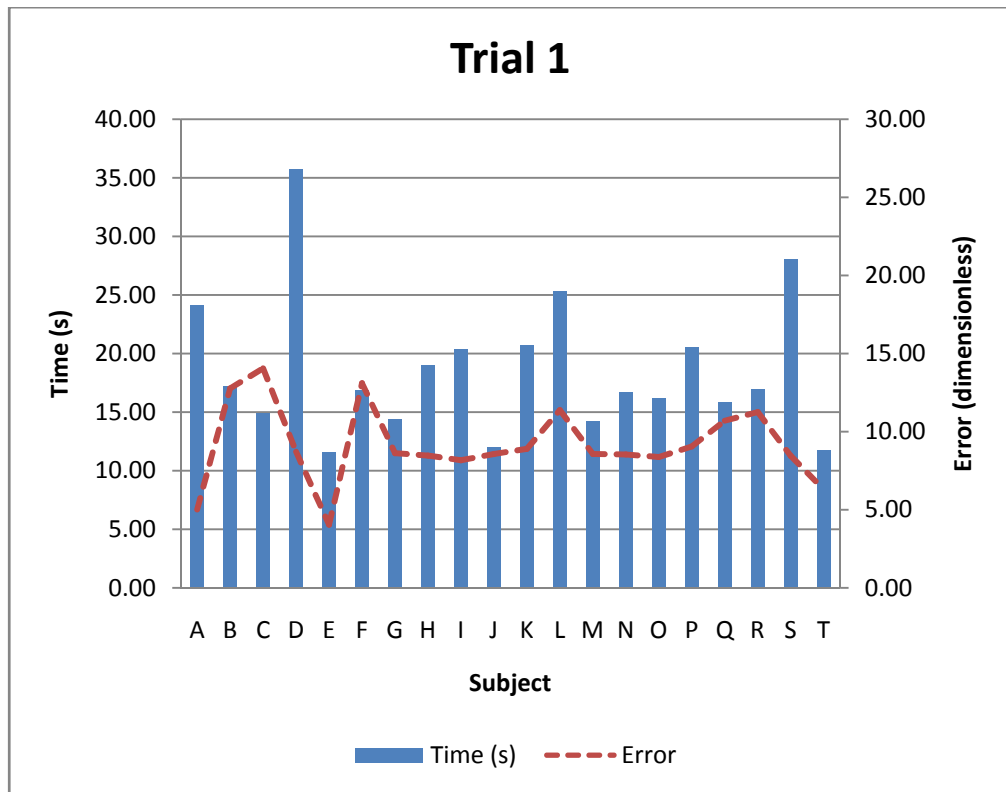

(a)

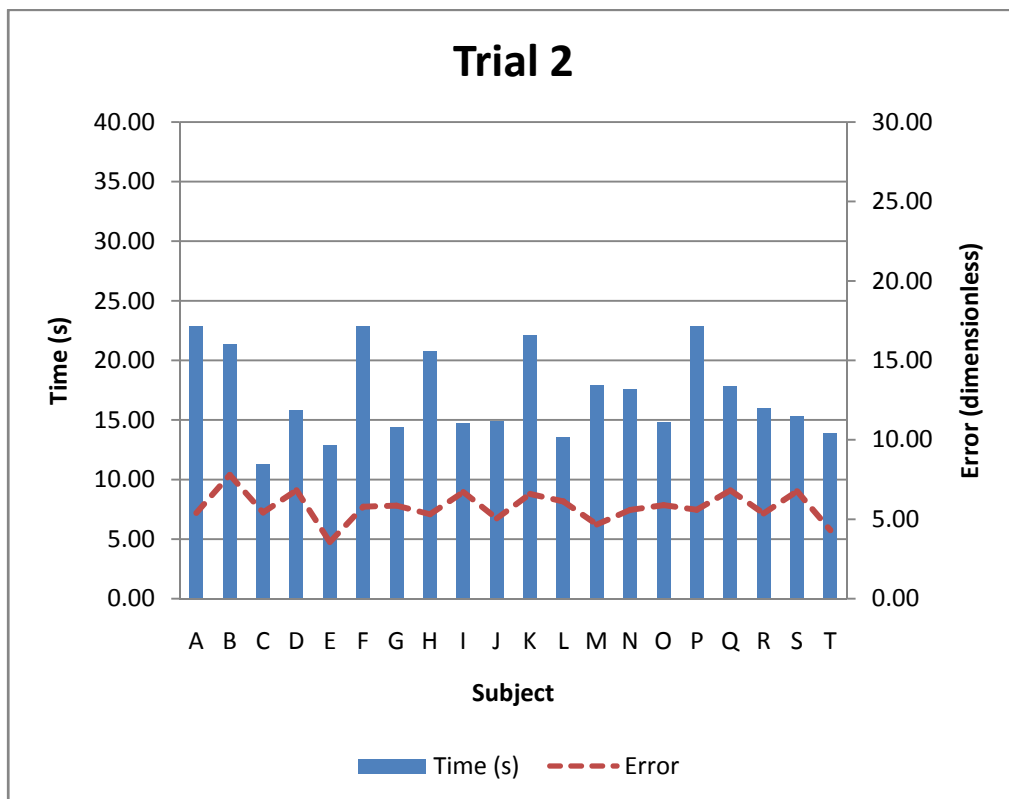

(b)

Figure 6.2: Results from STC1. Refer to Appendix 3(A) for more detail.

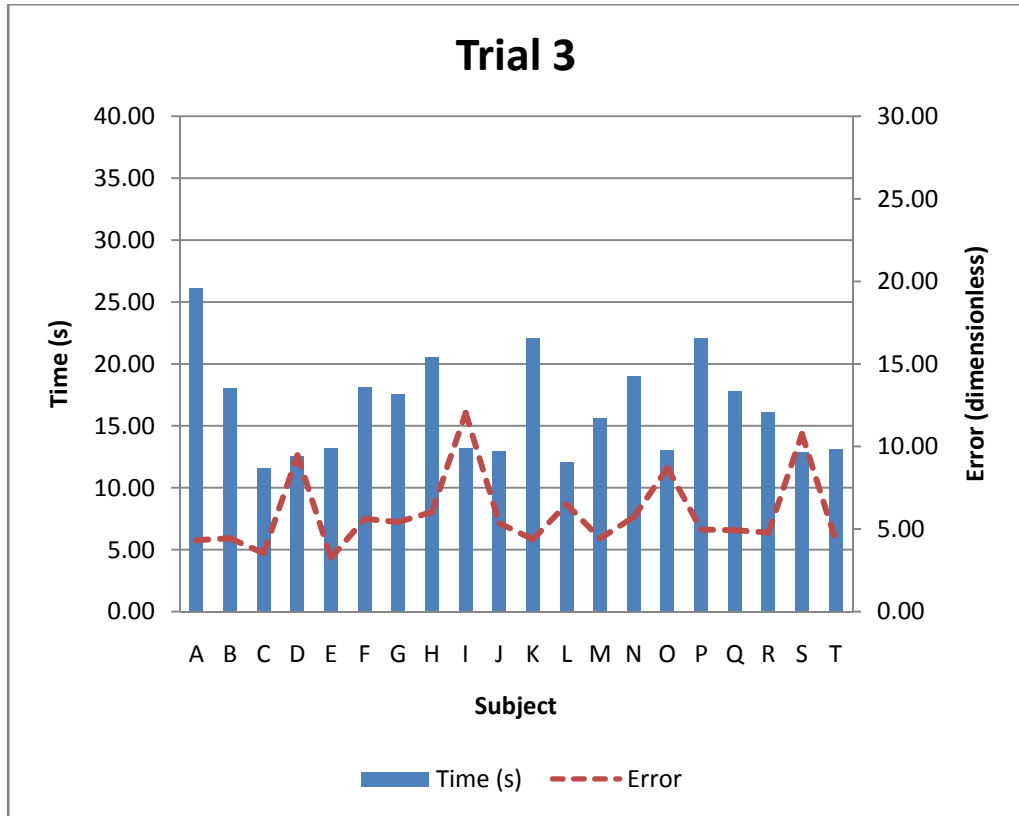

(c)

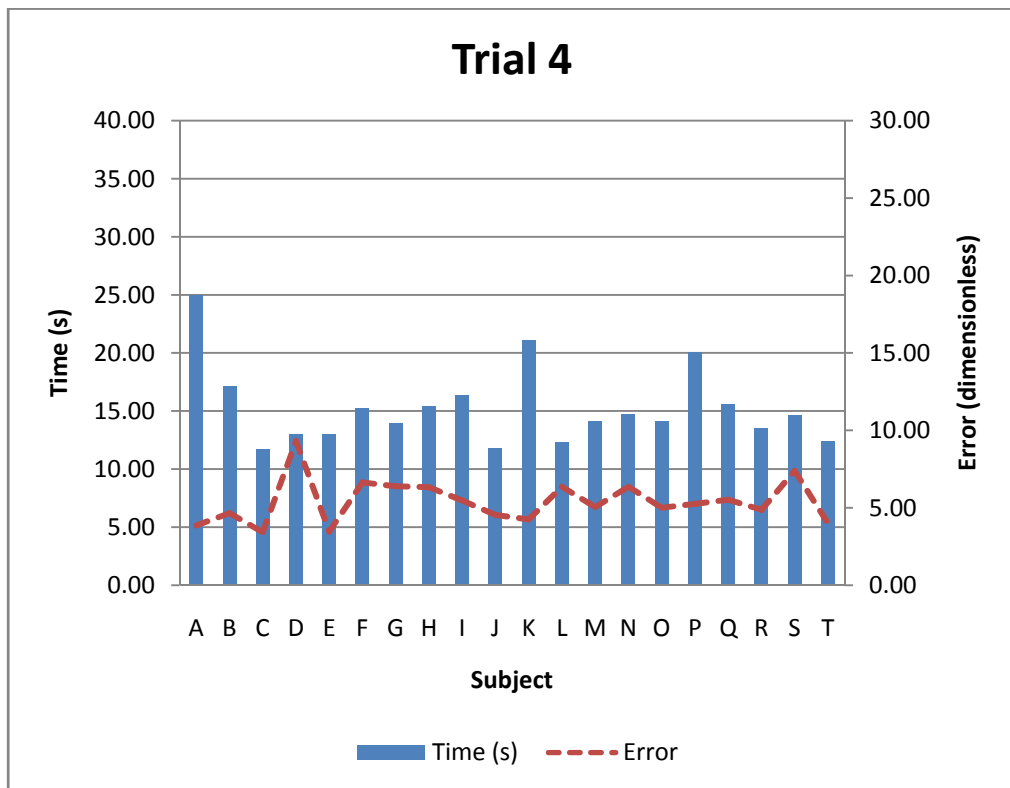

(d)

Figure 6.2: Results from STC1. Refer to Appendix 3(A) for more detail (cont.).

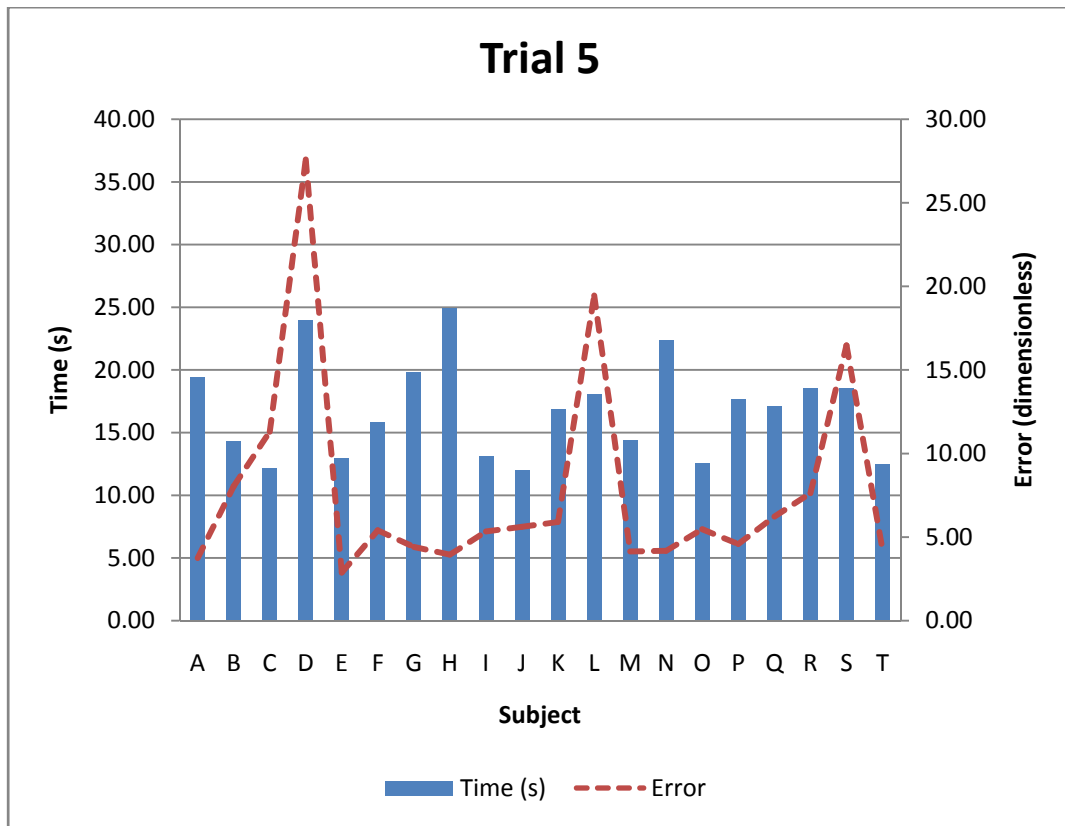

(e)

Figure 6.2: Results from STC1. Refer to Appendix 3(A) for more detail (cont.).

In trial 3 (Figure 6.2 (c)), Subject E is obtained the smallest error for third consecutive time. Other results in trial 3 show that Subject I, Subject C and Subject A are obtained the largest error, the fastest and the slowest time, respectively. Thus, trial 3 also does not support H (A).

In trial 4 (Figure 6.2 (d)), the results are corresponded to hypothesis H (A) because Subject C is obtained the fastest time with the smallest error. Other results in trial 4 show that Subject D and Subject A are obtained the largest error and the slowest time, respectively.

Lastly, results in trial 5 (Figure 6.2 (e)) show that Subject E is obtained the smallest error, Subject D (the largest error), Subject J (the fastest time) and Subject H (the slowest time). Thus, these results do not supported hypothesis H (A).

Overall results for STC1 demonstrate that hypothesis H (A) is supported in trial 1 and trial 4. Both trials show that the fastest time yields the smallest error. For average value, the results are shown in Figure 6.3. It can be observed that there is a downward trend in both average results after several trials. Thus, these results are supported hypothesis H (B).

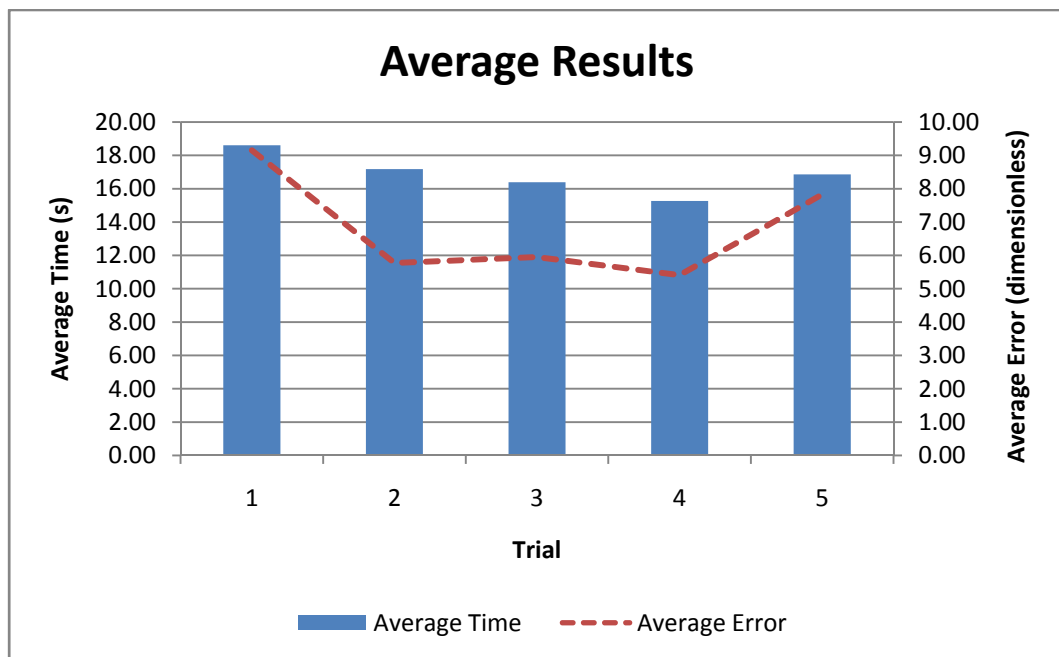

Figure 6.3: Average results for STC1 in each trial.

6.7.2 STC2: STRAIGHT TRACK WITH RANDOM SLIPPERY SURFACE

Figure 6.5 show the elapsed time and tracking error in each trial for every subject from a random slippery surface effect on straight track. For trial 1 (Figure 6.4 (a)), results show that Subject D is obtained the smallest error, Subject G (the largest error), Subject C (the fastest time) and Subject H (the slowest time). Thus, these results in trial 1 do not supported hypothesis H (A).

In trial 2 (Figure 6.5 (b)), results show that Subject F and Subject D are obtained the smallest and the largest error, respectively. On the other hand, Subject C and Subject A are obtained the fastest and the slowest time, respectively. Thus, H (A) is also unsupported.

In trial 3 (Figure 6.5 (c)), the same condition is occurred, where H (A) does not supported. Results show that the fastest time is obtained by Subject C, the slowest time (Subject F), the smallest error (Subject E and Subject M) and the largest error (Subject D).

In trial 4 (Figure 6.5 (d)), the smallest error is obtained by three subjects, which are Subject E, Subject F and Subject M. One of the subjects (Subject E) is also obtained the fastest time. Thus, these results are corresponded to hypothesis H (A). Other results in trial 4 show that Subject D and Subject F are obtained the largest error and the slowest time, respectively.

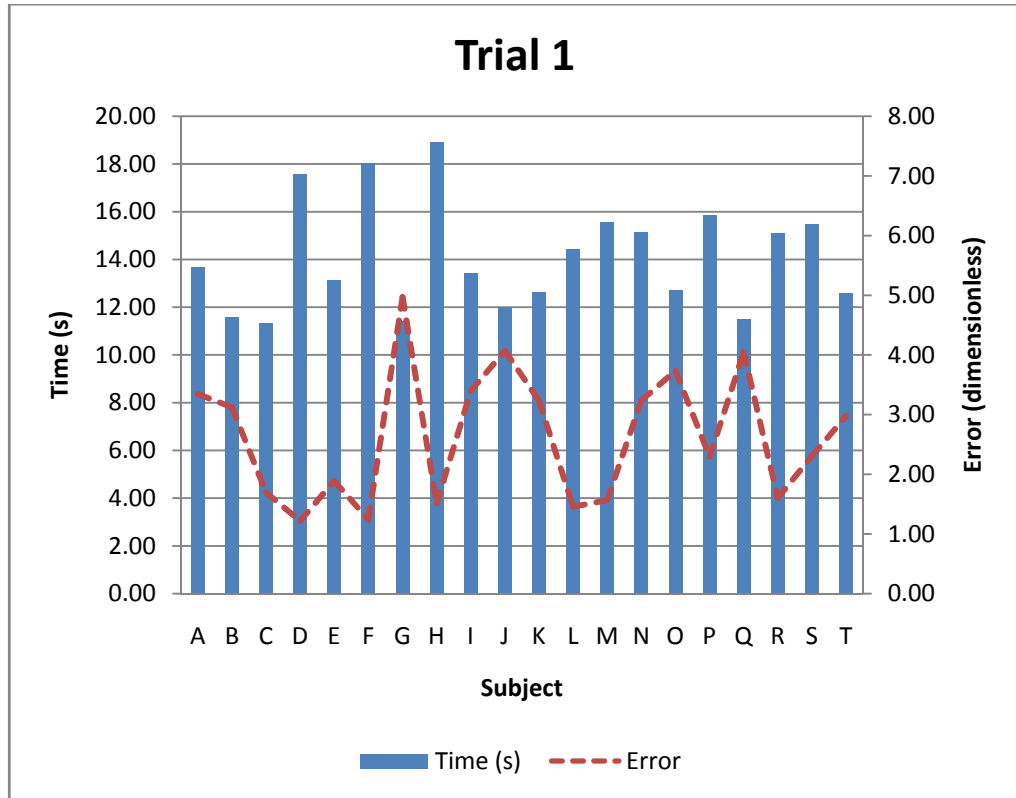

(a)

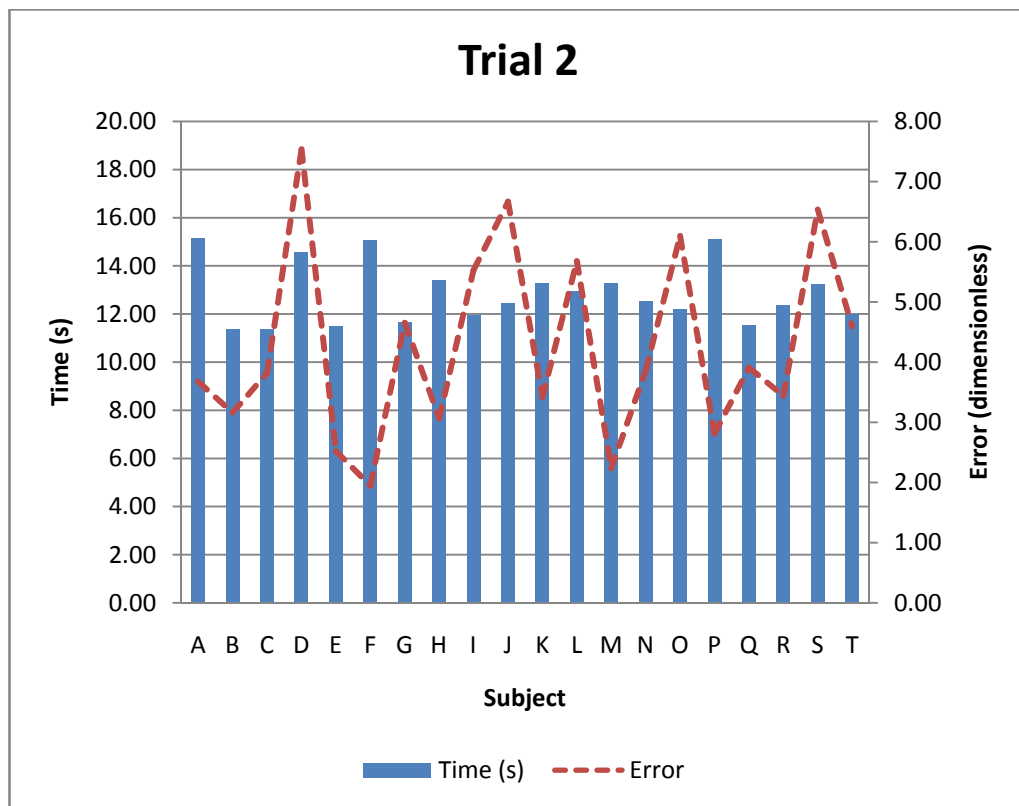

(b)

Figure 6.4: Results from STC2. Refer to Appendix 3(B) for more detail.

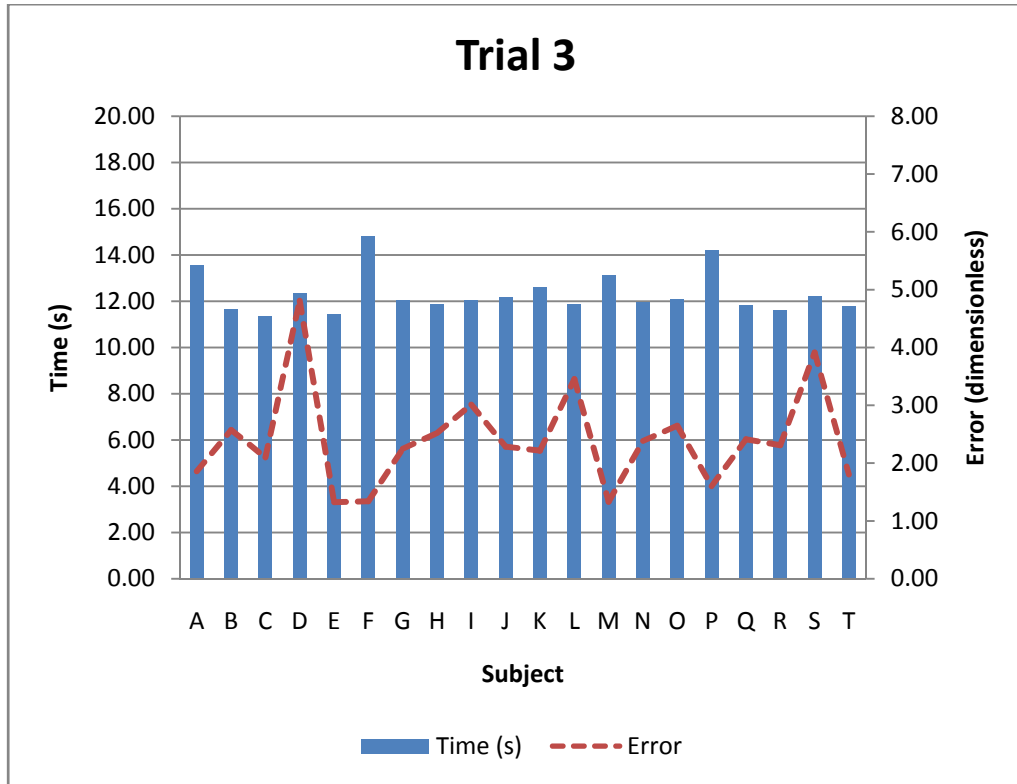

(c)

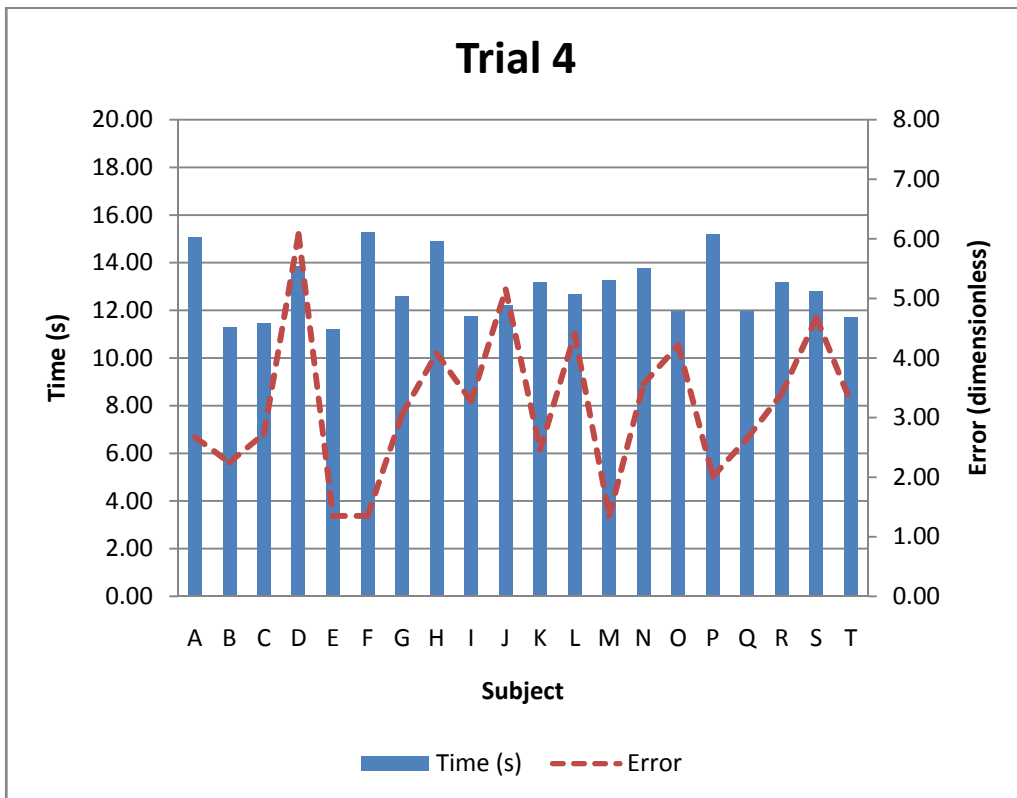

(d)

Figure 6.4: Results from STC2. Refer to Appendix 3(B) for more detail (cont.).

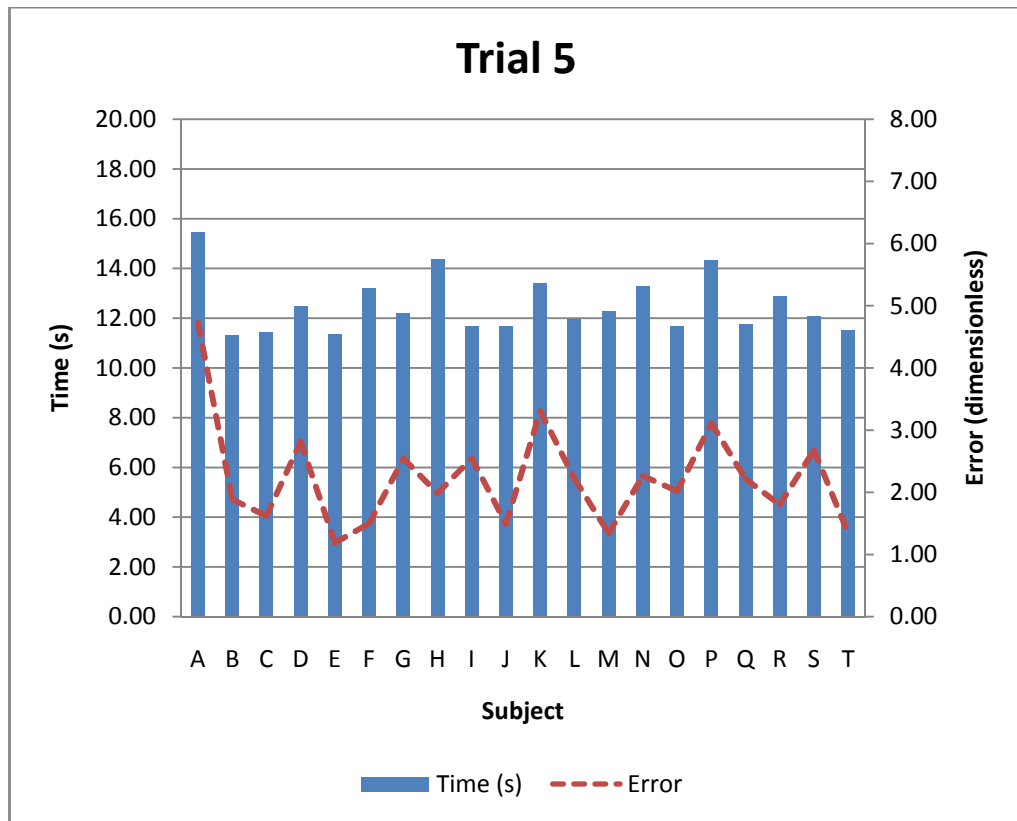

(e)

Figure 6.4: Results from STC2. Refer to Appendix 3(B) for more detail (cont.).

In trial 5 (Figure 6.4 (e)), hypothesis H (A) is also supported, since Subject A is obtained the largest error with the slowest time. Other results in trial 5 show that Subject E is obtained the smallest error and Subject B is the fastest.

For overall results in STC2, it is demonstrated that only trial 4 and trial 5 support H (A). For trial 4, the fastest time yields the smallest error, obtained by Subject E. However, for trial 5, the slowest time yields the biggest error, revealed by Subject A. Apart from that, other results do not support H (A).

Figure 6.5 shows the average time and error in each trial for STC2. Although there is a downward trend in average time, but there is a fluctuation in average error after several trials. Therefore, these results disagree with H (C).

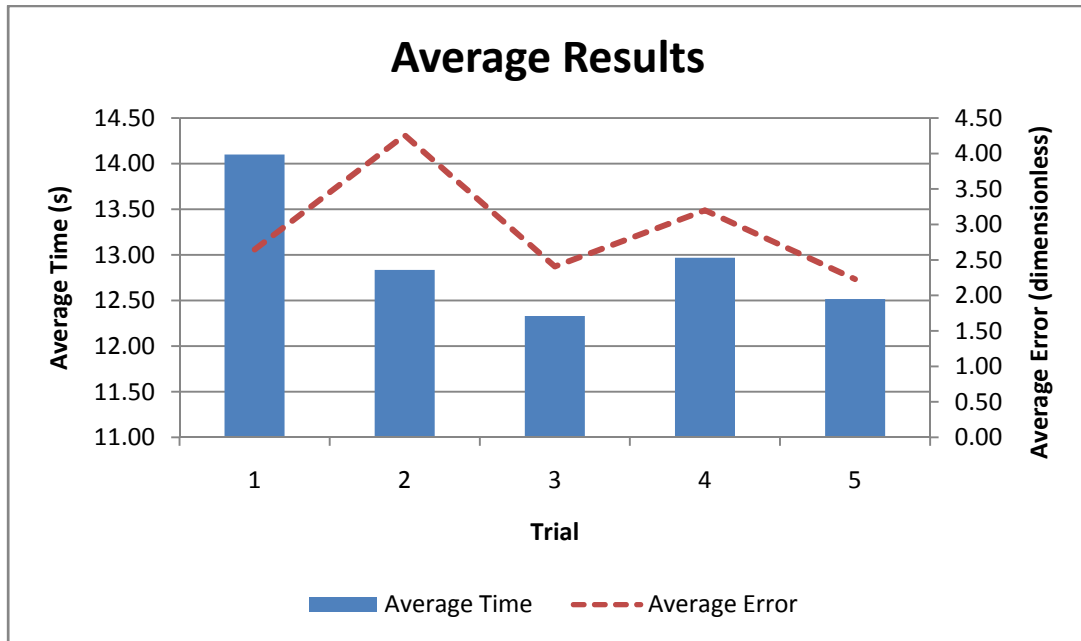
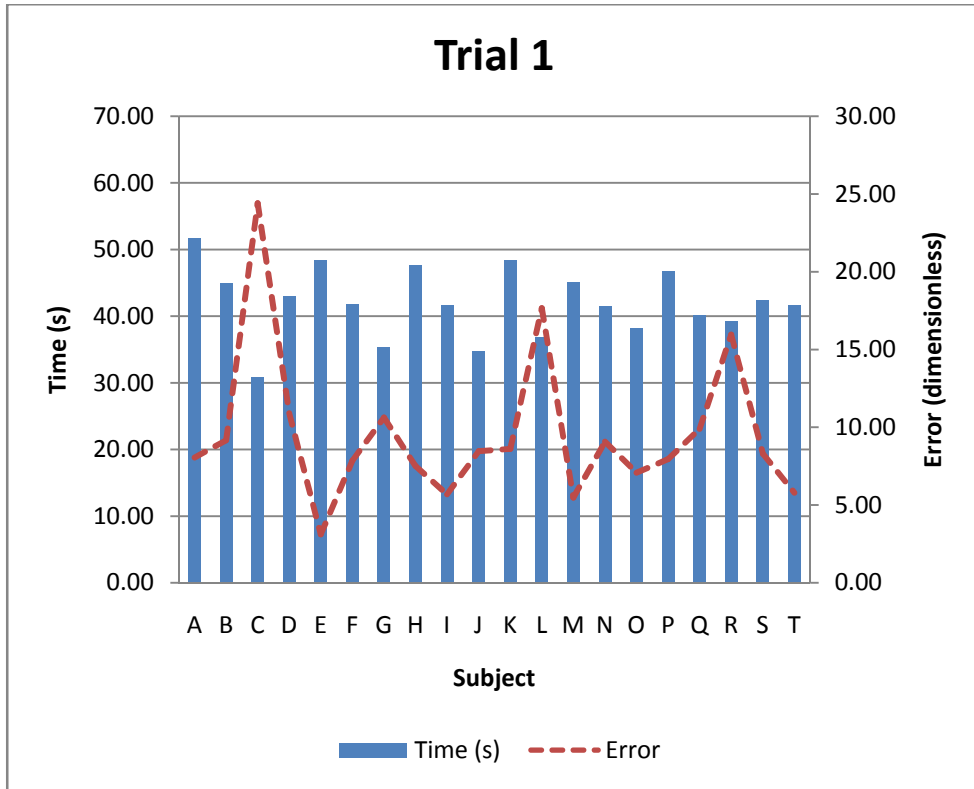

Figure 6.5: Average results for STC2 in each trial.

6.7.3 STC3: ELLIPTICAL TRACK WITH FIXED PUNCTURE

Figure 6.6 shows the results from STC3 for every subject in each trial. It can be observed that in trial 1 (Figure 6.6 (a)), although Subject C is obtained the largest error with the fastest time, these results disagree with hypothesis H (A). Other results indicate that Subject E and Subject C are obtained the smallest and the largest error, respectively.



(a)

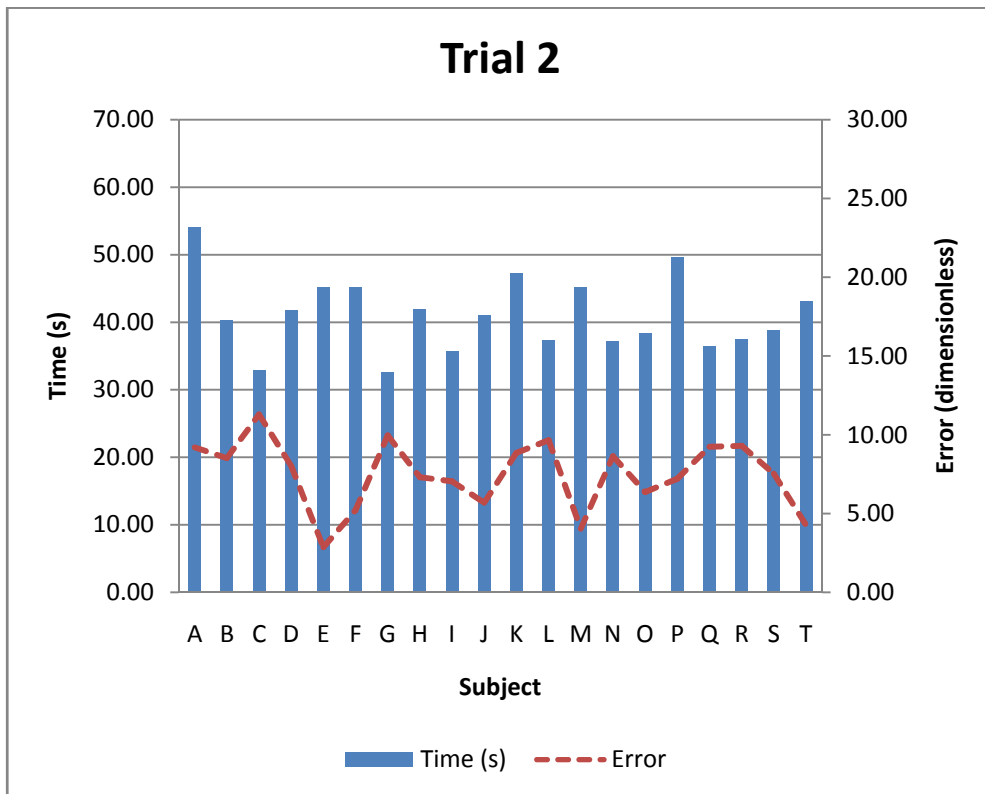

(b)

Figure 6.6: Results from STC3. Refer to Appendix 3(C) for more detail.

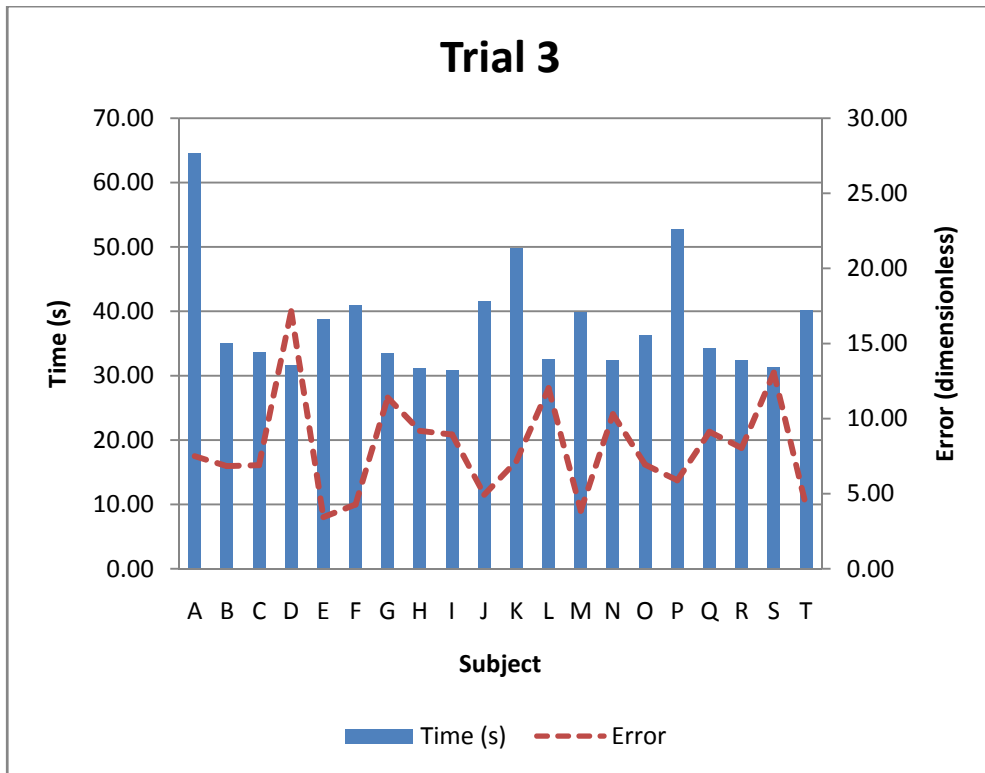

(c)

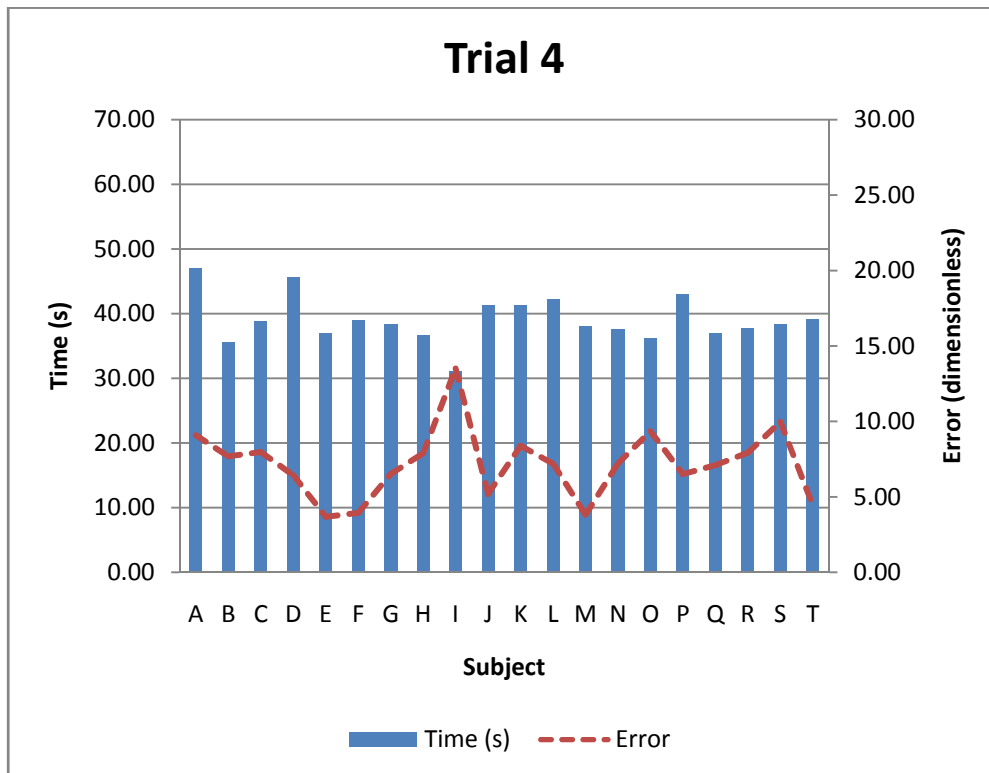

(d)

Figure 6.6: Results from STC3. Refer to Appendix 3(C) for more detail (cont.).

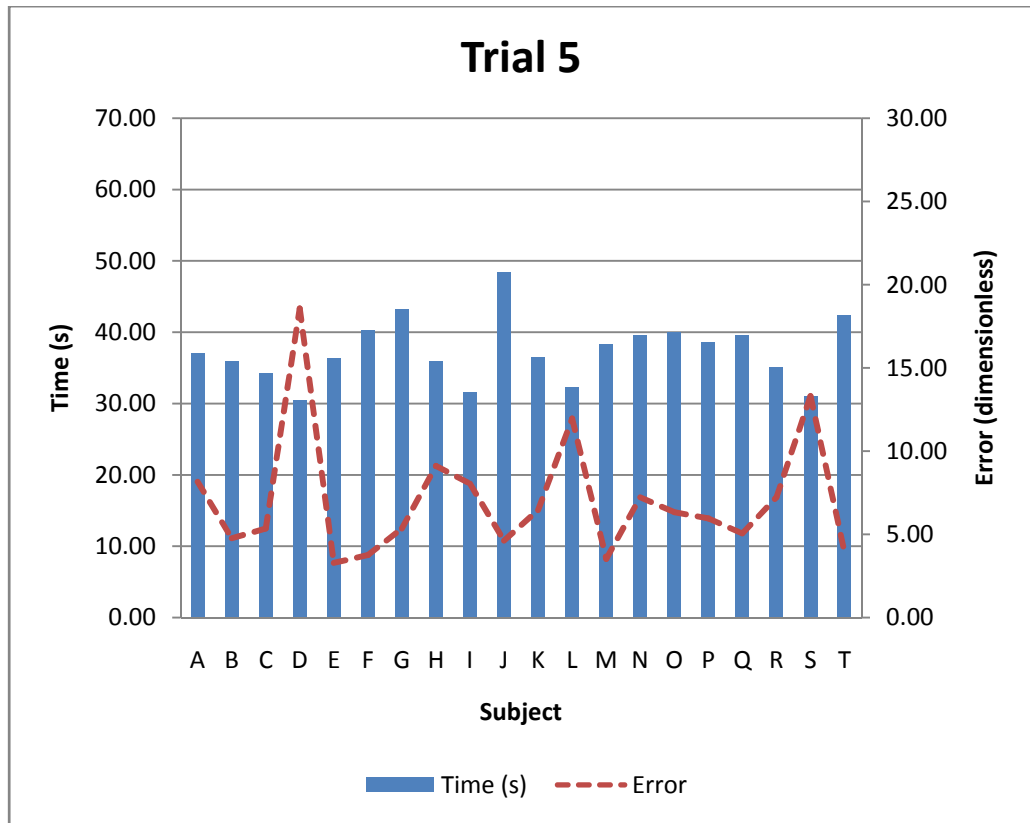

(e)

Figure 6.6: Results from STC3. Refer to Appendix 3(C) for more detail (cont.).

In trial 2 (Figure 6.6 (b)), the smallest error, the largest error and the slowest time are obtained by the same subject as previous trial, which are Subject E, Subject C and Subject A, respectively. Furthermore, Subject G is obtained the fastest time. Thus, these results also disagree with H (A).

In trial 3 (Figure 6.6 (c)), Subject E and Subject A are obtained the smallest error and the slowest time, respectively, for third consecutive time. Other results show that Subject D is obtained the largest error, and Subject I is the fastest. Thus, H (A) is still unsupported in this trial.

In trial 4 (Figure 6.6 (d)), Subject I is obtained the largest error with the fastest time. However, these results do not correspond to hypothesis H (A). Other results in trial 4 indicate that Subject E and Subject A are obtained the smallest error and the slowest time, respectively, for fourth consecutive time.

In trial 5 (Figure 6.6 (e)), although Subject D is obtained the largest error with the fastest time, these results still disagree with hypothesis H (A). Other results in trial 5 show that Subject E is obtained the smallest error for fifth consecutive time and Subject J is the slowest.

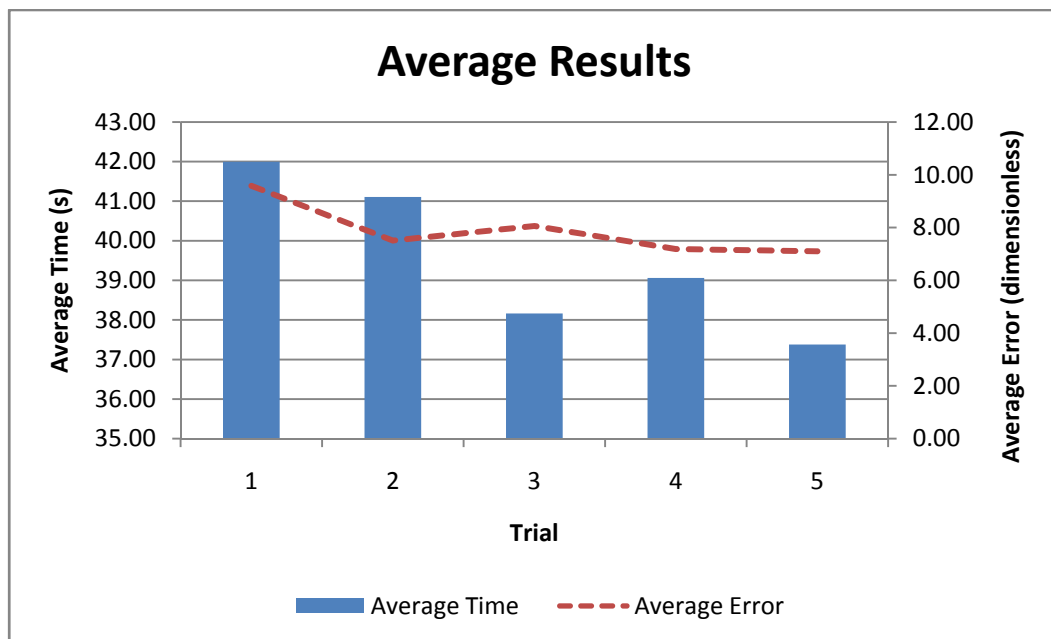

Figure 6.7: Average results for STC3 in each trial.

Overall results from STC3 indicate that hypothesis H (A) does not supported in any trial. No sign shows that the tracking error is directly proportional to elapsed time in

STC3. However, the smallest error is obtainable by the same subject in all five trials, which is Subject E.

Figure 6.7 shows the average time and error in each trial for STC3. Although hypothesis H (A) is unsupported in all trials, but there is a downward trend in both average results. Thus, hypothesis H (B) is supported.

6.7.4 STC4: SQUARE TRACK WITH RANDOM SLIPPERY SURFACE

Figure 6.8 shows the elapsed time and tracking error in each trial for every subject from a random slippery surface effect on square track. In trial 1 (Figure 6.8 (a)), it can be observed that Subject J is obtained the smallest error, Subject H (the largest error), Subject E (the fastest time) and Subject F (the slowest time). Thus, these results in trial 1 do not corresponded to hypothesis H (A).

In trial 2 (Figure 6.8 (b)), the smallest error is obtained by Subject F, the largest error (Subject G), the fastest time (Subject I) and the slowest time (Subject D). Thus, the results in trial 2 also do not support the hypothesis H (A).

Although Subject I is obtained the largest error with the fastest time in trial 3 (Figure 6.8 (c)), these results are still disagreed with hypothesis H (A). Other results in trial 3 indicate that Subject A and Subject F are obtained the smallest error and the slowest time, respectively.

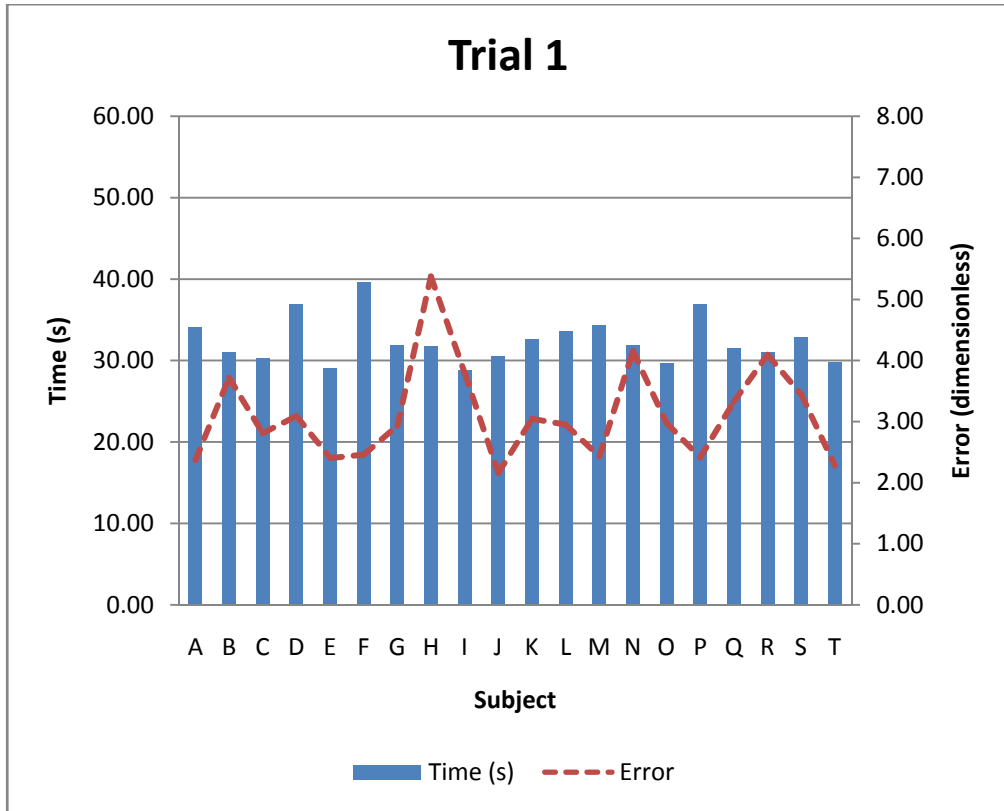

(a)

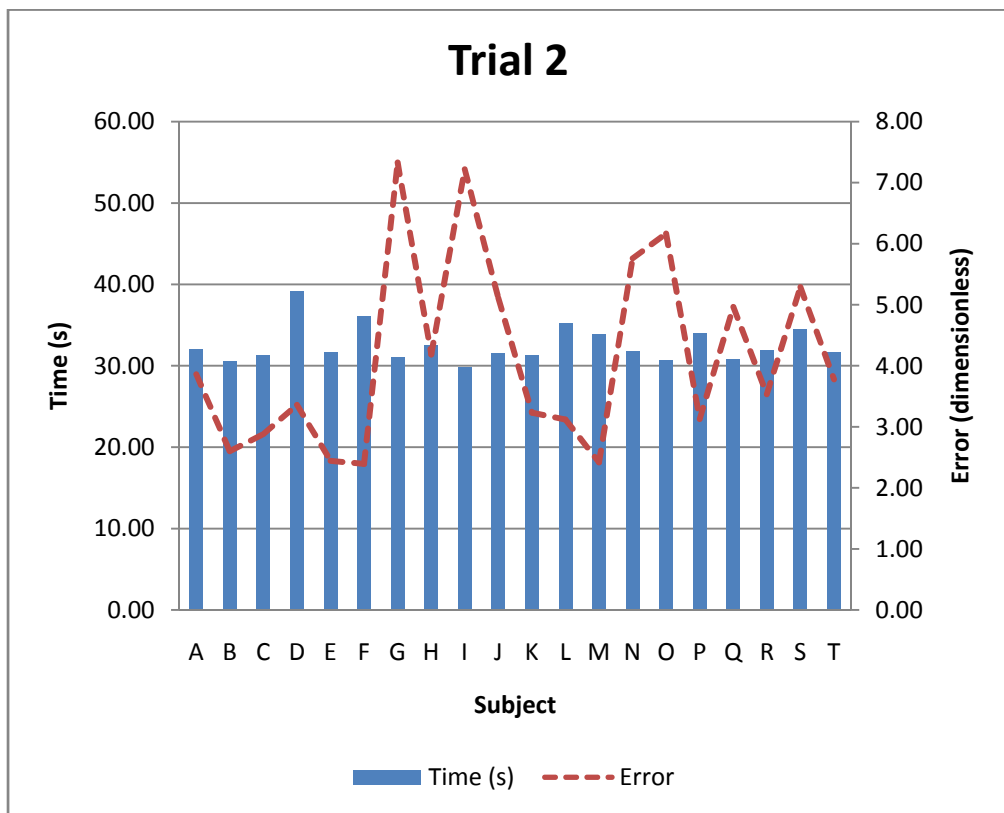

(b)

Figure 6.8: Results from STC4. Refer to Appendix 3(D) for more detail.

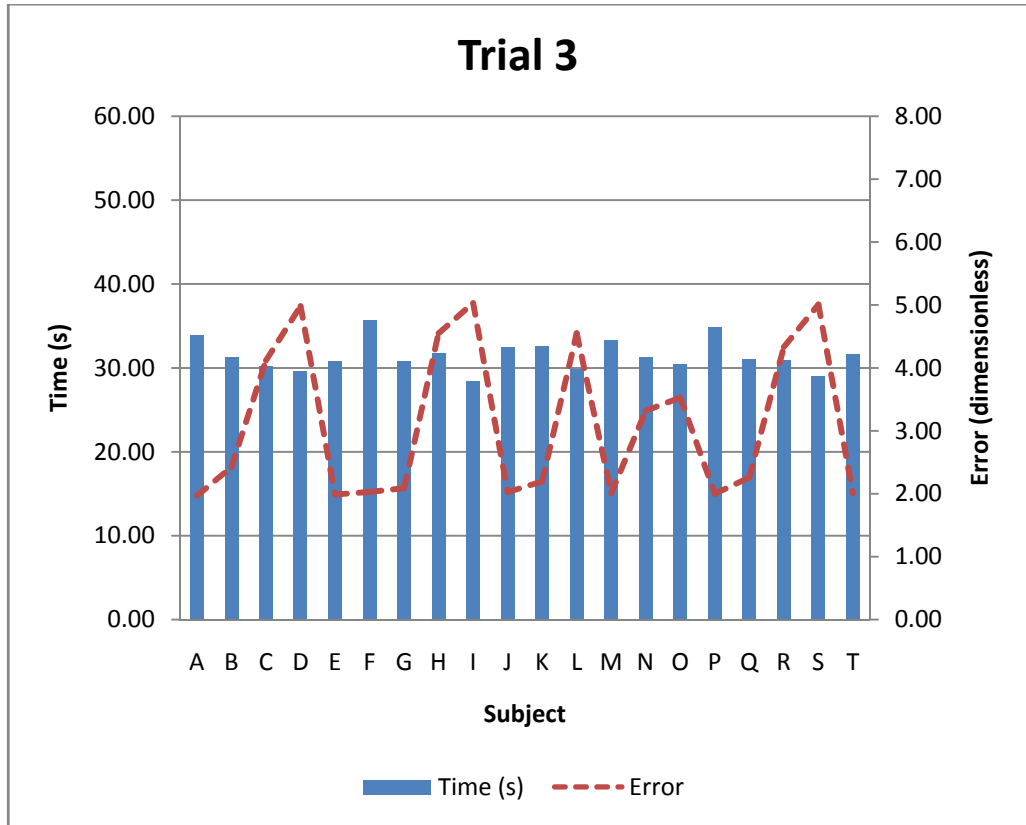

(c)

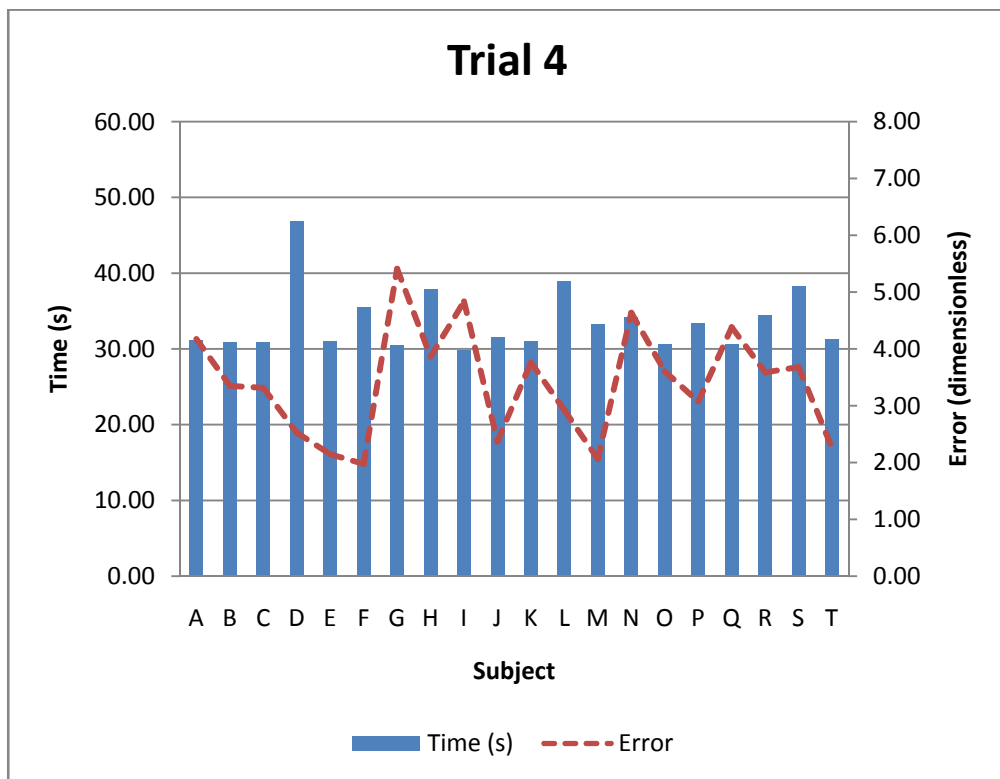

(d)

Figure 6.8: Results from STC4. Refer to Appendix 3(D) for more detail (cont.).

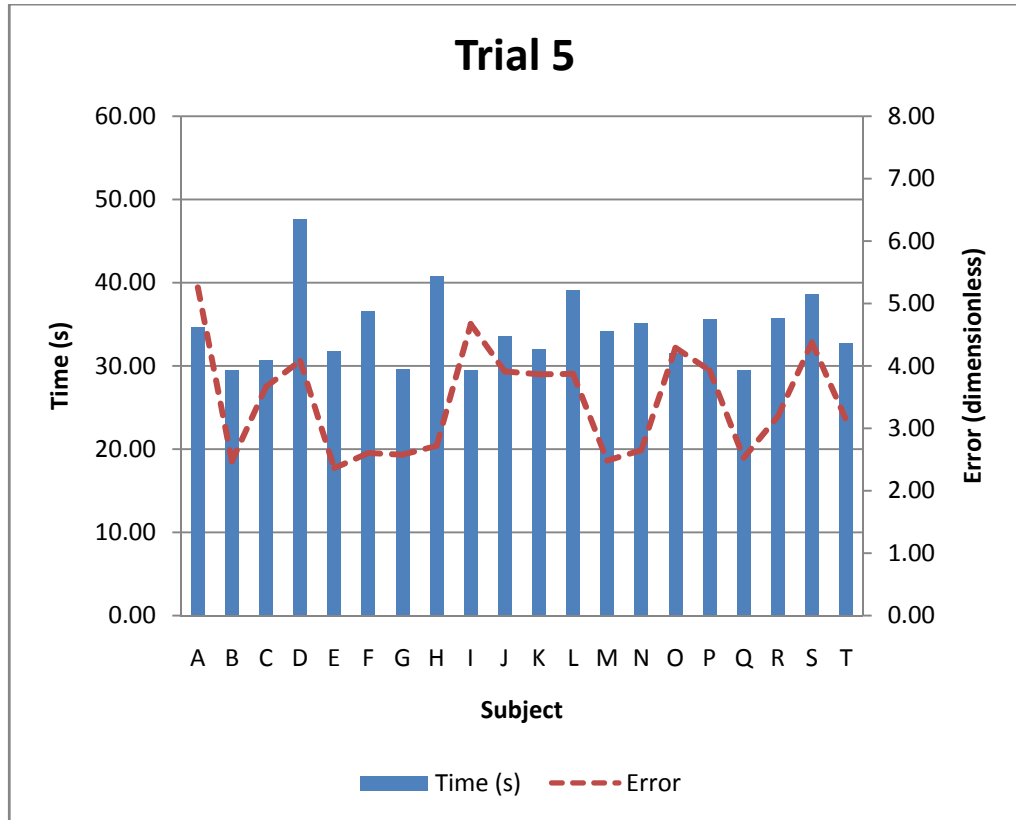

(e)

Figure 6.8: Results from STC4. Refer to Appendix 3(D) for more detail (cont.).

In trial 4 (Figure 6.8 (d)), Subject F and Subject G are obtained the smallest and the largest error, respectively. In contrast, Subject B and Subject D are obtained the fastest and the slowest time, respectively. Thus, these results also do not support hypothesis H (A).

Lastly, in trial 5 (Figure 6.8 (e)), the same conditions occurred as previous trials. The hypothesis H (A) still do not supported. Results in trial 5 demonstrate that the smallest error is obtained by Subject E, the largest error (Subject A), the fastest time (Subject B) and the slowest time (Subject D).

Overall results from STC4 indicate that the hypothesis H (A) is unsupported in all trials. No sign shows that the tracking error is directly proportional to elapsed time in STC4.

Figure 6.9 shows the average results in each trial for STC4. It can be observed that there is an upward trend in both average results after several trials. Therefore, these results do not support H (C).

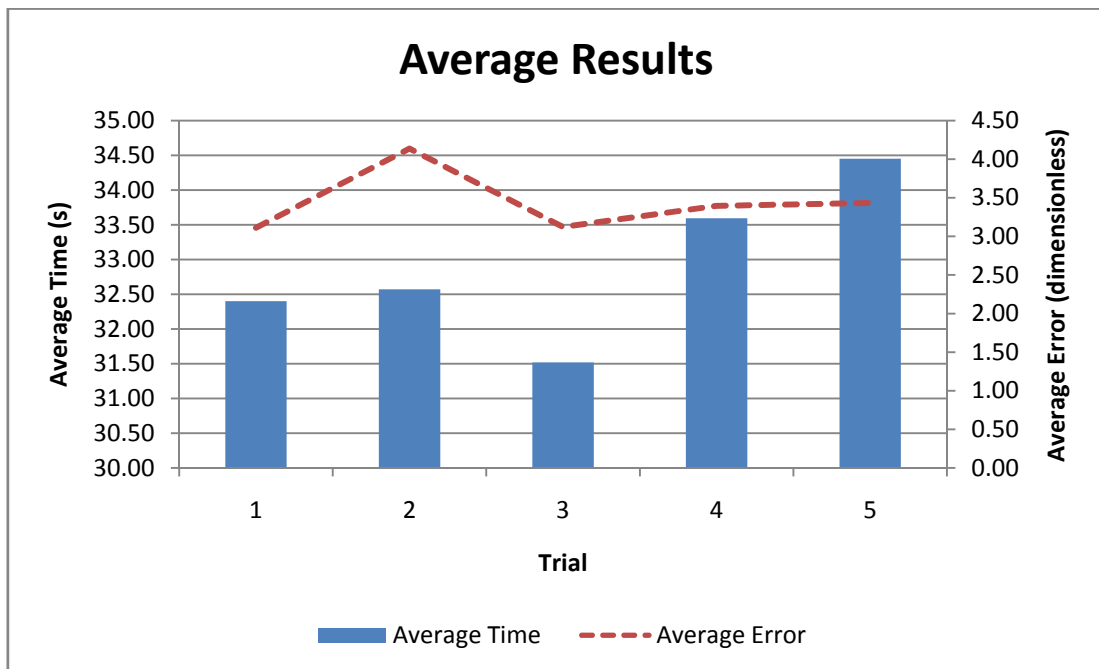

Figure 6.9: Average results for STC4 in each trial.

6.8 ANALYSIS

6.8.1 ERROR ANALYSIS

Table 6.2 shows the value of average error in every trial for each STC. It can be observed that the average errors for STC1 and STC3 in all trials are higher than the average errors for STC2 and STC4. STC1 and STC3 are using tyre puncture as an unexpected situation, thus the results are correspond to hypothesis H (D).

Table 6.2: Average error for each STC.

Trial	Average Error (dimensionless)			
	STC1	STC2	STC3	STC4
1	9.15	2.65	9.58	3.11
2	5.77	<u>4.26</u>	7.51	<u>4.14</u>
3	5.95	2.41	8.06	3.12
4	5.41	<u>3.20</u>	7.19	<u>3.40</u>
5	7.83	2.23	7.10	<u>3.43</u>

Table 6.2 also indicates that the average errors from STC3 and STC4 are higher than the average errors from STC1 and STC2, except in trial 2 from STC4 and trial 5 from STC3. As explained in Section 6.5, STC3 and STC4 are using the elliptical and square tracks, respectively, whereas, STC1 and STC2 are using straight track. Therefore, the hypothesis H (E) is also supported in all trials, except in trial 2 between STC2 and STC4; and trial 5 between STC1 and STC3. In trial 2, the average error from STC4 is lower than the average error from STC2. Also, in trial 5, the average error from STC3 is lower than the average error from STC1.

In order to validate the hypothesis H (F), only STC2 and STC4 are considered because these STCs involved the slippery surface. By considering long stretch occurred for 5 seconds, this effect can be found in trial 2 and trial 4 from STC2; and trial 2, trial 4 and trial 5 from STC4. To highlight these trials, the value of average errors are underlined and bolded in Table 6.2. It clearly shows that the underlined and bolded average errors are higher than the average errors in other trials from the same STC. Thus, the hypothesis H (F) is also supported.

6.8.2 SKILL INDEX

Based on the proposed formula in Chapter 4, the skill index of each subject in every STC is measured and is shown in Table 6.3, Table 6.4, Table 6.5 and Table 6.6. For normalized data of elapsed time and tracking error, please refer to Appendix 4.

Based on Table 6.3, it seems that most subjects are LS when driving through a straight track with a tyre puncture. Although the effect is at the same location for every trial, the human skills are still at a similar level after several trials. It means that there is no learned skill applied when the subjects deal with a tyre puncture. Only one subject achieved MS in three trials, two subjects in two trials and one subject in one trial. Other subjects are LS in every trial. Thus, these results do not agree with H (G). In other words, it shows that a tyre puncture is difficult to handle even when driving on a straight track.

Table 6.3: Skill index for STC1.

Subject	Skill index, J					Class				
	1	2	3	4	5	1	2	3	4	5
A	0.21	0.21	0.20	0.21	0.26	LS	LS	LS	LS	LS
B	0.25	0.22	0.27	0.28	0.31	LS	LS	LS	LS	LS
C	0.29	0.40	0.41	0.41	0.36	LS	MS	MS	MS	LS
D	0.14	0.29	0.35	0.34	0.18	LS	LS	LS	LS	LS
E	0.40	0.37	0.37	0.37	0.38	MS	LS	LS	LS	MS
F	0.26	0.21	0.26	0.30	0.29	LS	LS	LS	LS	LS
G	0.31	0.32	0.27	0.32	0.25	LS	LS	LS	LS	LS
H	0.24	0.23	0.23	0.30	0.21	LS	LS	LS	LS	LS
I	0.23	0.31	0.33	0.29	0.35	LS	LS	LS	LS	LS
J	0.37	0.31	0.35	0.39	0.38	LS	LS	LS	LS	MS
K	0.22	0.21	0.23	0.24	0.28	LS	LS	LS	LS	LS
L	0.18	0.33	0.37	0.36	0.24	LS	LS	LS	LS	LS
M	0.31	0.27	0.30	0.33	0.33	LS	LS	LS	LS	LS
N	0.27	0.27	0.25	0.31	0.23	LS	LS	LS	LS	LS
O	0.28	0.31	0.34	0.33	0.36	LS	LS	LS	LS	LS
P	0.22	0.21	0.22	0.24	0.27	LS	LS	LS	LS	LS
Q	0.28	0.26	0.27	0.30	0.27	LS	LS	LS	LS	LS
R	0.26	0.29	0.29	0.34	0.25	LS	LS	LS	LS	LS
S	0.17	0.30	0.34	0.31	0.23	LS	LS	LS	LS	LS
T	0.38	0.34	0.36	0.38	0.37	MS	LS	LS	MS	LS

However, based on Table 6.4, it is observed that most human subjects are MS for STC2. It can be shown that 11 subjects are MS in trial 1, nine in trial 2, 19 in trial 3, 11 in trial 4 and 17 in trial 5. This means that the slippery surface effect that occurs at the beginning of the track with a long duration (trial 2) is difficult to handle compared to other locations. Therefore, the human skill becomes inconsistent when the effects occurred at random locations. Thus, these results support H (H).

Table 6.4: Skill index for STC2.

Subject	Skill index					Class				
	1	2	3	4	5	1	2	3	4	5
A	0.36	0.32	0.40	0.34	0.31	LS	LS	MS	LS	LS
B	0.41	0.42	0.42	0.45	0.46	MS	MS	MS	MS	MS
C	0.47	0.41	0.45	0.43	0.47	MS	MS	MS	MS	MS
D	0.38	0.31	0.37	0.33	0.39	MS	LS	LS	LS	MS
E	0.41	0.43	0.50	0.50	0.51	MS	MS	MS	MS	MS
F	0.37	0.37	0.41	0.40	0.43	LS	LS	MS	MS	MS
G	0.40	0.39	0.42	0.39	0.41	LS	LS	MS	MS	MS
H	0.34	0.37	0.42	0.32	0.38	LS	LS	MS	LS	MS
I	0.36	0.38	0.40	0.41	0.42	LS	MS	MS	MS	MS
J	0.39	0.36	0.42	0.37	0.47	MS	LS	MS	LS	MS
K	0.38	0.36	0.41	0.39	0.36	MS	LS	MS	MS	LS
L	0.41	0.35	0.40	0.37	0.43	MS	LS	MS	LS	MS
M	0.38	0.39	0.45	0.44	0.47	MS	MS	MS	MS	MS
N	0.33	0.38	0.42	0.35	0.39	LS	MS	MS	LS	MS
O	0.37	0.37	0.41	0.39	0.44	LS	LS	MS	MS	MS
P	0.34	0.34	0.40	0.36	0.35	LS	LS	MS	LS	LS
Q	0.40	0.41	0.42	0.41	0.43	MS	MS	MS	MS	MS
R	0.38	0.39	0.43	0.37	0.42	MS	MS	MS	LS	MS
S	0.34	0.34	0.38	0.36	0.41	LS	LS	MS	LS	MS
T	0.39	0.38	0.45	0.41	0.49	MS	MS	MS	MS	MS

Similar to STC1, the skill indices for most subjects in STC3 are LS, as shown in Table 6.5. It seems that one subject achieved MS in every trial, one in three trials, one in two trials and two in one trial, even if the track has a cornering effect. The skill indices for most subjects are remained at the same level after five trials. Therefore, these results also do not support hypothesis H (G). Thus, there is no difference between a straight track and an elliptical track when the subjects deal with a tyre puncture.

Table 6.5: Skill index for STC3.

Subject	Skill index, J					Class				
	1	2	3	4	5	1	2	3	4	5
A	0.25	0.23	0.22	0.26	0.32	LS	LS	LS	LS	LS
B	0.27	0.30	0.35	0.34	0.38	LS	LS	LS	LS	MS
C	0.32	0.33	0.36	0.31	0.38	LS	LS	LS	LS	MS
D	0.27	0.29	0.32	0.29	0.33	LS	LS	LS	LS	LS
E	0.38	0.41	0.41	0.41	0.43	MS	MS	MS	MS	MS
F	0.30	0.32	0.36	0.39	0.39	LS	LS	LS	MS	MS
G	0.32	0.34	0.33	0.33	0.32	LS	LS	LS	LS	LS
H	0.27	0.30	0.36	0.33	0.32	LS	LS	LS	LS	LS
I	0.32	0.34	0.36	0.34	0.36	LS	LS	LS	LS	LS
J	0.33	0.33	0.34	0.34	0.32	LS	LS	LS	LS	LS
K	0.26	0.26	0.27	0.29	0.34	LS	LS	LS	LS	LS
L	0.28	0.31	0.33	0.30	0.33	LS	LS	LS	LS	LS
M	0.31	0.35	0.39	0.40	0.41	LS	LS	MS	MS	MS
N	0.29	0.32	0.34	0.33	0.31	LS	LS	LS	LS	LS
O	0.32	0.33	0.34	0.32	0.32	LS	LS	LS	LS	LS
P	0.27	0.27	0.28	0.30	0.34	LS	LS	LS	LS	LS
Q	0.29	0.32	0.33	0.33	0.35	LS	LS	LS	LS	LS
R	0.27	0.31	0.36	0.32	0.34	LS	LS	LS	LS	LS
S	0.29	0.32	0.34	0.30	0.34	LS	LS	LS	LS	LS
T	0.32	0.35	0.37	0.37	0.37	LS	LS	LS	LS	LS

For STC4 (Figure 6.6), there is a great difference between a straight track and a square track. It seems that the slippery surface for a long track that has bends and corners gives less effect to human skills. Most subjects are able to achieve HS or at least MS rather than LS from a short straight track. Nonetheless, in trials that have a long stretch of slippery surface (trial 2, trial 4 and trial 5), most subjects are MS. It means that the duration of slippery surface still affects the human skill to deal with an

effect at random locations. Therefore, the skill indices for most subjects are become inconsistent after several trials. Thus, these results also agree with hypothesis H (H).

Table 6.6: Skill index for STC4

Subject	Skill index, J					Class				
	1	2	3	4	5	1	2	3	4	5
A	0.66	0.55	0.72	0.55	0.47	HS	MS	HS	MS	MS
B	0.57	0.67	0.68	0.60	0.70	MS	HS	HS	MS	HS
C	0.65	0.63	0.56	0.60	0.58	HS	HS	MS	MS	MS
D	0.56	0.52	0.54	0.55	0.43	MS	MS	MS	MS	MS
E	0.71	0.67	0.75	0.72	0.68	HS	HS	HS	HS	HS
F	0.60	0.64	0.70	0.71	0.60	MS	HS	HS	HS	MS
G	0.62	0.47	0.74	0.51	0.68	MS	MS	HS	MS	HS
H	0.50	0.53	0.52	0.50	0.56	MS	MS	MS	MS	MS
I	0.59	0.49	0.55	0.54	0.55	MS	MS	MS	MS	MS
J	0.73	0.51	0.73	0.68	0.53	HS	MS	HS	HS	MS
K	0.60	0.60	0.70	0.57	0.55	MS	MS	HS	MS	MS
L	0.60	0.57	0.55	0.55	0.49	MS	MS	MS	MS	MS
M	0.65	0.65	0.72	0.71	0.64	HS	HS	HS	HS	HS
N	0.54	0.49	0.59	0.50	0.61	MS	MS	MS	MS	MS
O	0.64	0.49	0.59	0.58	0.54	HS	MS	MS	MS	MS
P	0.63	0.58	0.71	0.59	0.51	HS	MS	HS	MS	MS
Q	0.59	0.52	0.71	0.54	0.69	MS	MS	HS	MS	HS
R	0.55	0.57	0.54	0.54	0.56	MS	MS	MS	MS	MS
S	0.57	0.47	0.54	0.50	0.47	MS	MS	MS	MS	MS
T	0.72	0.56	0.74	0.70	0.59	HS	MS	HS	HS	MS

6.8.3 AVERAGE SKILL INDEX

Table 6.7: Average skill index for each subject in every STC.

Subject	STC1		STC2		STC3		STC4	
	J	Class	J	Class	J	Class	J	Class
A	0.22	LS	0.34	LS	0.26	LS	0.59	MS
B	0.27	LS	0.43	MS	0.33	LS	0.64	HS
C	0.37	LS	0.45	MS	0.34	LS	0.60	MS
D	0.26	LS	0.36	LS	0.30	LS	0.52	MS
E	0.38	MS	0.47	MS	0.41	MS	0.71	HS
F	0.26	LS	0.40	MS	0.35	LS	0.65	HS
G	0.29	LS	0.40	MS	0.33	LS	0.60	MS
H	0.24	LS	0.36	LS	0.32	LS	0.52	MS
I	0.30	LS	0.39	MS	0.35	LS	0.54	MS
J	0.36	LS	0.40	MS	0.33	LS	0.64	HS
K	0.24	LS	0.38	MS	0.28	LS	0.60	MS
L	0.30	LS	0.39	MS	0.31	LS	0.55	MS
M	0.31	LS	0.43	MS	0.37	MS	0.68	HS
N	0.26	LS	0.37	LS	0.32	LS	0.55	MS
O	0.32	LS	0.40	MS	0.33	LS	0.57	MS
P	0.23	LS	0.36	LS	0.29	LS	0.60	MS
Q	0.27	LS	0.42	MS	0.32	LS	0.61	MS
R	0.29	LS	0.40	MS	0.32	LS	0.55	MS
S	0.27	LS	0.37	LS	0.32	LS	0.51	MS
T	0.37	LS	0.42	MS	0.36	LS	0.66	HS
Average	0.29	LS	0.40	MS	0.33	LS	0.59	MS

The value of the average skill index for each subject in every STC is shown in Table 6.7. It clearly shows that the average skill index for STC1 and STC3 is LS, while STC2 and STC4 is MS. In fact, for STC4, there are six HS subjects despite the effect

occurred. This illustrates that a tyre puncture is more dangerous than a slippery surface. Thus, the hypothesis H (I) is supported.

6.8.4 OVERALL SKILL INDEX FOR EACH SUBJECT

Table 6.8: Average skill indices for EGC and STC (Puncture & Slippery Surface).

Subject	EGC		STC (Puncture)		STC (Slippery)	
	J	Class	J	Class	J	Class
A	0.71	HS	0.24	LS	0.47	MS
B	0.58	MS	0.30	LS	0.54	MS
C	0.61	MS	0.36	LS	0.52	MS
D	0.63	HS	0.28	LS	0.44	MS
E	0.69	HS	0.39	MS	0.59	MS
F	0.64	HS	0.31	LS	0.52	MS
G	0.65	HS	0.31	LS	0.50	MS
H	0.64	HS	0.28	LS	0.44	MS
I	0.61	MS	0.32	LS	0.47	MS
J	0.65	HS	0.35	LS	0.52	MS
K	0.62	MS	0.26	LS	0.49	MS
L	0.59	MS	0.30	LS	0.47	MS
M	0.66	HS	0.34	LS	0.55	MS
N	0.63	HS	0.29	LS	0.46	MS
O	0.62	MS	0.33	LS	0.48	MS
P	0.66	HS	0.26	LS	0.48	MS
Q	0.60	MS	0.30	LS	0.51	MS
R	0.61	MS	0.30	LS	0.48	MS
S	0.60	MS	0.29	LS	0.44	MS
T	0.66	HS	0.36	LS	0.54	MS

Table 6.8 shows the overall skill indices for every subject from EGC (as described in Chapter 5) and two STCs, whether tyre punctures or slippery surface. It can be observed that all subjects are LS in STC (Puncture) except Subject E, who obtained MS. Although Subject E is MS in STC (Puncture), his/her skill in EGC is HS. This means that all human skills in STC (Puncture) are worse than human skills in EGC. Thus, these results are corresponded to hypothesis H (J).

Based on Table 6.8, it also shows that all subjects are MS in STC (Slippery). This means that nine subjects are remain the same skill as in EGC. Other eleven subjects are HS in EGC. Thus, for STC (Slippery), the hypothesis H (J) is only supported for subjects who obtained HS in EGC. For overall analysis, the skill indices for all subjects are deteriorated in STC.

By considering five years as getting experienced either in driving or gaming, the hypothesis H (K) is validated for each subject in STC (Puncture), as shown in Table 6.9. It can be observed that only skill indices of four subjects are corresponded to hypothesis H (K). In other words, Subject B, Subject C and Subject R are not expected to have MS in STC (Puncture) since they are less experienced. Moreover, Subject E is supported hypothesis H (K) because his/her skill index is MS. The skill indices of other subjects are below the expectation in STC (Puncture).

Table 6.9: Hypothesis H (K) validation for each subject in STC (Puncture)

Subject	STC (Puncture)		DE	GE	H (K) supported
	J	Class			
A	0.24	LS	10	1	No
B	0.30	LS	2	1	Yes
C	0.36	LS	0	0	Yes
D	0.28	LS	23	0	No
E	0.39	MS	6	8	Yes
F	0.31	LS	20	0	No
G	0.31	LS	10	5	No
H	0.28	LS	7	0	No
I	0.32	LS	9	6	No
J	0.35	LS	15	3	No
K	0.26	LS	6	1	No
L	0.30	LS	10	0	No
M	0.34	LS	13	4	No
N	0.29	LS	8	2	No
O	0.33	LS	12	4	No
P	0.26	LS	15	0	No
Q	0.30	LS	6	3	No
R	0.30	LS	3	0	Yes
S	0.29	LS	16	3	No
T	0.36	LS	10	5	No

Note: DE – Driving Experience, GE – Gaming Experience.

Table 6.10 shows the hypothesis H (K) validation for each subject in STC (Slippery). Since all subjects are MS in STC (Slippery), the hypothesis H (K) is truly supported. It also shows that, although the subjects are inexperienced (below five years) in driving or gaming, they are able to obtain MS in STC (Slippery).

Table 6.10: Hypothesis H (K) validation for each subject in STC (Slippery)

Subject	STC (Slippery)		DE	GE	H (K) supported
	J	Class			
A	0.47	MS	10	1	Yes
B	0.54	MS	2	1	Yes
C	0.52	MS	0	0	Yes
D	0.44	MS	23	0	Yes
E	0.59	MS	6	8	Yes
F	0.52	MS	20	0	Yes
G	0.50	MS	10	5	Yes
H	0.44	MS	7	0	Yes
I	0.47	MS	9	6	Yes
J	0.52	MS	15	3	Yes
K	0.49	MS	6	1	Yes
L	0.47	MS	10	0	Yes
M	0.55	MS	13	4	Yes
N	0.46	MS	8	2	Yes
O	0.48	MS	12	4	Yes
P	0.48	MS	15	0	Yes
Q	0.51	MS	6	3	Yes
R	0.48	MS	3	0	Yes
S	0.44	MS	16	3	Yes
T	0.54	MS	10	5	Yes

Note: DE – Driving Experience, GE – Gaming Experience.

6.8.5 EFFECTS OF EXPERIENCES AND AGES

The correlation technique is used to show the effects of experience to the skill index in every STC. Table 6.11 shows the correlation coefficient between the skill index, *J*, of each STC and experiences, also between *J* and ages.

Table 6.11: The correlation between the skill indices of every STC, experiences and ages.

J in	DE	GE	Age
STC1	-0.21	0.56	-0.32
STC2	-0.49	0.51	-0.47
STC3	-0.10	0.66	-0.23
STC4	-0.14	0.42	-0.32

Note: **DE** – Driving Experience, **GE** – Gaming Experience.

Based on Table 6.11, it can be observed that the skill index in every STC correlates negatively with driving experience. In other words, although the driving experience is high, it does not help to improve the skill index in STC. However, the relationship is not very significant for STC1, STC3 and STC4. Only STC2 has a moderate effect. Therefore, it seems that the effects in STC have deteriorated the driving experience.

On the other hand, the skill index for all STCs correlates positively with gaming experience. Also, the relationship is moderate for all STCs. It means that the gaming experience helps in handling the simulated car during STC.

Table 6.11 also shows that the skill index in all STCs correlates negatively with the subjects' ages. It means that the older subjects are most likely to have the lower skill index rather than the younger subjects. However, the relationship is not significant for all STCs except for STC2, which has moderate effect.

6.9 SUMMARY

The experiments to obtain the elapsed time and tracking error from 20 human subjects in four STC experiments are described in detail. This chapter also discusses the objectives, scope, hypotheses, the experiment features, the procedures, the results and the analysis. The experiments performed in this chapter have demonstrated that the tracking error is not directly proportional to the elapsed time in most of STC. It also shows that the experiences and ages have less effect to the driving skill in all effects. Apart from that, the analysis shows that the tracking error is become higher during a tyre puncture, in tracks with bends and corners; and during long stretches of slippery surface. The analysis also summarizes that the skill indices in STC are worse than the skill indices in EGC.

CHAPTER 7

DISCUSSION

7.1 INTRODUCTION

The main aim of this thesis is to overcome the problem of current HAM systems in quantifying and classifying human skill as part of human identification in various tasks. Therefore, this chapter discusses the issues and rationales regarding the proposed formula, the experiments and the results. The advantages and the only limitation of proposed formula are also presented. Apart from that, the factors that affected the experimental results are showed.

7.2 SKILL INDEX FORMULA

7.2.1 THE PROPOSED FORMULA

This thesis proposes a linear relationship between the time the task is accomplished and the tracking error in quantifying the skill of any human operator. The formula is evaluated using the logical conditions and based on the definition of skill in HAM. The formula focuses on driving skill in two different conditions: normal driving on five types of track, and sudden transitory conditions when disturbances are involved.

The actual time and error are normalized into a range of zero and one, so that the proposed formula considers the value zero as the best and value one as the worst. Normalized time uses the best theoretical time as a reference, by assuming the track is a straight line, ignoring the corners and braking and using the maximum speed. Therefore, the best time is considered universal for all humans in the designed experiments. On the other hand, normalized error uses the smallest possible human error as a reference, which is obtained from the normal conditions of the experiment. Hence, the smallest error is based on the experiment and subject. In theory, the best error is valued as zero. However, the value zero is not feasible because humans are imperfect and it is impossible to have no error in any experiment.

The value of the skill index is also described in the range of zero to one. However, contrary to time and error, the proposed formula considers the value one for VHS (the best) and value zero for VLS (the worst). Although the value of time and error are only divided into three levels (Small, Medium and Large for error; Fast, Medium and

Slow for time), the value of skill can be classified into five levels: Very Low Skilled (VLS), Low Skilled (LS), Middle Skilled (MS), High Skilled (HS) and Very High Skilled (VHS). By doing this, the proposed skill index can differentiate every human subject into more appropriate levels rather than generalizing them into just three levels, i.e. LS, MS and HS, as done by Sasaki *et al.* (2007).

7.2.2 FORMULA VALIDATION AND COMPARISON

In order to validate the proposed formula and show the comparisons among formulas as explained in Chapter 4, five subjects with synthetic data are used. The skill indices of each formula and level are shown in Table 7.1.

Table 7.1: The comparisons using synthetic data

Subject	T_n	E_n	Sasaki's formula		Fuzzy Logic		Proposed formula	
			J	Level	J	Level	J	Level
1	0.20	0.25	0.78	MS	0.68	HS	0.78	HS
2	0.25	0.60	0.47	MS	0.57	MS	0.58	MS
3	0.50	0.90	0.51	MS	0.25	LS	0.30	LS
4	0.30	0.70	0.42	HS	0.50	MS	0.50	MS
5	0.80	0.10	1.20	Undefined	0.59	MS	0.55	MS

Note: T_n - normalized time, E_n - normalized error.

According to Sasaki's formula, only Subject 4 is highly skilled (HS) and the rest are middle skilled (MS). However, Sasaki's formula cannot determine the skill level for Subject 5 because the value of J is more than 1.17. In theory, Subject 4 has a slower time than Subject 1 and Subject 2, and has a larger error than Subject 1, Subject 2 and

Subject 5. In reality, the level ‘highly skilled’ should be obtained by having the fastest time and the smallest error. Therefore, Sasaki’s formula is proved to be wrong in determining human skill because Subject 4 is supposed to be MS or lower skilled than the other subjects.

The Fuzzy Logic System (FLS) and the proposed formula appear to give a similar level for each subject, although the value of J is different. This shows that the proposed formula is identical to FLS in terms of its logical considerations. For example, the value of J for Subject 1 is 0.78 using the proposed formula and 0.68 for FLS. However, these two values are located in the same range, as shown in Table 4.4 in Chapter 4. Therefore, Subject 1 is classified as highly skilled (HS). In fact, Subject 1 obtained the faster time and the smaller error than the other subjects. This means that Subject 1 should have higher skill than the others as quantified using the proposed formula and FLS.

Interestingly, for Subject 1, the value of J from the proposed formula is the same as that measured using Sasaki’s formula. However, the level of J is different between these two formulas. For Subject 2, the level of J is similar for all three formulas, although the value is different. For Subject 3, FLS and the proposed formula classified his/her skill as low (LS) because he/she obtained an average time and has a larger error than the others. For Subject 4, FLS and the proposed formula provide the same value and level. Although Sasaki’s formula is unable to classify the skill level of Subject 5, FLS and the proposed formula are able to categorise his/her skill due to fact that the measured value of J is located between zero and one.

7.2.3 ADVANTAGES

The proposed formula has five advantages. Firstly, the formula is applied to any human machine system that involves time and error, such as industrial machines, vehicles, power reactors and household appliances. The formula is not only capable of quantifying the skill index in normal conditions, but also in unusual situations when the machine experiences a disturbance or breakdown.

Secondly, the formula has the same ability as the Fuzzy Logic System. However, it can quantify the skill in a more precise way compared to FLS, where the calculated value is based on the defuzzification process, as implemented by Shaw (1993). It means that the measured value from the proposed formula is calculated based on real individual capacity that reflects his/her skill.

Thirdly, no special software or additional learning is needed when using the formula, because it is easy to use and less time is required for learning its steps. Comparable to FLS, which is well known as the ‘black box’ method, and appropriate software such as MATLAB is essential. In other words, the researchers have to learn about FLS and also the software, which is time consuming.

Fourthly, the formula is able to quantify and classify skill using any positive data. It means that there is no restriction if the data is too high or too low, because the data is normalized. By normalizing, the data is simplified into a range between zero and one.

This technique also eliminates the difficulties in measuring the skill index due to a large range.

Finally, the value of the skill index is also always positive and less than one. This means that the skill index can be divided into a proper range for every level, without any exclusion. Moreover, the skill index is classified into five levels, which is enough to classify every human into a specific skill level.

7.2.4 LIMITATION

The only limitation of this formula is that the normalized error is subject-dependant. It might be valid for the sample subjects and does not represent the whole human population. More human subjects from various countries and backgrounds are needed so that the standard or universal value can be determined for tracking error. This might include professional drivers that surely are VHS in the real world.

7.3 THE EXPERIMENTS AND RELATED ISSUES

This research involved two main experiments to implement and verify the proposed skill index. The first experiment is known as Expected and Guided Conditions (EGC), which are normal situations without disturbances. EGC uses five pre-defined track patterns: straight, circular, elliptical, square and triangular. The tracks are varied to determine the skill index for different track features, such as linearity, corners and skill to negotiate. Although this experiment is identical to work done by Igarashi

(2008), his objective was to propose calibration in order to improve machine operation. However, this experiment mainly used to quantify the human driving skill in normal conditions.

The second experiment is known as Sudden Transitory Conditions (STC), and focuses on tyre punctures and slippery surfaces at fixed and random points. Moreover, STC only used three selected tracks. As far as the author is aware, no other researcher has quantified the skill index of the human operator in the aforementioned situations apart from normal conditions. Although Sasaki *et al.* (2007) worked on hovercraft operation, their experiments are still considered normal for hovercraft systems, as they just measured the drift corner. Furthermore, STC is more difficult than EGC because the human subjects are requested to drive the simulated car without any guidance when the disturbances occurred. Compared to EGC, a guideline is provided along the track until the human subject reaches the end point.

There were 20 human subjects involved in both experiments. This number of subjects is enough to use in statistical analysis that involved the reliability and correlation. The subjects were selected according to various driving and gaming experience. This number of human subjects is more than other researchers used in their experiments involving humans, as shown in Table 7.2. Although they used less number of subjects, their objectives and type of experiments are different with this thesis. For example, Itoh *et al.* (2006) used only two subjects in their experiment, to propose a human as a control module. They have measured the tracking error in controlling the aircraft.

Clearly, they did not need more number of subjects to verify their control module as two subjects are appropriate for comparisons.

Table 7.2: Number of subjects used by other researchers.

Experimental work from	No. of Subject(s)
Ertugrul (2007)	13
Kurihara <i>et al.</i> (2004)	12
Sadahiro <i>et al.</i> (2007)	7
Itoh <i>et al.</i> (2006)	2
Tervo <i>et al.</i> (2009)	1
This thesis	20

7.4 RESULTS AND RELATED ISSUES

In all experiments, the subjects were requested to accurately follow the specific lines without stopping until the end point. In EGC, the tracking error is inversely proportional to the elapsed time, because when the time is fast, the possibility of making errors is higher. This statement is supported by all tracks except the circular track, due to fact that the subjects are slowing down or maintaining the speed of the simulated car to handle the steering at all time. Thus, these actions make the time becomes slower and the error is higher.

Table 7.3: Average error for each track in EGC

Track	Average error (Dimensionless)
Straight	0.80
Circular	2.29
Elliptical	1.94
Square	2.90
Triangular	3.62

Table 7.3 shows the value of average error for each track in normal condition. It can be summarized that:

- i) The straight track gives the smallest error and it can be considered that the straight track is the easiest track. However, the small error does not guarantee that the skill index is high, because most subjects had familiarization problems in the first two trials.
- ii) The elliptical track gives a smaller average error than the circular track because less handling of the steering is required. In other words, the human subjects are keeping the steering direction constant without the need to change direction regularly while navigating the elliptical track. This movement yields a smaller error and the elliptical track can be considered similar to the two straight tracks with two corners.

- iii) The triangular track resulted in a larger error compared to the square track because it seems that the 60° turns are more difficult to navigate than the 90° turns.
- iv) The circular and elliptical tracks are non-linear and tend to give a smaller error compared to the square or triangle-shaped tracks, which are linear. This shows that the human subjects are likely to pay more attention when following continuous track(s) even though it is non-linear rather than following the track with 90° or 60° corners. It also seems that there is more tracking error obtained when taking corner(s), when most of the subjects are taking 'short cut' routes to reduce the time. It is observed that when cornering in real life, subjects need to control the car speed properly. However, in the experiment, most of the subjects use the same speed without decreasing it while cornering.

By referring to Figure 1.1 on page 5, these results can verify that the driver error is the most frequently reported contributory factor in accidents. Even for straight track, there is always an error during the driving. This is one of the reasons that the human needs the adaptive mechatronics system in manipulating the machine such as a car.

In STC1 and STC2, some results show that the tracking error is directly proportional to the elapsed time because it eliminates the disturbances much faster in order to reach the end point. In other words, when the time is fast, the error is small. If the subject drives the simulated car slowly, then the effect of STC is increased and the error becomes higher. However, this hypothesis is only supported in straight track. This is because the results in other two STCs (STC3 and STC4) are totally rejected the

hypothesis, due to the fact that the tracks used are long, have bends and corners. These factors also have their own effects to the tracking error.

The type of disturbances during STC also affects the human skill index. When a tyre punctured, whether it occurred at the same place or at random places several times, the humans are still unable to improve their skill effectively. In other words, a tyre puncture is very difficult to handle and dangerous if it happens in real life. Therefore, during this disturbance, humans need adaptive assistance from the machine itself.

As a contrast, although the slippery surface effect happened at random places in different trials, the human skill index actually depends on the period duration of the slippery surface. If the period is short, then the effect can be neglected. But if the period is long, then the skill index decreases. For a longer track, error on the slippery surface might be ignored because its effect is very small and similar to normal conditions.

In terms of human experience, Subject C who has no experience in driving or gaming tends to have the fastest time but with the largest error in straight, square and triangular tracks. This shows that inexperienced drivers have accuracy problem with linear tracks with corner(s) although they can obtain the fastest time. However, Subject C has no problems with the circular and elliptical (nonlinear) tracks.

On the other hand, Subject D who had 23 years of driving experience but no experience in gaming tends to have the smallest error but the slowest time in square and triangular (linear) tracks. It shows that more experienced drivers are taking more care when following the linear tracks with corners. However, in nonlinear tracks, Subject D tends to have an average time and error.

Therefore, in terms of correlation, both experiments are unable to show a significant relationship between driving/gaming experience/ages and skill index with different track patterns or disturbances. In other words, the experiences and ages have less effect in both experiments and can be considered to be a minor factor in improving the skill index.

7.5 RELIABILITY OF THE RESULTS

Due to the fact that experiments are involved the human subjects, the reliability of the results is important. In order to show the reliability, the Cronbach's alpha (α) is measured and shown in Table 7.4 and Table 7.5. The α is coefficient of reliability and commonly used as a measure of the reliability of a trial score for a sample of subjects (Cronbach, 1951).

Table 7.4: The α between the tracks and results for EGC.

Track	TIME	ERROR
Straight	0.85	0.52
Circular	0.85	0.77
Elliptical	0.91	0.91
Square	0.95	0.72
Triangular	0.96	0.89

In EGC and according to Table 7.4, all tracks have a good internal consistency ($\alpha > 0.8$) with time. In fact, three tracks have an excellent reliability ($\alpha > 0.9$) with time, which are Elliptical, Square and Triangular tracks. These results indicate that time obtained from the experiment is reliable in all tracks.

In terms of error in EGC, Table 7.4 also shows that one track has an excellent reliability which is Elliptical, one track has a good reliability (Triangular), and two tracks has an acceptable reliability (Circular and Square). However, Straight track has poor reliability with error. This condition indicates that the subjects are having familiarization problems in the early experiment.

Table 7.5: The α between the tracks and results for STC.

STC	TIME	ERROR
1	0.77	0.74
2	0.89	0.60
3	0.76	0.76
4	0.85	0.69

In STC and based on Table 7.5, all STCs have an acceptable reliability with time. However, in terms of error, only STC1 and STC3 have an acceptable internal consistency, due to the fact that these experiments involved the fixed effects in every trial. Other two STCs have a questionable reliability with error. It can be verified that the effects of these STCs are occurred at random points in each trial.

7.6 CORRELATION AND STATISTICAL ERRORS

Based on Table 7.6, it indicates that elapsed time and tracking error for every track is inversely proportional because the correlation coefficient is negative. These findings support the hypothesis H1 as described in Chapter 5 on page 92. However, only Square and Triangular tracks have strong relationship; Straight track (medium correlation) and Circular and Elliptical tracks (small correlation).

Table 7.6: Correlation between time and error, and its significant level for EGC.

Track	Correlation	Significant level
Straight	-0.449	0.047
Circular	-0.294	0.209
Elliptical	-0.182	0.443
Square	-0.749	0.001
Triangular	-0.592	0.006

By choosing the significant level $\alpha = 0.05$, Table 7.6 also shows that Straight, Circular and Triangular tracks are avoiding the Type I error, because their significant levels are less than α . However, there is possibility that Circular and Elliptical tracks are making Type I error due to fact that the significant level is more than α . In future, this can be minimized by using larger sample size than 20 subjects.

Table 7.7: Correlation between time and error, and its significant level for STC.

STC	Correlation	Significant level
1	0.176	0.459
2	-0.145	0.541
3	-0.444	0.050
4	-0.156	0.510

Table 7.7 shows the correlation and significant level for STC. It can be shown that only STC1 is correlated positively between elapsed time and tracking error. However, this relationship is not significant in terms of statistical. Other three STCs are correlated negatively, but only STC3 has medium correlation. These findings also show that only STC1 supports the hypothesis H(A) as described in Chapter 6 on page 133.

By using significant level $\alpha = 0.05$, similar to EGC, Table 7.7 also indicates that only STC3 is minimized the Type II error, because the significant level $\leq \alpha$. There is possibility that STC1 is making Type I error, whereas STC2 and STC4 are making Type II error, because the significant levels are greater than α . It means that the STC

experiments need to increase the sample size, in order to avoid or minimized the statistical errors in future.

7.7 SUMMARY

In this chapter, the proposed formula is discussed with related issues and rationales. The formula is verified and compared with other methods. The advantages and limitation of the proposed formula are also described in detail. The chapter also makes comparisons with recent researches that relate to this study, as well as discusses the experiments and the results with their related issues. The rationales on some hypotheses are also explained to show their significant in logical conditions. The reliability, correlation and statistical errors of results are also described at the end of this chapter.

CHAPTER 8

CONCLUSIONS AND FURTHER WORK

8.1 CONCLUSIONS

This thesis presents a method that combines human error and elapsed time in the problem of quantifying and classifying human skills to realize the HAM concept. In conclusion, this thesis has achieved the following objectives:

- i. Proposed a linear relationship formula between elapsed time and human error for the skill index.
- ii. Designed a driving simulator in order to investigate human driving skill.
- iii. Developed and implemented a technique to measure human tracking error based on minimum distance in the software simulation.

- iv. Classified the skill index into five levels.
- v. Assessed the driving skill of human subjects in normal conditions using five tracks experimentally.
- vi. Verified the proposed quantification formula in two unexpected conditions experimentally.

Therefore, the main novelties of this research are:

8.1.1 HUMAN SKILL INDEX

For the first time, a new skill index formula is proposed based on the logical conditions and the definition of skill in HAM. This formula involves the linear relationship between normalized error and normalized time. The proposed formula also eliminates the difficulties and limitations of existing techniques, such as the Fuzzy Logic System (FLS) and Sasaki's formula. The skill index acts as an indicator and allows the easy recognition of the differences between humans. It provides the value and the level of human skill based on actual individual capacity in any human machine system.

8.1.2 SKILL IN VARYING CONDITIONS

As a way to implement and verify the proposed formula, this thesis evaluates human driving skill in various situations, whether in normal conditions or in unexpected

conditions. These are done experimentally using a designed driving simulator. This implementation is important in gauging how far human skill changes and how the machine adapts to different conditions. Two types of experiment are performed, referred to as expected and guided conditions (EGC) and sudden transitory conditions (STC). For EGC, human subjects are asked to follow five different tracks which are designed based on usual road patterns in the real world. These tracks differ in terms of linearity and skill to negotiate. For STC, two combinations of effects that can happen when driving are used, occurring both at the same point and at random points in every trial.

8.1.3 HUMAN ERROR BASED ON MINIMUM DISTANCE

A method to calculate the tracking error in the driving simulator is developed and implemented in a simulated program. Minimum distance means that human tracking error is measured based on the shortest Euclidean distance from point to point. Each point of the track is compared to each point of the path used by the human subject. Thus, the tracking error is defined as the average minimum distance between the track and the path. This technique also includes the interpolation method, which eliminates any redundant point in order to maintain 1 unit among the points.

8.1.4 HUMAN SKILL AND EXPERIENCE

For the first time, this research relates human skill and experience, whether driving or gaming, as the experiments mainly involve a computer simulation. This research finds a correlation between the value of the human skill level and the number of years of

experience. This gives an overview about the effects of experience in human driving skill.

8.2 RECOMMENDATIONS FOR FURTHER WORK

From the methodologies, results and analyses presented in this thesis, several opportunities for future work have been identified. Although the current implementation of the proposed skill index depends on offline processes, improvement can be made to integrate the quantification of human operator skill into a real-time experiment. In other words, by developing a dedicated interface and software simulation, the human operators are able to know their skill index on the spot when performing any skill-related tasks in machine manipulation. As a consequence, the full potential of the proposed formula is maximized.

This proposed formula could be improved further by determining the universal error for every task. In other words, this ideal error is true for any machine manipulation that involves a human and does not depend on the subjects. Even though the current practice of using the smallest possible error has been succeeded by presenting individual error, a universal error is still required for the complexity of different applications. This is achievable by sampling more human subjects in various countries and backgrounds, including professional drivers and operators.

In terms of application, the proposed formula can be embedded into a real car system by using appropriate sensors and actuators. However, several issues such as safety and reliability have to be resolved before the actual system can be developed. Furthermore, an adaptive controller could be designed to complete the HAM system. This controller could be used to determine the level of assistance required from the HAM machine.

REFERENCES

- AIGNER, P. & MCCARRAGHER, B. J. (2000) Modeling and Constraining Human Interactions in Shared Control Utilizing a Discrete Event Framework. *IEEE Transactions on Systems, Man, and Cybernetics - Part A: Systems and Humans*, 30, pp. 369 - 379.
- AN, P. E. & HARRIS, J. (1996) An Intelligent Driver Warning System for Vehicle Collision Avoidance. *IEEE Transactions on Systems, Man and Cybernetics, Part A*, 26, pp. 254-261.
- ARAI, T. & FUJITA, Y., Honda Giken Kogyo Kabushiki Kaisha (1998) *Auto Cruise System for Vehicle*, Japan, 5771007.
- BARON, S. & KLEINMAN, D. L. (1968) *The Human as An Optimal Controller and Information Processor*, Cambridge, Mass., BOLT BERANEK AND NEWMAN, I.
- BARON, S., KLEINMAN, D. L. & LEVISON, W. H. (1970) An optimal control model of human response part II: Prediction of human performance in a complex task. *Automatica*, 6, pp. 371-383.
- BAUCKHAGE, C., HANHEIDI, M., WREDE, S., KASTER, T., PFEIFFER, M. & SAGERER, G. (2005) Vision Systems with the Human in the Loop. *EURASIP Journal on Applied Signal Processing 2005*, 2005, pp. 2375-2390.
- BIEN, Z. Z., PARK, K.-H., JUNG, J.-W. & DO, J.-H. (2005) Intention Reading is Essential in Human-Friendly Interfaces for the Elderly and the Handicapped. *IEEE Transactions on Industrial Electronics*, 52, pp. 1500-1505.
- BRESENHAM, J. E. (1965) Algorithm for computer control of a digital plotter. *IBM Systems Journal*, 4, pp. 25-30.
- BUSS, M. & HASHIMOTO, H. (1996) Intelligent Control for Human-Machine Systems. *IEEE/ASME Transactions on Mechatronics*, 1, pp. 50-55.
- CHEN, Y.-T. & TSENG, K.-T. (2007) Developing a Multiple-angle Hand Gesture Recognition System for Human Machine Interactions. *33rd Annual Conference of the Industrial Electronics Society 2007*, pp. 489-492.
- COOPER, R. A. (1995) Intelligent Control of Power Wheelchairs. *IEEE Engineering in Medicine and Biology Magazine*.
- CRONBACH, L. J. (1951). Coefficient alpha and the internal structure of tests. *Psychometrika*, 16(3), 297-334.

- DEARDEN, A. M. & HARRISON, M. D. (1996) Impact and the Design of the Human-Machine Interface. *Eleventh Annual Conference on Computer Assurance 'Systems Integrity. Software Safety. Process Security' COMPASS '96*, pp. 161-170.
- DELICE, I. I. & ERTUGRUL, S. (2007) Intelligent Modeling of Human Driver: A Survey. *IEEE Intelligent Vehicles Symposium 2007*, pp. 648 - 651.
- DEPARTMENT.FOR.TRANSPORT (2009) *Reported Road Casualties Great Britain: 2009 (Annual Report)* London, THE.STATIONERY.OFFICE.
- DIX, A., FINLAY, J., ABOWD, G. & BEALE, R. (1998) *Human-Computer Interaction*, Second Edition, Prentice Hall Europe.
- DUNCAN, J., WILLIAMS, P. & BROWN, I. (1991) Components of driving skill: experience does not mean expertise. *Journal of Ergonomics* 34, pp. 919-937.
- ERTUGRUL, S. (2007) Predictive modeling of human operators using parametric and neuro-fuzzy models by means of computer-based identification experiment. *Engineering Applications of Artificial Intelligence*, 21, pp. 259-268.
- FURUTA, K. (2003) Control of pendulum: from Super Mechano-System to Human Adaptive Mechatronics. *42nd IEEE Conference on Decision and Control 2003*, 2, pp. 1498 - 1507.
- FURUTA, K. (2004) What is Human Adaptive Mechatronics? *8th International Conference on Mechatronics Technology 2004*, pp. 543-549.
- FURUTA, K. (2005) Guest Editorial. *IEEE Transactions on Industrial Electronics*, 52, pp. 1194-1195.
- FURUTA, K., IWASE, M. & HATAKEYAMA, S. (2005) Internal Model and Saturating Actuation in Human Operation From View of Human Adaptive Mechatronics. *IEEE Transactions on Industrial Electronics*, 52, pp. 1236-1245.
- FURUTA, K., KADO, Y. & SHIRATORI, S. (2006) Assisting Control in Human Adaptive Mechatronics - Single Ball Juggling -. *IEEE International Conference on Control Applications*, pp. 545-550.
- FURUTA, K., KADO, Y. & SHIRATORI, S. (2007) Identification of Dynamic Characteristics in Human Operation. *IEEE International Conference on Systems, Man and Cybernetics 2007*, pp. 2977 - 2982.
- FURUTA, K. & XU, Y. (2001) Super Mechano-Systems Project. *Advanced Robotics*, 15, pp. 111 - 123.

- GAINES, B. R. (1969) Linear and Nonlinear Models of the Human Controller. *International Journal of Man-Machine Studies* 1, pp. 333-360.
- GOSSELIN, C. M. (2006) Adaptive Robotic Mechanical Systems: A Design Paradigm. *Journal of Mechanical Design*, 128, pp. 192-198.
- GOVINDARAJ, T. & ROUSE, W. B. (1981) Modeling the Human Controller in Environments That Include Continuous and Discrete Tasks. *IEEE Transactions on Systems, Man and Cybernetics*, 11, pp. 410-417.
- GREENBERG, A. D. & SMALL, R. L. (1993) Improving Human Reliability Through Error Monitoring. *Annual Reliability and Maintainability Symposium 1993*, pp. 281-287.
- HARASHIMA, F. & SUZUKI, S. (2006) Human Adaptive Mechatronics - Interaction and Intelligence. *9th International Workshop on Advanced Motion Control 2006*, pp. 1 - 8.
- HIDAKA, K. (2005) Adaptive Weighting Parameter via Human Arm Action. *9th International Conference on Mechatronics Technology 2005*, pp. T3-1, ICMT-147 [CD-Rom].
- HIDAKA, K., SAIDA, K. & SUZUKI, S. (2006) Relation between Skill level and Input-output time delay. *The 2006 IEEE International Conference on Control Applications* pp. 557-561.
- HOFFMAN, R. R. & YATES, J. F. (2005) Decision Making [Human-Centered Computing]. *IEEE Intelligent Systems*, 20, pp. 76-83.
- HORTON, I. (2008) *Ivor Horton's Beginning Visual C++ 2008*, Indianapolis, Wiley Publishing, Inc.
- HWANG, G. & HASHIMOTO, H. (2006) Toward the Haptic Guidant Tele-Micromanipulation. *4th IFAC Symposium on Mechatronic System*, pp. 472-477.
- HYRSKYKARI, A. (2006) Utilizing eye movements: Overcoming inaccuracy while tracking the focus of attention during reading. *Computers in Human Behavior*, 22, pp. 657-671.
- IGARASHI, H. (2008a) Adaptive assist for mobile vehicle operation on human perception. *10th IEEE International Workshop on Advanced Motion Control, 2008 (AMC '08)*, pp. 405 - 410.
- IGARASHI, H. (2008b) Human Adaptive Calibration for Machine Operation Without Awareness. *Journal of Robotics and Mechatronics*, 20, pp. 595 - 601.

- IGARASHI, H. (2008c) Subliminal calibration for machine operation systems. *International Conference on Control, Automation and Systems 2008*, pp. 2812-2817.
- IGARASHI, H., KATO, Y., TAKEYA, A., SUZUKI, S. & KAKIKURA, M. (2005a) Teleoperation System for Quadruped Robots with HAM - Support Functions to Reduce Misrecognitions -. *International Conference on Control, Automation and Systems 2005*, pp. 17ICCAS205.
- IGARASHI, H., SHIRASAKA, S., SUZUKI, S. & KAKIKURA, M. A. K. M. (2005b) Teleoperation system for multiple robots with HAM: free gait for following motion of quadruped robots. *IEEE International Workshop on Robot and Human Interactive Communication (ROMAN), 2005*, pp. 484-489.
- IGARASHI, H., TAKEYA, A., HARASHIMA, F. & KAKIKURA, M. A. K. M. (2006) Human Adaptive Assist Planning for Teleoperation. *32nd Annual Conference on IEEE Industrial Electronics (IECON 2006)*, pp. 4522-4527.
- IGARASHI, H., TAKEYA, A., KUBO, Y., SUZUKI, S., HARASHIMA, F. & KAKIKURA, M. (2005c) Human Adaptive GUI Design for Teleoperation System. *31st Annual Conference of IEEE Industrial Electronics Society (IECON) 2005*, pp. 1973-1978.
- IGARASHI, H., TAKEYA, A., SHIRASAKA, S., SUZUKI, S. & KAKIKURA, M. (2005d) Adaptive Teleoperation System with HAM - GUI Control Based on Human Sensitivity Characteristics - *9th International Conference on Mechatronics Technology 2005*, pp. T3-1, ICMT-111 [CD-Rom].
- ITOH, E. & SUZUKI, S. (2006) A New Approach to Automation That Takes Account of Adaptive Nature of Pilot Maneuver. *World Automation Congress (WAC) '06*, pp. 1-8.
- IVANCIC, I. K. & HESKETH, B. (2000) Learning from errors in a driving simulation: effects on driving skill and self-confidence. *Ergonomics*, 43, pp. 1966-1984.
- IWASE, M., ASTOM, K. J., FURUTA, K. & AKESSON, J. (2006a) Analysis of Safe Manual Control by Using Furuta Pendulum. *IEEE International Conference on Control Applications 2006 (CCA '06)*, pp. 568-572.
- IWASE, M., HATAKEYAMA, S. & FURUTA, K. (2006b) Analysis of Intermittent Control Systems by Human Operations. *32nd Annual Conference on IEEE Industrial Electronics (IECON) 2006*, pp. 4516 - 4521.

- IWASE, M., SHOSHIRO, H. & FURUTA, K. (2005) Analysis of Intermittent Control Systems by Human Operations. *31st Annual Conference of IEEE Industrial Electronics Society (IECON) 2005*, pp. 56-60.
- IWATA, H. & SUGANO, S. (2005) Human-Robot-Contact-State Identification Based on Tactile Recognition. *IEEE Transactions on Industrial Electronics*, 52, pp. 1468-1477.
- JANG, J.-S. R. (1993) ANFIS: Adaptive-Network-Based Fuzzy Inference System. *IEEE Transactions on Systems, Man and Cybernetics*, 23, pp. 665-685.
- JENSEN, B., TOMATIS, N., MAYOR, L., DRYGAJLO, A. & SIEGWART, R. (2005) Robots meet Humans-Interaction in Public Spaces. *IEEE Transactions on Industrial Electronics*, 52, pp. 1530-1546.
- KADO, Y., PAN, Y. & FURUTA, K. (2006) Control System for Skill Acquisition - Balancing Pendulum Based on Human Adaptive Mechatronics-. *IEEE International Conference on Systems, Man, and Cybernetics*, 5, pp. 4040-4045.
- KATSURA, S., MATSUMOTO, Y. & OHNISHI, K. (2005) Realization of "Law of Action and Reaction" by Multilateral Control. *IEEE Transactions on Industrial Electronics*, 52, pp. 1196-1205.
- KAWAMURA, K. (2005) Cognitive Approach to a Human Adaptive Robot Development. *IEEE International Workshop on Robot and Human Interactive Communication (ROMAN) 2005*, pp. 629-634.
- KAWATO, M. (1999) Internal Models for Motor Control and Trajectory Planning. *Current Opinion in Neurobiology*, 9, pp. 718-727.
- KLEINMAN, D. L., BARON, S. & LEVISON, W. H. (1970) An Optimal Control Model of Human Response Part I: Theory and Validation. *Automatica*, 6, pp. 357-369.
- KOBAYASHI, H., OHYAMA, Y., SHE, J.-H., HOSAKA, M. & HASHIMOTO, H. (2004) Transfer Function Representation of Situated Human's Controller. *The 30th Annual Conference of the IEEE Industrial Electronics Society*, pp. 653-656.
- KOBAYASHI, H., SUZUKI, S. & YASUDA, T. (2005) Brain Activation During a Manipulation Task and Working Memory Hypothesis. *IEEE International Workshop on Robot and Human Interaction Communication 2005*, pp. 611 - 616.
- KOBAYASHI, H., YASUDA, T. & SHINOZAKI, S. (2008) Use of Visual Working Memory in a Manipulative Task. *International Conference on Control, Automation and Systems 2008*, pp. 2807-2811.

- KOFMAN, J., WU, X., LUU, T. J. & VERMA, S. (2005) Teleoperation of a Robot Manipulator Using a Vision-Based Human-Robot Interface. *IEEE Transactions on Industrial Electronics*, 52, pp. 1206-1219.
- KOIVO, A. J. & REPPERGER, D. W. (1997) Skill evaluation of human operators. *IEEE International Conference on Systems, Man, and Cybernetics*, 3, pp. 2103-2108.
- KULIC, D. & CROFT, E. (2007) Pre-collision Safety Strategies for Human-Robot Interaction. *Autonomous Robots*, 22, pp. 149-164.
- KURIHARA, K., SUZUKI, S. & FURUTA, K. (2006) Elucidation of Skilled Human Controller on Stabilization with Voluntary Motion. *IEEE International Conference on Control Applications 2006*, pp. 573 - 578.
- KURIHARA, K., SUZUKI, S., HARASHIMA, F. & FURUTA, K. (2004) Human Adaptive Mechatronics (HAM) for Haptic System. *30th Annual Conference of IEEE Industrial Electronics Society 2004*, pp. 647 - 652.
- LEE, J.-S., ZHOU, M.-C. & HSU, P.-L. (2005) An Application of Petri Nets to Supervisory Control for Human-Computer Interactive Systems. *IEEE Transactions on Industrial Electronics*, 52, pp. 1220-1226.
- LEVISON, W. H., BARON, S. & KLEINMAN, D. L. (1969) A Model for Human Controller Remnant. *IEEE Transactions on Man Machine Systems*, 10, pp. 101-108.
- MAEDA, Y., SUZUKI, S. & HIDAKA, K. (2007) Skill Analysis of Wheel Mobile Robot Operation. *International Conference on Control, Automation and Systems 2007 (ICCAS '07)*, pp. 2620 - 2627.
- MAEDA, Y., SUZUKI, S., IGARASHI, H. & HIDAKA, K. (2006) Evaluation of Human Skill in Teleoperation System. *International Joint Conference SICE-ICASE 2006*, pp. 5339-5344.
- MAMDANI, E. H. & ASSILIAN, S. (1975) An experiment in Linguistic Synthesis with a Fuzzy Logic Controller. *International Journal of Man-Machine Studies*, 7, pp. 1-13.
- MASAMUNE, K., OHNUMA, K., YOSHIMITSU, K., OHSHIMA, K., FUKUI, Y. & MIYAWAKI, F. (2005) Development of HAM Surgical Support System for Laparoscopic Surgery - Analysis of Intraoperative Motion of a Surgeon for Surgical Scenario - 9th International Conference on Mechatronics Technology 2005, pp. T3-1, ICMT-121 [CD-Rom].

- MASAMUNE, K., TAKEDA, T. & OHSHIMA, K. (2004) Evaluation of the Skill for Operating Minimally Invasive Spine Surgery Robot toward HAM based Surgery System. *8th International Conference on Mechatronics Technology 2004*, pp. 555-559.
- MCCALL, J. C. & TRIVEDI, M. M. (2007) Driver Behavior and Situation Aware Brake Assistance for Intelligent Vehicles. *Proceedings of the IEEE*, 95, pp. 374-387.
- MCRUER, D. (1980) Human dynamics in man-machine systems. *Automatica*, 16, pp. 237-253.
- MCRUER, D. T. & JEX, H. R. (1967) A Review of Quasi-Linear Pilot Models. *IEEE Transactions on Human Factors in Electronics*, 8, pp. 231-249.
- MCRUER, D. T. & KRENDEL, E. S. (1959a) The human operator as a servo system element Part I. *Journal of the Franklin Institute*, 267, pp. 381-403.
- MCRUER, D. T. & KRENDEL, E. S. (1959b) The human operator as a servo system element Part II. *Journal of the Franklin Institute*, 267, pp. 511-536.
- MCRUER, D. T. & KRENDEL, E. S. (1962) The Man-Machine System Concept. *Proceedings of the Institute of Radio Engineers*, 50, pp. 1117-1123.
- MIALL, R. C., WEIR, D. J., WOLPERT, D. M. & STEIN, J. F. (1993) Is the Cerebellum a Smith Predictor? *Journal of Motor Behavior*, 25, pp. 203-216.
- MILLER, D. C. & ELKIND, J. I. (1967) The Adaptive Response of the Human Controller to Sudden Changes in Controlled Process Dynamics. *IEEE Transactions on Human Factors in Electronics*, HFE-8, pp. 218 - 223.
- MILLER, R. L., JOSE, S. & HARPER, T. P., National Semiconductor Corporation (1994) *Anti-lock braking system*, US, 5372410.
- MILOT, D. R., (2006) *Vehicle Stability Control Utilizing Static Tire Data*, US, US 2006/0190150 A1.
- MITSUNAGA, N., SMITH, C., KANDA, T., ISHIGURO, H. & HAGITA, N. (2008) Adapting Robot Behavior for Human-Robot Interaction. *IEEE Transactions on Robotics*, 24, pp. 911-916.
- MIYASHITA, O., TSUKAMOTO, S., KUUSIK, A., MIYATA, D., YOSHIDA, T., VAIN, J. & ISHIGAMI, S. (2004) A Human-Adaptive-Mechatronics Assisted System for Training Constructional Ability. *8th International Conference on Mechatronics Technology 2004*, pp. 550-554.

- MIYASHITA, T., TAJIKA, T., ISHIGURO, H., KOGURE, K. & HAGITA, N. (2007) Haptic Communication Between Humans and Robots. IN THRUN, S., BROOKS, R. & DURRANT-WHYTE, H. (Eds.) *Robotics Research*. Berlin/Heidelberg, Springer.
- MIYAWAKI, F., MASAMUNE, K., SUZUKI, S., YOSHIMITSU, K. & VAIN, J. (2005) Scrub Nurse Robot System-Intraoperative Motion Analysis of a Scrub Nurse and Timed-Automata-Based Model for Surgery. *IEEE Transactions on Industrial Electronics*, 52, pp. 1227-1235.
- MUTLU, B. & FORLIZZI, J. (2008) Robots in Organizations: the Role of Workflow, Social, and Environmental Factors in Human-Robot Interaction. *The 3rd ACM/IEEE International Conference on Human Robot Interaction*, pp. 287-294.
- NECHYBA, M. C. & XU, Y. (1997) Human Control Strategy: Abstraction, Verification, and Replication. *IEEE Control Systems Magazine*.
- PAGE, C. V. (1969) Human experience in artificial intelligence. *Spectrum, IEEE*, 6, pp. 67-74.
- PALMROTH, L. (2011) *Performance Monitoring and Operator Assistance Systems in Mobile Machines*, PhD, Tampere University of Technology.
- PARK, S. & SHERIDAN, T. B. (2004) Enhanced Human-Machine Interface in Braking. *IEEE Transactions on Systems, Man, and Cybernetics - Part A: Systems and Humans*, 34, pp. 615-629.
- PHATAK, A., MEHRA, R. & DAY, C. (1975) Application of System Identification to Modeling the Human Controller Under Stress Conditions. *IEEE Transactions on Automatic Control*, 20, pp. 657 - 664.
- PHILLIPS, C. A., REPPERGER, D. W., KINSLER, R., BHARWANI, G. & KENDER, D. (2007) A Quantitative Model of the Human-Machine Interaction and Multi-task Performance: A Strategy Function and the Unity Model Paradigm. *Computers in Biology and Medicine*, 37, pp. 1259-1271.
- PILUTTI, T. & ULSOY, A. G. (1999) Identification of Driver State for Lane-keeping Tasks. *IEEE Transactions on Systems, Man and Cybernetics, Part A*, 29, pp. 486-502.
- RANDOLPH, N. & GARDNER, D. (2008) *Professional Visual Studio 2008*, Indianapolis, Wiley Publishing, Inc.

- RANI, P., SARKAR, N. & ADAMS, J. (2007) Anxiety-based affective communication for implicit human-machine interaction. *Advanced Engineering Informatics*, 21, pp. 323-334.
- RENCKEN, W. D. & DURRANT-WHYTE, H. F. (1993) A Quantitative Model for Adaptive Task Allocation in Human-Computer Interfaces. *IEEE Transactions on Systems, Man, and Cybernetics* 23, pp. 1072-1090.
- RODGERS, J. L. & NICEWANDER, W. A. (1988) Thirteen Ways to Look at the Correlation Coefficient. *The American Statistician*, 42, pp. 59-66.
- ROUSE, W. B., HAMMER, J. M. & LEWIS, C. M. (1989) On capturing human skills and knowledge; algorithmic approaches to model identification. *IEEE Transactions on Systems, Man and Cybernetics*, 19, pp. 558-573.
- SAARI, T. (2009) Modeling positive experiences in human-computer interaction. *Human System Interactions, 2009. HSI '09. 2nd Conference on*, pp. 528-535.
- SADAHIRO, T., HAMAZAKI, M., MIYAWAKI, F., YOSHIMITSU, K. & MASAMUNE, K. (2007) Laparoscopic Skill Measurement with COP to realize a HAM Scrub Nurse Robot System. *IEEE International Conference on Systems, Man and Cybernetics 2007*, pp. 2983 - 2988.
- SAIDA, K., SUZUKI, S., MAEDA, Y. & HIDAKA, K. (2006) Skill Analysis in Human Tele-operation Using Dynamic Image. *32nd Annual Conference on IEEE Industrial Electronics, IECON 2006*, pp. 4528-4533.
- SALVUCCI, D. D. (2006) Modeling Driver Behavior in a Cognitive Architecture. *Human Factors: The Journal of the Human Factors and Ergonomics Society*, 48, pp. 362-380.
- SARRAFZADEH, A., ALEXANDER, S., DADGOSTAR, F., FAN, C. & BIGDELI, A. (2008) "How do you know that I don't understand?" A look at the future of intelligent tutoring systems. *Computers in Human Behavior*, 24, pp. 1342-1363.
- SASAKI, M., INOOKA, H. & ISHIKURA, T. (1990) Manual Control of a Flexible Arm and its Application to an Automatic Control System. *IEEE Transactions on Systems, Man and Cybernetics*, 20, pp. 718-722.
- SASAKI, T., TAKEYA, A., IGARASHI, H. & SUZUKI, S. (2007) Operation Skill Quantification for Mobile Vehicle Operation. *SICE Annual Conference 2007*, pp. 274-279.

- SCHIELE, A. & VAN DER HEM, F. C. T. (2006) Kinematic Design to Improve Ergonomics in Human Machine Interaction. *IEEE Transactions on Neural Systems and Rehabilitation Engineering*, 14, pp. 456-469.
- SCHWEITZER, G. (1996) Mechatronics for the Design of Human-Oriented Machines. *IEEE/ASME Transactions on Mechatronics*, 1, pp. 120-126.
- SENDERS, J. W. (1964) The Human Operator as a Monitor and Controller of Multidegree of Freedom Systems. *IEEE Transactions on Human Factors in Electronics*, 5, pp. 2-5.
- SHAW, I. S. (1993) Fuzzy model of a human control operator in a compensatory tracking loop. *International Journal of Man-Machine Studies*, 39, pp. 305-332.
- SHERIDAN, T. B. & FERRELL, W. R. (1981) *Man-Machine Systems : Information, Control, and Decision Models of Human Performance*, Cambridge, The MIT Press.
- SOFFKER, D. (2001) From Human-Machine-Interaction Modeling to New Concepts Constructing Autonomous Systems : A Phenomenological Engineering-Oriented Approach. *Journal of Intelligent and Robotic Systems*, 32, pp. 191-205.
- STEFANOV, D. & BIEN, Z. Z. (2004) Advances in Human-Friendly Robotic Technologies for Movement Assistance/Movement Restoration for People with Disabilities. IN BIEN, Z. Z. & STEFANOV, D. (Eds.) *Advances in Rehabilitation Robotics, LNCIS 306*. Berlin Heidelberg, Springer-Verlag
- SUGITA, T., SUZUKI, S., KOLODKO, J. & IGARASHI, H. (2007) Development of Head-Mounted Eye Tracking System Achieving Environmental Recognition Ability. *Annual Conference SICE 2007*, pp. 1887 - 1891.
- SUZUKI, S. (2010) Human Adaptive Mechatronics: Skill Acquisition in Machine Manipulation. *IEEE Industrial Electronics Magazine*. IEEE.
- SUZUKI, S., FURUTA, K. & HARASHIMA, F. (2005a) Overview of Human Adaptive Mechatronics and Assist-control to Enhance Human's Proficiency. *International Conference on Control, Automation and Systems*, pp. 1759-1765.
- SUZUKI, S. & HARASHIMA, F. (2005) Human Adaptive Mechatronics. *9th International Conference on Intelligent Engineering System (INES) 2005*, pp. 11-16.
- SUZUKI, S. & HARASHIMA, F. (2010) Skill Evaluation from Observation of Discrete Hand Movements during Console Operation. *Journal of Robotics*, 2010, pp. 13.

- SUZUKI, S., HARASHIMA, F. & KURIHARA, K. (2006a) Assist Control and its Tuning Method for Haptic System. *9th IEEE International Workshop on Advanced Motion Control 2006*, pp. 374-379.
- SUZUKI, S., HARASHIMA, F., PAN, Y. & FURUTA, K. (2005b) Skill Analysis of Human in Machine Operation. *International Conference on Neural Networks and Brain 2005*, 3, pp. 1556 - 1561.
- SUZUKI, S., KOBAYASHI, H. & HARASHIMA, F. (2007a) Brain Monitoring Analysis of Skill on Voluntary Motion. *International Conference on Control, Automation and Systems 2007*, pp. 1178 - 1182.
- SUZUKI, S., KURIHARA, K., FURUTA, K. & HARASHIMA, F. (2006b) Assistance Control on a Haptic System for Human Adaptive Mechatronics. *Advanced Robotics*, 20, pp. 323-348.
- SUZUKI, S., KURIHARA, K., FURUTA, K., HARASHIMA, F. & PAN, Y. (2005c) Variable Dynamic Assist Control on Haptic System for Human Adaptive Mechatronics. *44th IEEE Conference on Decision and Control, and the European Control Conference 2005*, 5, pp. 4596-4601.
- SUZUKI, S., PAN, Y. & KURIHARA, K. (2004a) Voluntary Operation Assistance Based on Human Adaptive Mechatronics (HAM) concept. *8th International Conference on Mechatronics Technology 2004*, pp. 566-571.
- SUZUKI, S., SUZUKI, Y., BABA, Y. & FURUTA, K. (2005d) Human Skill and Brain Activity in Machine Operation. *31st Annual Conference of IEEE Industrial Electronics Society (IECON) 2005*, pp. 1967-1972.
- SUZUKI, S., TOMOMATSU, N., HARASHIMA, F. & FURUTA, K. (2004b) Skill Evaluation based on State-Transition Model for Human Adaptive Mechatronics (HAM). *The 30th Annual Conference of the IEEE Industrial Electronics Society*, pp. 641-646.
- SUZUKI, S., WATANABE, Y., IGARASHI, H. & HIDAKA, K. (2007b) Human Skill Elucidation Based on Gaze Analysis for Dynamic Manipulation. *IEEE International Conference on Systems, Man and Cybernetics 2007*, pp. 2989 - 2994.
- SUZUKI, T., SEKIZAWA, S., INAGAKI, S., HAYAKAWA, S., TSUCHIDA, N., TSUDA, T. & FUJINAMI, H. (2005e) Modeling and Recognition of Human Driving Behavior based on Stochastic Switched ARX model. *44th IEEE*

- Conference on Decision and Control and the European Control Conference 2005*, pp. 5095-5100.
- SUZUKI, Y., PAN, Y., SUZUKI, S., KURIHARA, K. & FURUTA, K. (2006c) Human Operation with XY-Stages -Human Adaptive Mechatronics-. *IEEE International Conference on Systems, Man, and Cybernetics 2006*, pp. 4034-4039.
- SUZUKI, Y., TAKASE, H., PAN, Y., ISHIKAWA, J. & FURUTA, K. (2008) Learning process of bimanual coordination. *International Conference on Control, Automation and Systems 2008*, pp. 2830-2835.
- TAKAIWA, M. & NORITSUGU, T. (1999) Application of Pneumatic Parallel Manipulator as Haptic Human Interface. *IEEE/ASME International Conference on Advanced Intelligent Mechatronics 1999*, pp. 185 - 190.
- TAKASE, H., KOMINE, T. & FURUTA, K. (2005) Postural Sway during Sensory-Motor Task. *9th International Conference on Mechatronics Technology 2005*, pp. T3-1, ICMT-111 [CD-Rom].
- TANAKA, Y. & IWATA, Y., Aisin Seiki Kabushiki Kaisha (2005) *Parking assist system*, Japan, 6898495.
- TANG, J., ZHAO, Q. & HUANG, J. (2007) Application of "Human-In-the-Loop" Control to a Biped Walking-Chair Robot. *IEEE International Conference on Systems, Man and Cybernetics 2007*, pp. 2431-2436.
- TERVO, K. (2010) *Human Adaptive Mechatronics Methods for Mobile Working Machines*, Ph.D, Aalto University.
- TERVO, K., BOCCA, M., ERIKSSON, L. M. & MANNINEN, A. (2009) Wireless joystick control for human adaptive mechatronics applications: Case trolley crane. *International Conference on Networking, Sensing and Control (ICNSC) '09*, pp. 19-24.
- TERVO, K., PALMROTH, L. & KOIVO, H. (2010) Skill Evaluation of Human Operators in Partly Automated Mobile Working Machines. *IEE Transaction on Automation Science and Engineering*, 7, pp. 133 - 142.
- TU, J., TAO, H. & HUANG, T. (2007) Face as mouse through visual face tracking. *Computer Vision and Image Understanding*, 108, pp. 35-40.
- TUSTIN, A. (1947) The nature of the operator's response in manual control and its implications for controller design. *Journal IEE (London)*, 94, pp. 190-202.

- UENO, A., MANABE, S. & UCHIKAWA, Y. (2005) A Real-Time Sound Feedback System with DSP for Maintaining Alertness Level and Analysis of Arousal Reaction Induced by the Sound. *9th International Conference on Mechatronics Technology 2005*, pp. T3-1, ICMT-140 [CD-Rom].
- UENO, A. & UCHIKAWA, Y. (2004) An Approach to Quantification of Human Alertness Using Dynamics of Saccadic Eye Movement - For an Application of Human Adaptive Mechatronics - *8th International Conference on Mechatronics Technology 2004*, pp. 560-565 [CD-Rom].
- VENEMA, S. C. & HANNAFORD, B. (2001) A Probabilistic Representation of Human Workspace for Use in the Design of Human Interface Mechanisms. *IEEE/ASME Transactions on Mechatronics*, 6, pp. 286-294.
- WEIR, D. H. & MCRUER, D. T. (1970) Dynamics of Driver Vehicle Steering Control. *Automatica*, 6, pp. 87-98.
- WEWERINKE, P. H. (1986) Model of the Human Controller of A Dynamic System. *25th Conference on Decision and Control*, pp. 1527-1528.
- WHITTINGHAM, R. B. (2004) *The Blame Machine: Why Human Error Causes Accidents*, Butterworth-Heinemann, Elsevier.
- XU, Y., SONG, J., NECHYBA, M. C. & YAM, Y. (2002) Performance Evaluation and Optimization of Human Control Strategy. *Journal of Robotics and Autonomous Systems*, 39, pp. 19-36.
- YAMADA, T. (1993) Human-Machine Interface for Electronic Equipment. *The 10th TRON Project International Symposium*, pp. 45-46.
- YASUDA, T. & KOBAYASHI, H. (2008) Strategy changes and activation of the prefrontal cortex. *International Conference on Control, Automation and Systems 2008*, pp. 2818 - 2823.
- YOSHIMITSU, K., TANAKA, T., OHNUMA, K., MIYAWAKI, F., HASHIMOTO, D. & MASAMUNE, K. (2005) Prototype Development of Scrub Nurse Robot for Laparoscopic Surgery. *International Congress Series*, 1281, pp. 845-850.
- ZADEH, L. A. (1973) Outline of a New Approach to the Analysis of Complex Systems and Decision Processes. *IEE transaction on Systems, Man and Cybernetics*, SMC-3, pp. 28-44.

APPENDIX 1: RESULTS FOR EGC

1(A): STRAIGHT TRACK

Subject	Time (s)							Error (dimensionless)						
	T1	T2	T3	T4	T5	SD	Tave	E1	E2	E3	E4	E5	SD	Eave
A	11.14	11.42	12.09	11.47	11.20	0.38	11.47	1.66	0.40	0.40	0.39	0.40	0.56	0.65
B	11.19	11.19	11.28	11.19	11.20	0.04	11.21	0.71	1.07	0.85	1.01	0.52	0.22	0.83
C	11.13	11.00	11.31	11.28	11.16	0.13	11.18	1.26	1.65	0.96	1.04	1.01	0.29	1.18
D	11.89	12.02	12.25	11.67	11.64	0.25	11.89	0.88	0.47	0.61	1.17	0.74	0.27	0.77
E	11.11	11.11	11.20	11.13	11.25	0.06	11.16	1.31	1.19	0.40	0.40	0.40	0.47	0.74
F	15.20	14.42	12.81	11.81	11.50	1.62	13.15	0.79	1.08	0.39	0.40	0.39	0.31	0.61
G	11.53	11.39	11.34	11.28	11.33	0.10	11.37	0.53	0.94	0.48	0.70	0.40	0.22	0.61
H	11.41	11.41	11.42	11.23	11.20	0.11	11.33	1.98	1.17	0.92	0.39	0.89	0.58	1.07
I	11.05	11.38	11.25	11.17	11.24	0.12	11.22	0.62	0.78	1.06	0.68	0.40	0.24	0.71
J	12.24	11.91	12.36	12.56	12.27	0.24	12.27	0.99	0.76	0.57	1.12	0.49	0.27	0.79
K	11.16	11.31	11.69	11.33	11.20	0.21	11.34	1.18	0.73	0.63	0.70	0.46	0.27	0.74
L	11.51	11.51	11.78	11.48	11.40	0.15	11.53	1.07	1.06	0.78	1.10	0.88	0.14	0.98
M	13.16	12.77	12.01	11.47	11.38	0.79	12.15	1.05	1.13	0.40	0.40	0.40	0.38	0.67
N	11.47	11.40	11.38	11.26	11.27	0.09	11.35	1.25	1.06	0.70	0.55	0.64	0.30	0.84
O	11.64	11.64	11.81	11.87	11.75	0.10	11.74	0.81	0.77	0.81	0.90	0.44	0.18	0.75
P	13.17	12.92	12.45	11.64	11.35	0.79	12.31	1.23	0.74	0.40	0.40	0.39	0.36	0.63
Q	11.36	11.29	11.31	11.23	11.27	0.05	11.29	0.62	1.01	0.66	0.86	0.46	0.21	0.72
R	11.27	11.20	11.37	11.26	11.18	0.07	11.25	1.62	1.41	0.94	0.71	0.95	0.38	1.13
S	11.47	11.70	11.75	11.42	11.44	0.16	11.55	0.75	0.63	0.83	0.92	0.57	0.15	0.74
T	11.67	11.51	11.78	11.84	11.76	0.13	11.71	1.15	0.97	0.48	0.76	0.44	0.31	0.76
Average	11.79	11.72	11.73	11.48	11.40	0.17	11.62	1.07	0.95	0.66	0.73	0.56	0.21	0.80

1(B): CIRCULAR TRACK

Subject	Time (s)							Error (dimensionless)						
	T1	T2	T3	T4	T5	SD	Tave	E1	E2	E3	E4	E5	SD	Eave
A	23.59	23.27	23.63	23.86	23.31	0.24	23.53	5.13	1.83	1.72	1.61	1.82	1.52	2.42
B	24.02	23.48	23.30	23.42	23.14	0.33	23.47	4.58	4.68	4.43	2.60	3.15	0.95	3.89
C	33.86	25.81	23.69	25.48	23.17	4.32	26.40	1.92	1.94	2.59	2.17	3.37	0.61	2.40
D	24.24	24.33	25.44	23.89	23.81	0.65	24.34	1.84	1.82	2.10	2.29	1.73	0.23	1.96
E	22.72	22.88	23.09	22.78	22.81	0.14	22.86	2.65	2.05	2.34	1.92	1.87	0.33	2.17
F	33.33	32.44	28.53	26.95	25.11	3.53	29.27	2.03	1.87	2.12	2.15	2.07	0.11	2.05
G	27.19	25.59	24.41	24.17	23.77	1.39	25.02	2.34	1.86	1.71	1.96	2.22	0.26	2.02
H	24.50	23.66	23.77	23.84	23.77	0.34	23.91	1.79	1.80	1.86	1.73	2.11	0.15	1.86
I	38.53	24.83	28.47	37.30	27.84	6.12	31.39	1.99	2.49	2.09	2.13	2.11	0.19	2.16
J	24.92	24.30	24.19	23.94	23.95	0.40	24.26	2.02	2.07	1.91	1.88	2.11	0.10	2.00
K	23.80	23.38	23.46	23.64	23.23	0.23	23.50	4.85	3.25	3.07	2.10	2.48	1.06	3.15
L	29.05	25.07	24.56	24.69	23.49	2.14	25.37	1.88	1.88	2.35	2.23	2.55	0.30	2.18
M	28.02	27.66	25.81	24.87	23.96	1.75	26.06	2.34	1.96	2.23	2.04	1.97	0.17	2.11
N	25.84	24.63	24.09	24.01	23.77	0.83	24.47	2.07	1.83	1.78	1.84	2.16	0.17	1.94
O	31.73	24.56	26.33	30.62	25.90	3.15	27.83	2.00	2.28	2.00	2.01	2.11	0.12	2.08
P	28.46	27.85	26.08	25.41	24.21	1.75	26.40	3.58	1.85	1.92	1.88	1.95	0.75	2.23
Q	25.60	24.54	23.85	23.80	23.45	0.85	24.25	3.46	3.27	3.07	2.28	2.68	0.47	2.95
R	29.18	24.73	23.73	24.66	23.47	2.32	25.15	1.86	1.87	2.22	1.95	2.74	0.37	2.13
S	31.38	24.58	26.95	30.59	25.83	2.98	27.87	1.91	2.16	2.10	2.21	1.92	0.14	2.06
T	23.82	23.59	23.64	23.36	23.38	0.19	23.56	2.33	2.06	2.13	1.90	1.99	0.16	2.08
AVERAGE	27.69	25.06	24.85	25.56	24.07	1.36	25.45	2.63	2.24	2.29	2.04	2.26	0.21	2.29

1(C): ELLIPTICAL TRACK

Subject	Time (s)							Error (dimensionless)						
	T1	T2	T3	T4	T5	SD	T _{ave}	E1	E2	E3	E4	E5	SD	E _{ave}
A	25.56	25.61	25.59	25.36	25.48	0.10	25.52	2.00	1.52	1.24	1.31	1.54	0.30	1.52
B	25.53	25.56	25.81	25.86	25.47	0.18	25.65	2.85	3.05	2.54	2.34	2.58	0.28	2.67
C	26.08	25.41	25.56	25.56	25.48	0.26	25.62	1.82	1.91	1.48	1.80	1.82	0.17	1.77
D	36.39	30.97	31.09	34.16	29.13	2.89	32.35	2.03	1.68	1.58	1.98	1.82	0.19	1.82
E	25.44	25.34	26.89	25.39	25.49	0.66	25.71	1.40	1.63	1.75	1.76	1.60	0.14	1.63
F	36.66	33.20	29.06	27.36	27.08	4.14	30.67	2.00	1.88	1.82	1.84	2.05	0.10	1.92
G	25.73	25.88	25.92	25.63	25.94	0.13	25.82	1.90	1.54	1.61	1.99	1.47	0.23	1.70
H	25.66	25.53	25.75	25.33	25.69	0.17	25.59	2.11	2.18	2.67	2.62	2.32	0.25	2.38
I	31.78	26.95	27.13	26.70	26.69	2.20	27.85	2.26	2.09	1.93	2.05	2.32	0.16	2.13
J	26.50	26.52	26.61	27.00	26.67	0.20	26.66	1.62	1.76	2.20	1.76	1.86	0.22	1.84
K	25.55	25.59	25.70	25.61	25.48	0.08	25.58	2.42	2.28	1.89	1.83	2.06	0.25	2.10
L	31.23	28.19	28.33	29.86	27.30	1.56	28.98	1.93	1.80	1.53	1.89	1.82	0.16	1.79
M	31.05	29.27	27.98	26.38	26.28	2.02	28.19	1.70	1.75	1.79	1.80	1.82	0.05	1.77
N	25.70	25.70	25.84	25.48	25.81	0.14	25.70	2.00	1.86	2.14	2.31	1.89	0.19	2.04
O	29.14	26.73	26.87	26.85	26.68	1.06	27.25	1.94	1.92	2.06	1.91	2.09	0.09	1.98
P	31.11	29.41	27.33	26.36	26.28	2.10	28.10	2.00	1.70	1.53	1.57	1.79	0.19	1.72
Q	25.63	25.72	25.87	25.74	25.70	0.09	25.73	2.37	2.29	2.07	2.17	2.02	0.15	2.19
R	25.87	25.47	25.66	25.45	25.59	0.17	25.60	1.97	2.05	2.07	2.21	2.07	0.09	2.07
S	34.09	28.96	29.11	30.43	27.91	2.40	30.10	2.14	1.88	1.75	2.02	2.07	0.15	1.97
T	25.97	25.93	26.75	26.20	26.08	0.33	26.18	1.51	1.69	1.97	1.76	1.73	0.16	1.73
AVERAGE	28.53	27.10	26.94	26.83	26.31	0.83	27.14	2.00	1.92	1.88	1.95	1.94	0.04	1.94

1(D): SQUARE TRACK

Subject	Time (s)							Error (dimensionless)						
	T1	T2	T3	T4	T5	SD	Tave	E1	E2	E3	E4	E5	SD	Eave
A	30.11	31.14	30.02	30.59	30.52	0.45	30.48	2.75	2.22	2.91	2.05	3.31	0.51	2.65
B	36.95	31.66	30.94	30.31	30.42	2.79	32.06	2.93	3.67	3.45	3.03	2.65	0.41	3.15
C	29.59	28.27	27.00	27.16	26.14	1.33	27.63	4.67	5.20	2.90	3.42	2.98	1.04	3.83
D	55.70	46.11	46.13	44.14	43.83	4.88	47.18	1.90	1.64	2.03	2.20	2.05	0.21	1.96
E	27.05	28.38	27.09	26.91	28.16	0.69	27.52	3.22	2.94	2.93	2.95	3.17	0.14	3.04
F	37.42	39.11	34.94	38.98	36.20	1.80	37.33	1.90	2.05	2.75	1.59	2.29	0.43	2.12
G	30.33	33.36	30.55	30.73	30.88	1.24	31.17	4.90	3.08	2.99	2.63	3.80	0.90	3.48
H	28.44	37.17	32.59	30.28	29.66	3.45	31.63	2.68	2.64	3.34	2.40	2.48	0.37	2.71
I	29.58	29.94	29.02	29.24	29.59	0.36	29.47	3.87	2.83	3.51	2.59	2.38	0.63	3.03
J	30.38	26.52	33.34	37.14	31.16	3.91	31.71	2.48	5.05	3.44	2.01	2.07	1.28	3.01
K	33.53	31.40	30.48	30.45	30.47	1.33	31.27	2.84	2.94	3.18	2.54	2.98	0.23	2.90
L	42.65	37.19	36.56	35.65	34.98	3.05	37.41	3.29	3.42	2.46	2.81	2.51	0.44	2.90
M	32.23	33.74	31.02	32.95	32.18	1.01	32.42	2.56	2.50	2.84	2.27	2.73	0.22	2.58
N	29.38	35.27	31.57	30.51	30.27	2.30	31.40	3.79	2.86	3.17	2.51	3.14	0.47	3.09
O	29.98	28.23	31.18	33.19	30.38	1.81	30.59	3.18	3.94	3.47	2.30	2.23	0.75	3.02
P	33.77	35.13	32.48	34.79	33.36	1.08	33.90	2.33	2.14	2.83	1.82	2.80	0.43	2.38
Q	33.64	32.51	30.74	30.52	30.65	1.40	31.61	3.91	3.38	3.22	2.83	3.22	0.39	3.31
R	29.02	32.72	29.80	28.72	27.90	1.86	29.63	3.67	3.92	3.12	2.91	2.73	0.51	3.27
S	42.64	38.02	37.57	36.69	36.71	2.48	38.33	2.89	2.24	2.77	2.40	2.21	0.31	2.50
T	28.71	27.45	30.22	32.02	29.66	1.71	29.61	2.85	4.00	3.18	2.48	2.62	0.61	3.03
AVERAGE	33.55	33.16	32.16	32.55	31.65	0.76	32.62	3.13	3.13	3.02	2.49	2.72	0.29	2.90

1(E): TRIANGULAR TRACK

Subject	Time (s)							Error (dimensionless)						
	T1	T2	T3	T4	T5	SD	Tave	E1	E2	E3	E4	E5	SD	Eave
A	27.42	27.88	29.53	29.78	32.28	1.92	29.38	3.93	2.40	2.29	2.26	1.75	0.82	2.53
B	25.55	26.06	26.48	28.47	28.86	1.49	27.08	3.95	3.73	3.27	3.86	3.49	0.28	3.66
C	21.36	19.74	20.45	22.42	19.97	1.11	20.79	7.26	5.68	5.55	5.31	8.71	1.45	6.50
D	47.02	33.14	37.03	40.13	41.38	5.16	39.74	2.11	2.50	2.49	2.57	2.29	0.19	2.39
E	20.99	22.48	23.75	24.39	25.39	1.71	23.40	5.50	3.77	2.85	2.55	1.97	1.38	3.33
F	31.28	28.11	31.00	29.95	28.08	1.53	29.68	3.03	3.80	2.40	2.68	2.61	0.55	2.90
G	27.06	31.25	27.69	24.14	25.73	2.65	27.18	3.65	3.18	3.93	4.83	4.82	0.73	4.08
H	26.13	27.41	27.59	25.11	28.09	1.22	26.87	2.67	2.70	2.90	3.93	3.07	0.52	3.06
I	24.73	23.66	25.95	24.45	23.99	0.88	24.56	3.71	5.05	4.38	5.07	4.11	0.59	4.46
J	24.61	23.67	24.55	23.81	24.94	0.55	24.32	3.44	3.63	2.59	3.98	2.86	0.57	3.30
K	26.48	26.97	28.01	29.12	30.57	1.66	28.23	3.94	3.06	2.78	3.06	2.62	0.51	3.09
L	34.19	26.44	28.74	31.27	30.67	2.90	30.26	4.68	4.09	4.02	3.94	5.50	0.66	4.45
M	26.13	25.30	27.38	27.17	26.73	0.84	26.54	4.27	3.78	2.63	2.62	2.29	0.86	3.12
N	26.59	29.33	27.64	24.63	26.91	1.71	27.02	3.16	2.94	3.41	4.38	3.94	0.59	3.57
O	24.67	23.66	25.25	24.13	24.46	0.59	24.44	3.57	4.34	3.49	4.53	3.49	0.51	3.88
P	29.35	27.99	30.27	29.87	30.18	0.93	29.53	3.48	3.10	2.35	2.47	2.18	0.55	2.72
Q	26.30	28.66	27.09	26.30	27.30	0.96	27.13	3.80	3.45	3.60	4.35	4.15	0.37	3.87
R	23.74	23.57	24.02	23.77	24.03	0.20	23.83	4.97	4.19	4.22	4.62	5.89	0.70	4.78
S	35.88	28.40	31.49	32.29	32.68	2.68	32.15	2.91	3.77	3.43	3.82	3.20	0.39	3.43
T	22.80	23.08	24.15	24.10	25.16	0.95	23.86	4.47	3.70	2.72	3.27	2.41	0.81	3.31
AVERAGE	27.61	26.34	27.40	27.27	27.87	0.58	27.30	3.92	3.64	3.26	3.70	3.57	0.24	3.62

APPENDIX 2: NORMALIZED DATA FOR EGC

2(A): STRAIGHT TRACK

Subject	Time (s)					Error (dimensionless)				
	T1	T2	T3	T4	T5	E1	E2	E3	E4	E5
A	0.25	0.27	0.31	0.28	0.26	0.79	0.12	0.12	0.11	0.12
B	0.26	0.26	0.26	0.26	0.26	0.51	0.67	0.59	0.65	0.33
C	0.25	0.25	0.27	0.26	0.26	0.72	0.79	0.63	0.66	0.65
D	0.30	0.31	0.32	0.29	0.29	0.60	0.26	0.42	0.70	0.53
E	0.25	0.25	0.26	0.25	0.26	0.73	0.71	0.12	0.12	0.12
F	0.45	0.42	0.35	0.30	0.28	0.56	0.68	0.11	0.12	0.11
G	0.28	0.27	0.27	0.26	0.27	0.33	0.63	0.27	0.50	0.11
H	0.27	0.27	0.27	0.26	0.26	0.82	0.70	0.62	0.11	0.61
I	0.25	0.27	0.26	0.26	0.26	0.44	0.55	0.67	0.48	0.11
J	0.32	0.30	0.33	0.34	0.32	0.65	0.54	0.38	0.69	0.29
K	0.26	0.27	0.29	0.27	0.26	0.70	0.52	0.44	0.50	0.24
L	0.28	0.28	0.30	0.28	0.27	0.67	0.67	0.55	0.68	0.60
M	0.37	0.35	0.31	0.28	0.27	0.67	0.69	0.12	0.12	0.12
N	0.28	0.27	0.27	0.26	0.26	0.72	0.67	0.50	0.36	0.46
O	0.29	0.29	0.30	0.30	0.29	0.57	0.55	0.57	0.61	0.21
P	0.37	0.36	0.33	0.29	0.27	0.71	0.52	0.12	0.12	0.11
Q	0.27	0.26	0.27	0.26	0.26	0.43	0.65	0.47	0.59	0.24
R	0.26	0.26	0.27	0.26	0.26	0.78	0.75	0.63	0.51	0.63
S	0.28	0.29	0.29	0.27	0.27	0.53	0.44	0.58	0.62	0.38
T	0.29	0.28	0.30	0.30	0.29	0.70	0.64	0.27	0.54	0.21

Note: $T_B = 8.3$ seconds, $E_s = 0.35$.

2(B): CIRCULAR TRACK

Subject	Time (s)					Error (dimensionless)				
	T1	T2	T3	T4	T5	E1	E2	E3	E4	E5
A	0.33	0.32	0.33	0.34	0.32	0.69	0.12	0.07	0.00	0.12
B	0.34	0.33	0.32	0.33	0.32	0.65	0.66	0.64	0.39	0.49
C	0.53	0.39	0.33	0.38	0.32	0.17	0.17	0.38	0.26	0.53
D	0.35	0.35	0.38	0.34	0.34	0.13	0.12	0.24	0.30	0.08
E	0.30	0.31	0.32	0.31	0.31	0.40	0.22	0.32	0.17	0.14
F	0.53	0.51	0.45	0.41	0.37	0.21	0.15	0.24	0.26	0.23
G	0.42	0.38	0.35	0.35	0.34	0.32	0.14	0.06	0.18	0.28
H	0.36	0.33	0.34	0.34	0.34	0.11	0.11	0.14	0.07	0.24
I	0.59	0.36	0.44	0.58	0.43	0.20	0.36	0.24	0.25	0.24
J	0.37	0.35	0.35	0.34	0.34	0.21	0.23	0.16	0.15	0.24
K	0.34	0.32	0.33	0.33	0.32	0.67	0.51	0.48	0.24	0.36
L	0.46	0.37	0.36	0.36	0.33	0.15	0.15	0.32	0.28	0.37
M	0.44	0.43	0.39	0.36	0.34	0.32	0.18	0.28	0.21	0.19
N	0.39	0.36	0.34	0.34	0.34	0.23	0.13	0.10	0.13	0.26
O	0.50	0.36	0.40	0.48	0.39	0.20	0.30	0.20	0.20	0.24
P	0.44	0.43	0.39	0.38	0.35	0.55	0.13	0.17	0.15	0.18
Q	0.38	0.36	0.34	0.34	0.33	0.54	0.51	0.48	0.30	0.40
R	0.46	0.36	0.33	0.36	0.33	0.14	0.14	0.28	0.18	0.42
S	0.50	0.36	0.41	0.48	0.39	0.16	0.26	0.24	0.28	0.17
T	0.34	0.33	0.33	0.32	0.32	0.31	0.22	0.25	0.16	0.20

Note: $T_B = 15.8$ seconds, $E_s = 1.60$.

2(C): ELLIPTICAL TRACK

Subject	Time (s)					Error (dimensionless)				
	T1	T2	T3	T4	T5	E1	E2	E3	E4	E5
A	0.28	0.29	0.28	0.28	0.28	0.40	0.21	0.03	0.08	0.22
B	0.28	0.28	0.29	0.29	0.28	0.58	0.61	0.53	0.49	0.53
C	0.30	0.28	0.28	0.28	0.28	0.34	0.37	0.19	0.33	0.34
D	0.50	0.41	0.41	0.46	0.37	0.41	0.29	0.24	0.39	0.34
E	0.28	0.28	0.32	0.28	0.28	0.15	0.26	0.31	0.32	0.25
F	0.50	0.45	0.37	0.33	0.32	0.40	0.36	0.34	0.35	0.41
G	0.29	0.29	0.29	0.29	0.29	0.37	0.22	0.25	0.40	0.18
H	0.29	0.28	0.29	0.28	0.29	0.43	0.45	0.55	0.54	0.48
I	0.42	0.32	0.33	0.31	0.31	0.47	0.43	0.38	0.41	0.48
J	0.31	0.31	0.31	0.32	0.31	0.26	0.32	0.45	0.32	0.35
K	0.28	0.28	0.29	0.29	0.28	0.50	0.47	0.36	0.34	0.42
L	0.41	0.35	0.35	0.39	0.33	0.38	0.33	0.21	0.37	0.34
M	0.41	0.37	0.35	0.31	0.30	0.29	0.32	0.33	0.33	0.34
N	0.29	0.29	0.29	0.28	0.29	0.40	0.35	0.44	0.48	0.37
O	0.37	0.32	0.32	0.32	0.31	0.38	0.38	0.42	0.37	0.43
P	0.41	0.38	0.33	0.31	0.30	0.40	0.30	0.21	0.24	0.33
Q	0.29	0.29	0.29	0.29	0.29	0.49	0.48	0.42	0.45	0.41
R	0.29	0.28	0.29	0.28	0.28	0.39	0.41	0.42	0.46	0.42
S	0.46	0.37	0.37	0.40	0.34	0.44	0.36	0.32	0.40	0.42
T	0.30	0.29	0.32	0.30	0.30	0.21	0.29	0.39	0.32	0.31

Note: $T_B = 18.3$ seconds, $E_s = 1.20$.

2(D): SQUARE TRACK

Subject	Time (s)					Error (dimensionless)				
	T1	T2	T3	T4	T5	E1	E2	E3	E4	E5
A	0.25	0.28	0.25	0.26	0.26	0.44	0.30	0.47	0.24	0.53
B	0.39	0.29	0.27	0.26	0.26	0.47	0.58	0.55	0.49	0.41
C	0.24	0.20	0.17	0.17	0.14	0.67	0.70	0.47	0.55	0.48
D	0.60	0.51	0.51	0.49	0.49	0.19	0.06	0.23	0.30	0.24
E	0.17	0.21	0.17	0.16	0.20	0.52	0.47	0.47	0.47	0.51
F	0.40	0.42	0.36	0.42	0.38	0.19	0.25	0.44	0.03	0.32
G	0.26	0.33	0.26	0.27	0.27	0.68	0.50	0.48	0.41	0.59
H	0.21	0.39	0.31	0.26	0.24	0.42	0.41	0.54	0.35	0.37
I	0.24	0.25	0.22	0.23	0.24	0.60	0.45	0.56	0.40	0.35
J	0.26	0.15	0.33	0.39	0.28	0.37	0.69	0.55	0.23	0.25
K	0.33	0.28	0.26	0.26	0.26	0.45	0.47	0.51	0.39	0.48
L	0.47	0.39	0.38	0.37	0.36	0.53	0.55	0.37	0.45	0.38
M	0.30	0.33	0.27	0.32	0.30	0.39	0.38	0.45	0.32	0.43
N	0.23	0.36	0.29	0.26	0.26	0.59	0.46	0.51	0.38	0.51
O	0.25	0.20	0.28	0.32	0.26	0.51	0.61	0.55	0.33	0.30
P	0.33	0.36	0.31	0.35	0.33	0.33	0.27	0.45	0.15	0.45
Q	0.33	0.31	0.27	0.26	0.27	0.60	0.54	0.52	0.45	0.52
R	0.22	0.31	0.24	0.22	0.19	0.58	0.60	0.50	0.47	0.43
S	0.47	0.41	0.40	0.39	0.39	0.46	0.31	0.44	0.35	0.30
T	0.22	0.18	0.26	0.30	0.24	0.46	0.61	0.51	0.37	0.41

Note: $T_B = 22.5$ seconds, $E_s = 1.55$.

2(E): TRIANGULAR TRACK

Subject	Time (s)					Error (dimensionless)				
	T1	T2	T3	T4	T5	E1	E2	E3	E4	E5
A	0.39	0.40	0.43	0.44	0.48	0.57	0.29	0.26	0.25	0.03
B	0.35	0.36	0.37	0.41	0.42	0.57	0.54	0.48	0.56	0.51
C	0.22	0.15	0.18	0.26	0.16	0.77	0.70	0.69	0.68	0.80
D	0.64	0.50	0.55	0.58	0.60	0.19	0.32	0.32	0.34	0.26
E	0.20	0.26	0.30	0.32	0.34	0.69	0.55	0.40	0.33	0.14
F	0.47	0.41	0.46	0.44	0.41	0.44	0.55	0.29	0.37	0.35
G	0.38	0.47	0.40	0.31	0.35	0.53	0.47	0.57	0.65	0.65
H	0.36	0.39	0.39	0.33	0.41	0.36	0.37	0.41	0.57	0.45
I	0.32	0.29	0.36	0.32	0.30	0.54	0.66	0.61	0.66	0.59
J	0.32	0.29	0.32	0.30	0.33	0.51	0.53	0.34	0.57	0.41
K	0.37	0.38	0.40	0.43	0.45	0.57	0.45	0.39	0.44	0.35
L	0.51	0.37	0.42	0.47	0.46	0.64	0.58	0.58	0.57	0.69
M	0.36	0.34	0.39	0.39	0.38	0.60	0.55	0.35	0.35	0.26
N	0.37	0.43	0.40	0.32	0.38	0.46	0.42	0.50	0.61	0.57
O	0.32	0.29	0.34	0.31	0.32	0.52	0.61	0.51	0.62	0.51
P	0.43	0.40	0.45	0.44	0.45	0.51	0.45	0.28	0.31	0.22
Q	0.37	0.42	0.38	0.37	0.39	0.55	0.51	0.53	0.61	0.59
R	0.30	0.29	0.30	0.30	0.31	0.66	0.59	0.60	0.63	0.71
S	0.53	0.41	0.47	0.48	0.49	0.42	0.55	0.51	0.56	0.47
T	0.27	0.28	0.31	0.31	0.34	0.62	0.54	0.38	0.48	0.30

Note: $T_B = 16.7$ seconds, $E_s = 1.70$.

APPENDIX 3: RESULTS FOR STC

3(A): STC1

Subject	Time (s)							Error (dimensionless)						
	T1	T2	T3	T4	T5	SD	Tave	E1	E2	E3	E4	E5	SD	Eave
A	24.14	22.83	26.14	24.95	19.39	2.59	23.49	5.02	5.39	4.33	3.86	3.75	0.72	4.47
B	17.22	21.33	18.05	17.16	14.34	2.50	17.62	12.78	7.79	4.44	4.65	8.05	3.38	7.54
C	14.91	11.25	11.59	11.67	12.14	1.48	12.31	14.05	5.42	3.54	3.42	11.31	4.85	7.55
D	35.69	15.84	12.56	12.98	23.95	9.79	20.21	8.71	6.82	9.47	9.31	27.59	8.57	12.38
E	11.53	12.92	13.24	13.03	12.98	0.69	12.74	4.05	3.56	3.26	3.46	2.87	0.43	3.44
F	16.91	22.86	18.09	15.27	15.88	3.03	17.80	13.10	5.79	5.62	6.64	5.41	3.27	7.31
G	14.39	14.39	17.55	13.98	19.84	2.57	16.03	8.62	5.86	5.42	6.39	4.41	1.57	6.14
H	18.99	20.73	20.56	15.44	24.92	3.42	20.13	8.47	5.32	6.04	6.33	3.95	1.65	6.02
I	20.34	14.72	13.17	16.36	13.09	3.00	15.54	8.17	6.71	12.04	5.47	5.34	2.76	7.55
J	11.95	14.88	12.95	11.83	12.03	1.28	12.73	8.57	5.06	5.36	4.55	5.61	1.58	5.83
K	20.68	22.08	22.09	21.05	16.87	2.15	20.55	8.90	6.59	4.38	4.26	5.90	1.90	6.01
L	25.30	13.55	12.08	12.33	18.05	5.59	16.26	11.38	6.12	6.51	6.36	19.45	5.74	9.96
M	14.22	17.89	15.66	14.15	14.43	1.59	15.27	8.57	4.67	4.44	5.05	4.14	1.82	5.38
N	16.69	17.56	19.06	14.71	22.38	2.87	18.08	8.54	5.59	5.73	6.36	4.18	1.59	6.08
O	16.15	14.80	13.06	14.09	12.56	1.42	14.13	8.37	5.88	8.70	5.01	5.47	1.72	6.69
P	20.52	22.84	22.12	20.11	17.63	2.02	20.65	9.06	5.59	4.97	5.25	4.58	1.81	5.89
Q	15.80	17.86	17.80	15.57	17.09	1.08	16.83	10.70	6.83	4.93	5.52	6.23	2.27	6.84
R	16.95	15.99	16.08	13.55	18.53	1.81	16.22	11.26	5.37	4.79	4.87	7.63	2.76	6.78
S	28.02	15.28	12.87	14.67	18.52	6.03	17.87	8.44	6.77	10.76	7.39	16.46	3.94	9.96
T	11.74	13.90	13.09	12.43	12.51	0.81	12.73	6.31	4.31	4.31	4.00	4.24	0.94	4.63
AVERAGE	18.61	17.18	16.39	15.27	16.86	1.22	16.86	9.15	5.77	5.95	5.41	7.83	1.61	6.82

3(B): STC2

Subject	Time (s)							Error (dimensionless)						
	T1	T2	T3	T4	T5	SD	Tave	E1	E2	E3	E4	E5	SD	Eave
A	13.67	15.14	13.56	15.08	15.47	0.90	14.58	3.35	3.68	1.86	2.67	4.73	1.08	3.26
B	11.58	11.38	11.64	11.30	11.31	0.16	11.44	3.12	3.16	2.58	2.25	1.89	0.55	2.60
C	11.31	11.34	11.38	11.45	11.42	0.06	11.38	1.70	3.82	2.10	2.73	1.62	0.91	2.39
D	17.56	14.55	12.36	13.88	12.49	2.11	14.17	1.22	7.54	4.81	6.08	2.81	2.52	4.49
E	13.13	11.50	11.42	11.22	11.36	0.79	11.73	1.89	2.52	1.33	1.35	1.19	0.55	1.65
F	18.02	15.05	14.81	15.28	13.22	1.73	15.28	1.24	1.95	1.34	1.35	1.50	0.28	1.48
G	11.41	11.64	12.05	12.61	12.19	0.47	11.98	4.97	4.65	2.25	3.06	2.54	1.24	3.50
H	18.91	13.39	11.88	14.91	14.36	2.62	14.69	1.51	3.07	2.52	4.08	1.99	1.00	2.63
I	13.41	11.94	12.05	11.75	11.67	0.71	12.16	3.40	5.53	3.02	3.28	2.55	1.15	3.55
J	12.02	12.44	12.16	12.22	11.67	0.28	12.10	4.07	6.67	2.29	5.15	1.49	2.10	3.93
K	12.63	13.26	12.60	13.19	13.39	0.37	13.01	3.24	3.42	2.22	2.46	3.31	0.55	2.93
L	14.44	12.95	11.87	12.66	11.95	1.04	12.77	1.46	5.68	3.46	4.41	2.22	1.69	3.44
M	15.57	13.27	13.12	13.25	12.29	1.23	13.50	1.57	2.23	1.33	1.35	1.34	0.39	1.57
N	15.16	12.52	11.96	13.76	13.27	1.23	13.33	3.24	3.86	2.39	3.57	2.26	0.71	3.06
O	12.71	12.19	12.10	11.98	11.67	0.38	12.13	3.73	6.10	2.65	4.21	2.02	1.58	3.74
P	15.84	15.09	14.19	15.18	14.34	0.67	14.93	2.30	2.81	1.60	2.01	3.11	0.61	2.37
Q	11.49	11.51	11.84	11.95	11.75	0.20	11.71	4.05	3.91	2.41	2.65	2.21	0.87	3.05
R	15.11	12.37	11.63	13.18	12.89	1.30	13.03	1.60	3.44	2.31	3.40	1.80	0.87	2.51
S	15.49	13.24	12.20	12.81	12.08	1.38	13.16	2.31	6.54	3.91	4.68	2.68	1.70	4.02
T	12.57	11.97	11.79	11.72	11.52	0.40	11.91	2.98	4.59	1.81	3.25	1.34	1.28	2.79
AVERAGE	14.10	12.84	12.33	12.97	12.52	0.69	12.95	2.65	4.26	2.41	3.20	2.23	0.82	2.95

3(C): STC3

Subject	Time (s)							Error (dimensionless)						
	T1	T2	T3	T4	T5	SD	Tave	E1	E2	E3	E4	E5	SD	Eave
A	51.63	54.13	64.52	46.98	37.02	10.05	50.85	8.06	9.20	7.50	9.08	8.16	0.72	8.40
B	45.00	40.38	35.05	35.53	35.95	4.27	38.38	9.17	8.52	6.84	7.69	4.77	1.71	7.40
C	30.84	32.97	33.64	38.89	34.25	2.96	34.12	24.41	11.29	6.91	7.97	5.35	7.71	11.19
D	42.95	41.75	31.64	45.64	30.53	6.93	38.50	10.91	8.02	17.16	6.43	18.58	5.43	12.22
E	48.39	45.27	38.72	37.02	36.38	5.37	41.15	3.12	2.86	3.44	3.68	3.29	0.31	3.28
F	41.77	45.25	40.92	39.02	40.28	2.35	41.45	7.86	5.21	4.29	3.94	3.76	1.69	5.01
G	35.31	32.56	33.50	38.42	43.27	4.34	36.61	10.63	9.97	11.41	6.52	5.35	2.67	8.78
H	47.59	41.97	31.22	36.67	36.00	6.27	38.69	7.51	7.31	9.18	7.89	9.11	0.89	8.20
I	41.70	35.75	30.86	31.09	31.63	4.64	34.21	5.69	7.05	8.94	13.51	8.05	2.97	8.65
J	34.77	41.05	41.58	41.33	48.49	4.86	41.44	8.47	5.68	4.93	5.19	4.62	1.55	5.78
K	48.31	47.25	49.78	41.26	36.49	5.58	44.62	8.61	8.86	7.17	8.39	6.46	1.03	7.90
L	36.90	37.36	32.64	42.27	32.39	4.05	36.31	17.66	9.65	12.03	7.20	11.96	3.88	11.70
M	45.08	45.26	39.82	38.02	38.33	3.60	41.30	5.49	4.04	3.86	3.81	3.52	0.77	4.14
N	41.45	37.27	32.36	37.55	39.63	3.41	37.65	9.07	8.64	10.29	7.21	7.23	1.31	8.49
O	38.24	38.40	36.22	36.21	40.06	1.63	37.82	7.08	6.36	6.94	9.35	6.33	1.24	7.21
P	46.70	49.69	52.72	43.00	38.65	5.53	46.15	7.96	7.20	5.89	6.51	5.96	0.88	6.71
Q	40.16	36.47	34.27	36.98	39.61	2.41	37.50	9.90	9.24	9.12	7.10	5.06	1.99	8.09
R	39.22	37.47	32.43	37.78	35.13	2.66	36.40	15.96	9.30	8.04	7.93	7.23	3.58	9.69
S	42.33	38.75	31.25	38.37	31.08	4.98	36.35	8.30	7.53	13.05	9.97	13.31	2.66	10.43
T	41.58	43.16	40.15	39.17	42.43	1.63	41.30	5.79	4.27	4.19	4.43	3.95	0.73	4.53
AVERAGE	42.00	41.11	38.16	39.06	37.38	1.95	39.54	9.58	7.51	8.06	7.19	7.10	1.02	7.89

3(D): STC4

Subject	Time (s)							Error (dimensionless)						
	T1	T2	T3	T4	T5	SD	Tave	E1	E2	E3	E4	E5	SD	Eave
A	34.11	32.03	33.97	31.14	34.70	1.52	33.19	2.37	3.86	1.97	4.17	5.26	1.35	3.53
B	31.03	30.53	31.33	30.88	29.47	0.72	30.65	3.72	2.60	2.43	3.35	2.47	0.59	2.91
C	30.30	31.33	30.19	30.94	30.69	0.47	30.69	2.81	2.88	4.12	3.32	3.67	0.55	3.36
D	36.92	39.20	29.58	46.84	47.64	7.48	40.04	3.09	3.36	4.98	2.53	4.08	0.95	3.61
E	29.09	31.69	30.86	31.05	31.80	1.09	30.90	2.40	2.44	1.99	2.15	2.36	0.19	2.27
F	39.58	36.02	35.75	35.53	36.61	1.66	36.70	2.46	2.39	2.03	1.98	2.60	0.28	2.29
G	31.84	31.08	30.81	30.44	29.59	0.83	30.75	2.93	7.33	2.09	5.41	2.58	2.23	4.07
H	31.80	32.52	31.73	37.86	40.81	4.15	34.94	5.38	4.19	4.55	3.86	2.72	0.97	4.14
I	28.83	29.75	28.47	29.80	29.56	0.60	29.28	3.79	7.22	5.03	4.84	4.67	1.27	5.11
J	30.50	31.56	32.50	31.48	33.64	1.19	31.94	2.16	5.11	2.03	2.37	3.91	1.35	3.12
K	32.57	31.28	32.65	31.01	32.09	0.75	31.92	3.05	3.23	2.20	3.76	3.87	0.67	3.22
L	33.61	35.27	29.88	38.89	39.16	3.87	35.36	2.95	3.12	4.55	2.92	3.87	0.71	3.48
M	34.34	33.85	33.30	33.29	34.20	0.49	33.80	2.43	2.42	2.01	2.06	2.48	0.23	2.28
N	31.82	31.80	31.27	34.15	35.20	1.72	32.85	4.15	5.76	3.32	4.64	2.65	1.20	4.10
O	29.66	30.66	30.48	30.64	31.60	0.69	30.61	2.98	6.17	3.53	3.60	4.29	1.24	4.11
P	36.84	34.02	34.86	33.34	35.66	1.37	34.94	2.42	3.13	2.00	3.08	3.93	0.74	2.91
Q	31.44	30.80	31.07	30.66	29.53	0.72	30.70	3.33	4.97	2.26	4.38	2.53	1.17	3.49
R	31.05	31.92	30.96	34.40	35.75	2.15	32.82	4.09	3.53	4.34	3.59	3.19	0.46	3.75
S	32.88	34.48	29.02	38.32	38.60	4.00	34.66	3.44	5.29	5.01	3.68	4.38	0.80	4.36
T	29.80	31.63	31.68	31.27	32.72	1.06	31.42	2.28	3.78	2.01	2.26	3.14	0.74	2.69
AVERAGE	32.40	32.57	31.52	33.60	34.45	1.14	32.91	3.11	4.14	3.12	3.40	3.43	0.42	3.44

APPENDIX 4: NORMALIZED DATA FOR STC

4(A): STC1

Subject	Time (s)					Error (dimensionless)				
	T1	T2	T3	T4	T5	E1	E2	E3	E4	E5
A	0.66	0.64	0.68	0.67	0.57	0.93	0.94	0.92	0.91	0.91
B	0.52	0.61	0.54	0.52	0.42	0.97	0.96	0.92	0.92	0.96
C	0.44	0.26	0.28	0.29	0.32	0.98	0.94	0.90	0.90	0.97
D	0.77	0.48	0.34	0.36	0.65	0.96	0.95	0.96	0.96	0.99
E	0.28	0.36	0.37	0.36	0.36	0.91	0.90	0.89	0.90	0.88
F	0.51	0.64	0.54	0.46	0.48	0.97	0.94	0.94	0.95	0.94
G	0.42	0.42	0.53	0.41	0.58	0.96	0.94	0.94	0.95	0.92
H	0.56	0.60	0.60	0.46	0.67	0.96	0.93	0.94	0.94	0.91
I	0.59	0.44	0.37	0.49	0.37	0.96	0.95	0.97	0.94	0.93
J	0.31	0.44	0.36	0.30	0.31	0.96	0.93	0.93	0.92	0.94
K	0.60	0.62	0.62	0.61	0.51	0.96	0.95	0.92	0.92	0.94
L	0.67	0.39	0.31	0.33	0.54	0.97	0.94	0.95	0.95	0.98
M	0.42	0.54	0.47	0.41	0.42	0.96	0.93	0.92	0.93	0.92
N	0.50	0.53	0.56	0.44	0.63	0.96	0.94	0.94	0.94	0.92
O	0.49	0.44	0.36	0.41	0.34	0.96	0.94	0.96	0.93	0.94
P	0.60	0.64	0.62	0.59	0.53	0.96	0.94	0.93	0.93	0.92
Q	0.47	0.54	0.53	0.47	0.51	0.97	0.95	0.93	0.94	0.94
R	0.51	0.48	0.48	0.39	0.55	0.97	0.93	0.93	0.93	0.95
S	0.70	0.46	0.35	0.43	0.55	0.96	0.95	0.97	0.95	0.98
T	0.29	0.40	0.37	0.33	0.34	0.94	0.92	0.92	0.91	0.92

Note: $T_B = 8.3$ seconds, $E_s = 0.35$.

4(B): STC2

Subject	Time (s)					Error (dimensionless)				
	T1	T2	T3	T4	T5	E1	E2	E3	E4	E5
A	0.39	0.45	0.39	0.45	0.46	0.90	0.90	0.81	0.87	0.93
B	0.28	0.27	0.29	0.27	0.27	0.89	0.89	0.86	0.84	0.81
C	0.27	0.27	0.27	0.28	0.27	0.79	0.91	0.83	0.87	0.78
D	0.53	0.43	0.33	0.40	0.34	0.71	0.95	0.93	0.94	0.88
E	0.37	0.28	0.27	0.26	0.27	0.81	0.86	0.74	0.74	0.71
F	0.54	0.45	0.44	0.46	0.37	0.72	0.82	0.74	0.74	0.77
G	0.27	0.29	0.31	0.34	0.32	0.93	0.92	0.84	0.89	0.86
H	0.56	0.38	0.30	0.44	0.42	0.77	0.89	0.86	0.91	0.82
I	0.38	0.30	0.31	0.29	0.29	0.90	0.94	0.88	0.89	0.86
J	0.31	0.33	0.32	0.32	0.29	0.91	0.95	0.85	0.93	0.77
K	0.34	0.37	0.34	0.37	0.38	0.89	0.90	0.84	0.86	0.89
L	0.43	0.36	0.30	0.34	0.31	0.76	0.94	0.90	0.92	0.84
M	0.47	0.37	0.37	0.37	0.32	0.78	0.84	0.74	0.74	0.74
N	0.45	0.34	0.31	0.40	0.37	0.89	0.91	0.85	0.90	0.85
O	0.35	0.32	0.31	0.31	0.29	0.91	0.94	0.87	0.92	0.83
P	0.48	0.45	0.41	0.45	0.42	0.85	0.88	0.78	0.83	0.89
Q	0.28	0.28	0.30	0.31	0.29	0.91	0.91	0.85	0.87	0.84
R	0.45	0.33	0.29	0.37	0.36	0.78	0.90	0.85	0.90	0.81
S	0.46	0.37	0.32	0.35	0.31	0.85	0.95	0.91	0.93	0.87
T	0.34	0.31	0.30	0.29	0.28	0.88	0.92	0.81	0.89	0.74

Note: $T_B = 8.3$ seconds, $E_s = 0.35$.

4(C): STC3

Subject	Time (s)					Error (dimensionless)				
	T1	T2	T3	T4	T5	E1	E2	E3	E4	E5
A	0.65	0.66	0.72	0.61	0.51	0.85	0.87	0.84	0.87	0.85
B	0.59	0.55	0.48	0.48	0.49	0.87	0.86	0.82	0.84	0.75
C	0.41	0.44	0.46	0.53	0.47	0.95	0.89	0.83	0.85	0.78
D	0.57	0.56	0.42	0.60	0.40	0.89	0.85	0.93	0.81	0.94
E	0.62	0.60	0.53	0.51	0.50	0.61	0.58	0.65	0.67	0.64
F	0.56	0.60	0.55	0.53	0.55	0.85	0.77	0.72	0.70	0.68
G	0.48	0.44	0.45	0.52	0.58	0.89	0.88	0.89	0.82	0.78
H	0.62	0.56	0.41	0.50	0.49	0.84	0.84	0.87	0.85	0.87
I	0.56	0.49	0.41	0.41	0.42	0.79	0.83	0.87	0.91	0.85
J	0.47	0.55	0.56	0.56	0.62	0.86	0.79	0.76	0.77	0.74
K	0.62	0.61	0.63	0.56	0.50	0.86	0.86	0.83	0.86	0.81
L	0.50	0.51	0.44	0.57	0.44	0.93	0.88	0.90	0.83	0.90
M	0.59	0.60	0.54	0.52	0.52	0.78	0.70	0.69	0.68	0.66
N	0.56	0.51	0.43	0.51	0.54	0.87	0.86	0.88	0.83	0.83
O	0.52	0.52	0.49	0.49	0.54	0.83	0.81	0.83	0.87	0.81
P	0.61	0.63	0.65	0.57	0.53	0.85	0.83	0.80	0.82	0.80
Q	0.54	0.50	0.47	0.51	0.54	0.88	0.87	0.87	0.83	0.76
R	0.53	0.51	0.44	0.52	0.48	0.92	0.87	0.85	0.85	0.83
S	0.57	0.53	0.41	0.52	0.41	0.86	0.84	0.91	0.88	0.91
T	0.56	0.58	0.54	0.53	0.57	0.79	0.72	0.71	0.73	0.70

Note: $T_B = 18.3$ seconds, $E_s = 1.20$.

4(D): STC4

Subject	Time (s)					Error (dimensionless)				
	T1	T2	T3	T4	T5	E1	E2	E3	E4	E5
A	0.34	0.30	0.34	0.28	0.35	0.35	0.60	0.21	0.63	0.71
B	0.27	0.26	0.28	0.27	0.24	0.58	0.40	0.36	0.54	0.37
C	0.26	0.28	0.25	0.27	0.27	0.45	0.46	0.62	0.53	0.58
D	0.39	0.43	0.24	0.52	0.53	0.50	0.54	0.69	0.39	0.62
E	0.23	0.29	0.27	0.28	0.29	0.36	0.37	0.22	0.28	0.34
F	0.43	0.38	0.37	0.37	0.39	0.37	0.35	0.24	0.22	0.40
G	0.29	0.28	0.27	0.26	0.24	0.47	0.79	0.26	0.71	0.40
H	0.29	0.31	0.29	0.41	0.45	0.71	0.63	0.66	0.60	0.43
I	0.22	0.24	0.21	0.24	0.24	0.59	0.79	0.69	0.68	0.67
J	0.26	0.29	0.31	0.29	0.33	0.28	0.70	0.24	0.35	0.60
K	0.31	0.28	0.31	0.27	0.30	0.49	0.52	0.29	0.59	0.60
L	0.33	0.36	0.25	0.42	0.43	0.48	0.50	0.66	0.47	0.60
M	0.34	0.34	0.32	0.32	0.34	0.36	0.36	0.23	0.25	0.38
N	0.29	0.29	0.28	0.34	0.36	0.63	0.73	0.53	0.67	0.42
O	0.24	0.27	0.26	0.27	0.29	0.48	0.75	0.56	0.57	0.64
P	0.39	0.34	0.35	0.33	0.37	0.36	0.50	0.23	0.50	0.61
Q	0.28	0.27	0.28	0.27	0.24	0.53	0.69	0.31	0.65	0.39
R	0.28	0.30	0.27	0.35	0.37	0.62	0.56	0.64	0.57	0.51
S	0.32	0.35	0.22	0.41	0.42	0.55	0.71	0.69	0.58	0.65
T	0.24	0.29	0.29	0.28	0.31	0.32	0.59	0.23	0.31	0.51

Note: $T_B = 22.5$ seconds, $E_S = 1.55$.

Appendix 5: Programming source code

Car Driving Simulator

```
// CarDlg.cpp : implementation file
```

```
//
```

```
#include "stdafx.h"
```

```
#include "Car.h"
```

```
#include "CarDlg.h"
```

```
#include <vector>
```

```
#include "include\dx_input.h"
```

```
using namespace std;
```

```
#ifdef _DEBUG
```

```
#define new DEBUG_NEW
```

```
#endif
```

```
struct Keys {
```

```
bool up;
```

```
bool down;
```

```
bool left;
```

```
bool right;
```

```
};
```

```
boolbType;
```

```
Keys keys;
```

```
D3DXVECTOR3 eye;
```

```
structsPointF{
```

```
sPointF(float _x, float _y)
```

```
{
    x = _X;
    y = _Y;
}

float x;

float y;

};

using namespace lib;

volatilebool flag;

vector<sPointF>pt;

// Your data is in this vector
vector<sPointF>ptVehicle;

VertexBuffer v;

DWORD dwColorPath = 0xff00ff00; // green

float velocity = 0;

float angle = 0;

float norm = 0.1f;

floatscale_diff = 250.0f;

UINT __cdeclBasicThread( LPVOID pParam )
{
    // CHANGED

    ptVehicle.clear();

    CCarDlg *dlg = (CCarDlg*) pParam;

    HWND hwnd = dlg->m_surface.GetSafeHwnd();
```

```
CRectrect;

dlg->m_surface.GetWindowRect(&rect);

Surface3D *surf = new Surface3D();

int WIDTH = rect.Width();

int HEIGHT = rect.Height();

if(!surf->Create(WIDTH, HEIGHT, 1, hwnd,
               e3DFormat_A8R8G8B8, e3DAccel_Hardware, DEGREE2RADIAN(45.0f)))
{
    AfxMessageBox("Failed creating hardware renderer.\nYou need a graphics
card!\nTrying a software renderer instead.");
    if(!surf->Create(WIDTH, HEIGHT, 1, hwnd,
                   e3DFormat_A8R8G8B8, e3DAccel_Software, DEGREE2RADIAN(45.0f)))
    {
        AfxMessageBox("Even software renderer failed.\nCall Hafis");
        delete surf;
        return -1;
    }
}

// y is always fixed
// z is start of grid at -500.0f
// x is centered
//eye = D3DXVECTOR3 (0.0f, 200.0f, -500.0f);
D3DXVECTOR3 lookat(0, 30, 0);
```

```
// Load Meshes/Models
surf->LoadXFile("sedan.x", 0);
surf->SetClearColor(0,0,0,255);
surf->EnableLight(false);
surf->SetAmbientColor(255,255,255,255);

surf->SetViewMode(e3DViewMode_PanTilt);

surf->SetYaw(DEGREE2RADIAN(lookat.x));
surf->SetPitch(DEGREE2RADIAN(lookat.y));
surf->SetRoll(lookat.z);

surf->SetFoV(DEGREE2RADIAN(45));
surf->SetRenderMode(e3DRender_Solid);
surf->GetDevice()->SetFVF(D3DFVF_XYZ | D3DFVF_DIFFUSE);

DWORD dwGridColor = 0xFF6F6F6F; // Light gray (3D Grid color)

v.Clear();
v.SetPrimitiveType(D3DPT_LINESTRIP);

for(unsigned int i = 0; i < pt.size(); i++)
{
    // map size is 500x500, so normalize to 250
    v.Add(VERTEXDIFFUSED( (pt[i].y-scale_diff)/norm, 5, (pt[i].x)/norm, dwColorPath));
}
```

```
if (pt.size() !=0)
{
    // CHANGED
    eye = D3DXVECTOR3 ((pt[0].y-scale_diff)/norm, 200.0f, (pt[0].x)/norm - 200.0f);
    //TRACE("Pos %.3f, %.3f", (pt[0].y-scale_diff)/norm, (pt[0].x)/norm);
    //TRACE("Pos %.3f, %.3f, %.3f", eye.x, eye.y, eye.z);

}
else { eye = D3DXVECTOR3 (0.0f, 200.0f, -500.0f); }
```

```
v.CreateVertexBuffer(surf);
//Add crosshair into the car structure
VertexBuffer crosshair;
crosshair.SetPrimitiveType(D3DPT_LINELIST);

DWORD redColor = 0xFFFF0000;
//crosshair.Add( VERTEXDIFFUSED( -25, 0, 0, redColor));
crosshair.Add( VERTEXDIFFUSED( -20, 0, 30, redColor));
//crosshair.Add( VERTEXDIFFUSED( 25, 50, 0, redColor));
crosshair.Add( VERTEXDIFFUSED( 20, 40, 30, redColor));

//crosshair.Add( VERTEXDIFFUSED( 25, 0, 0, redColor));
crosshair.Add( VERTEXDIFFUSED( 20, 0, 30, redColor));
//crosshair.Add( VERTEXDIFFUSED( -25, 50, 0, redColor));
crosshair.Add( VERTEXDIFFUSED( -20, 40, 30, redColor));
crosshair.CreateVertexBuffer(surf);
```

```
floatcurr_ang = 0;
floatcurr_posb= 0; // not negative

// Fixed properties, things that dont change a lot
surf->SetRenderMode(e3DRender_Wireframe);
surf->SetScaling(D3DXVECTOR3(1.0f, 1.0f, 1.0f));

DWORD dwGridColorPath = 0xFFFF0000; // Light gray (3D Grid color)
VertexBuffer path;
path.Clear();
path.SetPrimitiveType(D3DPT_LINESTRIP);

bool run = false;

DWORD start;
DWORD end;

while(flag)
{
    // update position and angle
    // if car is not moving, u can't turn!
    if(!(velocity < 0.1f) )
    {
        curr_ang += angle;
    }

    if((velocity > 0.1f) && !run)
    {
        start = GetTickCount();
    }
}
```

```
        run = true;

        CStringstrTime;
        strTime.Format("Timing...");
        dlg->m_time.SetWindowText(strTime);
    }

    if((velocity < 0.1f) && run)
    {
        end = GetTickCount();
        run = false;

        DWORD fTimeDiff = end - start;

        CStringstrTime;
        strTime.Format("%.3f sec", (float) fTimeDiff/1000.0f);
        dlg->m_time.SetWindowText(strTime);
    }

    if((velocity > 0.1f) && run)
    {
        end = GetTickCount();

        DWORD fTimeDiff = end - start;

        CStringstrTime;
        strTime.Format("%.3f sec", (float) fTimeDiff/1000.0f);
        dlg->m_time.SetWindowText(strTime);
    }
}
```

```
surf->BeginScene();

// Just move the camera - it is easier
// eye - is where the camera is, and it moves!

// 1.   Add displacement to the camera position
//       Y-position is camera height and is fixed
//       velocity is the actual vector direction + strength
//       decompose it into x-z magnitudes

float da = curr_ang + 90.0f; // default angle is 90
float dx = velocity*cos(DEGREE2RADIAN(da));
float dz = velocity*sin(DEGREE2RADIAN(da));

D3DXVECTOR3 vCamPos = eye + D3DXVECTOR3(-dx, 0, dz);
surf->SetCameraEyePoint(vCamPos);

// 2.   Camera rotation, its just the camera yaw.
//       adjust it by adding the angle to the current angle.
//       current angle is - lootat.x

lookat.x = curr_ang;
surf->SetYaw(DEGREE2RADIAN(lookat.x));

// Grid and world space
// World is always fixed
// So is our fixed path
surf->SetRotationCenter(D3DXVECTOR3(0,0,0));
surf->SetRotationY(DEGREE2RADIAN(0));
surf->SetTranslation(D3DXVECTOR3(0,0,0));
```



```

surf->SetupMatrices();

Draw_Grid(surf->GetDevice(), 50, -5000, 5000, -5000, 5000, dwGridColor);

surf->DrawVertexBuffer(&v);

//TRACE("\n %d, %d", ptVehicle.size(), path.GetSize());

// Draw current path
if((ptVehicle.size() > 1) && (ptVehicle.size() != path.GetSize() )
{
    for(unsigned int k = path.GetSize(); k < ptVehicle.size(); k++)
    {
        // map size is 500x500, so normalize to 250
        path.Add(VERTEXDIFFUSED( ptVehicle[k].y, 5, ptVehicle[k].x,
dwGridColorPath));
    }

    path.CreateVertexBuffer(surf);

}

surf->DrawVertexBuffer(&path);

// Now lets draw our model car
// Car position is ahead of the camera by

const float dist = 200.0f; // distance of model to camera
float da_c = curr_ang + 90.0f; // default angle is 90
float dx_c = dist*cos(DEGREE2RADIAN(da_c));
float dz_c = dist*sin(DEGREE2RADIAN(da_c));

```

```

D3DXVECTOR3 vCarPos = vCamPos + D3DXVECTOR3(-dx_c, -200.0f, dz_c);

surf->SetTranslation(vCarPos);

// Car angle is -90.0f (model correction) + current view angle + simulated
turning angle
surf->SetRotationY(DEGREE2RADIAN(-90.0f) + DEGREE2RADIAN(curr_ang) +
DEGREE2RADIAN(angle*10.0f));
surf->SetupMatrices();
surf->RenderMesh(0);

surf->SetRotationY(DEGREE2RADIAN(curr_ang) +
DEGREE2RADIAN(angle*10.0f));
surf->SetupMatrices();
surf->DrawVertexBuffer(&crosshair);

// update camera position
eye = vCamPos;

// Get current position
if(ptVehicle.size() == 0)
{
    //ptVehicle.push_back(sPointF(eye.z, eye.x));
    // CHANGED
    ptVehicle.push_back(sPointF(vCarPos.z, vCarPos.x));

    //TRACE("\n %d, Added a point, %.3f, %.3f", ptVehicle.size(),
vCarPos.z, vCarPos.z);

    //if(pt.size() > 0)
    //TRACE("\n Actual posPos %.3f, %.3f", (pt[0].y-scale_diff)/norm,
(pt[0].x)/norm);
}

```

```

    }
    else
    {
        D3DXVECTOR3 vCurr = D3DXVECTOR3(ptVehicle[ptVehicle.size()-
1].y, 0, ptVehicle[ptVehicle.size()-1].x);

        //D3DXVECTOR3 vDiff = vCurr - eye;

        // CHANGED
        D3DXVECTOR3 vDiff = vCurr - vCarPos;

        //TRACE("\r %.3f, %.3f", vDiff.x, vDiff.z);

        if( (fabs(vDiff.x) > 1.0f) || (fabs(vDiff.z) > 1.0f) )
        {
            // CHANGED
            //ptVehicle.push_back(sPointF(eye.z, eye.x));
            ptVehicle.push_back(sPointF(vCarPos.z, vCarPos.x));

            //TRACE("\n %d, Added a point, %.3f, %.3f", ptVehicle.size(),
eye.x, eye.z);
        }
    }

    surf->EndScene();
    surf->Present();

    Sleep(1000/30); // 30 frames-per-second rendering (limited)
}

delete surf;

```

```
return 0;
}

// CAboutDlg dialog used for App About

classCAboutDlg : public CDialog
{
public:
CAboutDlg();

// Dialog Data
enum { IDD = IDD_ABOUTBOX };

protected:
virtual void DoDataExchange(CDataExchange* pDX); // DDX/DDV support

// Implementation
protected:
DECLARE_MESSAGE_MAP()
};

CAboutDlg::CAboutDlg() : CDialog(CAboutDlg::IDD)
{
}

voidCAboutDlg::DoDataExchange(CDataExchange* pDX)
{
CDialog::DoDataExchange(pDX);
}
```

```
BEGIN_MESSAGE_MAP(CAboutDlg, CDialog)

END_MESSAGE_MAP()

// CCarDlg dialog

CCarDlg::CCarDlg(CWnd* pParent /*=NULL*/)
: CDialog(CCarDlg::IDD, pParent)
{
    m_hIcon = AfxGetApp()->LoadIcon(IDR_MAINFRAME);
}

void CCarDlg::DoDataExchange(CDataExchange* pDX)
{
    CDialog::DoDataExchange(pDX);
    DDX_Control(pDX, IDC_SURFACE, m_surface);
    DDX_Control(pDX, IDC_TIME, m_time);
    DDX_Control(pDX, IDC_CMBUSERINPUT, m_inputDevice);
}

BEGIN_MESSAGE_MAP(CCarDlg, CDialog)
    ON_WM_SYSCOMMAND()
    ON_WM_PAINT()
    ON_WM_QUERYDRAGICON()
    //}}AFX_MSG_MAP
    ON_COMMAND(ID_FILE_EXIT, &CCarDlg::OnFileExit)
    ON_COMMAND(ID_FILE_OPENMAP, &CCarDlg::OnFileOpenmap)
    ON_WM_TIMER()
    ON_COMMAND(ID_FILE_SAVEPATH, &CCarDlg::OnFileSavepath)
    ON_BN_CLICKED(IDC_BUTTON1, &CCarDlg::OnBnClickedOpenMap)
    ON_BN_CLICKED(IDC_BUTTON2, &CCarDlg::OnBnClickedSaveMap)
```

```
ON_BN_CLICKED(IDC_BUTTON3, &CCarDlg::OnBnClickedExit)
ON_CBN_SELCHANGE(IDC_CMBUSERINPUT, &CCarDlg::OnCbnSelchangeCmbuserinput)
END_MESSAGE_MAP()
```

```
// CCarDlg message handlers
```

```
BOOL CCarDlg::OnInitDialog()
```

```
{
```

```
    CDialog::OnInitDialog();
```

```
    // Select default input
```

```
    InputDevice = INPUTDEVICE_KEYBOARD;
```

```
    m_inputDevice.SetCurSel(INPUTDEVICE_KEYBOARD);
```

```
    // Init default settings
```

```
    InitDefault();
```

```
    dxinput::PopulateEffects();
```

```
    // Add "About..." menu item to system menu.
```

```
    // IDM_ABOUTBOX must be in the system command range.
```

```
    ASSERT((IDM_ABOUTBOX & 0xFFF0) == IDM_ABOUTBOX);
```

```
    ASSERT(IDM_ABOUTBOX < 0xF000);
```

```
    CMenu* pSysMenu = GetSystemMenu(FALSE);
```

```
    if (pSysMenu != NULL)
```

```
    {
```

```
        BOOL bNameValid;
```

```
        CStringstrAboutMenu;
```

```
        bNameValid = strAboutMenu.LoadString(IDS_ABOUTBOX);
        ASSERT(bNameValid);
        if (!strAboutMenu.IsEmpty())
        {
            pSysMenu->AppendMenu(MF_SEPARATOR);
            pSysMenu->AppendMenu(MF_STRING, IDM_ABOUTBOX, strAboutMenu);
        }
    }
```

```
// Set the icon for this dialog. The framework does this automatically
```

```
// when the application's main window is not a dialog
```

```
SetIcon(m_hIcon, TRUE);                // Set big icon
```

```
SetIcon(m_hIcon, FALSE);             // Set small icon
```

```
// Default, no keys pressed
```

```
memset(&keys, 0, sizeof(Keys));
```

```
//SetTimer(0, 1000/30, NULL);
```

```
SetTimer(0, 1000/250, NULL);
```

```
CRectrect;
```

```
m_surface.GetWindowRect(&rect);
```

```
TRACE("\nWindowRect is %d, %d", rect.Width(), rect.Height());
```

```
flag = true;
```

```
AfxBeginThread(BasicThread, this);
```

```
// DInput Initialization
```

```
dxinput::hDlG = this->GetSafeHwnd();
```

```
dxinput::InitDirectInput(dxinput::hDlG);
```

```
CheckUSBDeviceStatus();

return TRUE; // return TRUE unless you set the focus to a control
}

void CCarDlg::OnSysCommand(UINT nID, LPARAM lParam)
{
    if ((nID & 0xFFF0) == IDM_ABOUTBOX)
    {
        CAboutDlg dlgAbout;
        dlgAbout.DoModal();
    }
    else
    {
        CDialog::OnSysCommand(nID, lParam);
    }
}

// If you add a minimize button to your dialog, you will need the code below
// to draw the icon. For MFC applications using the document/view model,
// this is automatically done for you by the framework.

void CCarDlg::OnPaint()
{
    if (IsIconic())
    {
        CPaintDC dc(this); // device context for painting
```



```
SendMessage(WM_ICONERASEBKGND,  
reinterpret_cast<WPARAM>(dc.GetSafeHdc()), 0);
```

```
// Center icon in client rectangle  
int cxIcon = GetSystemMetrics(SM_CXICON);  
int cyIcon = GetSystemMetrics(SM_CYICON);  
CRect rect;  
GetClientRect(&rect);  
int x = (rect.Width() - cxIcon + 1) / 2;  
int y = (rect.Height() - cyIcon + 1) / 2;
```

```
// Draw the icon  
dc.DrawIcon(x, y, m_hIcon);
```

```
}
```

```
else
```

```
{
```

```
    CDialog::OnPaint();
```

```
}
```

```
}
```

```
// The system calls this function to obtain the cursor to display while the user drags
```

```
// the minimized window.
```

```
HCURSOR CCarDlg::OnQueryDragIcon()
```

```
{
```

```
return static_cast<HCURSOR>(m_hIcon);
```

```
}
```

```
void CCarDlg::OnFileExit()
```

```
{
```

```
OnOK();  
}
```

```
/*  
PreTranslate key messages, so that all key presses  
are sent to the dialog window, and then we can process  
them.
```

You can remove this part, if you decide to use DXInput
orXInput.

```
*/  
BOOL CCarDlg::PreTranslateMessage(MSG* pMsg)  
{  
    // Process only if is keyboard  
    if(InputDevice == INPUTDEVICE_KEYBOARD)  
    {  
        if(pMsg->message==WM_KEYDOWN)  
        {  
            if(pMsg->wParam==VK_UP) keys.up = true;  
            if(pMsg->wParam==VK_DOWN) keys.down = true;  
            if(pMsg->wParam==VK_LEFT) keys.left = true;  
            if(pMsg->wParam==VK_RIGHT) keys.right = true;  
        }  
        else if (pMsg->message == WM_KEYUP)  
        {  
            if(pMsg->wParam==VK_UP) keys.up = false;  
            if(pMsg->wParam==VK_DOWN) keys.down = false;  
            if(pMsg->wParam==VK_LEFT) keys.left = false;  
            if(pMsg->wParam==VK_RIGHT) keys.right = false;  
        }  
    }  
}
```

```
}

returnCDialog::PreTranslateMessage(pMsg);
}

/*
This is to open a saved MAP file.
MAP files must first be created by MapMaker.
*/
voidCCardDlg::OnFileOpenmap()
{
flag = false;
Sleep(500);

CFileDialogdlg(true, ".txt", "track.txt");

if(dlg.DoModal() == IDOK)
{
    CStdioFile file;
    if(file.Open(dlg.GetPathName(),CFile::modeRead))
    {
        pt.clear();

        CStringstr;

        while(file.ReadString(str))
        {

            intreadpt[2];
            int index = 0;
```

```
        CString token;
        int p = 0;

        while((token = str.Tokenize(",", p)) != "")
        {
            readpt[index] = atoi(token);
            index++;
        }

        sPointFptTemp( (float) readpt[0], (float) readpt[1]);
        pt.push_back(ptTemp);
    }

    file.Close();

    this->Invalidate(false);
}

}

flag = true;
AfxBeginThread(BasicThread, this);
}

void CCarDlg::OnTimer(UINT_PTR nIDEvent)
{
    if(InputDevice == INPUTDEVICE_KEYBOARD)
    {
        // Keyboard handler, just like before
        const float v_inc = 0.1f; // velocity increment
        const float a_inc = 0.1f; // angle increment
```

```

const float max_a = 2.0f;

const float min_a = -2.0f;

const float max_v = 10.0f;

if(keys.down)  velocity-=v_inc*2;

if(keys.up)    velocity+=v_inc;

if(keys.left)  angle-=a_inc;

if(keys.right) angle+=a_inc;

if(!keys.right&& !keys.left) angle = 0;

if(!keys.up&& !keys.down) velocity-=v_inc;

velocity = min(max(velocity, 0),max_v);

angle = min(max(angle,min_a),max_a);

}

else if (InputDevice == INPUTDEVICE_STEERING)

{

    // Steering handler

    dxinput::UpdateInputState(dxinput::hDlg );

    TRACE("\nSteering is %d", dxinput::momo.x);

    TRACE("\nPedal is %d", dxinput::momo.z);

    for(int i=0; i<10; i++)

        if(dxinput::momo.button[i])

            TRACE("\n Button %d is pressed",i);

    const float v_inc = 0.1f; // velocity increment

    const float a_inc = 0.1f; // angle increment

    const float max_a = 2.0f;

    const float min_a = -2.0f;

    const float max_v = 10.0f;

    angle = (float) dxinput::momo.x / 1000.0f * max_a; //steering movement

    if(dxinput::momo.zR)  velocity-=v_inc*2;

```

```
        velocity = -(float) dxinput::momo.z / 1000.0f * max_v;
        velocity = min(max(velocity, 0),max_v);
    }

    CDialog::OnTimer(nIDEvent);
}

void CCarDlg::OnDestroy()
{
    CDialog::OnDestroy();

    // Cleanup
    KillTimer(0);
    dxinput::FreeDirectInput();
}

void CCarDlg::OnActivate(UINT nState, CWnd* pWndOther, BOOL bMinimized)
{
    CDialog::OnActivate(nState, pWndOther, bMinimized);

    if( WA_INACTIVE != dxinput::g_pFFDevice )
    {
        // Make sure the device is acquired, if we are gaining focus.
        dxinput::g_pFFDevice->Acquire();
    }
}

void CCarDlg::OnFileSavepath()
{
```

```
if(AfxMessageBox("Save path will stop the car simulator.\nAre you sure you want to
proceed?", MB_OKCANCEL)== IDOK)
{
    flag = false;
    Sleep(500);

    CFileDialogdlg(false, ".txt", "*.txt");

    if(dlg.DoModal() == IDOK)
    {
        CStdioFile file;
        if(file.Open(dlg.GetPathName(), CFile::modeCreate | CFile::modeWrite ))
        {
            for(unsigned int i = 0; i <ptVehicle.size(); i++)
            {
                CStringstrData;
                strData.Format("%d,%d\r\n", (int) (ptVehicle[i].x*norm),
(int) (ptVehicle[i].y*norm + scale_diff ));
                file.Write(strData, strData.GetLength());
            }

            file.Close();
        }
    }
    ptVehicle.clear();
    flag = true;
    AfxBeginThread(BasicThread, this);
}
}
```



```
voidCCarDlg::OnBnClickedOpenMap()
```

```
{
// TODO: Add your control notification handler code here

flag = false;

Sleep(500);

CFileDialog dlg(true, ".txt", "track.txt");

if(dlg.DoModal() == IDOK)
{
    CStdioFile file;
    if(file.Open(dlg.GetPathName(), CFile::modeRead))
    {
        pt.clear();

        CString str;

        while(file.ReadString(str))
        {

            int readpt[2];
            int index = 0;
            CString token;
            int p = 0;

            while((token = str.Tokenize(",", p)) != "")
            {
                readpt[index] = atoi(token);
                index++;
            }
        }
    }
}
```



```
        sPointFptTemp( (float) readpt[0], (float) readpt[1]);
        pt.push_back(ptTemp);
    }

    file.Close();

    this->Invalidate(false);
}

}

flag = true;
AfxBeginThread(BasicThread, this);
}

void CCarDlg::OnBnClickedSaveMap()
{
    // TODO: Add your control notification handler code here

    if(AfxMessageBox("Save path will stop the car simulator.\nAre you sure you want to
    proceed?", MB_OKCANCEL)== IDOK)
    {
        flag = false;
        Sleep(500);

        CFileDialogdlg(false, ".txt", "*.txt");

        if(dlg.DoModal() == IDOK)
        {
            CStdioFile file;
            if(file.Open(dlg.GetPathName(), CFile::modeCreate | CFile::modeWrite ))
            {
```

```
        for(unsigned int i = 0; i <ptVehicle.size(); i++)
        {
            CStringstrData;

            strData.Format("%d,%d\r\n", (int) (ptVehicle[i].x*norm),
(int) (ptVehicle[i].y*norm + scale_diff) );

            file.Write(strData, strData.GetLength());

        }

        file.Close();

    }

}

ptVehicle.clear();

flag = true;

AfxBeginThread(BasicThread, this);

}

}
```

```
voidCCarDlg::OnBnClickedExit()
{
// TODO: Add your control notification handler code here
OnOK();
}
```

```
voidCCarDlg::OnCbnSelchangeCmbuserinput()
{
// Change Selection of user input (26 Feb 09)
// Get's current mode
// Selection = 0, Keyboard
// Selection = 1, Steering
InputDevice = m_inputDevice.GetCurSel();
```

```
// Change focus to dialog (to avoid keyboard input to combobox)
this->SetFocus();

// Check the availability of USB Steering
// If not available, change back to keyboard mode automatically
if(!CheckUSBDeviceStatus())
{
    InputDevice = INPUTDEVICE_KEYBOARD;
    m_inputDevice.SetCurSel(INPUTDEVICE_KEYBOARD);
}
}

bool CCarDlg::CheckUSBDeviceStatus()
{
    // Checks the USB device status
    if(!v1.bJoystick && InputDevice == INPUTDEVICE_STEERING)
    {
        AfxMessageBox("No compatible USB input devices found.\n Reverting to keyboard
input.");
        return false;
    }
    else return true;
}
```