

This item was submitted to Loughborough University as a PhD thesis by the author and is made available in the Institutional Repository (<https://dspace.lboro.ac.uk/>) under the following Creative Commons Licence conditions.

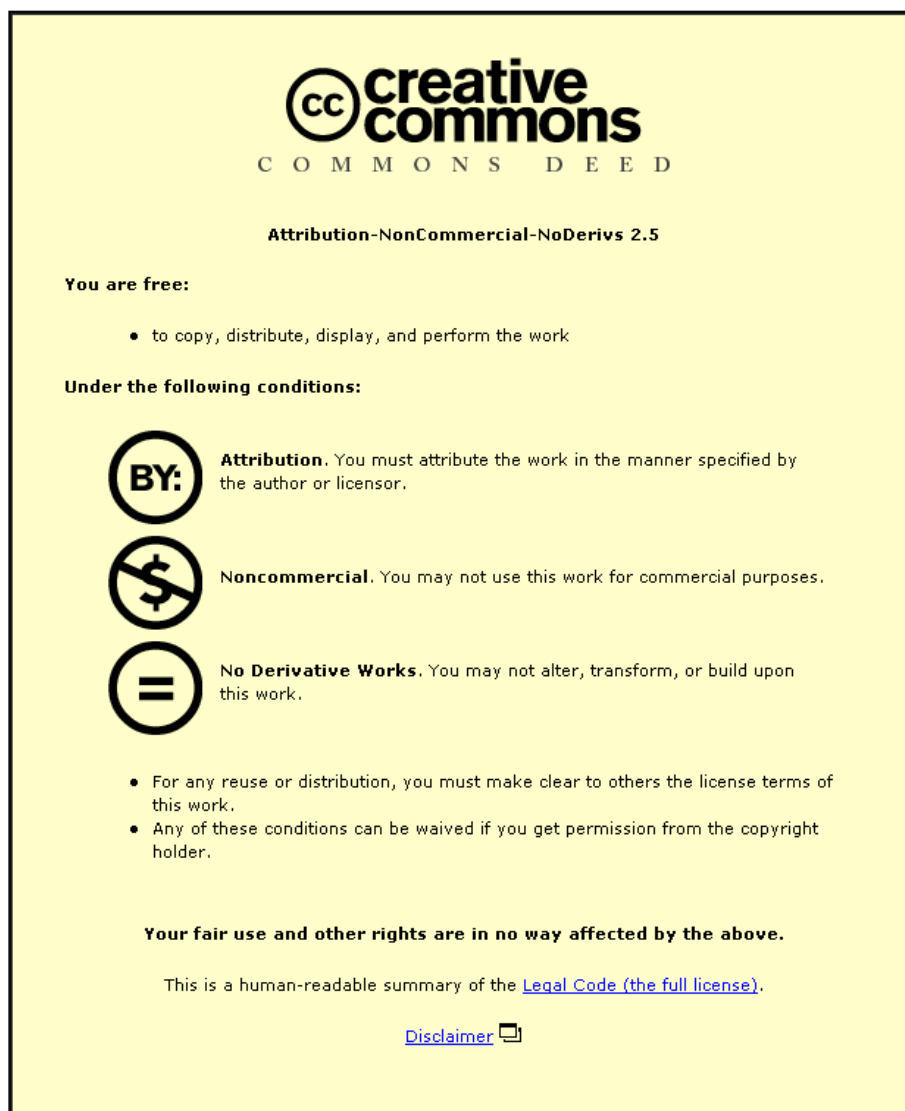

For the full text of this licence, please go to:
<http://creativecommons.org/licenses/by-nc-nd/2.5/>

The Development of Product Design Guidelines Based on a New Conceptual Framework

Keaboka Motona Sethebe

B. Eng (Mechanical Engineering)
University of Botswana
Gaborone, South East District
Botswana

M. Eng (Mechanical Engineering)
University of the Witwatersrand
Braamfontein, Johannesburg
South Africa

A Thesis submitted to the Loughborough University in partial
fulfilment of the requirement for the degree of

DOCTOR OF PHILOSOPHY

Department of Mechanical and Manufacturing Engineering
Loughborough University
Loughborough, Leicestershire

© Keaboka Motona Sethebe 2012

DEDICATION

To my family
for their constant support, patience, understanding and love
especially my children: Leah, Motona and Nkatlapo

DECLARATION

No portion of the work referred to in this thesis has been submitted in support of an application for any other degree or qualification of this or any other University or other institute of learning.

ACKNOWLEDGEMENTS

I am indebted to thank my supervisors Mr. Andrew John Taylor and Prof. Weeratunga Malalasekera for their constant supervision, assistance, constructive criticism and inspiration.

I wish to also express my sincere gratitude to the Rural Industries Promotions Company (Botswana) and the Department of Research, Science and Technology in Botswana for the financial and logistic support they provided to this research. I owe appreciation and gratefulness to the national administrative and management system that established the “Training of Scientists and Technologist” research sponsorship and nominated me to do this research.

I would also like to thank Director of Research in the Wolfson School of Mechanical and Manufacturing Engineering for accepting my application for the place at this department.

Gratitude must also be extended to the independent assessor, Dr. Peter Willmot for the helpful discussion emanating from annual examinations of this research.

I would like to convey my thankfulness to the Botswana Technology Centre, Progressive Sports, National Food Technology Research Centre, University of Botswana, Progressive Sports Ltd and the Department of Civil and Building Engineering, Loughborough University for the cooperation given to the interviews.

ABSTRACT

The work described provides the development, implementation and evaluation of engineering product design guidelines suitable for engineering product designers. The motivation arises from collaborative efforts that continue to be made by the Least Economically Developed Countries (LDC) and the Most Economically Developed Countries (MDC) towards the development of the engineering design field. It is argued here that product design guidelines which are derived from existing product design methods enhance the capability of engineering designers to shorten time to market, deal adequately with product design constraints and boost supply chains.

The sample for the proposed study is comprised of companies in Botswana (a least economically developed country) and the United Kingdom (a most economically developed country). The research has been conducted using a mixed qualitative research approach comprised of aspects from the framework method, cluster analysis and Kolb's model. The findings have identified five themes central to the product design process which are incorporated into the engineering product design guidelines. Case study work was conducted to validate the approach.

The following claims are made for contributions to knowledge:

1. A conceptual framework which is a graphical co-ordinate system of engineering and management techniques required by nine engineering product design methods. The conceptual framework is arranged according to two orthogonal axes that describe the structure of the product design process and incorporate the need – function – form structure, the divergent – convergent structure, the product design drivers, product realisation process and product development lifecycles.
2. The product design method notation which is a register of the expressions derived from the conceptual framework and is used to communicate and aid in the selection of a group of techniques being implemented, or intended for implementation by design teams; and
3. The configuration scheme which provides a clear link between components, sub-assemblies, products, projects, programmes and policies.

The critical point put forward by this work is that the conceptual framework is only comprehensible today because the engineering product design methods in the public domain have imparted knowledge about the 'functions' of physical products (described here as part of the need – function – form structure) at the expense of human 'needs' and the interactive 'forms' of human responses to physical products. The contributions of this research provide a holistic and coherent means of integrating design methodologies for the benefit of design teams in Botswana. The approach is, however, universal and may also be beneficial for design projects in the most economically developed countries.

Keywords: Product Design Guidelines, Conceptual Framework, Design Method Notation, Design Drivers, Development Lifecycles, Product Realisation, Need-Function-Form, Divergent-Convergent, Configuration Scheme

ABBREVIATIONS

AD	Activity Diagram
ANSI	American National Standard Institute
ASA	Advertising Standard Authority
ASME	American Society of Mechanical Engineers
ATech	Appropriate Technology
BAMB	Botswana Agricultural Marketing Board
BFD	Block Flow Diagram
BNRSTP	Botswana Research, Science and Technology Plan
BoTeC	Botswana Technology Centre
CA	Customer Requirements or Attributes
CAD	Computer Aided Draughting
CEPCI	Chemical Engineering Plant Cost Index
CS	Configuration Sketches
DFID	Department for International Development
DP	Design Parameters
DRST	Department of Science, Research and Technology
DSM	Design Structure Matrix
ECOWAS	Economic Community of West African States
FAP	Financial Assistance Policy
FDI	Foreign Direct Investment
FES	Friedrich Ebert Stiftung Foundation
FR	Functional Requirements
FSD	Function Structure Diagram
GDP	Gross Domestic Product
GNI	Gross National Income

HALI	Horizontal Attribute Level Implementation
ICRISAT	International Crops Research Institute for the Semi-Arid Tropics
IDRC	International Development Research Centre
IEEE	Institute of Electrical and Electronic Engineers
ILO	International Labour Organisation
IOCD	Input-Output Concept Diagram
ITech	Intermediate Technology
LDC	Least Economically Developed Country
LU	Loughborough University
MDC	Most Economically Developed Country
MIST	Ministry of Infrastructure, Science and Technology
NIAE	National Institute of Agricultural Engineers
NFTRC	National Food Technology Research Centre
NICD	National Innovation Capabilities Database
OEM	Original Equipment Manufacturer
PDP	Product Delivery Process
PDS	Product Design Specification
PFD	Process Flow Diagram
PLA	Participatory Learning and Action
PuCC	Pugh Controlled Convergence
PV	Process Variables
QFD	Quality Function Deployment
R4D	Research for Development
RIIC	Rural Industries Innovation Centre
RIPCO (B)	Rural Industries Promotions Company (Botswana)
RST	Research Science and Technology

RSTI	Research, Science, Technology and Innovation Institutions
S&TP-B	Science and Technology Policy of Botswana
SACU	Southern African Customs Union
SADC	Southern African Development Community
SMME	Small, Micro and Medium Enterprise
TAL	Technological Adoption Lifecycle
TD	Technical Drawings
TRIZ	Teoriya Resheniya Izobratatelskikh Zadatch
UNIDO	United Nations Industrial Development Organisation
UK	United Kingdom
USA	United States of America
VD/RLI	Vertical Design Rule Level Implementation

SYMBOLS

A	Capacity
C_t	Cost
eX	Exports
$f()$	Function of
F_l	Lang Factor
G	Government Spending
i	Imports
I	Gross Investment
n	Exponent
PC	Private Consumption
$\mu_{mid-year}$	The National Population Size at Middle of the Year

TABLE of CONTENTS

DEDICATION	i
DECLARATION	ii
ACKNOWLEDGEMENTS.....	iii
ABSTRACT.....	iv
ABBREVIATIONS	v
SYMBOLS.....	viii
TABLE of CONTENTS.....	ix
LIST OF FIGURES.....	xiii
LIST OF TABLES.....	xvii
LIST OF EQUATIONS AND EXPRESSIONS	xix
Chapter 1: Introduction.....	1
1.0 Foreword.....	1
1.1 Research Context	1
1.1.1 Market Opportunities	3
1.1.2 Economic Transformation.....	4
1.2 Justification for the Research.....	9
1.2.1 Novelty (Statement of the Problem).....	9
1.3 Research Questions	12
1.4 Research Programme.....	13
1.4.1 Chapter Group #1.....	13
1.4.2 Chapter Group #2.....	14
1.5 Delimitation	15
1.6 Thesis Discourse.....	17
Chapter 2: Research Methodology	18
2.1 Justification of the Research Design Paradigm and Methodology	19
2.2 Identify a Research Problem	19
2.3 Choose a Research Goal.....	21
2.4 Choose and Frame a Method.....	22
2.4.1 Framework Analytical Approach.....	23
2.4.2 Cluster Analysis	23
2.4.3 Kolb’s Model	24
2.5 Apply the Method to Data	25

2.6 Decide on how Results Inform and are Useful.....	29
2.7 Decide whether the Research Problem has been Solved	29
2.8 Possible Sources of Error and Mitigation Plan.....	29
2.9 Summary	30
Chapter 3: Literature Review	31
3.1 Product Design Methods	32
3.1.1 The Types of Product Design Methods	32
3.2 Design Mapping Models	50
3.2.1 Activity Diagram	51
3.2.2 Tree Diagrams	52
3.2.3 Input-Output Concept Diagram	52
3.2.4 Block Flow Diagram.....	52
3.2.5 Configuration Sketches	54
3.2.6 Technical Drawings	55
3.3 Research, Science, Technology and Innovation Institutions involved in Product Design for the Least Economically Developed Countries	55
3.3.1 Programme - focused Research for Development.....	57
3.3.2 Issue - focused Research for Development	57
3.4 Examples of Failed Products	57
3.5 Summary	58
Chapter 4: Analysis of Design Methodologies	59
4.1 Introduction	59
4.2 Overview of Data Collection Methods.....	61
4.3 Aspects of the Qualitative Research Methodology which were Used in this Study	63
4.3.1 Framework	63
4.3.2 Cluster Analysis	67
4.3.3 Kolb's Model	72
4.4 Findings of the Qualitative Survey of Botswana and United Kingdom Industry.....	77
4.4.1 Literature-Based Engineering Product Design Guidelines – The Templates	77
4.4.2 Industry-Based Engineering Product Design Guidelines.....	84
4.4.3 The Structure of Product Design Methods	87
4.5 Discussion of the Qualitative Survey Findings	94
4.6 Summary	98
Chapter 5: Product Design Guidelines (PDG).....	99
5.1 Introduction	99

5.2 The Underlying Theory of the PDG: A Historical Perspective	99
5.3 The Features of the PDG: Perspectives on the Organisation of the Designer’s Toolkit	103
5.3.1 The Conceptual Framework: Lifecycles, Product Design Drivers and Product Realisation	103
4.3.2 Product Design Method Notation	106
5.3.3 Configuration Scheme.....	108
5.4 Summary of the Principles of the Product Design Guidelines	108
5.5 Implementation of the Conceptual Framework and Product Design Guidelines.....	110
5.6 Overview of the Difference between the Product Design Guidelines proposed by this Research and the Product Design Method practised at RIPCO (B)	110
5.6.1 Step 1: An Assessment of the Product Design Activities to be performed by Team of Design Professional(s) for Effectiveness	110
5.6.2 Step 2: The Identification of any Effective National Policy, Programme, Project and Stakeholders	112
5.6.3 Step 3: The Selection of the Appropriate Product Design Method Template or Formulation of a unique Product Design Procedure	116
5.6.4 Step 4: Quantify the required Design Effort and Resources.....	119
5.6.5 Shortcomings of Existing RIPCO(B) Design Methods	119
Chapter 6: Application of the Product Design Guidelines in Botswana.....	121
6.1 Introduction	121
6.2 Summary of the Principles of the PDG.....	121
6.3 Implementing the Product Design Guidelines by Modifying the RIPCO (B) Design Method....	122
6.3.1 Determination of the Product Design Drivers	123
6.3.1.1 Technological Yield - Design Rules 1, 2, 3 and 4	124
6.3.1.2 Technological Productivity - Design Rules 5 - 7	158
6.3.2 Product Realisation	176
6.4 Critical Evaluation of the Product Design Guidelines	220
6.4.1 The Value of Structured Product Design Methods	221
6.4.2 The Visibility obtainable from the establishment of a Culture of Productivity in the implementation of Product Design Activities	222
6.5 Summary	222
Chapter 7: Conclusions, Recommendations and Suggestions for Future Work	223
7.1 Conclusions	223
7.2 Recommendations	225
7.3 Suggestions for Future Work	225
References	226
Bibliography	243

Websites	245
Appendix 1: Exploratory Data on Research, Science and Technology Institutions in Botswana.....	246
Appendix 1: Exploratory Data on Research, Science and Technology Institutions in Botswana (Cont...)	247
Appendix 2: Covering Letter to Introduce the Researcher to Prospective Interviewees	248
Appendix 3: Questionnaire used in Pilot Structured Interviews	249
Appendix 3: Questionnaire used in Pilot Structured Interviews (Cont...)	250
Appendix 3: Questionnaire used in Pilot Structured Interviews (Cont...)	251
Appendix 3: Questionnaire used in Pilot Structured Interviews(Cont...)	252
Appendix 4: Final Version Questionnaire	253
Appendix 4: Final Version Questionnaire (Cont...)	254
Appendix 4: Final Version Questionnaire (Cont...)	255
Appendix 5: The UK Interview Respondents for Pilot and Final Structured Interviews	256
Appendix 6: The Botswana Interview Respondents for the Final Structured Interviews and the Participants in Kano Model Activities	257
Appendix 7: The Application of the PDG to the Design of the Planter – A Short Presentation.....	259
Appendix 7: The Application of the PDG to the Design of the Planter – A Short Presentation (Cont ...)	260
Appendix 7: The Application of the PDG to the Design of the Planter – A Short Presentation (Cont ...)	261
Appendix 8: Job Description - Grain/Food Production and Processing Programmes	262
Appendix 9: Paper to be Presented at the 12 Biennial Conference of the Botswana Institute of Engineers.....	263
From Botswana Brand to the <i>Kgotla</i> Economy: Using Botswana’s Cultural Heritage to inspire Innovative Product Design Activities	263
Synopsis:	263
1. Introduction	263
2. Culture and Competitive Enterprising between Districts	264
3. The Product Design Guidelines (PDG).....	267
4. Evolving the Appropriate Technologies into Intermediate Technologies	269
5. Conclusions	274
References	274

LIST OF FIGURES

Figure 1: Location of Botswana in Africa relative to SACU, SADC and ECOWAS Member Countries where the Dehuller was Diffused	4
Figure 2: Technology Adoption Lifecycle (Source: Adapted from Moore, 1998)	6
Figure 3: Components of GDP and Investment Growth	10
Figure 4: Research, Science, Technology and Innovation Institutions in Botswana	11
Figure 5: Research Programme	16
Figure 6: Research Method	18
Figure 7: Research Design (Source: Romesburg, 1984)	19
Figure 8: The Research Goal – Crossing the Chasm (Source: Adapted from Moore, 1998)	22
Figure 9: Kolb’s Model	25
Figure 10: Citation Metrics from Harzing’s Publish or Perish	27
Figure 11: Forward Citation Map developed through Google Scholar Database	28
Figure 12: Chapter Overview	31
Figure 13: The Four Domains in Axiomatic Design	33
Figure 14: Mapping, Decomposition, Zig-Zagging in Axiomatic Design - Showing only the Functional Domain and the Physical Domain(Source: Adapted from Suh, 1990)	34
Figure 15: Stage-Gate System (Source: Adapted from Copper, 1990)	36
Figure 16: Total Design (Source: Pugh, 1991)	38
Figure 17: Total Design (the dark arrows show the elements of the product design specification and the white arrows show iterations).....	39
Figure 18: Engineering Design as a central activity between Cultural and Technical Streams (Source: Pahl and Beitz, 1996)	40
Figure 19: Systematic Engineering Design Approach (Source: Pahl and Beitz, 1996)	41
Figure 20: TRIZ (Source: Ideation International Manual, 1996 cited in Terniko 1997).....	42
Figure 21: Quality Function Deployment	45
Figure 22: House of Quality	45
Figure 23: Robust Design (Taguchi Method).....	47
Figure 24: Reverse Engineering and Re-Design showing a Hybrid Waterfall-Concurrent Lifecycle (Source: Adapted from Otto and Wood, 2001)	48
Figure 25: Needs Assessment Techniques of the R4D Method	50
Figure 26: Process Input-Output Concept Diagram	52
Figure 27: Block Diagram showing Binary Information and Bit Codes	53
Figure 28: How Successful Least Economically Developed Countries Started (Source: Criscuolo and Palmade, 2008)	56
Figure 29: Types of Approaches to Product Design (Source: Adapted from Laws et. al, 2003)	56
Figure 30: Highlight of the Industry Surveys and Case Examples	60
Figure 31: Familiarisation Stage	64
Figure 32: Development of the Product Design Process Thematic Index. Note that the bolded words are a-priori issues related to the research objectives (Source: based on Pugh, 1991)	65
Figure 33: Indexed Transcript	65
Figure 34: Case Analysis Chart showing the Definition and Types of Product Design at RIPCO(B) [adapted from ISO 9000: 2000 Quality System Documentation Manual for RIPCO(B)].....	66
Figure 35: Typography of Total Design (Source: Adapted from Pugh, 1991)	70

Figure 36: Classification Tree that shows the similarities between the designer’s toolkit of Total Design and Axiomatic Design (Ward Linkage Dendogram with z-score Transform Values).....	70
Figure 37: Kolb’s Model used at RIPCO (B)	73
Figure 38: Research Platforms	75
Figure 39: The 3 Platforms and 17 Priority Research Areas of the BNRST Plan (Source: Keatimilwe, 2005)	76
Figure 40: Thematic Index.....	79
Figure 41: Indexed Research Notes (Source: Suh, 1990)	80
Figure 42: Sample from Total Design Case Analysis Chart.....	82
Figure 43: Topology of the Axiomatic Design and Quality Function Deployment	84
Figure 44: Development of Company Industry Thematic Index	86
Figure 45: Design Method at RIPCO(B) and Progressive Sports Ltd	87
Figure 46: The Divergent - Convergent Structure of the Overall Product Design and the Need - Function - Structure Localised to the Concept Generation and Selection "Period" (Source: Adapted from Cross, 1994).....	90
Figure 47: The Workflow of Total Design (Source: Pugh, 1991)	91
Figure 48: Techniques comprising the Market/User Needs of Total Design Method	92
Figure 49: Needs Assessment Techniques of the R4D Method	94
Figure 50: Product Design Process without Product Design Drivers	97
Figure 51: Product Design Process with the Proposed Product Design Drivers	97
Figure 52: The Intersection of representing an Engineering or Management Technique	103
Figure 53: Product Development Lifecycles.....	103
Figure 54: Conceptual Framework emphasising the Vee, Spiral Unified Process Lifecycle (Note the Introduction of the Iteration, the Change in the Complexity of Accompanying Design Mapping Models and the Cost Estimation Documentation)	105
Figure 55: Conceptual Framework for a Methodology similar to Robust Design.....	107
Figure 56: Conceptual Framework for a Methodology similar to Robust Design with specified Iterations.....	107
Figure 57: Attribute and Design Rule Implementation.....	112
Figure 58: The G/FP&P - ITech Programme, Projects, Products and Stakeholders	114
Figure 59: The Eleven Products that constitute the G/FP&P-ITech Project	115
Figure 60: The Nine products that constitute the B&CM-ITech Project.....	116
Figure 61: Product Design Method practiced at RIPCO(B) [adapted from ISO 9000: 2000 Quality System Documentation Manual for RIPCO(B)]	118
Figure 62: Modified Product Design Method Template	123
Figure 63: Design Principle or Rule 1: Customer Domain Information Sources - The Spiral Model Life Cycle of the Arable Agricultural Policy and Development Planning Programmes in Botswana	126
Figure 64: Customer Domain – ISPAAD and YFF Programmes (Planter Only)	127
Figure 65: Product Design Strategy for the ISPAAD and YFF Programmes.....	129
Figure 66: Kano Model and Porter's Forces for the ISPAAD and YFF Programmes	134
Figure 67: Activity Diagram for the ISPAAD and YFF Programmes (focusing on the Grain Planting) .	136
Figure 68: Design Rule 2 - Functional Domain - Grain Planting Product	141
Figure 69: Block Flow Diagram (Pneumatic Conveyor) - G/FP&P-ITech Programme and Product Functional Domain (without the Farm Implements and Secondary Food Grain Processing)	142

Figure 70: Block Flow Diagram (Screw Conveyor) - G/FP&P-ITech Programme and Product Functional Domain (without the Farm Implements and Secondary Food Grain Processing)	143
Figure 71: Design Principle or Rule 3 – Strategic Workforce Planning for G/FP&P-ITech (ISPAAD) and CE&E-ITech (YFF) Programme	146
Figure 72: Design Principle or Rule 3 - Organisational Structure for G/FP&P-ITech (ISPAAD) Programme Team on a National Scale.....	146
Figure 73: Design Principle or Rule 3 - Organisational Structure for G/FP&P-ITech (ISPAAD) Project Team on a RSTI Scale	147
Figure 74: Design Principle or Rule 4: Crossing the Chasm – G/FP&P ITech ISPAAD (<i>Morama</i> Milling Plant) Case Application (the YFF not included for clarity)	149
Figure 75: Quality Ladder – ISPAAD and YFF Programmes.....	150
Figure 76: Design Principle or Rule 4: Institutional Distribution Cluster (Industrial Districts) for the G/FP&P-ITech (ISPAAD) and the CE&E-ITech (YFF) Programme Case Application	152
Figure 77: Components of GDP and Investment Growth	157
Figure 78: Two-Way Directional North-South Technology Transfer.....	158
Figure 79: Market Positioning - Grain/Food Production and Processing Programmes.....	160
Figure 80: YFF and ISPAAD Value Chain	161
Figure 81: Purchasing Postponement (Note the suppression of Inbound Logistics and ISPAAD Forecast Driven Information Flow)	162
Figure 82: Manufacturing Postponement (Note the suppression of Operations)	162
Figure 83: Logistics Postponement (Note the suppression of Outbound Logistics)	162
Figure 84: ISPAAD and YFF Demand Management - Product Variety Proliferation Tree	164
Figure 85: Relational Matrix of the House of Quality that Identify Key Technologies (Planter Only).....	165
Figure 86: Design Rule 6 - Relational Matrix of the House of Quality that Identify Key Departments	170
Figure 87: Sample PDS of the Industrial Case Applications Programme	173
Figure 88: Elements of the PDS (Source: Pugh, 1991)	174
Figure 89: House of Quality for the Planter Product which is part of the G/FP&P – ITech Programme (as an example of the Sub-System Design Specifications).....	175
Figure 90: The Total, Sub-System and Component Levels of a Product represented through Configuration Sketches	177
Figure 91: The Steps of Conceptual Design	177
Figure 92: Sequence or Cluster of Creativity Aiding Methods.....	178
Figure 93: Analogy and Attribute Listing based on Traditional Grain Storage Artifacts as recorded by Philately and the Internet	179
Figure 94: Working Principles (Working Principles from Published Media)	180
Figure 95: The addition of Sub-Assemblies or Modules to a Product Platform, to enable performance of different Overall Functions demonstrating the Quality Ladder (shown here up to Three Steps) .	183
Figure 96: Concept Selection Process	184
Figure 97: Block Diagram for Photovoltaic Streetlight	186
Figure 98: Block Diagram for Botswana Power Corporation Streetlight	187
Figure 99: Block Diagram for Hybrid Powered Streetlight.....	187
Figure 100: Block Diagram for Light Emitting Diode Streetlight	188
Figure 101: Pro/Con Matrix	191
Figure 102: Convergence Matrix.....	192

Figure 103: Weighted Sum Matrix	193
Figure 104: Quotation for Steel	197
Figure 105: Technical Drawing of the Barrel, Hopper and Frame of Bulk Storage Bin	198
Figure 106: Isometric View of the Maize Dryer Beta Prototype (Source: RIPCO (B) Product Design Office).....	204
Figure 107: Section View of the Maize Dryer Beta Prototype (Source: RIPCO (B) Product Design Office).....	205
Figure 108: Maize Tray Dryer Prototype (Source: Project Design Office)	209
Figure 109: Psychrometrics Chart (Source: ASAE D271.2 DEC94 (ASAE Standard 1998) Accessed on http://www.ecaa.ntu.edu.tw/weifang/ebook/psy-data1998.pdf)	214
Figure 110: Heating Elements Casing.....	215
Figure 111: The Modified Maize Dryer Proof-of-Concept Prototype	217
Figure 112: Location of Botswana relative to SACU, SADC and ECOWAS Member Countries where the Dehuller was diffused	265
Figure 113: Crossing the Chasm to address an ITech gap [17]	267
Figure 114: Categorisation of RSTI according to Research Platforms required by the S&TP-B and BNRSTP.....	268
Figure 115: Strategic Workforce Planning for RSTI based in LDC. The dots indicate the techniques utilised in case study work to develop products for the Integrated Support Programme for Arable Agricultural Development (ISPAAD) and Young Farmers Fund (YFF) Programme	269
Figure 116: The Spiral Model Life Cycle of the Arable Agricultural Policy and Development Planning Programmes in Botswana	270
Figure 117: The Analytical Kano Model and Porter's Five Forces used to prioritise products for the ISPAAD and YFF Programmes	271
Figure 118: An Arbitrary Institutional Distribution Cluster (or Industrial Districts) for the ISPAAD and the YFF Programme showing Dots reminiscent of the Botswana Brand and the <i>Kgotla</i> Pillars and the colours from the Botswana Brand	272
Figure 119: Sequence or Cluster of Creativity Aiding Methods.....	273
Figure 120: Analogy and attribute listing based on Traditional Grain Storage Artefacts as recorded by philately and the internet (Source: Stamps pictures adapted from http://images-01.delcampe-static.net/img_large/auction/000/118/923/204_001.jpg)	273

LIST OF TABLES

Table 1: Summarised Differences between Appropriate Technology and Intermediate Technology ...	2
Table 2: Categories of Basic Needs of the Least Economically Developed Countries (Source: Adapted from Whitby, 1985).....	3
Table 3: Innovative Re-Design Strategies	7
Table 4: Growth and Economic Transformation of Cereal Mills in Botswana (Adapted from Rohrbach et. al., 2000)	7
Table 5: Thesis Discourse	17
Table 6: Types of Learners and their Characteristics with respect to Freewriting (Source: Sharp et. al., 1997)	25
Table 7: Generalised Engineering Parameters for Describing Product Metrics	43
Table 8: Engineering Design Principles	43
Table 9: Needs Assessment Techniques of the Research-for-Development Method (Source: Adapted from Schmidt 1987 and Laws et. al, 2003).....	49
Table 10: Innovative Movements	54
Table 11: Rules or Principles used in the Designer’s Toolkit	68
Table 12: Total Design Techniques	68
Table 13: Total Design Techniques Data Matrix (the Vee Lifecycle can be noted as depicted by the digit “1” in the Data Matrix.).....	69
Table 14: Thematic Analysis Chart of Identifying the Form and Nature of Existing Engineering Product Design Methods.....	81
Table 15: Thematic Analysis Chart to Emphasis the Influence of Partial Design.....	82
Table 16: Market/User Needs Techniques of the Total Design Method	91
Table 17: Needs Assessment Techniques of the Research-for-Development Method (Source: Adapted from Schmidt 1987 and Laws et. al, 2003).....	93
Table 18: Classification of Product Failures by Severity (Source: Lewis, 2000)	100
Table 19: Technological Yield - Design Principles or Rules 1 – 4.....	124
Table 20: Patent Search on ISPAAD and YFF Programmes (focusing only on the planter and excluding the Illustration of Drawings)	131
Table 21: Kano Evaluation Table for ISPAAD and YFF Programmes	133
Table 22: Design Principle or Rule 2: Materials and Energy Transformation Rates for the Food Grain Planting Product (focusing on some of the Basic Functions and Constraints only).....	137
Table 23: Basic Functions of Grain Planting and Food Grain Combine (i.e. combined Harvesting and Threshing)	140
Table 24: Economic and Productivity Advantages of Institutional Distribution Cluster.....	151
Table 25: Template for Current Technical Performance for the G/FP&P – ITech	155
Table 26: Template for Technological Map displaying Technological Limits for the G/FP&P – ITech	155
Table 27: Template for Technical Potential for the G/FP&P – ITech.....	156
Table 28: Technological Productivity - Design Principles or Rules 5 – 7.....	159
Table 29: Physical Quantities and Basic Physical Dimensions in the Metric System of Units	166
Table 30: Dimensions, Metrics Variable and Descriptions of Engineering Characteristics for the Grain Planting Product.....	166
Table 31: Recurring Variables for the Grain Planting Product.....	167

Table 32: Dimensions, Metrics Variable and Descriptions of Physical Quantities for the product variety proliferation tree	168
Table 33: Recurring Variables for the Product Platform.....	168
Table 34: Design Rule 6 - Sample of the Input and Output Analysis	171
Table 35: Morphological Analysis Chart for Grain Storage Product considered as the Product Platform (the Bold Boxes represent the Selected Sub-Assemblies)	182
Table 36: Design Rule 2 - The Basic Functions of the Food Grain Harvester, Food Grain Thresher, Food Grain Dryer, Food Grain Primary and Secondary Processor	182
Table 37: Annual Maintenance Costs	192
Table 38: Numerical Analysis	193
Table 39: Angle of Repose of Grain.....	195
Table 40: Bulk Density of Grain.....	196
Table 41: Maximum Mass of Grain that can be Stored	196
Table 42: Circumferential and Longitudinal Stress of the Grain on the Bulk Storage Bin	196
Table 43: Steel Section for supporting the Bulk Storage Bin	197
Table 44: Bill of Material for the Bin and Barrel of the Bulk Storage Bin (Source: Adapted from the RIPCO (B) Quality Office, 2008).....	200
Table 45: Production Process Plan to manufacture the Diffuser Appendage (Source: Adapted from the RIPCO (B) Quality Office, 2008)	200
Table 46: FMEA Chart template for the Barrel and Bin of the Bulk Storage Bin	201
Table 47: Master Production Schedule Template.....	201
Table 48: Inventory Record Template for the Barrel and Hopper	202
Table 49: Output Rate of the Maize Dryer.....	207
Table 50: The Model Variables and their Boundaries.....	207
Table 51: Experimental Set-Up	208
Table 52: Analysis of Variance	208
Table 53: Weight of the Maize Kernels before and after Soaking	217
Table 54: Summarised Differences between Appropriate Technology and Intermediate Technology	263
Table 55: Categories of Basic Needs of the Least Economically Developed Countries (Source: Adapted from Whitby, 1985).....	264
Table 56: Examples of Product Failures by Severity [26]	268

LIST OF EQUATIONS AND EXPRESSIONS

Equation 1: Gross National Income per capita	20
Equation 2: Gross Domestic Product	20
Equation 3: Gain for the Feedback Loop of Design.....	34
Equation 4: Order of Magnitude Cost Estimate.....	53
Equation 5: Lang Factor Method	55
Expression 6: Design Notation of the Product Design Method similar to Robust Design	106
Expression 7: Design Notation showing the Number of Iterations	107
Expression 8: General Root of the Configuration Scheme.....	108
Expression 9: Root to Name Product Design Methods.....	117
Expression 10: Root of the Case Application Product Design Method.....	117
Expression 11: Design Notation of the RIPC0 (B) Product Design Method.....	117
Expression 12: Sorghum Planting Case Application Product Name.....	117
Expression 13: Maize Dryer Case Application Product Name	117
Expression 14: Sorghum Milling Plant Case Application Product Name	117
Expression 15: <i>Morama</i> Milling Plant Case Application Product Name	118
Expression 16: Technological Yield	118
Expression 17: Technological Productivity.....	118
Expression 18: Product Realisation.....	119
Expression 19: Modified Technological Yield.....	123
Expression 20: Modified Technological Productivity.....	123
Expression 21: Root of the ISPAAD Case Application Product Design Method.....	125
Expression 22: Root of the YFF Case Application Product Design Method	125
Equation 23: Engineering Formulae for Gran Planting Product	167
Equation 24: π Equations.....	167
Equation 25: Engineering Formulae for the Product Platform	169
Equation 26: Energy Balance and Mass Balance Equations.....	170
Equation 27: Daily Power Consumption	188
Equation 28: Daily Electrical Current Consumption.....	189
Equation 29: Stored Electrical Energy.....	189
Equation 30: Discharge-Updated Stored Electrical Energy.....	189
Equation 31: Temperature-Updated Stored Electrical Energy	189
Equation 32: Number of Batteries	189
Equation 33: Updated Daily Electrical Current Consumption.....	190
Equation 34: Average Daily Charging Electrical Current.....	190
Equation 35: Electrical Current Consumption from a 60 W Solar Module.....	190
Equation 36: Required Solar Module.....	190
Equation 37: Pro/Con Matrix Evaluation Scale.....	191
Equation 38: Convergence Matrix Evaluation Scale	191
Equation 39: Maximum Effect	193
Equation 40: Normalized Maximum Effect of Selling Cost	193
Equation 41: Moisture Content	206
Equation 42: Mathematical Model of the Maize Dryer	208
Equation 43: Humidity ratio of Drying Air.....	211

Equation 44: Sensible Heat	211
Equation 45: Specific Heat of Capacity for Drying Air.....	211
Equation 46: Specific Enthalpy of Drying Air	211
Equation 47: Specific Enthalpy of Water Vapour i.e. Latent Heat of Water Vapour	212
Equation 48: Specific Heat of Capacity and Evaporation Heat for Water Vapour.....	212
Equation 49: Specific Enthalpy of Drying Air	212
Equation 50: Moisture Content (Wet Basis)	212
Equation 51: Moisture Content (Dry Basis)	213
Equation 52: Moisture Content (Wet Basis) of Maize Kernels	218
Equation 53: Moisture Content (Dry Basis) of Maize Kernels.....	218
Equation 54: Gross Domestic Product	266
Expression 55: Syntax of the Maize Dryer (Excluding the Policies, Sub-Assemblies and Components)	271

Chapter 1: Introduction

1.0 Foreword

Since independence from the United Kingdom in 1966, Botswana has had one of the relatively high average economic growth rates in the world – averaging about 7.5% per year between 1970 and 2000 (Togo, 2008). The Botswana Government has had budget surpluses with good foreign exchange reserves. Its impressive economic record is built on diamond mining; according to [Transparency International](#) (2009) – it is rated the least corrupt country in Africa.

After 30 years of independence (in 1996), Botswana's *Vision 2016* was developed and it favoured an economy diversified into research, science and technology (Vision 2016 Taskforce, 1997). Consequently, the Science and Technology Policy for Botswana was passed by parliament in 1998 which, among other issues, requires the development of products from within Botswana; an important concern is the need for a customisable product design methodology to deal with the standardising of technical documentation, identification of innovative techniques, reduction of massive engineering risk, simplification of technology transfer to local manufacturers as well as to aid in the identification (and generation) of deliverables for funding.

This situation for industrial development and economic transformation through innovative entrepreneurial use of research, science and technology may be common to other least economically developed countries which would also benefit from this research which looks in the implementation efforts of Botswana. This research is specifically concerned with the industrial practice of product design activities to the least developed economies – for both local consumption and export quality.

1.1 Research Context

Botswana has relied, and still largely depends, on imported products for its needs and for many years design had been largely concerned with modification of imported products in an attempt to satisfy local requirements. This approach is not successful and an indigenous design capability is being encouraged. From direct involvement in commercial design projects over a period commencing from 1999, the author has been aware of some of the main problems inherent in product design in Botswana. These include:

- Design is carried out in a context in which supply of proprietary parts is limited;
- Long timescales are usual;

- Products often fail to work satisfactorily;
- A reliance on testing of prototypes to determine whether the design will work; there is a need to analyse and evaluate designs earlier than the prototype stage to avoid prolonged periods of modifications.
- Although the design of prototypes may be managed by product design engineers, the prevalent organisational structure results in some of the phases of the product design process often being carried out by teams of people not directly reporting to the product design engineer i.e. there is a tendency for a dis-joined design team.

Pugh (1991, p. 5) stresses that:

“All design starts, or should start, with a need that, when satisfied, will fit into an existing market or create a market of its own.”

In particular, product design requires technology deployment (Akao et. al, 1990). Schumacher (1973) established the expression “Intermediate Technology” (ITech) to describe a new technology suitable for the least economically developed countries (LDC) that may represent economic growth relative to “Appropriate Technology” (ATech; Table 1) or downscaling from productive technology of the most economically developed countries (MDC). A culture of productivity is required to promote a visible, coherent and adaptable work structure that integrates all activities of organisational teams for tackling the national problems and detailed descriptions of how employees organise their experience to achieve productive accomplishments are achieved within particular settings are still needed (Akin and Hopelain, 1986); such a culture of productivity developed by organisational teams may be established to finding solutions to the problems that are more prevalent in the LDC. Through co-ordinated participation of design teams in organisations, structured product design activities can open opportunities to expand the markets of the LDC as well as economic transformation resulting from an increased number of tradable commodities; these are some of the national economic concerns in Botswana as identified by the Vision 2016 Taskforce (1997).

Appropriate Technology (ATech)	Intermediate Technology (ITech)
Provides questionable solution i.e. the solution has potential to cause additional problems more especially within a network solutions.	Engages the whole problem i.e. the Solution is complete and is viewed as a potential within other possible solutions.
Bear no relationship to the market leading technology and have no timing or forecasting for its introduction.	Result from a purposeful strategy to lag behind technology developed by market leaders to affect the timing of innovation adoption and impose lower adoption cost to customers.

Table 1: Summarised Differences between Appropriate Technology and Intermediate Technology

1.1.1 Market Opportunities

Product design can assist to establish, maintain and expand both national and international markets for the LDC by contributing towards industrial development; this entails initially addressing the needs of a single country followed by the establishment of a sphere of influence that may increase to regional and continental markets. Botswana is a case in point. Whitby (1985) categorised the basic needs of Botswana and other LDC as follows (Table 2):

1. Water and Sanitation	2. Employment	3. Energy
a. Water Collection b. Water Conservation a. Water Supply	b. Small Scale Industry c. Income Generation Activities	a. Cooking b. Warmth d. Lighting
4. Food Nutrition and Health	5. Building and Construction	6. Transport
a. Food Production b. Food Processing a. Food Storage	a. Low Cost Housing b. Building Materials e.g. Clay and Paint	a. Animal Drawn Carts b. Bicycle c. Road

Table 2: Categories of Basic Needs of the Least Economically Developed Countries (Source: Adapted from Whitby, 1985)

An example may be cited on the approaches that have been used to address the food nutrition and health basic needs. Traditionally, it was mainly women or the female child who used a mortar and pestle to pound sorghum in preparation for the family meal. During the 1970s, the manual grain grinder wheel and the milling stones were among the other technologies which were available in Botswana. The operation of these technologies could have been laborious and time consuming and also could have driven Batswana from their preferred staple food to maize meal which was imported (Laswai et al, 2003). Following United Nations World Conference on Women held in Mexico in 1975 on gender issues, the Government of Botswana through Botswana Agricultural Marketing Board (BAMB) identified an acceptable mechanised system of processing sorghum (Pelotona, 2005).

Whilst focusing on the success of a new sorghum dehuller design in Botswana, Schmidt (1987) explains the process of “research-for-development” applied by the Rural Industries Innovation Centre (RIIC) and Botswana Agricultural Marketing Board (BAMB) through the support of the International Development Reseach Centre (IDRC) which is based in Canada. The sorghum dehuller was then diffused from Botswana to ten other African countries, namely: Lesotho, Malawi, Mali, Namibia, Senegal, South Africa, Swaziland, Tanzania, Zambia and Zimbabwe (Mmapatsi and Maleke, 1996). According to Rohrbach et. al. (2000), the sorghum dehuller is currently contracted for other countries such as South Africa and Zimbabwe although RIIC remains as the main supplier in Botswana. This demonstrates the increase in the geographical coverage to penetrate the Southern African Customs Union (SACU), Southern African Development Community (SADC) and Economic Community of West African States (ECOWAS) markets (Figure 1).

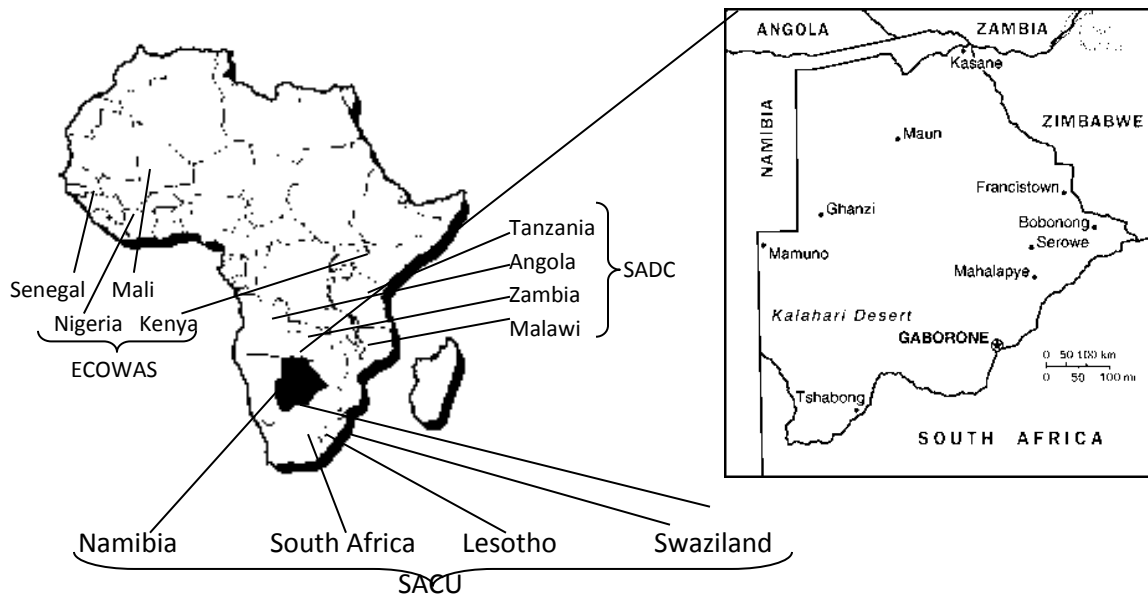

Figure 1: Location of Botswana in Africa relative to SACU, SADC and ECOWAS Member Countries where the Dehuller was Diffused

Therefore, it should be noted that the product as designed in Botswana may not be a ‘one solution fits all’; the current technologies in the importing markets must be in tune with product, which requires co-ordinated product design activities performed on a visible operational structure including possible re-designs, as well as freezing any changes to the product, to address the nuances of the basic needs in different countries (Table 1 and Figure 2).

1.1.2 Economic Transformation

Rosenberg (1976) coined the idea of "technological expectations" which is recognized by those examining the diffusion of innovation. Livingstone (1980) summarized that, the “technological expectations” of LDC revolve around the interest for the development of small, micro and medium scale enterprises (SMME) particularly in the rural industry because of:

1. Aspirations for localisation and local control of industry;
2. Emphasis on rural development;
3. A search for more labour intensive “appropriate technology” and its improvement coupled with a concern for growth of employment associated with import substitution by the formal sector – this research is particularly focusing on “intermediate technologies”; and
4. The aim to diffuse industry

There is heterogeneity in such technological expectations which may be referred to as “customer preferences” (Green et.al., 1991). A customer is an organization or person that receives a product to satisfy their needs and expectation which may be stated,

implied or obligatory (Peters, 2006); however, customer complaints are nonconformity which may arise from some latent requirement e.g. to the attitude of staff or to false claims in advertising literature (Imai, 2006). The customer requirements are implemented through the marketing process and the sales process. The marketing process is able to link through internet technology to the customer's factory for B2C (business-to-customer), e-manufacturing, e.t.c. (Halevi, 2001). The technology adoption lifecycle (TAL) is a statistical normal curve for understanding the acceptance of new technologies that divides the market into five segments, each occupying a single standard deviation: innovator, early adopter, early majority, late majority and a laggard (Moore, 1991a, 1998b; Figure 2); with the early majority and late majority straddling the mean (occupying an enormous two-thirds of the market).

The development of SMMEs should therefore be through a visible business operational structure that has product design at its core. Such a SMME – oriented development is two fold:

1. The SMME entity should have its business designed as a productive workspace where employees integrate their knowledge and experience in product design to realise the intended business goals; and
2. The collective action of several SMME should be designed such that they collectively and productively contribute in a complementary manner to the business goals through the TAL based on the fact that each market segment has a different set of customer preferences i.e. it should be realised that markets, as segmented and served by the SMME, should have the emerging characteristics similar to the TAL.

Hence, product design activity is inevitably intertwined with business design activity (Pugh, 1991).

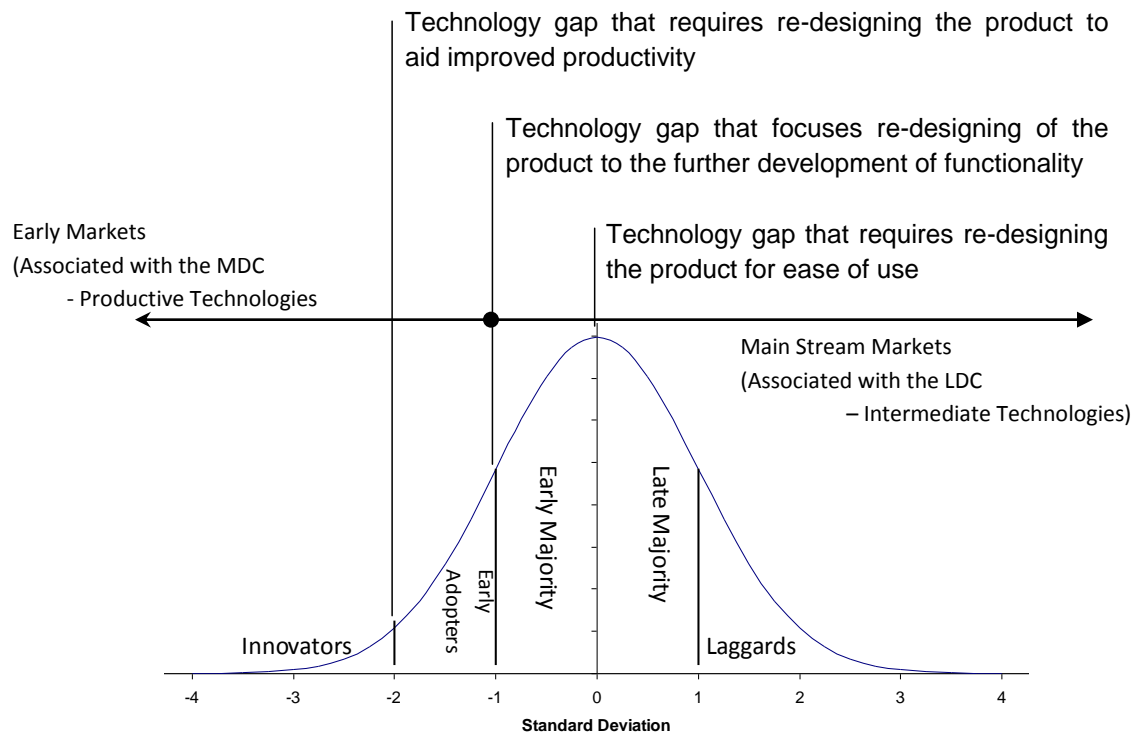

Figure 2: Technology Adoption Lifecycle (Source: Adapted from Moore, 1998)

The market segments are delimited by chasms identifiable by technology gaps which signal the needs for innovative re-design (represented by a line at every standard deviation) and any technology transfer between the market segments should diffuse by “crossing the chasm” starting from the innovators and develop its market sequentially towards the laggards. Re-designing a product may lead to diversity depending on factors identifiable in a market segment. Henderson and Clark (1990) identify four types of innovative re-design strategies that depend on relationships between (product) components which may be useful to “cross the chasm” (Table 3). Of the four chasms that have to be crossed between market segments, the largest chasm occurs between the early adopters and the early majority; signalling the fact that the nature of those factors that account for technology acceptance by the innovators and the early adopters are appreciably different from those required in the early majority, late majority and the laggards – this largest chasm is referred to as the Intermediate Technology (ITech) gap in this research work. From Table 1, it would appear that intermediate technology may be associated with the early majority, late majority and the laggards taken together as a group as indicated in Figure 2.

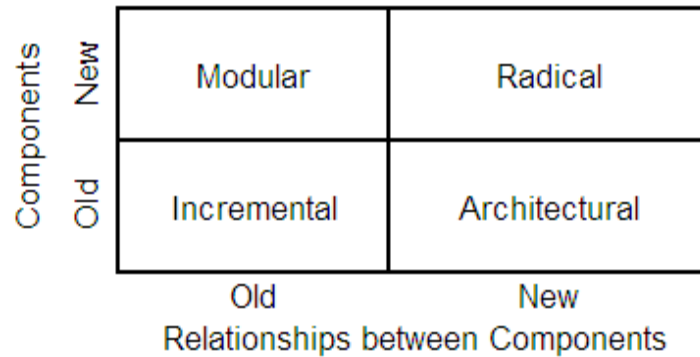

Table 3: Innovative Re-Design Strategies

Both Pugh (1991) and Cross (1994) posited that whilst the overall product design process is convergent, there was need to adopt a strategy of “controlled convergence” and “deliberate divergence” at specific intervals while executing the product design activities. On the other hand, Otto and Wood (1999, 2001) and Wood and Linsey (2007) acknowledge that the product design process has a need – function – form structure. Although these strategies have not received clear research attention with respect to techniques applied within the product design process, the work of Sroufe et al. (2000) looks at how the design process can be effective in the diffusion of new products to “cross the chasm” in environmentally responsible manufacturing firms.

The diffusion of the sorghum milling technology (with dehuller and hammermill as the principal products) in Botswana and SADC market may show a similar trend; the research work done by Rohrbach et. al. (2000, 2007) may be used to contrast the diffusion of the sorghum milling technologies between African countries whose similarity is the interest on the relationship between technology, investment, and grain supply.

Firstly, attention may be drawn to the growth and economic transformation of cereal mills in Botswana over a period of two decades (Table 4). There was growth in terms of number of sorghum mills, their size and type of operation. The markets also grew from rural areas to include urban areas as well as technological transformation forced by the introduction of new crops being processed.

Year	Number of Mills		Size		Crop Competitiveness	Type of Operation	Markets
	New	Cumulative		kg/h			
1979	2 (Prototypes)	0	Small Scale	100	Sorghum	Validation Tests	
1980 - 1984	20	20	Small and Micro Scale	300	Sorghum	Service Milling i.e. No Grain is bought and No Product is Sold	Rural Areas
1985 - 1989	13	33	Small and Micro Scale		Sorghum		Rural Areas
1990 - 1994	41	74	Small, Micro and Medium Scale	> 300	Sorghum	Commercial Milling i.e. Grain is Bought and the Products Sold	Rural and Urban Areas
1995 - 1999	89	163			Sorghum and Maize		Rural and Urban Areas

Table 4: Growth and Economic Transformation of Cereal Mills in Botswana (Adapted from Rohrbach et. al., 2000)

Secondly, the rate of establishing cereal mills differs in the different African countries because of the following factors:

1. The relative strength of consumer demand for sorghum flour;

2. The cereal milling technology was readily available;
3. The magnitude of government financial support for development of the industry;
4. The reduction of import barriers for grain; and
5. The reliable and readily available quality grain necessary to operate throughout the year.

In Botswana, cereal mills were highly successful because there was high demand for sorghum flour and the technology was boosted by technical support from both the RIIC and Financial Assistance Policy (FAP) offered by the Botswana Government which also significantly simplified the importation of grain (this is because Botswana produces low quantities of cereals from agriculture and the government allowed the entrepreneurs to personally negotiate with the grain supplier irrespective of whether they were in Botswana or not).

Sorghum milling is more pervasive because the technology was designed locally and is available at RIIC; but technologies for maize are not as available and a re-design is necessary and is yet to be done. At the time of writing this thesis, a semi-automated sorghum mill with an output of 2500 kg/hr had been installed by RIIC in Botswana and the diversity of products have increased to include food fortification through a double ribbon reversible mixer designed in 2004 in collaboration with the National Food Technology Research Centre (NFTRC); both RIIC and NFTRC are conducting research to introduce the milling of legumes – a fact that would require another re-design. The product design methods that are used by both RIIC and NFTRC need to improve their responsiveness towards coping with the rate of re-designs necessary for cereal milling; Furthermore, the economic transformation resulting from increased crop milling should be noted.

Although the sorghum milling technology is very productive and was adopted through assistance from Canada, a most economically developed country (MDC), the technology is only likely to cross the chasm into other African countries if these factors are addressed.

Glass and Saggi (1998) had put together a model that seeks to place ITech as part of TAL by linking foreign direct investment (FDI) and technology transfer from the most economically developed countries (MDC) to the least economically developed countries (LDC) (Figure 2). Although Figure 2 shows an over simplified situation, the diffusion of technologies may require segmentation of countries into markets along the TAL; to “cross the chasm” product designers need to re-design products within and across industries thereby transforming the economic base of countries.

This research is interested in successful product design methods such as the “research-for-development” not only because of their positive impact on national trade deficits but most importantly to develop guidelines that benefit from other equally effective product

design methods. This work also tries to understand the applications of the “controlled convergence” and “deliberate divergence” within such successful product design methods – the introduction of different grains requires re-design of the original sorghum milling technologies and is done in part as a case study (Chapter 6).

1.2 Justification for the Research

This thesis has a practical and an educational relevance. The most important is the relevance to the industrial product design practice. This research would add or extend the knowledge on the work of Schumacher (1973), Livingstone (1979), Whitby (1985), Schmidt (1987) and Botswana Vision 2016 Taskforce (1997) all of who argue for increased research on intermediate technologies to address the needs of the least economically developed countries. These needs are physically manifested as appropriate technologies (ATech) which are indigenous to these countries as well as their imports of productive, though unsuitable, technologies which are successful in the most economically developed countries. Engineering literature is scarce on how the product design processes can contribute in this regard; this thesis attempts to fill that gap.

The educational relevance can be found in the fact that there are several product design method already in the public domain and taught in educational institutions. The teaching of these product design methods could benefit from increased analysis of their structure as hypothesised by Pugh (1991) and Cross (1994). If these hypotheses can be supported, the educational relevance would be the development of product design guidelines with constructive consequences to syllabi.

1.2.1 Novelty (Statement of the Problem)

In their investigation of the relationship between poor economic performances as signalled by the growth of gross domestic product (GDP) and low rates of investment (both public and private Investment) in African countries, Devarajan et. al. (2001) established that Botswana, Comoros, Equatorial Guinea, Lesotho, Mozambique, Sao Tome and Zambia were outliers; they found that the relationship was non-linear and that low investment as well as low performance growth rates seemed to be symptoms of the following five factors – all of which must be addressed concurrently and not in isolation (Figure 3).

1. Low usage of available capacity;
2. Limited absorption of acquired skills;
3. Loss of highly productive sectors (into low productivity);
4. The existence of state-owned enterprises; and
5. Poor policies.

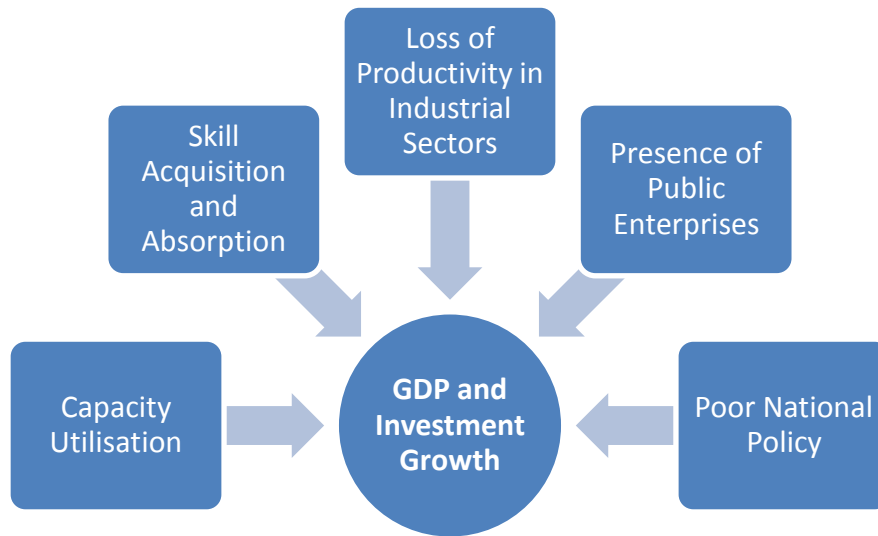

Figure 3: Components of GDP and Investment Growth

In the case of Botswana, this fact had long been noticed by Whitby (1985) who established that technology development and transfer is both isolated and uncoordinated resulting in very few intermediate technologies which emanate from scattered industrial sectors. This situation still prevails today.

The Vision 2016 Taskforce (1997, p. 8) have observed that Botswana has:

“has set itself a low benchmark by comparing itself with poor countries, rather than with the best in the world.”

Thus the question of devising or adopting appropriate technologies does not match the economic success of Botswana; then, a question that arises is how to benchmark “the best in the world”?

A core approach would be to enhance national capabilities to develop, adapt and apply technologies suitable for small, micro and medium enterprises (SMME) processing and manufacturing industry and to develop technology forecasting systems and training programmes to strengthen national manpower (Botswana Technology Centre, 1998). This approach identifies bringing in technology management systems to document and direct technology development, technology adaptation and technology application. Some national technology development and transfer programmes continue to bear fruit in support of SMME (Ministry of Finance and Development Planning, 2002).

The current growth of SMMEs might reflect the declining importance of centralized mass production which has, in some industries, favoured the flexibility and specialisation that small firms can offer (Jefferis, n.d.). Therefore citizen entrepreneurship and empowerment should be encouraged for the development of competitive and sustainable SMMEs (Ministry of Commerce and Industry, 1999). The main role of SMMEs in technology transfer could be in the manufacturing of the

products that have been locally designed (Chanda, 1999) and attendance of training programmes (Moyo, 1999). The epoch to intensify programmes for technology based incubators has also begun (Changeta, 2003). These responses may indicate the pressure to have product development processes that incorporate and link the design processes in research, science, technology and innovation institutions (RSTI) to the manufacturing processes of SMMEs.

The body of knowledge in intermediate technology still incomplete and needs to be increased to adequately address the factors that lead to low GDP and investment growth in the LCD (Figure 3). If countries such as Botswana want to diversify their economies through product design, then Pugh (1991, p. 5 and p. 176) citing Akin and Hopelain (1986) advocates for a “culture of productivity” demonstrated by a “visible” product delivery process (PDP) where the product design activities from the various stakeholders are integrated or unified using product design as a central theme; furthermore, “visibility helps everyone to find out what people are doing and why”. This research addresses one way by which this could be achieved in a least economically developed country.

According to Beintema et. al (2004) and Teng-Zeng (2007) three of the main research, science, technology and innovation institutions (RSTI) in Botswana, namely: the Rural Industries Promotions Company (Botswana) [RIPCO (B)], the Botswana Technology Centre (BoTeC) and the National Food Technology Research Centre (NFTRC) were all established as part of technology transfer programmes between Botswana and Europe (Germany and United Kingdom, respectively) in the mid-1970s. When these RSTI were established, they were, and still are, supported by different ministries of the Botswana Government (Figure 4).

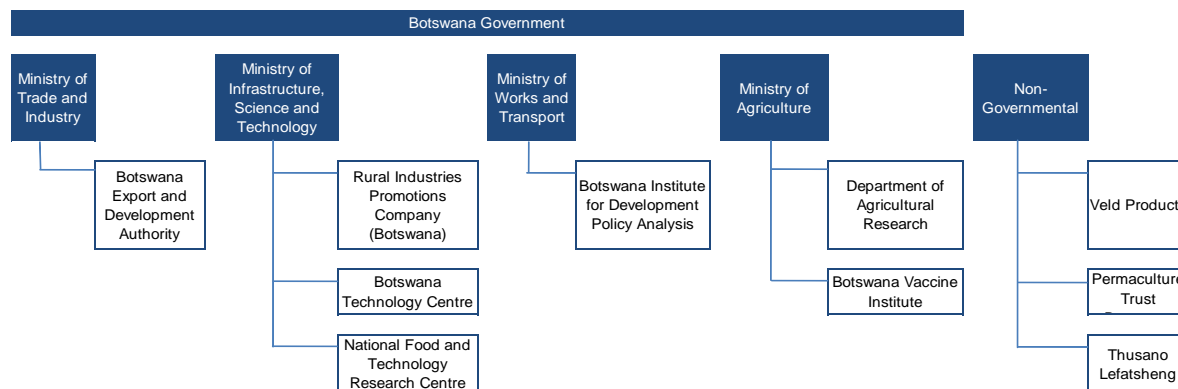

Figure 4: Research, Science, Technology and Innovation Institutions in Botswana

This study, under sponsorship of the Department of Science, Research and Technology (DSRT), intends to expand this collaboration by proposing engineering product design guidelines that successfully incorporate product design methodologies developed and taught in America (Canada and USA), Asia (Japan and Russia) and Europe (Germany

and the United Kingdom [UK]) as a vehicle for technology transfer within the perspectives of intermediate technology.

The following claims are made for contributions to knowledge:

1. The conceptual framework which is a graphical co-ordinate system of the most engineering and management techniques used by designers to carry out the product design activities. The conceptual framework is arranged according to two orthogonal axes that describe the structure of product design process namely, the need – function – form structure and the divergent – convergent structure. In addition, the conceptual framework takes account of the product design drivers, product realisation process and the product development lifecycles.
2. The product design method notation which is a register of the expression derived from the conceptual framework and used to denote a group of techniques being implemented, or intended for implementation. Such expressions are henceforth referred to as product design procedures and aid in the selection as well as communication of these product design procedures among the design team; and
3. The configuration scheme which provides a clear link between components, sub-assemblies, products, projects, programmes and policies.

1.3 Research Questions

The engineering design process could involve complicated factors, changing expectations and the effect of indirect influences, and its effectiveness might be difficult to assess (Crispin, 1987). The following research questions were developed looking in particular at the problems faced by engineering product designers in Botswana and the United Kingdom; the World Bank classifies these countries Least Economically Developed Country (LDC) and Most Economically Developed Country (MDC) respectively:

Research Question 1: How might engineering product design establishments shorten the time to market in particular through circumventing long delays in prototyping works?

Research Question 2: Which product design approach can, or could be devised to, allay constraints caused by the discrepancy between technology development, or transfer, and product design?

Research Question 3: What approaches can aid the engineering product designers to cope with, or to contribute to, the development of local Original Equipment Manufacturers (OEM) who constitute the supply chain of parts and to simplify the design process by availing off the shelf products?

The following two hypotheses will be used to suggest answers to these research questions:

Hypothesis H₁: Product design methods creatively utilise a common set of rules or principles to interchangeably manipulate specific subsets of the attributes in accordance with the “controlled convergence” and “deliberate divergence” product design strategies as posited by Pugh (1991) and Cross (1994); and

Hypothesis H₂: the basic structure of the product design methods uses a common set of attributes defined by the need-function-form structure as posited by Otto and Wood (1999, 2001) as well as Wood and Linsey (2007).

1.4 Research Programme

With the exception of Chapter 1, 2 and 7, the thesis mirrors the work schedule that was used in this research which is divided in to two groups of chapters (Figure 5):

Chapter Group #1. The Product Design Guidelines Set-Up comprised of Chapter 3, 4 and 5; and

Chapter Group #2. The Product Design Guideline Implementation which is further sub-divided in two activity segments:

Activity Segment # 1.: The Industrial Case Applications comprised of Chapter 6;

Activity Segment # 2.: The Diffusion Activities comprised of a Study Practical Trip to Botswana.

1.4.1 Chapter Group #1

The research programme starts with an initialization and planning stage for conducting a literature review which generated a research focus into the following engineering methodologies chosen according their impact indicated by citation metrics (Section 2.5):

1. Methods that are acknowledged to originate from North America were Axiomatic Design (United States of America [USA]) and Stage-Gate New Product Development (Canada);
2. Methods that are acknowledged to originate from Europe were Systematic Engineering Design Approach otherwise known as Pahl and Beitz Method (Germany), Teoriya Resheniya Izobratatelskikh Zadatch or TRIZ (Russia) and Total Design (United Kingdom [UK])
3. Methods that are acknowledged to originate from Asia were Quality Function Deployment (Japan) and Taguchi Methods otherwise known as Robust Design (Japan).
4. The Reverse Engineering and Re-Design is an almost universal method that mixes aspects from all of the above methods; it is difficult to say exactly its origin.

Specifically, the Chapter Group #1 deals with the following research activities:

Literature Review (Chapter 3): Secondary data on engineering product design methodologies were examined and used for proposal write up. Based on the literature review, a proposal for literature-based product design guidelines was developed using qualitative analysis methods by the end of 2008.

Analysis (Chapter 4): This activity ran concurrently with the literature review.

In March 2008, exploratory data collection was conducted in Botswana in which eleven RSTIs were identified and information on their industrial sector, mandate, number of employees, year of achievement and their socio-economically major projects was gathered. A pilot questionnaire was administered at Loughborough University (LU) at the last quarter of 2008.

The key dimensions emanating from the literature review to answer the research question were used to develop product design guidelines. From January 2009 to June 2009, the proposal for literature-based engineering product design guidelines was validated at the Rural Industries Promotions Company (Botswana) [RIPCO (B)]. At the same time, a questionnaire was administered to gather data on the product design methods used by three institutions in Botswana. The same questionnaire was administered to one company based in the United Kingdom. Based on the responses from these companies, a proposal for an industry based product design guidelines was developed using qualitative analysis methods.

Product Design Guidelines Set – Up (Chapter 5): The literature-based and industry-based proposals of the product design guidelines were consolidated and the principles for using the guidelines were documented.

1.4.2 Chapter Group #2

Since this research is conducted as part of the “Training of Scientists and Technologies” project of the Ministry of Infrastructure, Science and Technology (MIST) in Botswana, the Rural Industries Promotions Company (Botswana) [RIPCO (B)], which is a collaborating or supporting institution whose portfolio is overseen by MIST, was selected for all activities in this sub-section.

Case Examples by Applying the Product Design Guidelines in Botswana (Chapter 6): From July to August 2010 and for the period between March to April 2011, the consolidated product design guidelines were validated and diffused at Rural Industries Promotions Company (Botswana) [RIPCO (B)].

Diffusion: Several product design reviews and presentations of the product design guidelines were ongoing for the study practical trips made to Botswana. A presentation was prepared for a research student conference in June 2009.

1.5 Delimitation

This research aims to study the product design methods used by RSTI which are directly supported by the Ministry of Infrastructure, Science and Technology [MIST] (Figure 4). Any case study work would be done in collaboration with, or through the support of, the Rural Industries Promotions Company (Botswana) [RIPCO (B)]. This is so as to enable logistic support for the researcher; however, this also imposes resource constraints that are available for this research work.

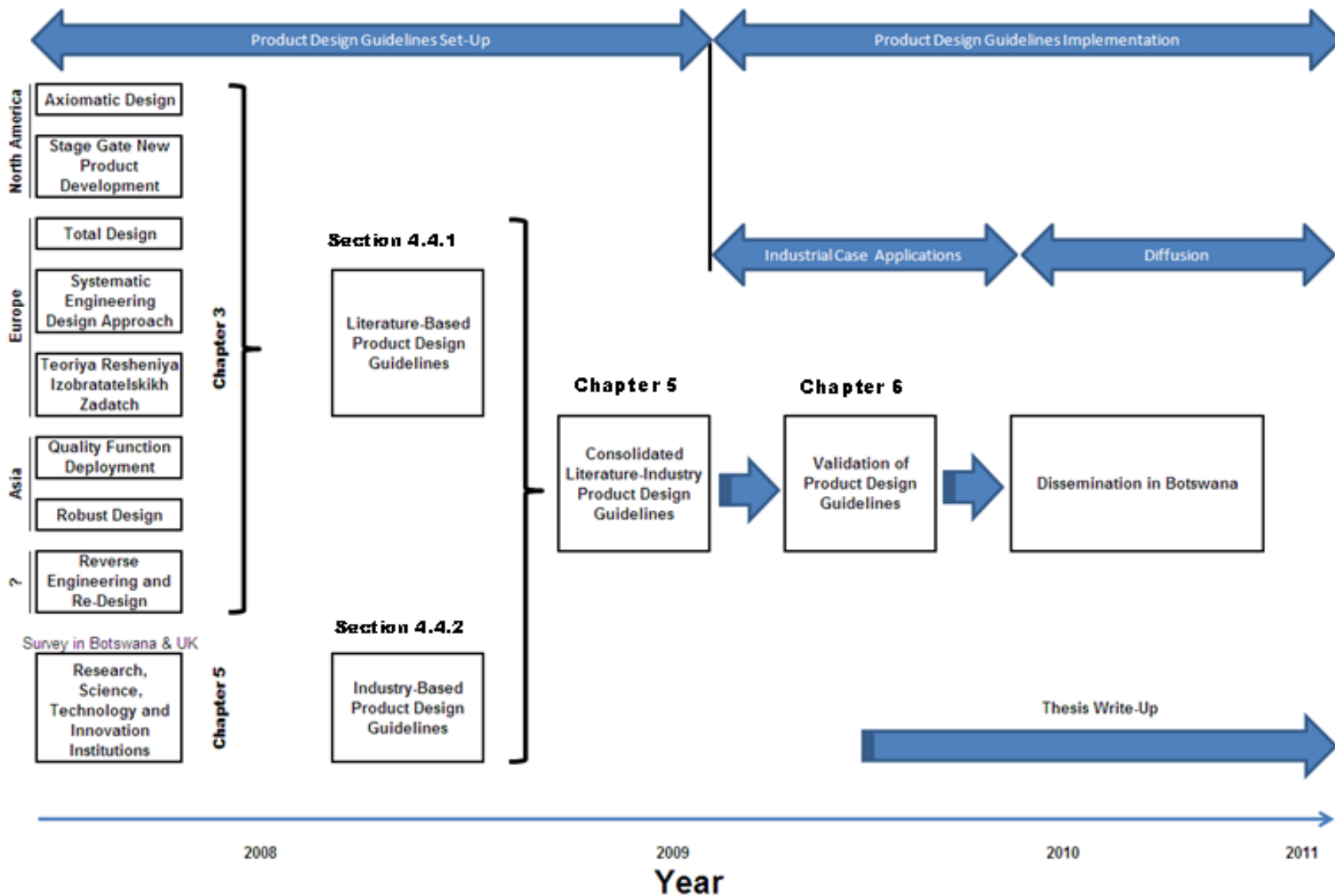

Figure 5: Research Programme

1.6 Thesis Discourse

The arrangement and information flow between the thesis chapters the thesis is illustrated in Table 5.

<p>Chapter 1:</p> <p>Introduction</p> <p>An expression of the research context focusing on the setting and motivation as well as the presentation of research questions and programme.</p>
<p>Chapter 2:</p> <p>Research Method</p> <p>A specification of research design, sampling technique, data collection procedure, data analysis method with data presentation tools, possible error sources and mitigation plan.</p>
<p>Chapter 3:</p> <p>Engineering Product Design Methodologies Documented in Literature</p> <p>A presentation of documented types of product design methods, structure of product design methods, design mapping modelling, product design activity workflow, research, science, technology and innovation institutions and examples of product failures.</p>
<p>Chapter 4:</p> <p>Engineering Product Design Guidelines</p> <p>A detailing of principles and a description of the product design guidelines proposed by this research.</p>
<p>Chapter 5:</p> <p>Survey of the Engineering Product Design Methods used in Industry</p> <p>A description of a data collection instruments, qualitative research methods and findings of this research in Botswana.</p>
<p>Chapter 6:</p> <p>Case Examples by Applying the Product Design Guidelines in Botswana</p> <p>A validation of the product design guidelines through case studies on grain or food production and processing intermediate technologies at the Rural Industries Promotions Company (Botswana).</p>
<p>Chapter 7:</p> <p>Conclusions, Recommendations and Suggestions for Future Work</p>

Table 5: Thesis Discourse

Chapter 2: Research Methodology

Introduction

This chapter describes a six step model of the research process. The six steps incorporate three research approaches to adequately address issues of bias towards objective or subjective decision making (Figure 6):

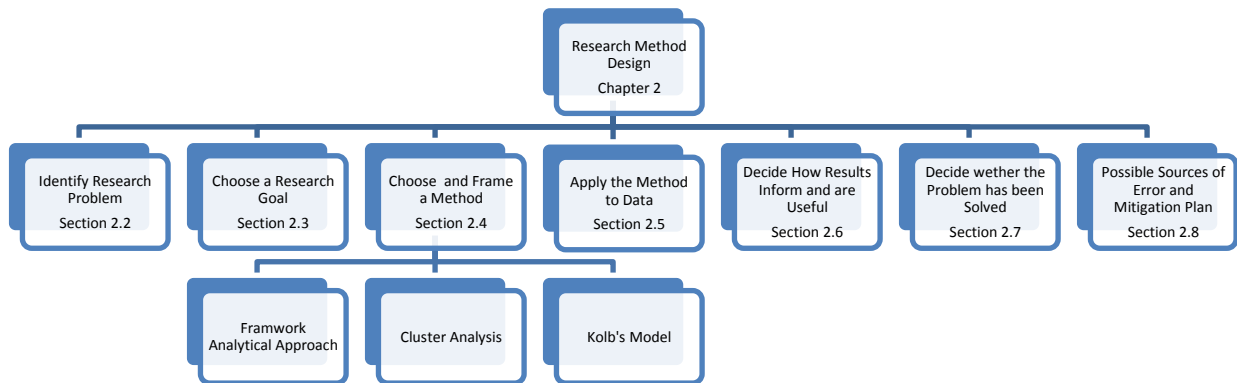

Figure 6: Research Method

Section 2.1 presents the rationalisation for adopting this research design; Section 2.2 and Section 2.3 deal with the identification of the research problem and selection of the research goal, respectively; the choice of research methods that balance the bias towards objective or subjective decision making within one another are dealt with in Section 2.4; the data collection procedures are identified together with result analysis presentation tools in section 2.5; Section 2.6 and Section 2.7 explain the counter checking measures between the identified research problem and the research goal; possible error sources and a mitigation plan are presented in Section 2.8 with a short summary in Section 2.9.

2.1 Justification of the Research Design Paradigm and Methodology

Romesburg (1984, p. 237) proposes a general model of solving research problems which is a feedback chain of six steps that link the ends and means of research design in an effort to “determine the relative roles of objective and subjective decision-making in the research process”; a feedback chain with six links that starts from the ends to the means and back to the ends again; Steps 1,2,5,6 are subjective decision-making whilst data processing methods in Steps 3 and 4 support objective decision-making (Figure 7). Objective decision making always results in an identical answer regardless of who the decision maker is, provided they are knowledgeable in how to execute the steps. On the other hand, subjective decision making produces a variety of answers and requires a consensus among the (knowledgeable) decision makers.

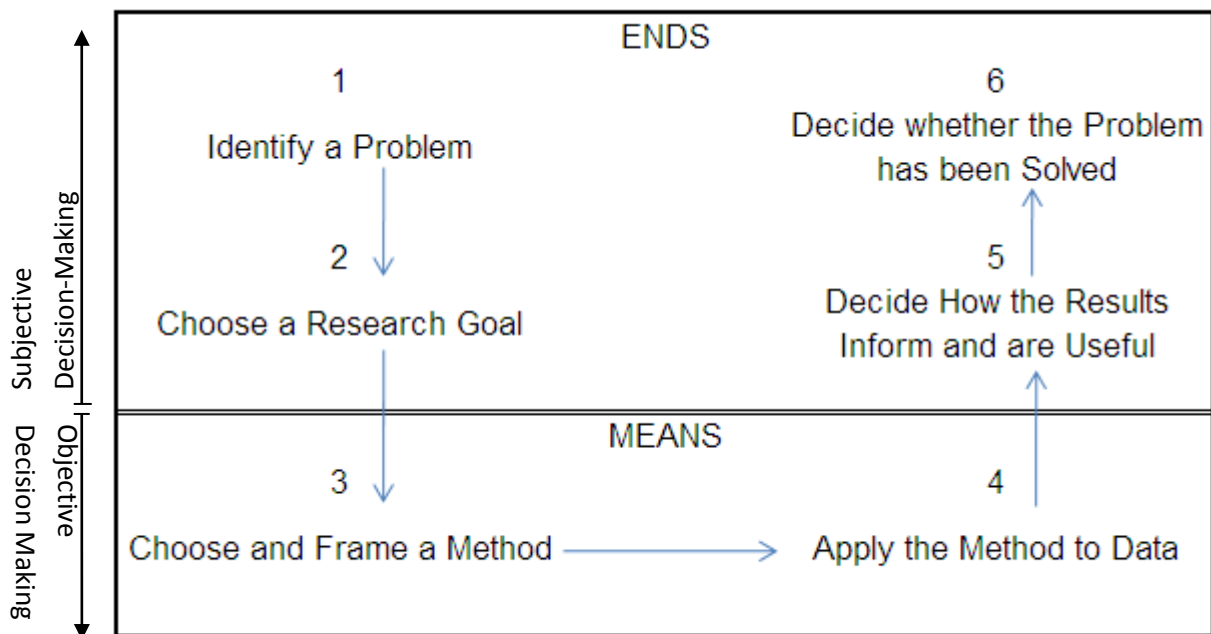

Figure 7: Research Design (Source: Romesburg, 1984)

The previous work on the approaches undertaken by international agencies teaming with the least economically developed countries (LDC) as documented by Schumacher (1973), Livingstone (1979), Whitby (1985) and Schmidt (1987) played a crucial role in the choice of the research method used in this study.

2.2 Identify a Research Problem

Livingstone (1979) recognises that during the 1970s international organisations such as United Nations Industrial Development Organisation (UNIDO) and International Labour Organisation (ILO) teamed up with the Least Economically Developed Countries (LDC) including African governments to focus attention on the development of small industries.

Botswana, in particular, benefited from the Friedrich Ebert Stiftung Foundation (FES), from Germany, through the establishment of the Rural Industries Promotion Company (Botswana) [RIPCO (B)] in 1974 and supported it for a ten years period (from 1974 - 1984) in partnership with the Botswana Government (Inger, 1993). The mandate of RIPCO (B) was to:

“advise, assist and build up rural light industry by disseminating appropriate technologies on a commercial basis. The aim was to help the people in Botswana’s rural regions who have remained poor in spite of the economic miracle because rapid growth has not alleviated social inequalities”

Despite these efforts, including the heavy investments made by Botswana Government to provide extensive infrastructure using funds from prosperous mining ventures, Botswana is still statistically ranked among the middle income least economically developed countries based on the Gross National Income (GNI) per capita (Vision 2016 Taskforce, 1997).

It is useful to decipher the formula for calculating the GNI per capita (Equation 1).

$$GNI \text{ per capita} = \frac{GNI}{\mu_{mid-year}} = f(GDP)$$

Where GNI = Gross National Income

$\mu_{mid-year}$ = The National Population Size at Middle of the Year

GDP = Gross National Product

Equation 1: Gross National Income per capita

The formula for GDP is (Equation 2):

$$GDP = PC + I + G + (eX - i)$$

Where PC = Private Consumption

I = Gross Investment

G = Government Spending

eX = Exports

i = Imports

Equation 2: Gross Domestic Product

Identified Problem: The current economic state for any country may be reflected by the GNI per capita. The ideal economic state for any country that wants to diversify its economy through product design would be to have economic measures to be reflected in its product design activities. As may be concluded from Devarajan et. al. (2001), the problem for the LDC would be gap in any of the following factors (Figure 3 and Table 2):

- 1. Consumption:** The products consumed must be designed to address the basic needs or welfare of a nation and there must be adequate absorption of such products including employment of human skills. In such a case, the

nation would be a consumer of both goods and services provided by human skill;

2. **Investment:** The increase in providing high capital per worker to boost and gain high output per worker and insure high returns from product design activities
3. **Government Expenses:** Provision of good policies, state owned enterprises that support the product design practice and lack of constraints towards acquisition of skills by product design professionals.
4. **Export:** These are all goods and services provided by citizens to foreigners; and
5. **Imports:** These are all goods and services provided by foreigners to citizens.

2.3 Choose a Research Goal

Whitby (1985) gives account of the characteristics of method to design a product so as to close an “intermediate technology (ITech) gap”; Schmidt (1987) outlines the research-for-development method that was used in such an exercise. Both note the lessons learnt and identify the areas that still require for improvement.

This research would have to investigate, identify and/or establish product design methods which are suitable for use to address ITech gap within the context of the technology adoption lifecycle (TAL) as proposed by Moore (1998) and re-design strategies suggested by Henderson and Clark (1990). This will entail establishing the key dimensions, characteristics or types of existing product design methods that are documented in literature and practiced in business.

A premise of this research is that product design is prompted by needs which it must satisfy, or the product so designed should generate a market of its own (Pugh, 1991). According to Moore (1998, p. 26 - 27), a market may be defined as:

- A set of actual or potential customers;
- For a given set of products or services;
- Who have a common set of needs or wants; and
- Who reference each other when making a buying decision

The TAL divides markets in innovators, early adopters, early majority, late majority and laggards. Between any pair of these segments is a delimitation referred to as the chasm; the chasm of interest to this research is that which occurs between the early adopters and the early majority – the ITech gap; this is because current research into the TAL suggests that the difference between needs or factors that affect the innovators and early adopters are significantly different from those that affect the early majority, late majority and laggards (Moore, 1998; Sroufe et al., 2000). Therefore, it is worthwhile to treat the TAL as having two pseudo-market segments (Figure 8).

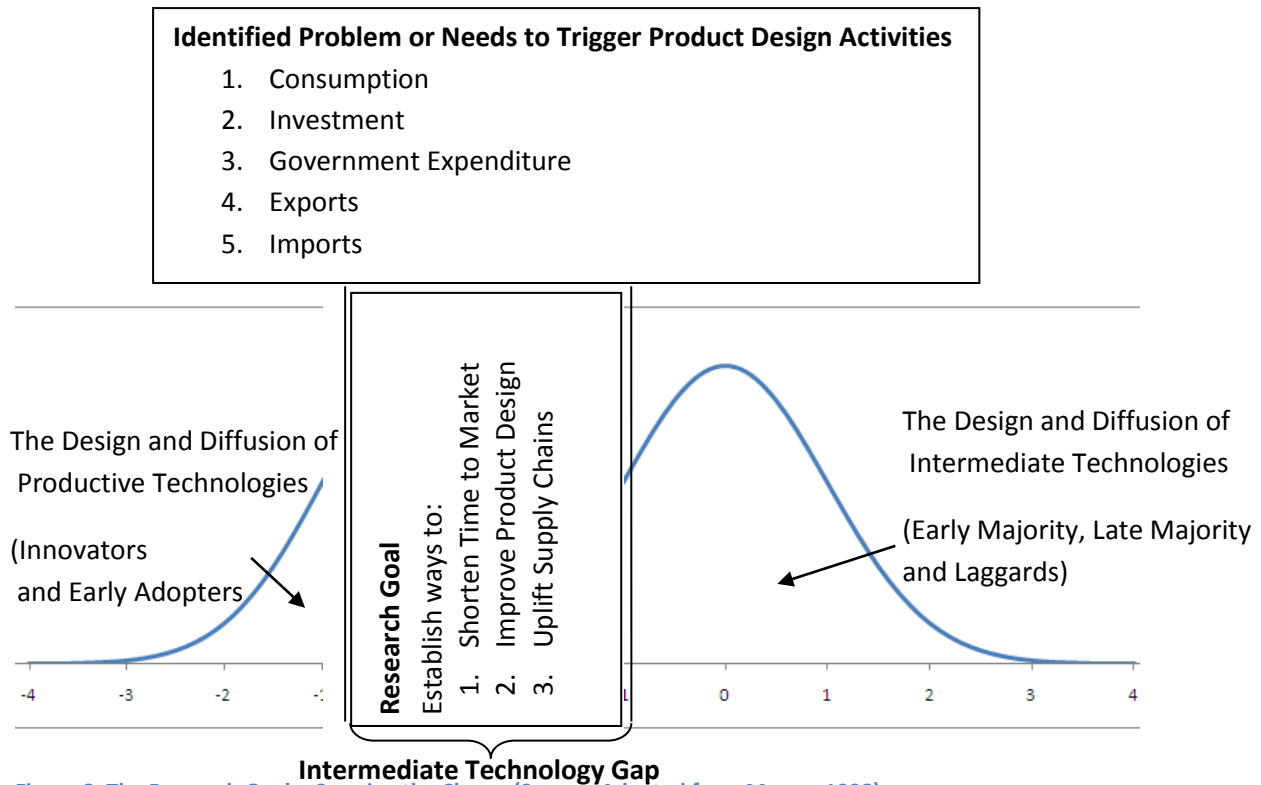

Figure 8: The Research Goal – Crossing the Chasm (Source: Adapted from Moore, 1998)

The research goal is to explore the means by which the LDC may implement product re-design strategies that target the ITech gap (Figure 8). It is evident that the “identified problem” corresponds with the future or ideal state and the research goal corresponds with the current state as identified by the “ITech gap” between the two pseudo-market segments.

2.4 Choose and Frame a Method

The actual choices that are made when selecting a research method are referred to as framing decisions and the options available to choose among are referred to as framing alternatives. The framing decisions and framing alternatives may be subjective or objective. The research goal for this study requires mapping and interpretation of the various product design methods based on identified key characteristics or dimensions. According to Ezzy (2001), interpretation plays a major role in qualitative methods; hence, the framing decisions made for this study lead to selection of the following three research approaches (this selection is a subjective choice by the researcher i.e. a different researcher could very well choose a different set of research methods):

1. Framework Analytical Approach so as to provide explanations, develop strategies, create typologies and map the range of tendencies of product design methods. These would be used to create hypotheses;
2. Cluster Analysis will be used to test the hypotheses by predicting the structure of a tree that shows the hierarchy of similarities between all pairs of different product design methods. Such a test is then validated; and

3. Kolb's model will be used as an experiential learning method for the researcher and to diffuse the findings from this study.

2.4.1 Framework Analytical Approach

Framework is an analytic approach developed in the context of applied qualitative research and has five distinct by highly interconnected key stages (Hubberman and Miles, 2002) citing Ritchie and Spencer (1994):

1. Familiarisation stage which involves reviewing and gaining an overview of the body of material gathered;
2. Thematic Framework stage where key issues, concepts and themes are identified from the data being reviewed in a process of abstraction and conceptualisation and used to develop an index or labelling mechanism.
3. Indexing which refers to a process whereby the thematic framework is applied to the data;
4. Charting whereby the indexed data is re-arranged according to appropriate thematic references denoted by headings in a grid layout; and
5. Mapping and Interpretation through which all charts are put together according to key patterns, characteristics, associations, dimensions and categories in order to create typologies, map the range of phenomena, develop strategies and provide explanations or definitions.

The framework analytical approach is almost entirely comprised of subjective decision making; hence, it may be classified as a qualitative research method. In this study it is used to generate hypotheses (Section 1.3 and Section 5.3.2.1).

2.4.2 Cluster Analysis

The hypotheses developed using the framework analytical approach would be tested using cluster analysis. An algorithm for cluster analysis adapted from Romesburg (1984, p. 9) has six steps, all of which involve objective and subjective decision making:

1. Obtain the product design methodologies toolkit data matrix;
2. Standardise the product design methodologies data matrix;
3. Compute the product design methodologies resemblance matrix;
4. Execute the clustering matrix;
5. Rearrange the product design methodologies data and resemblance matrices; and
6. Compute the co-phenetic correlation coefficient.

There are two critical steps that must be followed to use cluster analysis to test hypotheses:

1. Framing of the Hypotheses Test: This refers to the execution of the first four steps outlined above by subjectively making choices of:
 - a. Which product design methods to select;

- b. Which attributes of the product design methods to use;
 - c. How to scale the measurement of the attributes;
 - d. Whether or not to standardise the data matrix;
 - e. Which resemblance coefficient to use;
 - f. Which type of clustering method to use; and
 - g. The decision on where to cut the tree i.e. dendrogram to reflect on the level of similarity
2. Validation of the Hypotheses Test: The validating criteria would be would be similarities between the dendograms made for individual product design methods. The final two steps i.e. Step 5 and 6 would help to make the evaluation whether the hypotheses have been validated.

The actual development of the data matrix, resemblance coefficient, type of clustering method requires objective decision making and would be conducted using Statistical Package for the Social Sciences (SPSS); this compensates for the subjective decision making of the framework analytical approach.

2.4.3 Kolb's Model

It is felt that Kolb's model offers a good paradigm for design teaching and learning. Kolb's model has been used by some researchers to teach engineering design (Harb et. al, 1993; Sharp et. al., 1997; Otto and Wood, 2001; Lemons et. al., 2010).

Kolb's model is comprised of two cycles superimposed on one another (Figure 9):

1. The cycle of activity stages; and
2. The cycle of learning styles.

The activity stages occur as polarities of a continuum:

1. Perception Continuum which describes the emotional response towards the experience and illustrated by the vertical axis in Figure 9 showing the transmission of 'concrete experience' through 'feeling' to develop 'abstract hypothesis and conceptualisation' through 'thinking'; and
2. Processing continuum which describes how the task is to be approached and illustrated by the horizontal axis in Figure 9 showing gaining experience by doing 'active experimentation' or by watching to make 'reflective observation'.

The learning style cycle answers the questions associated with 'Why?', 'What?', 'How?' and 'What If?' and may be intuitively placed in quadrants as depicted in Figure 9. Thus the quadrants when associated with the four activity stages are useful for setting teaching or learning objectives. Four types of learners are associated with these teaching or learning objectives (Table 6):

1. Diverging Learner;
2. Assimilating Learner;
3. Converging Learner; and
4. Accommodating Learner

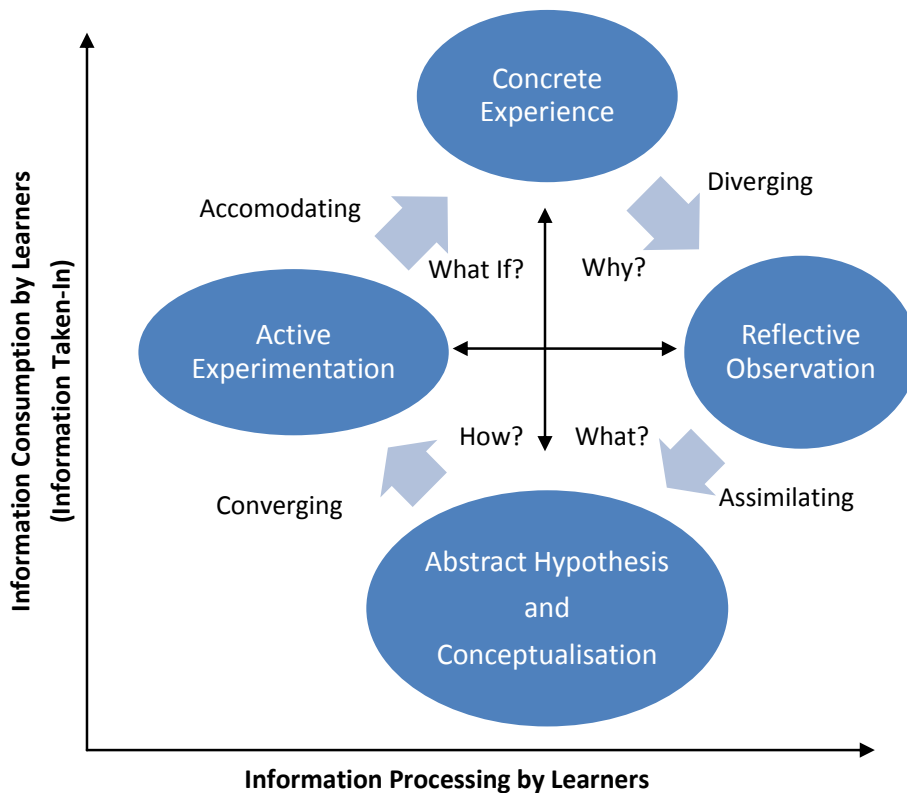

Figure 9: Kolb's Model

Table 6 shows the behavioural tendencies of each learner type with respect to free-writing i.e. is writing to one self where the purpose is to think through a problem or to generate ideas without the usual constraints of style or grammar (Sharp et. al, 1997).

<p>Accommodating Learner</p> <ol style="list-style-type: none"> 1. Exploring 2. Synthesis to explore and improve something 	<p>Diverging Learner</p> <ol style="list-style-type: none"> 1. Sharing 2. Generating Ideas
<p>Converging Learner</p> <ol style="list-style-type: none"> 1. Purpose 	<p>Assimilating Learner</p> <ol style="list-style-type: none"> 1. Comprehension 2. Analysis 3. Pros and Cons

Table 6: Types of Learners and their Characteristics with respect to Freewriting (Source: Sharp et. al., 1997)

Because the hypothesis would have been established by the Framework analytical approach, the starting point for using the Kolb's model in this study will be the 'How?' quadrant; in this case, 'How are products currently being designed?' to establish whether there are policies and organisations established that are directly responsible for product design practice and the methods that they use.

2.5 Apply the Method to Data

The main methods of data collection for this research were the following instruments:

1. Observations

2. Interviews
 - a. Pilot
 - b. Face to Face
 - c. Telephone
3. Questionnaire
 - a. e-mail / Self Completion
4. Secondary Data
 - a. Textbooks
 - b. Professional Codes of Conduct
 - c. Documented Company Procedures
 - d. Internet
 - e. Journals

Research works are generally published in journals, books, thesis, conference papers and recorded or stored in a database which any researcher can use normally through the internet and library. Citations are references to research works published in journals, books, conference papers by other authors. Citations present two types of information useful for research:

1. Cited references are those which has been used by an author whose research work is being read and which have been placed at the end of the work being read; and
2. Citing references are those which have cited the research work being read.

These assist in placing the research work being read within a particular academic context provided the research being done searches for information through the citations. Cited references enables knowledge about what other authors are saying about the original research work and the direction which the research is following. The idea behind knowledge that has been gained through such means is that, the research works with more citations would appear to be more important for both positive and negative criticism. This fact is helpful in selecting those research works with the highest potential for assisting in reaching the research goal of this study.

There are software which have been developed to assist researchers perform citation searches. These include Web of Science, Harzing's Publish or Perish and Highwire. Each of these use citation metrics which are used to produce an output in the form of a citation report and citation map; the citation map showing the research work and the cited references is called backward citation mapping and the one showing the citing references is called forward citation map (Figure 11). The backward citation map for this research would be similar to the research programme (Section 1.4).

The citation searching software function through a complementary database which stores the research papers. Such databases include US Patent and Trademark Office, Google Scholar, Science Direct, IEEE Xplore, Scitation / Spin Web, PROLA and Scopus (Roth, 2005).

The selection of documents to which are referenced in the thesis were based on citation metrics determined by using Harzing's Publish or Perish software and Google Scholar database. According to Harzing (2010), the citation metrics with regards to the author, publisher and the journal are as follows (Figure 10):

- Total number of research papers;
- Total number of citing references;
- Average number of citing references per research paper;
- Hirsch's h-index which denotes that out of N_p research papers published by the author, h/N_p have at least h citations each, and the other (N_p-h) papers have less than h citations each.;
- Zhang's e-index;
- Egghe's g-index which shows the largest number such that the top g articles ranked in decreasing order of the number of citations that they received (together) received at least g^2 citations.;
- Contemporary h-index; and
- Age-weighted citation rate.

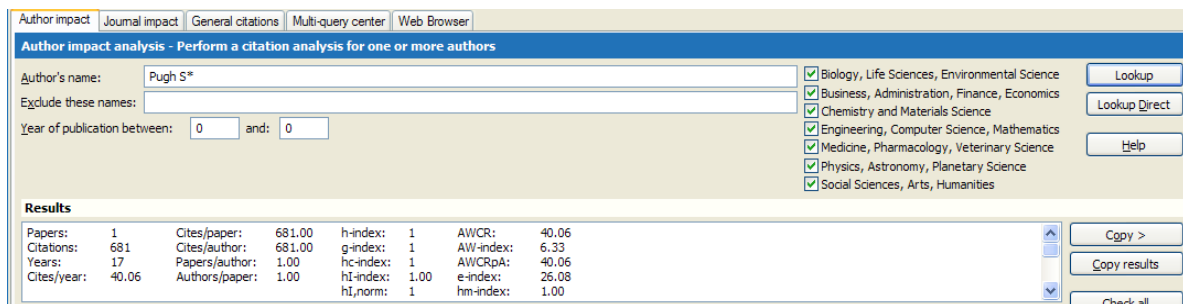
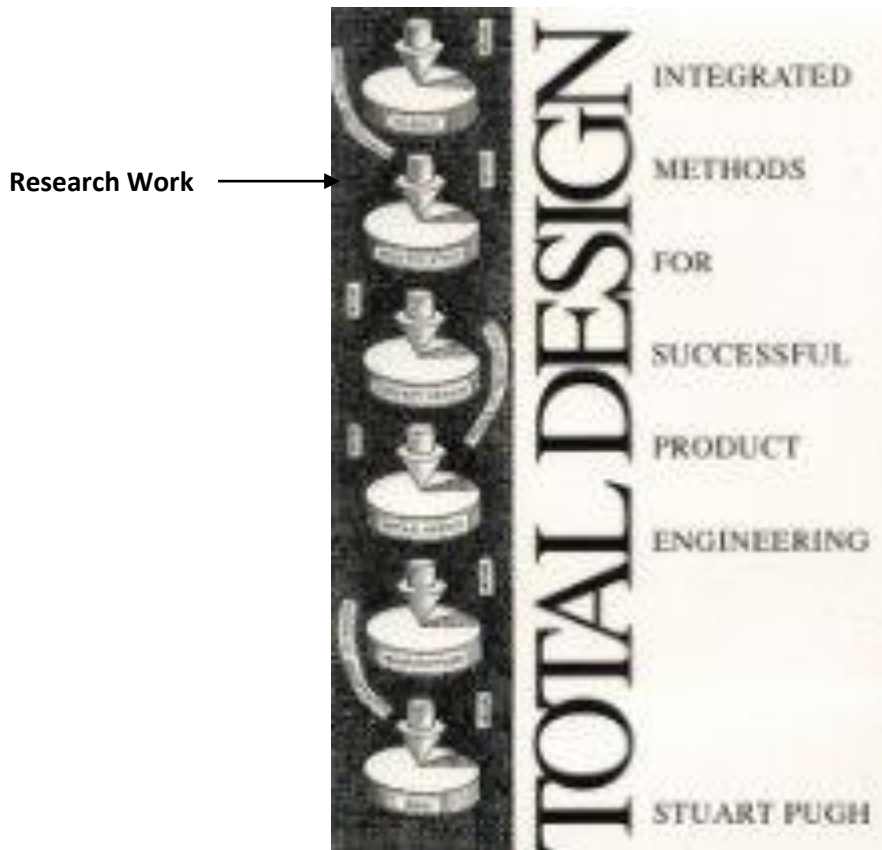
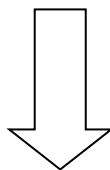

Figure 10: Citation Metrics from Harzing's Publish or Perish



Research Work →

Citing References



[\[BOOK\] Total design: integrated methods for successful product engineering](#)

S Pugh - 1995 - lavoisier.fr

Based around a core of **design** activities, this book presents the **design** function as a systematic and disciplined process, the objective of which is to create innovative products that satisfy customer needs. The author is widely regarded as a foremost authority on an integrated approach ...

[Cited by 681](#) - [Related articles](#) - [Cached](#) - [SFX](#) - [Library Search](#) - [All 5 versions](#)

↑
Number of Citing Reference

Figure 11: Forward Citation Map developed through Google Scholar Database

The cited and citing reference, including bibliographies, which are relevant to the research goal, were among the first research works to be examined in this study. The above three research methods will be applied to analyse the data collected through these standards instruments and presented in a number of ways including charts, tree diagrams (dendograms) and flowcharts.

2.6 Decide on how Results Inform and are Useful

The results from data analysis must be checked any errors resulting from wrongfully applying the research methods i.e. technical correctness. The results must also be checked against the validation criteria established with the cluster analysis research method and also any emergent issues must be noted.

2.7 Decide whether the Research Problem has been Solved

A confirmation as to whether the right research goal was specified for the identified problem and whether the context of the research has been adequately clarified.

2.8 Possible Sources of Error and Mitigation Plan

There are three possible problems with these types of data collection methods: internet access, sampling, response rates:

1. Although internet use is growing, not all members of the population might have access to reliable e-mail and the internet and are therefore automatically excluded;
2. The response rates to questionnaires used for surveys are known to be notoriously low ; and
3. Subjectivity is necessary for this research to progress; the following framing decisions have conditioned the data analysis:
 - 3.1. The choice of the eight product design methodologies;
 - 3.2. The choice of attributes, and their scales of measurement, to compare the eight product design methodologies;
 - 3.3. The choice of resemblance coefficients and the clustering method

Enumerators were sought to help to collect data in Botswana and practical trips were scheduled in March 2008, January – June 2009 and July – August 2010.

This research, whilst being short-term, should be viewed as part of the longer-term research of the Botswana Research, Science and Technology Plan (BNRSTP) which was prepared in 2005 in terms of which Ministry of Infrastructure, Science and Technology (MIST) simultaneously sponsored about ten postgraduate researchers from the RSTIs under its portfolio (Keatimilwe, 2005). Formed in 2002 MIST, is relatively new; hence, the disadvantage in lacking an explicit research methodology which can be viewed, discussed and conducted by each of the ten researchers who are being sponsored (Section 4.1) – a lot of time had to be spend to choose a research method in this study, in the end a mixture of both qualitative and quantitative was used especially in the analysis of results. Notwithstanding, the research method used in this study had to be visible, and accessible to policy-makers and practitioners at MIST for them to be able to audit and to bring about confidence and deeper comprehension of the capability of these research methods.

MIST has also developed the National Innovation Capabilities Database (NICDB)¹ on RSTI resources and activities where new generated data from the researchers will be stored and used in implementation and planning of the Science and Technology Policy of Botswana (S&TP-B) which was approved in 1998 (Teng-Zeng, 2007). To this end, this research at Loughborough University (LU) is commissioned for a three year period (January 2008 – December 2010).

2.9 Summary

The model of the research process that is described in this chapter has the following six steps:

1. Identification of a Research Problem;
2. Choice of a Research Goal;
3. Choice and Framing of the Research Method;
4. Application of the Selected Research Method;
5. Decision on the Usefulness of the Results; and
6. Decision on whether the Research Problem has been Solved

The identified research problem is related to the gross national income (GNI) per capita. A research goal, which when attained solves the research problem, is related to the technology adoption lifecycle and the re-design strategies.

Three research methods are combined and applied to data to produce graphical results such as charts and dendograms. These research methods are framework analytical approach, cluster analysis and Kolb's model. The results are evaluated to check whether they provide useful information and to check whether the research problem has indeed been solved.

¹ A Summary of High Level Key results for the 2004-05 of the Research, Science and Technology (RST) Survey is available from the Department of Research, Science and Technology (DRST) which hosts the National Innovation Capabilities Database (NICDB).

Chapter 3: Literature Review

Introduction

At the start of this research programme, the researcher was not familiar with many of the structured product design methods available to industry and academia worldwide as published in literature. Initially, therefore, a wide range of literature was studied to gain a broad understanding of the product design field.

The content of this chapter is guided by the research justification (Section 1.2) and geared towards investigating the following four research areas (Section 1.3).

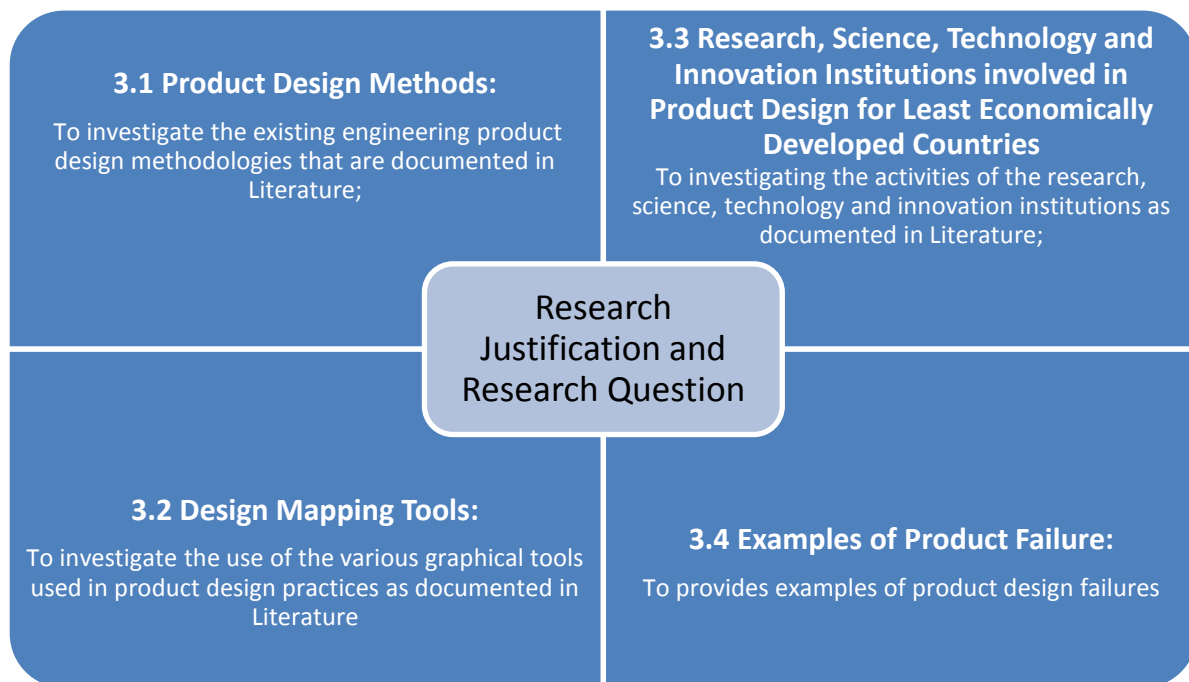

Figure 12: Chapter Overview

Figure 12 shows the overview of this chapter. Section 3.1 identifies the engineering product design methods that are documented in educational literature focusing on the types, categories, lifecycle mapping and graphical tools (i.e. designer's toolkit); Section 3.2 looks at the design mapping models used for information processing and communication; Section 3.3 discusses the establishment and operations of Research, Science, Technology and Innovation Institutions (RSTI); reason for, and examples of, product failures are discussed in Section 3.4 and a short summary is given in Section 3.5.

3.1 Product Design Methods

3.1.1 The Types of Product Design Methods

Norton (1996, p. 3) states that:

“the word design is from the Latin word designare meaning to designate, or mark out”

and that it “encompasses a wide range of meaning.” Hence, it is a term that is often qualified by other words to focus its meaning into a particular context; such an approach gives rise to the different types of design such as design process, design method, system design, engineering design and product design. This study reviews the following nine product design methods, listed according to the continent from where they are acknowledged to originate (Figure 5) and chosen with the assistance of citation metrics (Section 2.5):

1. North America
 - 1.1. Axiomatic Design;
 - 1.2. Stage Gate New Product Development;
2. Europe
 - 2.1. Total Design.
 - 2.2. Systematic Engineering Design Approach (otherwise known as Pahl and Beitz Method);
 - 2.3. Teoriya Resheniya Izobratatelskikh Zadatch (TRIZ);
3. Asia
 - 3.1. Quality Function Deployment (QFD);
 - 3.2. Taguchi Methods (otherwise known as Robust Design);
4. Reverse Engineering and Re-Design; and
5. Research for Development (R4D)

The above list shows that the use of structured product design methods may be widespread.

3.1.1.1 Axiomatic Design

Axiomatic design was pioneered and developed in an effort to address the lack of scientific basis in the practice of design; the premise for axiomatic design is that there are generalisable principles underlying the design process – these general principles “are fundamental truths that are always observed to be valid and for which there no counter-examples or exceptions” and are referred to as axioms; the approach of identifying and utilising axioms is key to axiomatic design (Suh, 1990; Naddeo, 2006).

According to Suh (1995), axiomatic design consists of:

1. Four domains which are comprised of a four vectors in each domain to represents design scheme through domain decomposition resulting in a hierarchies;
2. Mapping between these domains;
3. A process of zigzagging between the domains; and
4. The design axioms,

The four domains associated with axiomatic design may be schematically illustrated as follows (Figure 13):

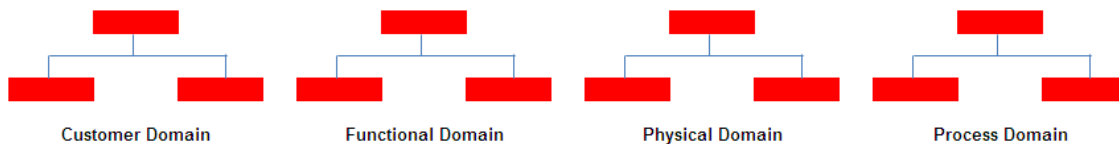

Figure 13: The Four Domains in Axiomatic Design

Each of these domains is comprised of following representative vectors (the word vector here is used to denote a column matrix representation):

- The customer domain is comprised of customer requirements or attributes (CA) representative vector which the customer is looking for in a product;
- The functional domain is comprised of functional requirements (FR) representative vector (sometimes referred to as engineering specifications) of the product together with any constraints;
- The physical domain is comprised of the design parameters (DP) representative vector which has been selected by the designer or design team to satisfy the FR; and
- The process domain is comprised of the process variables (PV) representative vector to physically manufacture the DP.

The process of breaking down the representative vectors of a domain is referred to as domain decomposition and results in a hierarchical tree diagram representation of the domain.

The sequence for implementing these domains during design is important and it controls the process of domain decomposition. For any pair of domains (Figure 13 and Figure 14), the one on the left represents what has to be achieved and the one on the right represents a proposal to achieve that which is required by the domain on the left. The link between any pair of domains is referred to as domain mapping and produces at each level in a hierarchy tree diagram representation of the domain i.e. the first level CA are mapped into first level FR which are mapped into first level DP which are mapped into first level PV. From there, the decomposition process breaks down the customer domain to yield second level CA and the mapping process continues to the other domains at the respective level. This hierarchical level by level decomposition and mapping is referred to as zig - zag. This hierarchical zig-zagging enhances early assessment of candidate design solutions to improve the efficiency of conceptual design by exposing functional structure (Gonzalves-Coelho, 2004).

$$\text{Gain} = \frac{\text{Products}}{\text{Societal Needs}} = \frac{\text{Creative Process}}{\text{Creative Process} \times \text{Analytical Process}} \cong \frac{1}{\text{Analytical Process}} \text{ for Analytical Process} \gg \text{Creative Process}$$

Equation 3: Gain for the Feedback Loop of Design

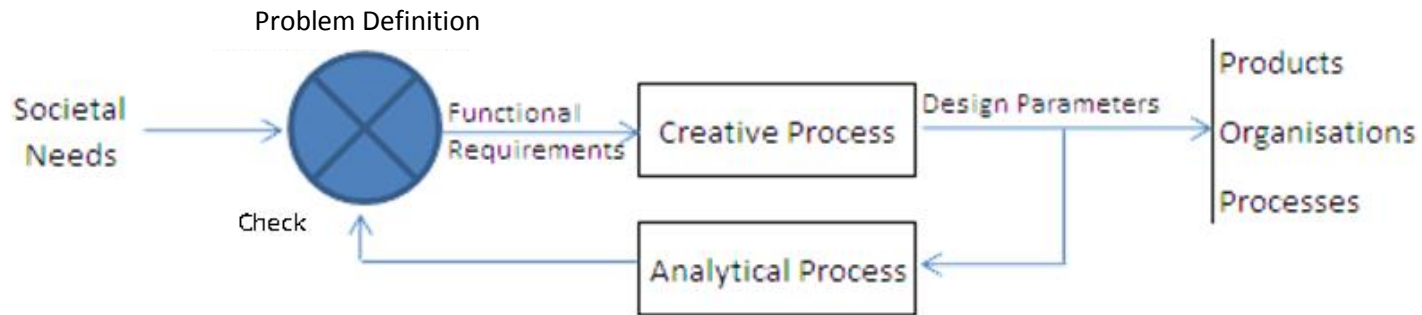
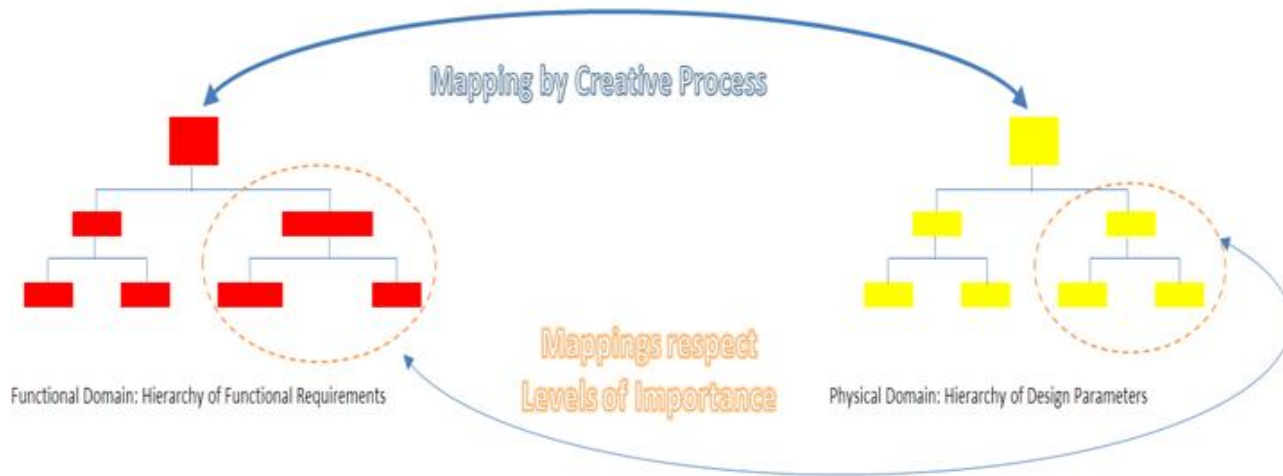

Figure 14: Mapping, Decomposition, Zig-Zagging in Axiomatic Design - Showing only the Functional Domain and the Physical Domain(Source: Adapted from Suh, 1990)

The mapping, which may be demonstrated with the aid of design mapping models (Section 3.2), between the domains could be represented by matrixes to shows the relationships between their contents (Ahn and Lee, 2006). Using the matrices, the general equation for the mappings could be:

$$\{\text{Left Domain}\} = [\text{Design Matrix}] \{\text{Right Domain}\}$$

The sets theory could also be used to shows the same information (Zeng, 2001).

Hierarchies would be used to correspond to the different levels of generality in the framework of domains; with the advantage of alleviation of complexities associated the design process and could benefit lean manufacturing processes (Houshmand and Jamshidnezhad, n.d.).

Suh (1990) stipulated that all these characteristic of axiomatic design should be executed within the following “four distinct aspects” of design (Figure 14):

1. Problem Definition;
2. Creative Process;
3. Analytical Process;
4. Ultimate Check

The above four aspects may be visualised as being organised as a feedback control loop. The essence of this is to show that the capability to analyse the quality of the creative process is paramount to design as would be demonstrated by the ‘gain’ of the feedback loop which can be approximated by Equation 3 (Figure 14).

Axiomatic Design could be combined with Design Structure Matrix to accommodate the iterative nature of the decomposition-integration process. (Guenov and Barker, 2004). Also, when combined with robust design, axiomatic design applies well to product modularization based on quality (Nepal et al, n.d.)

3.1.1.2 Stage Gate New Product Development

The stage-gate new product development method was developed to manage new product development and innovation processes (Cooper, 1990). According to O’Connor (1994), the standard stage gate new product development method consists of five stages intertwined between five gates although a different number of stages and gates may be used in different types of projects (Figure 15).

Each stage and gate is a group of activities which may be executed sequentially or in parallel and have the following characteristics:

1. A set of deliverables or input criteria that the preceeding stage must bring or pass;
2. A set of exit criteria upon which to judge the deliverables;

3. An output decision on an action plan to stop further work, recommend re-work or approve advancement to the next stage; and
4. The gates are manned by senior managers with a multi-disciplinary backgrounds and different functional control in the company.

Activities related to the new product are undertaken as a project with a selected project leader (Karlstrom and Runeson, 2005). The project leader is responsible for presenting progress at all gates.

In this sense, the stage-gate new product development method is similar to the success-failure measures model developed by Griffin and Page (1993) who found that managers were interested in success-failure measures at product level whereas academics emphasised measuring at organisational level.

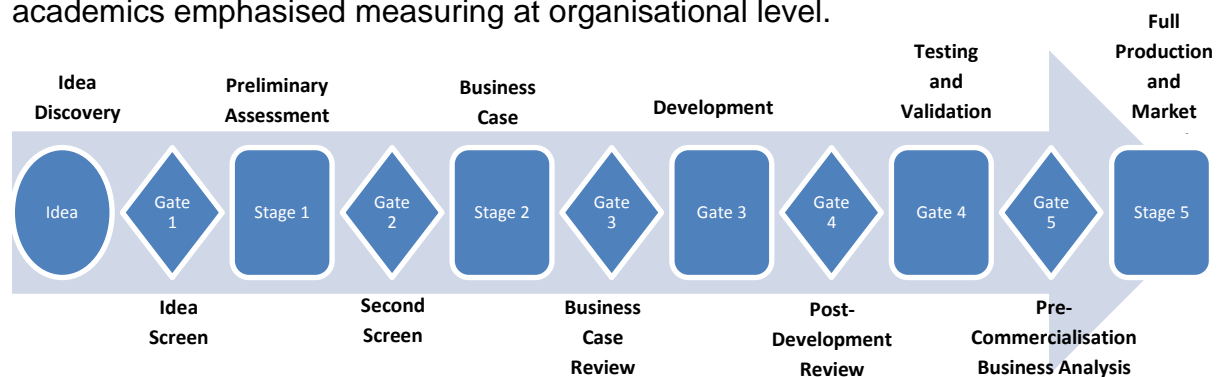

Figure 15: Stage-Gate System (Source: Adapted from Copper, 1990)

Subsequent to discovering a new idea, the activities in the five stages are synchronised as follows:

1. Preliminary Assessment Stage where a preliminary market and technical assessments are undertaken through quick product concept tests and appraisal of organisational capacity to develop and manufacture the product;
2. Business Case Stage which involves conducting detailed market research and financial analysis as well as technical and economic feasibility studies;
3. Development Stage which involves the creative generation, selection and manufacturing of product concept(s);
4. Testing and Validation Stage where the manufactured product concept(s) are evaluated in-house and in the field; and
5. Full Production and Market Launching Stage at which the market launch and operations plans are implemented.

3.1.1.3 Total Design

Total design methodology was pioneered by Stuart Pugh at Loughborough University, United Kingdom (Clausing and Andrade, 1996). A good design methodology is required

to minimize the rate of modifications due to rejection by customers and also for the reduction of high repetitive rates of technical analysis – prototyping – rejection cycles which cause poor customer satisfaction; Pugh (1991, p. vii) postulates that product design:

1. Is not a subject, but an activity that structures the incorporation of subjects such as mathematics and physics;
2. Is different from, and provides an integrated framework for, detailed analytical and technical topics such as machine element design, stress analysis and finite element analysis; and
3. Is, and should support other, technology-independent methods including management procedures.

The principles of total design comprise a design core that is universal to the practice of design and incorporating inputs from engineers and non-engineering professionals; these inputs, referred to as “partial design” must be coordinated or the product will fail in the market. To learn these inputs, courses are broken down into subjects manageable to both students and teaching staff. In the context of product design, the faculties of engineering educational institutions are concerned with imparting major portions of the engineering course as partial design whereas the professional departments of industry should be concerned with total design – regardless of the thoroughness of its application, misdirected partial design on its own is incomplete for product design.

The designer’s tool-kit is all techniques used by the product designer or product design team to operate the design core activity. There are two types of the designer’s tool-kit: technology-independent tool-kit and technology-dependent tool-kit.

- The technology-independent designer’s tool-kit consists of techniques which are directly related to the design core (Figure 16): competition and competition analysis; information acquisition and synthesis; concept selection and data handling; optimization and cost patterns; market trends.
- The technology-dependent tool-kit consists of techniques which are directly related to the technological knowledge (Figure 16): information analysis and mechanical stress analysis; control and electrical stress analysis; mechanisms and costing; hydraulics and electronics; Manufacturing Technology.

Pugh (1991, p. 5) states that total design is:

“an activity that encompasses product, process, people and organization”.

The design core of total design consists of the following six activities (Figure 16).

1. Market or User Needs;
2. Product Design Specification (PDS);

3. Conceptual Design;
4. Detail Design;
5. Manufacture; and
6. Sales

The design activity begins with an identified need which, when fulfilled, would lead to successes in an existing market place or create its own market. The product design specification controls and envelopes activities in the rest of the design core and is derived from the need (Figure 16); in other words, the main feed-forward design activity flow is from the need through the product design specification to sales. At all stages, the design activity flow is iterative enabling main activity flow to be reversed.

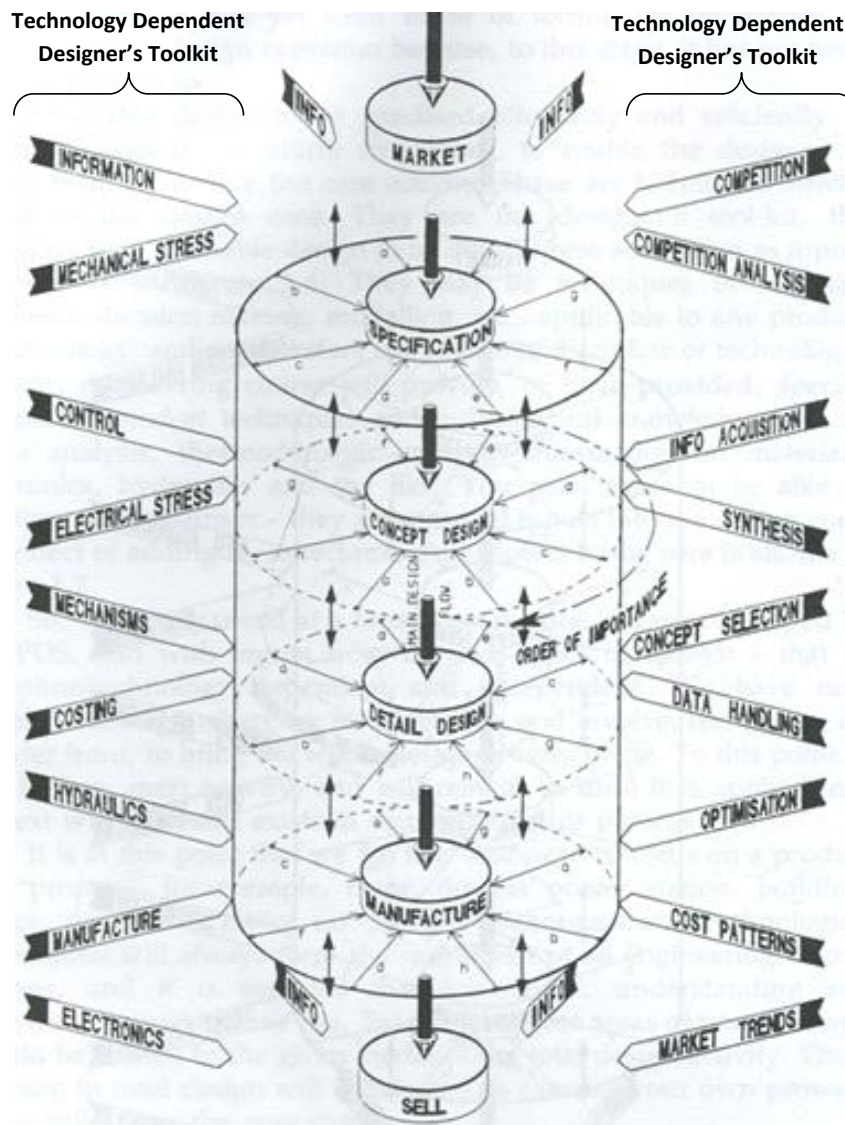

Figure 16: Total Design (Source: Pugh, 1991)

Beside lack of rigour in executing a design core activity, iterations are caused by changed circumstances affecting the design core thereby leading to the evolution of the product design specification (Figure 17).

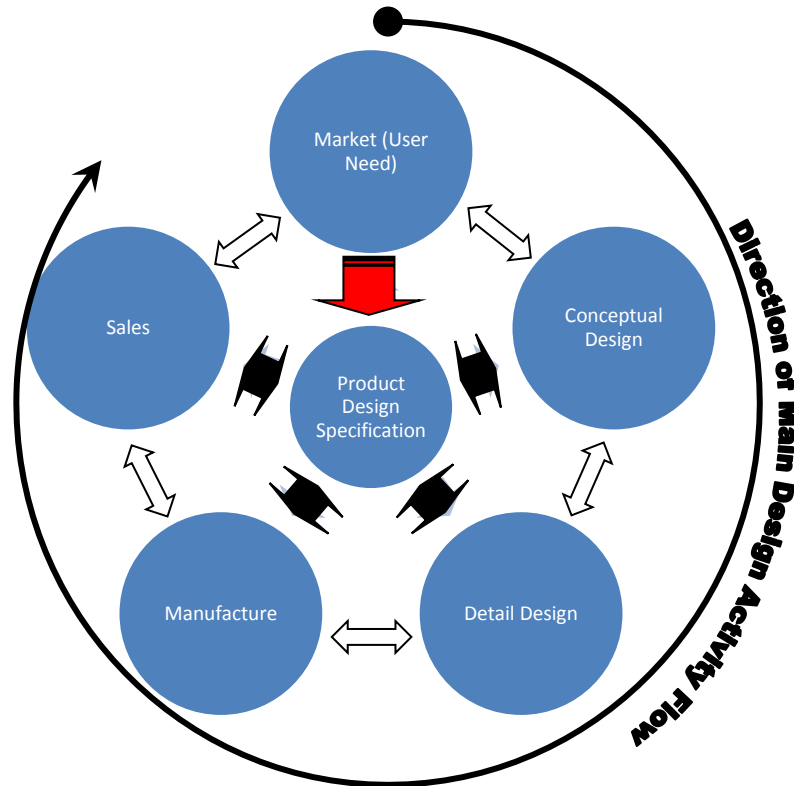

Figure 17: Total Design (the dark arrows show the elements of the product design specification and the white arrows show iterations)

3.1.1.4 Systematic Engineering Design Approach (also known as Pahl and Beitz Method)

Systematic engineering design optimises objectives within partly conflicting constraints; both these objectives and constraints change with time therefore solutions must be optimised with respect to time (Pahl and Beitz, 1996).; to this end, Ahmed (1998) reinforces the role played by changes in culture and innovative environments.

However, the boundaries of engineering design might still be fuzzy (Horvath, 2004). Dixon (1966) and Penny (1970) as cited in Pahl and Beitz (1996) put (the role of) engineering design at the centre of two intersecting cultural and technical streams (Figure 18). Engineering product design “enables effective communication within and without the immediate design sphere” since the design activity can be performed either singly or in a team (Pugh, 1991, p. viii). Suh (1990) agrees that the design activity profoundly affects all product development stages that follow; therefore it is paramount to be aware or to investigate the boundaries of engineering design.

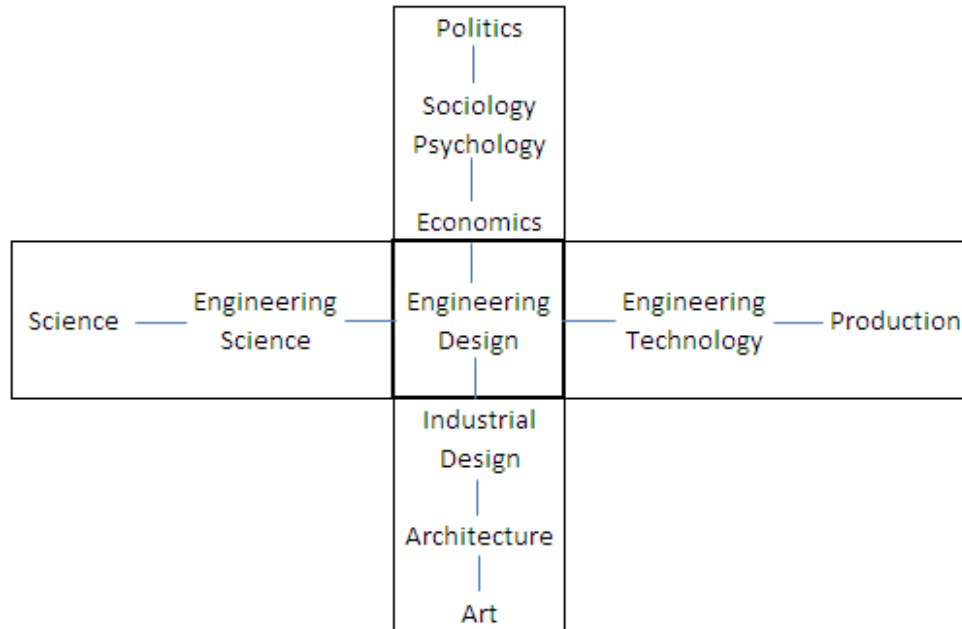

Figure 18: Engineering Design as a central activity between Cultural and Technical Streams (Source: Pahl and Beitz, 1996)

According to Pahl and Beitz (1996, p. 10), a design methodology must:

- Direct problem solving;
- Promote Inventiveness;
- Have compatibility with other disciplines;
- Add to its understanding and modernisation of product design through education and industrial learning;
- Support proactive solution finding; and
- Facilitate the application of known solutions.

Systematic engineering design can be divided into four main phases (Figure 19):

1. Planning and Task Clarification i.e. Specification of Information;
2. Conceptual Design i.e. Specification of Engineering Principles;
3. Embodiment Design i.e. Specification of Layout; and
4. Detail Design i.e. Specification of Production.

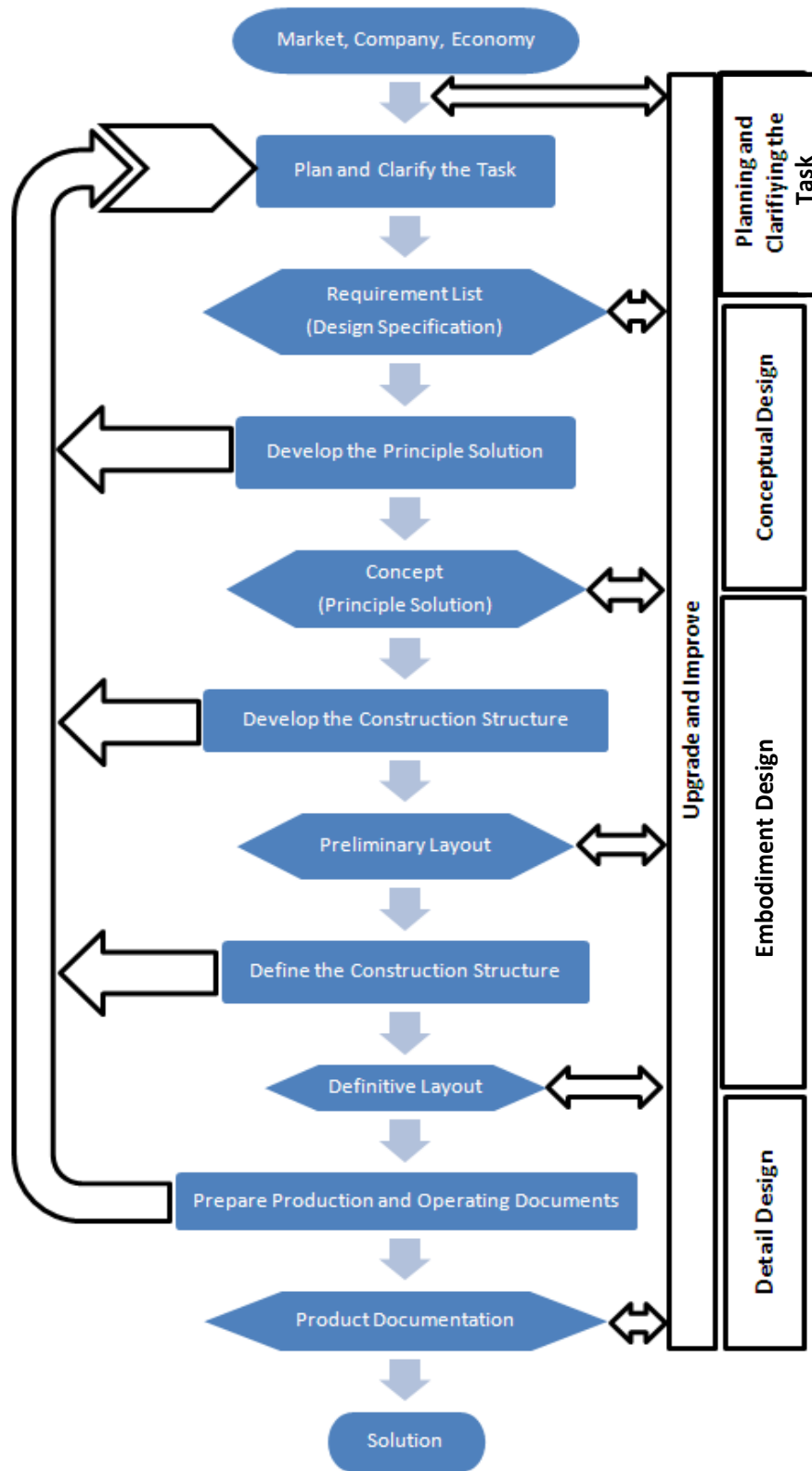

Figure 19: Systematic Engineering Design Approach (Source: Pahl and Beitz, 1996)

3.1.1.5 Teoriya Resheniya Izobratatelskikh Zadatch (TRIZ)

TRIZ is Russian acronym for Teoriya Resheniya Izobratatelskikh Zadatch; the equivalent acronym in English is TIPS for Theory of Inventive Problem Solving. TRIZ originated from extensive studies of technical and patent information (Yang and Zhang, 2000). The basis of TRIZ is the discovery that patterns exist in patent claims, many of them based on the same working principles (Terniko, 1997). Thousands of patents have been studied and classified into five categories:

1. Routine Designs
 - a. Basic Parametric Advancement
 - b. Change or Re-Arrangement of the Design Configuration
2. Inventive Solutions
 - a. Identifying conflicts and solving them with known physical principles
 - b. Identifying new principles
 - c. Identifying new product functions and solving them with known or new physical principles

Based on these categories, key observations were made which include:

1. Evolution of engineering systems (products included) develop according to the same patterns, independent of engineering discipline or product domain – these patterns may be used to predict trends of future evolution in a product domain;
2. Conflicts are the key drivers for product inventions; the principles for eliminating these conflicts are universal across product domains;

The TRIZ Tool-kit uses the TRIZ contradiction matrix which are used in conjunction with the descriptions of the engineering design parameters (Table 7) and engineering design principles (Table 8). TRIZ has the following structure (Figure 20):

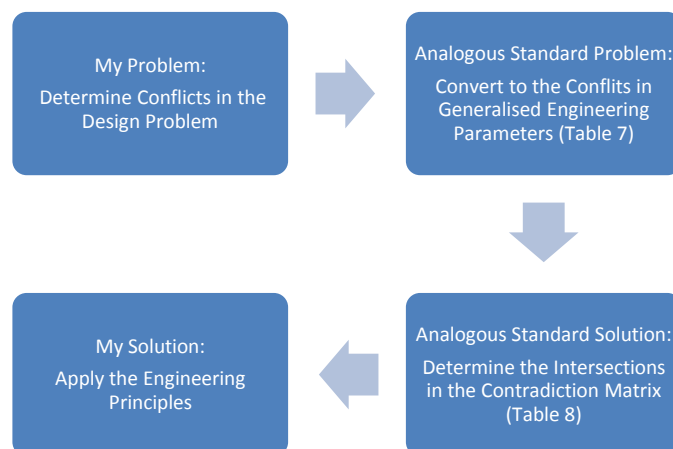

Figure 20: TRIZ (Source: Ideation International Manual, 1996 cited in Terniko 1997)

1	Weight of Moving Object	2	Weight of Stationary Object
3	Length of Moving Object	4	Length of Stationary Object
5	Area of Moving Object	6	Area of Stationary Object
7	Volume of Moving Object	8	Volume of Stationary Object
9	Velocity	10	Force
11	Stress or Pressure	12	Shape
13	Stability of Object Composition	14	Strength
15	Duration of Action Generalised by Moving Object	16	Duration of Action Generalised by Stationary Object
17	Temperature	18	Brightness
19	Energy Consumed by Moving Object	20	Energy Consumed by Stationary Object
21	Power	22	Energy Loss
23	Substance Loss	24	Information Loss
25	Waste of Time	26	Quantity of a Substance
27	Reliability	28	Accuracy of Measurement
29	Manufacturing Precision	30	Harmful Actions affecting the Design Object
31	Harmful Actions generated by the Design Object	32	Manufacturability
33	User Friendliness	34	Repairability
35	Flexibility	36	Complexity of Design Object
37	Difficulty to Control	38	Level of Automation
39	Productivity		

Table 7: Generalised Engineering Parameters for Describing Product Metrics

Design Principles		Design Principles	
1	Segmentation	21	Rushing Through
2	Removal (Extraction)	22	Turn Harm into Good
3	Local Quality	23	Introduce or Change Existing Feedback
4	Asymmetry	24	Go-Between
5	Joining (Combining)	25	Self-Service
6	Universality	26	Copying
7	Nesting	27	Cheap Short Life instead of Expensive Longevity
8	Counterweight	28	Replacement of a Mechanical Pattern
9	Preliminary Counteraction	29	Use Pneumatic or Hydraulic Solutions
10	Preliminary Action	30	Use Flexible or Fine Membranes
11	Advanced Cushion (Protection)	31	Use Porous Materials
12	Equipotentiality	32	Use Colour
13	Inversion (Opposite Solution)	33	Homogeneity
14	Spheroidality	34	Discard or ReGenerate Parts
15	Dynamism	35	Change Aggregates State of Object
16	Partial or Overdone (Excessive) Action	36	Use Phase Changes
17	Moving into a New Dimension	37	Application of Thermal Expansion
18	Mechanical Vibrations	38	Use Strong Oxidation Agents
19	Periodic Action	39	Use Inert or Vacuum Atmosphere
20	Uninterrupted Useful Effect (Continuity of Useful Action)	40	Use Composite Materials

Table 8: Engineering Design Principles

According to Domb and Kling (2000) the growth of TRIZ would depend on its easiness and successful use by beginners. Generally, students could show enthusiasm in applying TRIZ tools and methods combined with the morphological matrix and declare to feel comfortable in using both methods in a combined way: the morphological matrix seems to help them to organize the conceptual design tasks while TRIZ methods and tools would help them to gain a deeper insight in the problematic and to gain confidence in the proposed solutions (Leon-Rovira, 2002).

TRIZ could be used to innovate design for disassembly (Justel et. al, 2006). Care should be observed not to solely use TRIZ in product development, as it does not have tools to understand and learn from consumers (Pelt and Hey, 2006); although TRIZ could improve design and market research for consumer products (Hipple, 2006). A framework could be developed for set-based concurrent engineering (SBCE), pioneered by Toyota, using TRIZ for products intended for the global market (Bhushan, 2007).

3.1.1.6 Quality Function Deployment (QFD)

Quality function deployment (QFD) refers to the functions responsible for quality in all departments of a company. Quality function deployment was developed to identify and improve functions that affect quality in the product development process (Akao, 1990). QFD is fruitful where a distinction must be made between an analytical approach and a design approach:

- Analytical Approach: This is the examination of customer complaints regarding their use of existing products and then move upstream towards the design staged searching and correcting the factors that contribute to these complaints – this approach is mainly associated with quality control.
- Design Approach: This is the examination of customer demands, expressed explicitly or latent, regarding their intended use of new products – quality function deployment is one of the methodologies associated with this approach.

Quality function deployment starts with capturing the actual and implied demands of the customer and translating them into quality assurance targets for the entire product development process, incorporating design reviews that ensure the quality of the product from the design stage. According to Bouchereau and Rowlands (2000), quality function deployment has four phases (Figure 21):

1. Product Planning: House of Quality (Figure 22);
2. Product Design: Parts Deployment;
3. Process Planning; and
4. Process Control: Quality Control Charts.

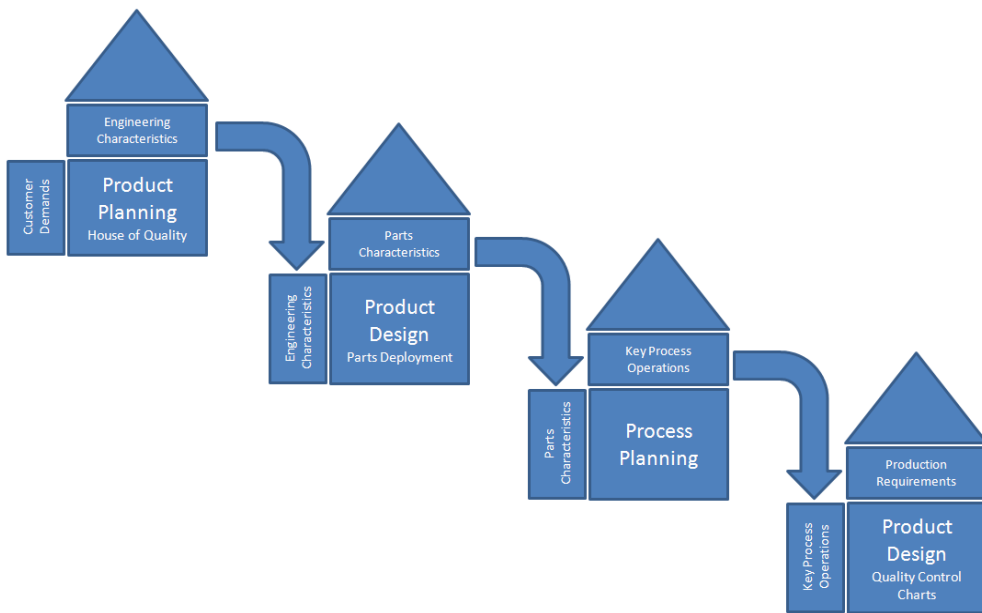

Figure 21: Quality Function Deployment

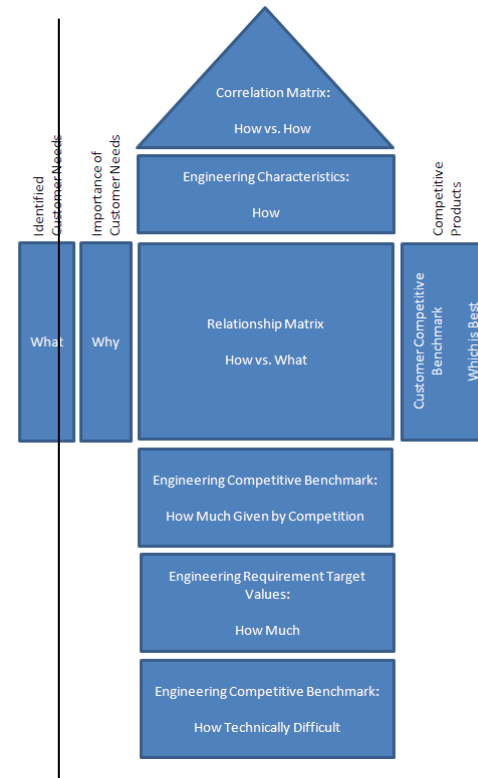

Figure 22: House of Quality

3.1.1.7 Taguchi Methods (also known as Robust Design)

Robust Design could be defined as the selection of a solution, through selection of configuration parameters, that would perform according to specification regardless of variations in the problem e.g. material, implementers e.t.c. Taguchi's principle of robust product design is believed to be trying to adjust the design of the product so that it is insensitive to the effects of uncontrolled variation (Gaury and Kleinjnen, 1998).

Robust design or Taguchi method introduced a different method to measuring quality in product design – it introduced the loss function as a specification i.e. as a performance metric, to measure of quality. The loss function establishes a financial measure of user dissatisfaction with a product's performance, measured statistically, as it deviates from a target value.

A product can be designed for operation at static product application for performance that is fixed at one level or dynamic product application which allows for a design that is pitched at today's customer demands but can be adjusted by changing the product's sensitivity to future customer requirements. The intended product output is called a signal factor; sources of variation cause deviation in product's performance: uncontrollable sources of variation are called noise factors; adjustment factors change the sensitivity of a product to these noise factors – the aim of robust design is a product that is least responsive to noise factors.

According to Ross (1996) and Otto and Wood (2001), robust design could be divided into four phases (Figure 23):

1. System Design: This is design at the customer need capturing and conceptual stage;
2. Parameter Design: This stage considers changes to the nominal product configuration that are easily accommodated. The product is represented by the parameter diagram which shows all the adjustment, noise and signal factors as well as the response;
3. Tolerance Design: This is design intertwined with manufacture process specifically to ensure that passes the necessary tolerance levels; and
4. Two-Step Optimization: A control factor is a parameter of a product that can be manipulated to define the set points as desired by the customer.

The four phases could be summarized into six tasks: Identification of design variables, noise variables and turning variables and setting target ranges for them; formulation of the design of experiment (DOE) by varying the design variables according to an inner orthogonal array with noise variables varied according to another outer orthogonal array (a study referred to as crossed array); for each combination of design factors compute the S/N ratios, where $S/N = -10 \log [\text{mean square deviation of the objective function}]$ (Whitfield et. al., 1998); an analysis of variance (ANOVA) would be perform using S/N ratios as response to identify design

variables with a significant effect on S/N, which would be set at levels that maximize S/N; a second ANOVA would be performed using the performance measure(s) averaged over the noise combinations, as response to identify design factors with significant effects on performance measure(s) which could be adjusted to improve performance.; the procedure is repeated again until performance is satisfactory. Yet biological systems could give product designers hints about how to incorporate principles of robustness into our engineering practice (Sussman, 2007).

Once a prototype (virtual or physical) has been constructed, a test to obtain the mean response and compare with the target response. The variation of the response is reduced by adjusting the features of the product; followed by similar adjustments for the mean. The features of the product must be experimentally tuned first as they are costly to alter after adjustment have been made for the mean; hence the term two-step optimization.

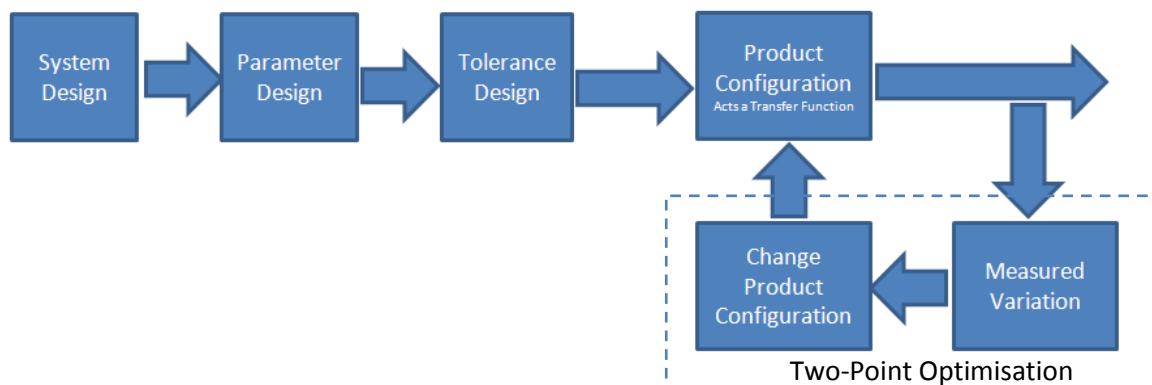

Figure 23: Robust Design (Taguchi Method)

Taguchi’s method may be extended to solutions which involve necessity variables (with ranges of values all of which must be satisfied), and those which involve possibility (with range of values any of which might be used) (Otto and Antonsson, 1991). However, when robust design is used under uncertainty and design optimization using computer experiments are combined, the “optimal” robust design solution may not be as robust as it ought to be, because of the effects of meta-model interpolation uncertainty (Apley et al, 2006).

3.1.1.8 Reverse Engineering and Re-Design

Reverse engineering is examination process that involves extracting artefacts and synthesizing abstractions that are less implementation-dependent; it does not involve changing or replicating the artefact (Chikofsky and Cross, 1990). The reverse engineering and re-design method requires the designers to “start with a product in the market place and a vision to re-design it for some perceived market defect or envisioned evolution” (Otto and Wood, 2001) – this is literally the ‘reverse’ of the conventional engineering product design method. Structuring the product design process has benefits in education and industry (Otto and Wood, 2001):

- Structured design process is mandatory for industry to effectively decide what projects to bring to market, schedule the development steps within a competitive market and create a robust, delightful product (Pahl and Beitz, 1996); and
- Structured product process is beneficial for education because concrete hands-on product experiences, applications of contemporary technologies, successful applications of applied mathematics and scientific principles, studies of systematic experimentations, exploration of boundaries of product design methodologies and decision making for real product development.

Reverse engineering and re-design is associated with an experience-hypothesis-understanding-execution learning cycle (Otto and Wood, 2001). The sequence of activities must be determined after the investigation stage among the following (Figure 24): Waterfall or Serial Flow, Concurrent or Parallel Flow, Spiral Flow, Vee Flow and Hybrid between these.

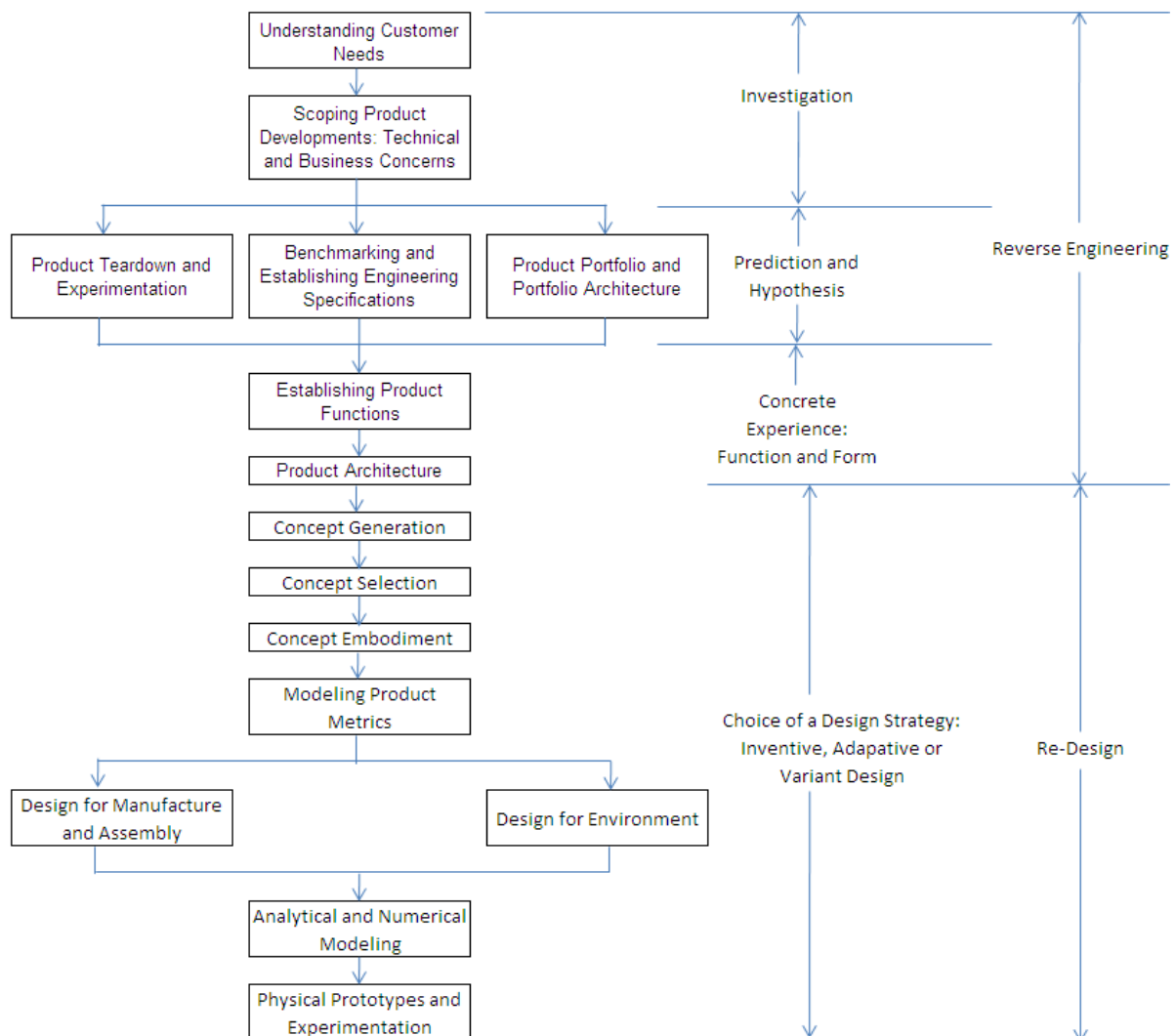

Figure 24: Reverse Engineering and Re-Design showing a Hybrid Waterfall-Concurrent Lifecycle (Source: Adapted from Otto and Wood, 2001)

3.1.1.9 Research for Development (R4D)

The IDRC utilised the programme – focused research for development approach to design sorghum milling products and is described in a case study by Schmidt (1987). The research-for-development method has been used by the International Development Research Centre (IDRC) in Sub-Saharan African countries including Botswana, Burkina Faso, Gambia, Ghana, Lesotho, Malawi, Mali, Niger, Nigeria, Senegal, Sudan, Tanzania, Uganda, Zambia and Zimbabwe as well as India and Bangladesh. The core activities for the research-for-development are identification of a problem or opportunity, establishing selection criteria for potential solutions, generation of a technology (through either adoption, adaptation or invention), verification of the solution and bringing the technology into wide spread use.

Like Total Design (Section 3.1.3), each core activity in any of the research-for-development approaches is grouping of techniques. For example, the needs assessment core activity is comprised of techniques, which are comparable to the market/user needs in Total Design; these techniques may be categorized according to the divergent approach, convergent approach, need-specific approach, function-specific approach and form-specific approach (Table 11).

Technique	Categorisation	
	Divergent – Convergent	Need – Function – Form
Recognition of a Problem	Convergent	Need
Characteristics of the Problem	Divergent	Need
Definition of Beneficiaries	Divergent	Function
Sustainability Issues Aspects	Divergent	Function
Organisational Strategy Check	Divergent	Form
Establishment of Agenda	Divergent	Form
Data Collection Planning	Convergent	Form
SWOT Analysis	Divergent	Form

Table 9: Needs Assessment Techniques of the Research-for-Development Method (Source: Adapted from Schmidt 1987 and Laws et. al, 2003)

Just like the market or user needs, the following layout results if each of these techniques may be represented by a matrix then be put together in an affinity diagram (Figure 25):

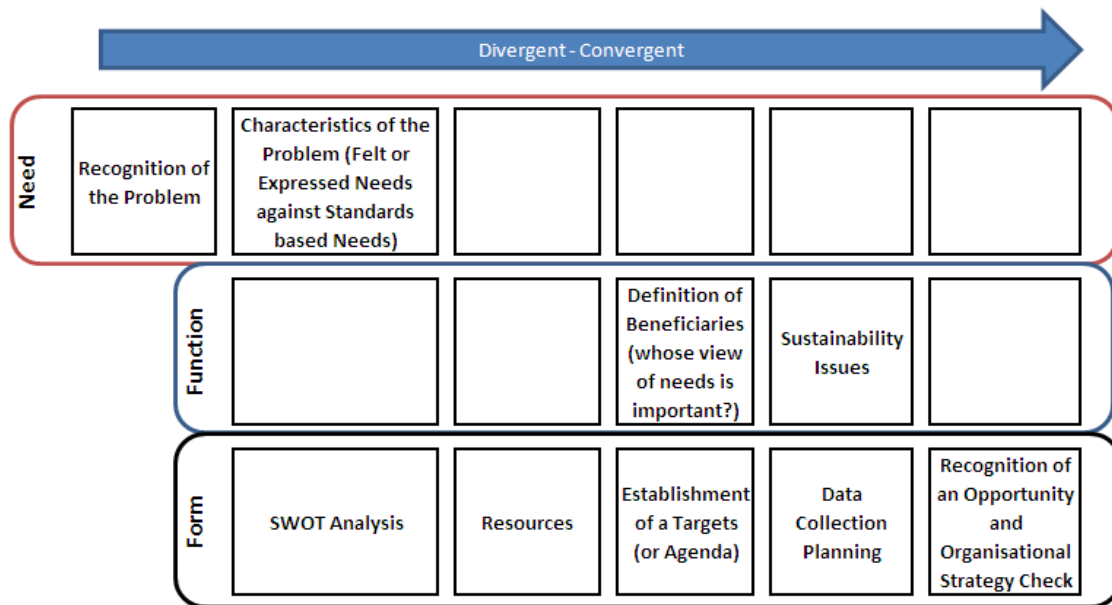

Figure 25: Needs Assessment Techniques of the R4D Method

This shows that the product design methods practiced in industry may also have similar characteristics to those presented and taught in educational institutions in (Section 5.3.2).

3.2 Design Mapping Models

Design models are communication tools that are used to document descriptions and are mainly comprised of diagrams and mathematical expressions. The development of these tools should follow a need-function-form structure; this should ensure that the link between the needs and the solutions would be explicit and offer traceability. The development of the design models should evolve from the most important section identified within the model; specifications should be developed and evolve with the models to provide a quantitative criterion with units of measure and (a range of) target values. Specifications should be used to try and anticipate possible areas of failure and specify design targets to avoid that failure by limiting the range of acceptable solutions (Cross, 1994; Baxter, 2002).

Design models should be developed through brainstorming sessions supplemented by mind mapping techniques and sketching methods such as 6-3-5, where a brainstorming team would be restricted to six members; each member should come up with models of three concepts complete with elementary sketches and a brief description. The three concept models should then be passed to other members within the six-member team who should be at liberty to generate other ideas or modify those from other members. This process would be repeated until all six members get their original model documents back; it should then be repeated five times.

From information in the models, a morphological analysis could be performed for needs with the means of achieving the needs, sub-functions with the means of achieving the sub-functions, e.t.c. During morphological analysis, electrical, chemical and mechanical engineering sub-systems could be separated for individual attention. The fundamental logic functions for electrical sub-systems are encoding, storage, counting, comparison, arithmetic and decoding; the design of chemical plant could be based on six unit operations of reactor feed preparation, reactor, separator feed preparation, separator, recycle, and environmental control; and for mechanical engineering, the standard components include shafts, keys, springs, gears, bearings, screws, clutches and brakes. These are explicitly well known and they form the basic building blocks that are commonly available in the market to all digital systems (as integrated circuits or programmable logic devices), chemical plants (e.g. the separation processes include cyclones, filters and centrifuges).

The 'set' structure could be a principle of evaluation exercises associated with design models. This set would be the most general object that can be evaluated and nothing outside of it; for instance, the evaluation exercise should not be used to generate concepts. This should be a rule in any evaluation. The criteria form another set i.e. a collection of only those criterion to be used in the evaluation exercise. The criteria should be weighted on a numerical scale to be used for ranking models. The rankings should be summarized for each model and the models ordered according to their summaries. This would give an ordinal ranking i.e. a relative comparison between the concepts. The ordinal ranking is used as an indicator and not as a selection method. Models that have large overall summaries should be scrutinized on the few low scores for improvement. In order to select the best concept, a unit of measure should be assigned to every criterion. A unit of measure is more like probability of certainty measure with the un-preferred model as the datum and the preferred concept per criteria representing 100% compliance with criterion. Other models are proportionately given values from 0% to 100%. The units of measure should be normalized to enable summation of the criteria for each concept. Normalization could be done by multiplying it by the maximum allowed effect and then dividing by the difference between the lowest score and the highest. In addition, each criterion in the set of criteria should be compared with others to give an importance value. A set of normalized units of measure would result. It would be necessary to attach risk levels or uncertainties in decision as the concepts are ranked for each criterion by giving the values tolerances. An analysis of the selection error might then be performed. At the end of this any evaluations, a review could be held (Blanchard and Fabrycky, 2006). Depending on the information available a decision must be made as to whether a mathematical model, as opposed to physical prototype, is adequate.

3.2.1 Activity Diagram

The activities followed by users would detail the functional implementation and an activity diagram (AD), a flowchart that shows the flow of activities, should be drawn.

AD could affect the direction of the design process. The qualitative information of the flows of matter, energy and signals (and their units of measure) associated with each user should be established.

3.2.2 Tree Diagrams

An ‘attack tree’ could be used to replicate the work of an adversary to find the weak points in a system with its parent node as the component (objective, access, risk tolerance, motive) that prompted the analysis; the child nodes would be life cycle of the component and each phase in the life cycle breaks down into vulnerability leaves – which are pruned using countermeasures (Salter et al, 1998).

3.2.3 Input-Output Concept Diagram

The driving decision should be the choice of whether the whole process would operate in a continuous or batch mode based on required flexibility and throughput (Coulson and Richardson, 1993; Turton et. al, 2003). An input-output concept diagram (IOCD) would be drawn with the inputs on the left and the outputs (i.e. the products and by-products) on the right. These inputs and outputs should be categorized as matter, energy or signal and be defined only at the boundary of the diagram. All transformations taking place should be written in the body of the IOCD or the overall function would be stated in verb-noun form. Figure 26 shows the IOCD for oxidation of propane. Depending on the perspective, the chemical equation could be replaced by phrase describing the process, a mathematical expression of energy, Boolean expression of digital bits e.t.c.

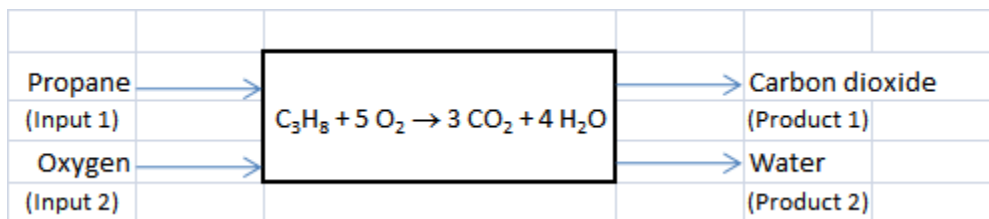

Figure 26: Process Input-Output Concept Diagram

3.2.4 Block Flow Diagram

The sub-functions necessary to execute the overall process should be identified in a process of functional analysis. Functional analysis would explain the alternatives transformation of inputs to outputs by means of graphical illustrations and mathematical expressions (North Star INCOSE Chapter Meeting, 2008). Blocks should be put in the body of IOCD to represent the sub-functions resulting in a block flow diagram (BFD) that would be comprised of a series of interconnected blocks with connections showing inputs and outputs. Although they are many, five graphical representations are normally used depending on the amount of information to show (Long, 2002). These are Function Flow Block Diagram, N² Chart, Integrated Definition Diagram, Data Flow Diagram and Behaviour Diagram. The behaviour

diagram would be executable in that it contains a balance of both control constructs and data triggering. Sometimes timelines are used to identify time critical sub-functions (National Aeronautics and Space Administration, 1995). Figure 27 shows a block flow diagram for a digital controller.

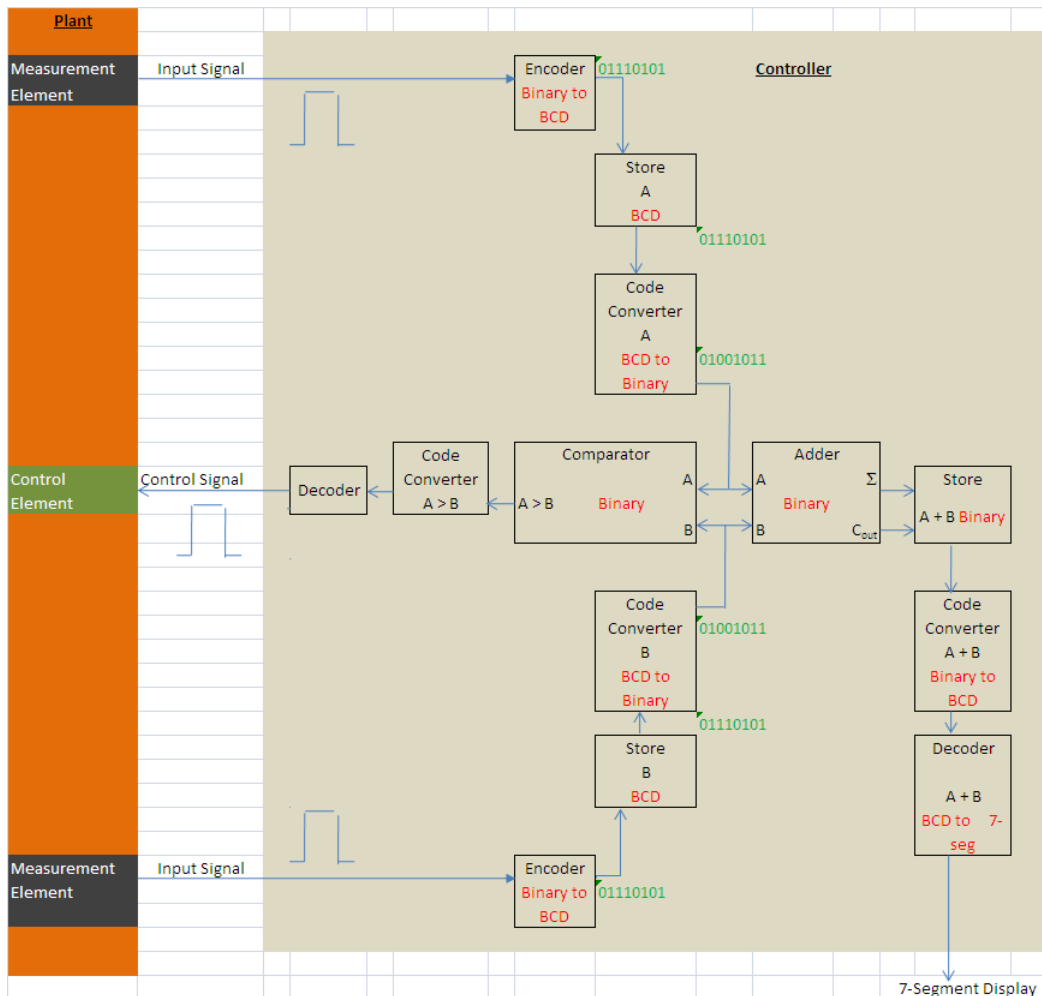

Figure 27: Block Diagram showing Binary Information and Bit Codes

There could be several BFDs to demonstrate different alternatives to produce the outputs and these must be identified and evaluated. An order of magnitude estimates, of the triple constraints (of time, cost and performance) and risk assessment, should used as the main basis criterion, as well as process safety. In particular, order of magnitude cost estimates could be made from complete cost of previous similar solutions adjusted for capacity and inflation (Coulson and Richardson, 1993; Turton et. al, 2003).). The ratio of the capacities would be raised to some exponent and multiplied to the original cost (Equation 4).

$$\frac{C_{t_{estimate}}}{C_{t_{previous}}} = \left(\frac{A_{estimate}}{A_{previous}} \right)^n$$

Equation 4: Order of Magnitude Cost Estimate

Where Ct = Cost, A = Capacity and n = exponent.

For chemical processing, the value of the index for most equipment is often approximately 0.6. A BFD is sometimes referred to as a function structure diagram (FSD) should be enhanced into by including more information and could use symbols in accordance with standards such as ASME ASA Y32.11, ANSI/IEEE 91-1984 e.t.c. The BFD should obey physical laws. A legend should be produced for the equipment. Material, energy and signal flows could be indicated using information flags such as numbers (enclosed in a circle or rhombus) on their flow-lines directly on the BFD with its directions shown by arrowheads. The numbers should be used to index to tabulated conditions of the flows. The table for conditions of material and energy flow should be developed through material and energy balance calculations.

3.2.5 Configuration Sketches

Innovations could come about as a result of changing components or relationships between the components in a product (Henderson and Clark, 1990). Table 9 shows how such innovations could be applicable to BFDs. By following a dominant flow of input as it is sequentially acted upon by sub-functions and branching as necessary, sub-assemblies could be identified and used to assign design teams and relationship between sub-assemblies could be called architecture.

Sub-Function	New	Modular	Radical
	Old	Incremental	Architectural
		Old	New

Sub-Function Relationship

Table 10: Innovative Movements

The types of architectures include:

1. Integral architecture where the sub-assemblies are made from a single or very small number of entities i.e. the entire BFD is mapped into a single entity.
2. Modular architecture where the sub-assemblies perform a group of the sub-functions. Open architecture, where the sub-assemblies are attached by flow linkages instead of other sub-assemblies, is preferred since it simplifies detachments.

Configuration sketches (CS) could be drawn to show the layout of sub-assemblies and taking into account the input-output interfaces in the BFD. Based on the CS, scope estimates could be made that takes into account the cost of sub-function equipment; the more accurate is the sizing of the equipment, the more accurate this estimate. Order of magnitude cost estimates should be done for each piece of equipment in the FSD while indices could be used to make inflationary update e.g.

the Chemical Engineering Plant Cost Index (CEPCI) (Coulson and Richardson, 1993; Turton et. al, 2003). The Lang Factor method could also be used and a comparison made with the estimate from order of magnitude estimate (Equation 5):

$$C_{estimate} = F_l \sum_{i=1}^n C_i$$

Equation 5: Lang Factor Method

Where F_l is the Lang Factor, C_i is the cost of major pieces of equipment in the PFD and n the number of major pieces of equipment. Plants processing fluids have a Lang Factor of 4.74, those processing solids have a Lang Factor of 3.1 and plants processing both solids and fluids have a Lang Factor of 3.63. Estimates of the operating costs should also be done and the process checked for profitability.

3.2.6 Technical Drawings

The CS could be detailed using design guidelines, standards, and mathematical models using appropriate parameter choices that give optimum performance. Inherent at this stage might be the development of models that represent the concept and predict its performance under varied inputs flows. The technical drawings (TD) could be developed from choices of materials using specific parameters and the CS of the selected concept. TDs would enable detailed estimate of the triple constraints and risk assessment of the solution to be made and profitability analysis should be updated. An area of concern would be the transmission of information from the design office to a manufacturing workshop. A company involved in a computer aided draughting (CAD) should lay down company standards for the drawing structure (Davis, 1983).

3.3 Research, Science, Technology and Innovation Institutions involved in Product Design for the Least Economically Developed Countries

Criscuolo and Palmade (2008) studied how and why only a few least economically developed countries (LDC) have been successful in getting out of abject poverty in a period of one generation. They found that the successful LDC initially relied on a small, dedicated team of experts (Figure 30):

1. That had experience in various fields including engineering;
2. That had access to influential top level government offices;
3. That has responsibility and accountability for a large development budget; and
4. Pushed a reform agenda spanning a wide-ranging and profound microeconomic reforms covering many national policy areas and industries with a focus on:
 - a. Import substitution, developing export-driven industries and identifying key constraints;

- b. Export oriented business zones such as for light manufacturing;
- c. Engaging the private sector;
- d. Corporate citizenship;
- e. Lead deliberate efforts to create public sponsored institutions; and
- f. Provided a link between international donor agencies and governments.

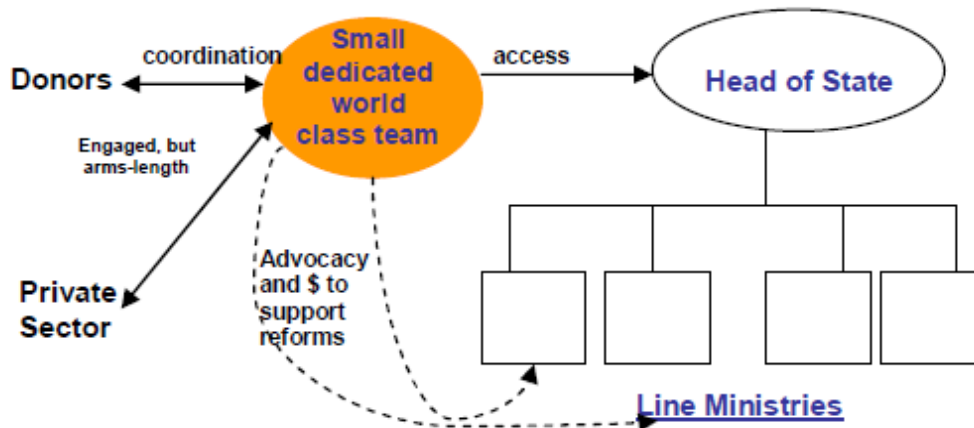

Figure 28: How Successful Least Economically Developed Countries Started (Source: Criscuolo and Palmade, 2008)

The activities of the public sponsored institutions created under the arrangement that involves reform teams are generally referred to using words such as research. Some international donor agencies such as International Development Research Centre (IDRC) and Department for International Development (DFID) tend to call their activities related to product design as research for development (R4D). In agreement, Laws et. al. (2003) notes that many kinds of activities commonly classified as research are accomplished as part of development work and they are of two types:

1. Programme - focused Research for Development; and
2. Issue - focused Research for Development.

Programme-focused research for development relates to programmes as outputs from policies whilst issue-focused research for development addresses concerns that are beyond any programme; the latter is normally intended to influence the policy itself and participatory research may fit in the intersection between the two (Figure 31).

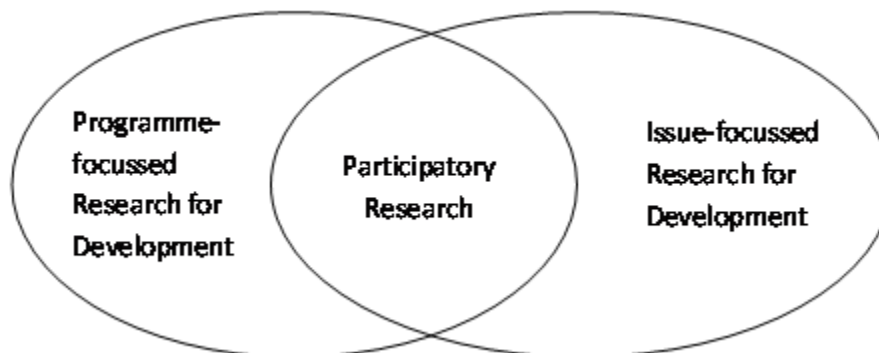

Figure 29: Types of Approaches to Product Design (Source: Adapted from Laws et. al, 2003)

3.3.1 Programme - focused Research for Development

Programme-focused Research for Development consists of the following seven activities:

1. Needs Assessment;
2. Community Profiling;
3. Stakeholder Analysis;
4. Action Research;
5. Programme Evaluation
6. Participatory Research; and
7. Participatory Learning and Action (PLA)

3.3.2 Issue - focused Research for Development

Issue - focused Research for Development consists of the following five activities:

1. Research required for campaigning;
2. Thematic research to learn from the experience of other countries;
3. Review of known facts on the issues under consideration;;
4. Ensuring that the decision makers understand the views of the less powerful people; and
5. Reframing the issues

3.4 Examples of Failed Products

Suh (1990, p. 3) notes the outstanding engineering design failures that occurred in both the DCs: Chernobyl nuclear power accident in the Soviet Union that spread radioactive elements over Europe; the fatal explosion of the NASA Space Shuttle due to O-ring failure over the United States of America; and in the LDCs, the disastrous engineering design failures include the Bhopal Union Carbide plant in India which killed over 2 000 people. All these accidents occurred in the mid-1980s.

A well documented example of a product that failed in MDCs, with no fatalities, is the Sinclair C5 hybrid electric three wheel car for use as personal transport the British market (Brown and Allport, 2010); as a product the car failed because there was no market research.

A well documented example of a product failure in LDCs, with no fatalities, is the animal drawn wheel tool-carriers which were “rejected because of their high cost, heavy weight, lack of manoeuvrability, inconvenience in operation, complications of adjustment and difficulty in changing modes” (Starkey, 1988). The Wheeled tool-carriers were developed by French and British institutions such as the British National Institute of Agricultural Engineers (NIAE) and International Crops Research Institute for the Semi-Arid Tropics (ICRISAT).

Some wheeled tool-carriers were designed in India with large scale production in Brazil, Honduras, Nicaragua and Mexico as multi-purpose products used for ploughing, planting, weeding and transport in countries such as Angola, Botswana, Cameroon, Ethiopia, Lesotho, Malawi, Mali, Niger, Nigeria, The Gambia, Senegal, Somalia, Uganda, Zambia and Zimbabwe.

The wheeled tool-carrier was “successful” even under theoretical economic models given the farm size and use patterns, yet it was never adopted by farmers; negative response by farmers was apparent from the 1960s yet by 1986 work tool carriers by institutions, aid agencies and national programmes was still continuing – highlighting problems of technology transfer practices that emphasize technical proficiency over suitability for the needs of the farmer.

These examples indicate the dependence of product design on people, organizational structures, technical and functional processes of the product itself. The literature-based product design guidelines are presented to purposefully start on the soft issues i.e. the effects required by the users and the effort required from the designer.

3.5 Summary

The following eight product design methods have been studied: Axiomatic Design; Stage Gate New Product Development; Total Design; Systematic Engineering Design Approach (otherwise known as Pahl and Beitz Method); **Teoriya Resheniya Izobratatelskikh Zadatch** (TRIZ); Quality Function Deployment (QFD); Taguchi Methods (otherwise known as Robust Design); and Reverse Engineering and Re-Design.

It was discovered that the product design methods which are documented in literature are structured in two ways: the divergent – convergent structure and the need – function – form structure.

Chapter 4: Analysis of Design Methodologies

4.1 Introduction

The qualitative research survey selected for this study mixed aspects from the framework method, cluster analysis and Kolb's model (Section 4.3; Figure 30). In accordance with the research programme (Figure 5), product design methodologies that are documented in literature were first identified and used to originate important themes which are summarised in this study using standard data collection instruments (Section 4.2). Based on these themes, a (literature-based) proposal of product design guidelines was developed (Section 4.4.1) which was then authenticated for structural integrity against existing product design methods used in industry (Section 4.4.2); Section 4.4.3 looks at the structure of product design methods. Section 4.5 provides a discussion of the findings whilst Section 4.6 provides a summary.

Design methodologies published in the literature are many and varied and are currently used in a piecemeal manner by design teams around the world with no strategy or framework available to assist design teams in using a range of methodologies in a coordinated or coherent way.

This chapter provides an analysis of current design methodologies and introduces the basis for product design guidelines (PDG) within a new Conceptual Framework as a means of integrating a number of existing methods. The detailed development of the PDG and conceptual framework is discussed in Chapter 5. It is intended that these will assist design teams in Botswana to help alleviate the main problems outlined in Section 1.1 but may also be a valuable approach in the MEDC as well.

The sample frame for this research was three RSTI in Botswana, a least economically developed country (LEDC) and a sport product design company that is incubated by Loughborough University in Great Britain, a most economically developed country (MEDC). These allowed for the credible strengthening of the proposed engineering product design guidelines and provided answers to the research questions particularly the recommendation of a product design methodology suitable for the LEDC. The proposed product design guidelines are comprised of a conceptual framework, product design notation and configuration scheme (Chapter 5).

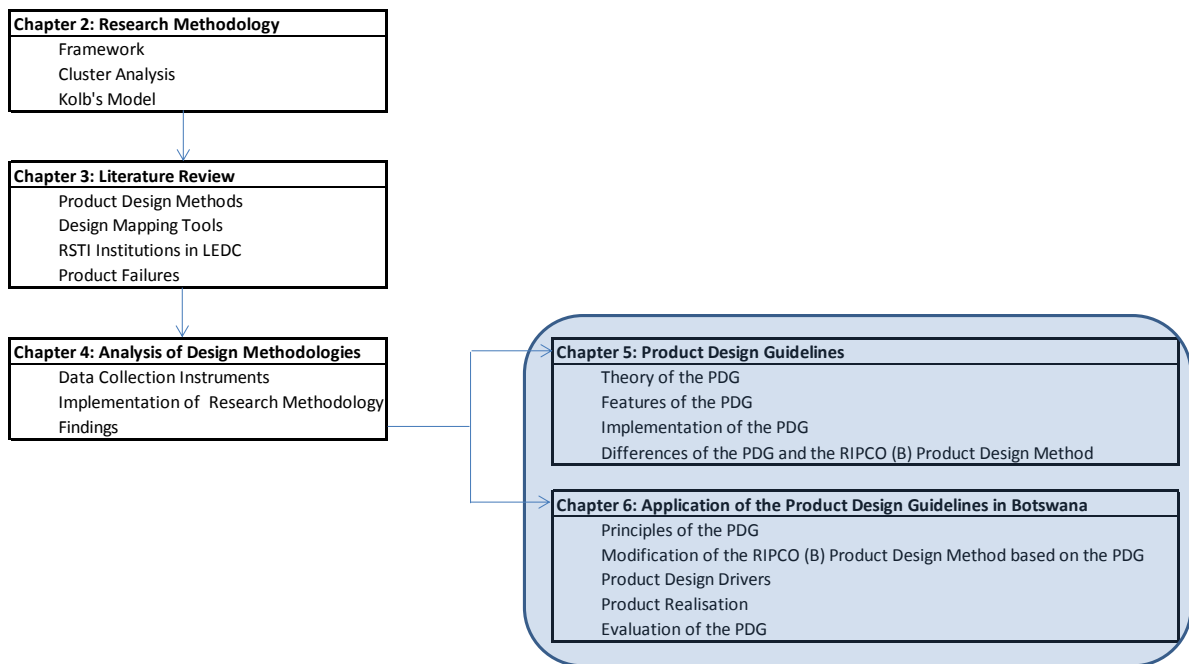

Figure 30: Highlight of the Industry Surveys and Case Examples

4.2 Overview of Data Collection Methods

A combination of the following standard instruments for data collection was used in this study:

- ❖ Observations
- ❖ Questionnaire – for the development of the industry-based product design guidelines proposal:
 - e-mail / Self Completion
 - Unstructured Interviews
 - Pilot
 - Face to Face
 - Telephone
- ❖ Secondary Data – for the development of the literature-based product design guidelines proposal:
 - Textbooks
 - Professional Codes of Conduct
 - Documented Company Procedures
 - Internet

The Botswana National Science and Technology Policy (BNSTP) and the Science and Technology Policy for Botswana support the empowering of national innovation organisations that design, develop, adapt and apply technology (Botswana Technology Centre, 1998; Ntshole, 2000; Keatimilwe, 2005). An internet search was deployed to find organizations which may contribute to the practice of product design towards the requirements of these above mentioned policies. Eleven organisations were identified in Botswana (Appendix 1). Secondary data was collected from these organisations and four key variables were established: research mandate preferably as stated in the mission statement, the industry served by the organization i.e. the nature of products being designed by the organisations, product design method used by the organizations and the technologies acquired by the organizations which are useful for product design such as 3D CAD Modelling Software. The main aim of the internet search is to assess national capacity to design products, software, hardware and service that address these two national policies. Coincidentally, this study was also undertaken at the beginning of the National Development Plan 10 (Botswana Government, 2009).

Based on the secondary data, the organisations may be categorized according to their mandate i.e. academic research institutions comprised of the University of Botswana (UB) and the Botswana College of Agriculture (BCA); research, science, technology and innovation institutions (RSTI) made up of Botswana Technology Centre (BOTECH), Botswana Vaccine Institute (BVI), Department of Agricultural Research (DAR), National Food Technology Research Centre (NFTRC), Rural Industries Promotions Company (RIPC(B)); and non-government organizations

(NGO) which are the Permaculture Trust of Botswana (PTB), Thusano Lefatsheng and Veld Products Research and Development (VPR&D).

Based on the key variables from the internet search, a questionnaire was planned to get an outline for a description of the design process(es) used at these organizations by flowcharting high-level design tasks with a word description from a sample of RSTI in Botswana and the United Kingdom. A pilot structured interview was conducted in Loughborough University, United Kingdom, at the Department of Technology and the Wolfson School of Mechanical and Manufacturing Engineering (Appendix 2 and 3). Although, the questionnaire used in the pilot structured interviews was useful, it was modified for clarity and eventual use in Botswana (Appendix 4).

In order to gather exploratory data, study trips were undertaken to Botswana to make observations on technologies used by some of these organizations. With the exception of the NGO, all of these organisations have a range of hardware and software used directly for product design activities which vary considerably in terms of complexity, expense and useful support to the design activity. The most elaborate industrial mechanical workshop which is also equipped with CNC cutting, milling and turning machinery was observed at RIPCO (B) and NFTRC houses the most top class industrial analytical equipment. The only rapid prototyping equipment was a 3D printer observed at UB. DAR does not have a demarcated product design office and has no 3D CAD modelling software but it gives technical advice on the design and selection of agricultural machinery. Additional documents such as annual reports and product brochures were requested from the librarians at BOTEC and RIPCO (B). A visit was made to the VPR&D but initial discussions with the research assistant indicated a general lack of activities due to no donor support; this situation also affected PTB and Thusano Lefatsheng. These NGOs have at different times in the past made customer inquiries which eventually lead to the development of products; for example, the development of the wild melon seed extractor at RIPCO (B) to make cooking oil; and NFTRC works in close collaboration with these NGOs on processing indigenous foods such as traditional beverages. Therefore one would be interested in the structure of the input they make at the beginning of the design process; this study is also interested to develop a suitable structure where none exists.

The NGOs are mainly involved with extension work using appropriate technology which they out source. NFTRC is involved with food process design and BVI is mandated to develop veterinary vaccines. Only BOTEC and RIPCO (B) were established specifically to design and develop equipment but they sometimes collaborate with BCA, DAR and UB.

Based on these observations, the questionnaire was administered by e-mail to BOTEC, RIPCO (B), NFTRC and Progressive Sports Ltd (Appendices 5 and 6). An unstructured face to face interview was held with a lecturer of Bachelor of Design in Industrial Design at UB using the questionnaire as a guide; an electronic copy of the

syllabus was availed to the researcher. At BOTEK the questionnaire was answered by the Renewable Energy Engineer; at RIPCO (B) by the Chief Engineer – Technology Transfer; and by the Process Engineer at NFTRC. Additional clarifications on the answers to the questionnaire were sought through telephone discussions and more information was requested by e-mail from human resource officers in the three organizations. It would not have been beneficial to issue a lot of questionnaires per organizations because the researcher was directed to a representative design engineer since the design method is universal within the organization – in the case of RIPCO (B), the engineers are audited to work according to its ISO 9000: 2000 Quality System Documentation (Quality Office, 2008); hence, an experienced design engineer was selected to answer the questionnaire.

4.3 Aspects of the Qualitative Research Methodology which were Used in this Study

Qualitative research may be used to answer four types of questions: contextual, diagnostic, evaluative and strategic questions. Cluster analysis can also be used to create research questions (Romesburg, 1984). First a data matrix is collected, and then cluster-analysed to obtain a tree diagram which is then examined to spark research questions. However, in this study the framework analytical qualitative approach (Section 4.3.1) was used to create two hypotheses which were then tested using cluster analysis (Section 4.3.2) and validated using Kolb's model (Section 4.3.3).

4.3.1 Framework

Framework is an analytic approach developed in the context of applied qualitative research (Hubberman and Miles, 2002). The framework approach has five distinct but highly interconnected key stages:

1. Familiarisation
2. Identifying a Thematic Framework
3. Indexing
4. Charting
5. Mapping and Interpretation

The familiarisation stage involves reviewing and gaining an overview of the body of material gathered (Figure 31). In this study, the familiarisation study involved studying product design methods documented in literature; the familiarisation stage also involved examining the answered questionnaires (Appendix 1) including observational and research notes. The questionnaire was also used as a topic guide for unstructured interviews especially at the pilot stage and the questionnaires were followed up for close to a year in which data on industrial case applications.

Four practical study trips were made to Botswana. In March 2008, the first trip was undertaken to make observations and gather exploratory data. BOTEK and RIPCO (B) were identified as the two main institutions where product design activities were

practiced on an industrial scale. The two institutions had strategic memorandum of understanding with several other organisations such as UB and DAR. Process design was identified as a potential area of interest for this study at NFTRC. The second and third trips, undertaken in January – June 2009 and September 2010, concentrated on validating the proposed product design guidelines at RIPCO (B). During the fourth practical trip, some prototypes were manufactured. Because the sample of organisations in Botswana is very small, qualitative research is more suitable for this study to gather an in-depth understanding of, and the reasons for, the behaviour of designers. This study would produce information only on the particular cases studied in the sample frame, and any more general conclusions are only hypotheses; this is a characteristic of qualitative methods. Quantitative methods can be used to verify these hypotheses; in this study, cluster analysis and Kolb’s model are combined to assist in this regard.

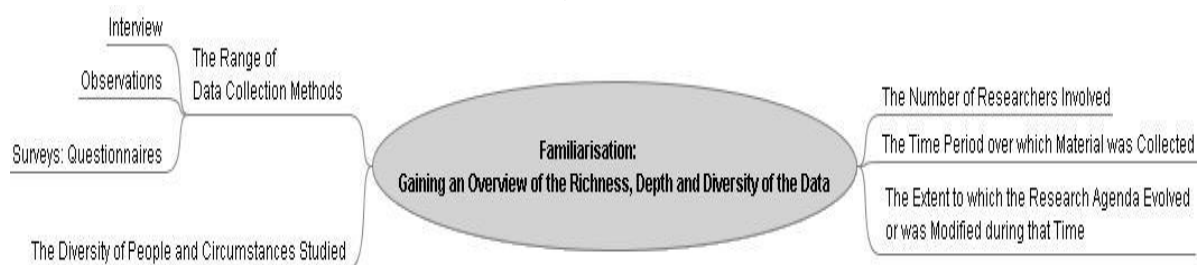

Figure 31: Familiarisation Stage

The thematic framework, the second stage, is developed from key issues, concepts and themes identified from the data being reviewed in a process of abstraction and conceptualisation. The thematic framework was influenced by three types of themes or issues: a-priori issues were introduced by the research questions and the questionnaire which was used as a topic guide, emergent issues raised by secondary data sources and questionnaire respondents themselves, and analytical themes arising from some patterning identified in the responses, attitudes, views or experiences such as repetitions. Different authors and respondents to the questionnaire use different words to refer to techniques applied in product design; this fact was an emerging theme that later caused the transformation of the group of techniques referred to as design activities as into three attributes (Figure 32).

The analytical themes stood out especially during industrial case applications at RIPCO (B); for example, the customer enquiry on the sorghum milling plant in Mochudi was attended using knowledge gained from the design, installation, commissioning and maintaining the sorghum milling plant in Pitsane – this squarely puts the product design drivers at the forefront of product realisation especially in products with higher capital intensity.

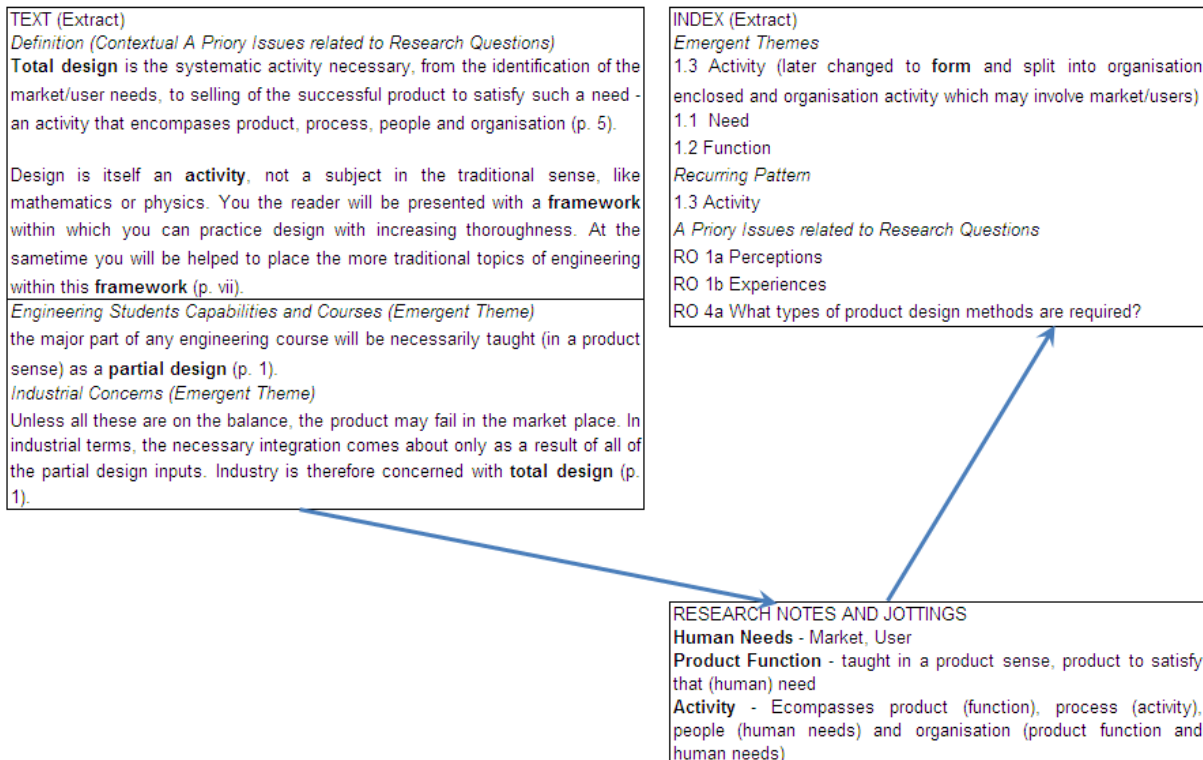

Figure 32: Development of the Product Design Process Thematic Index. Note that the bolded words are a-priory issues related to the research objectives (Source: based on Pugh, 1991)

The thematic framework was first used to index a few research notes from literature, observational notes gathered during the case applications and then applied to answered questionnaires which were appended to request more information from the respondents (Figure 33).

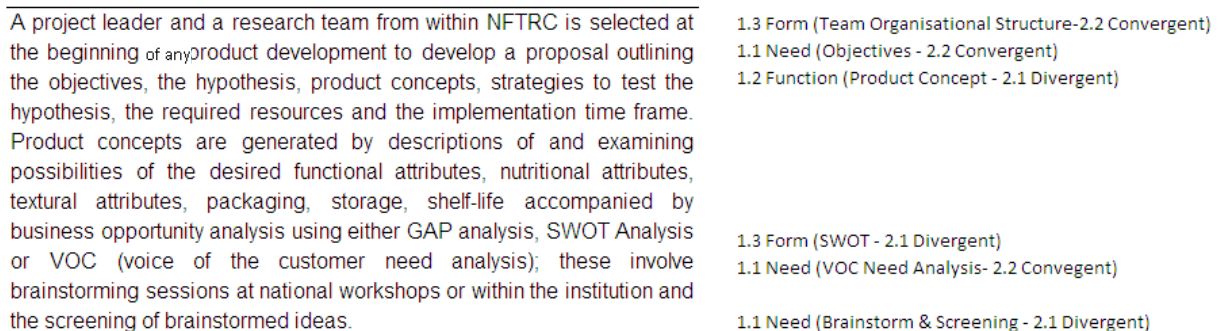

Figure 33: Indexed Transcript

The data was then removed from its original context and rearranged according to headings and sub-headings derived from the thematic framework to form charts (Figure 34). Observational notes from interviews with engineers were charted according to thematic analysis: where data was removed from notes of each respondent and charted across each theme. Questionnaires and secondary data were charted according to case analysis: where data is removed from questionnaires and secondary data with respect to a particular design methodology and applied across all themes. It was impossible to do case analysis on observational notes

because these were taken while the product design activities were being implemented; all products designed were at different stages of the design process and there were limitations on the time available so as to follow any project from inception to completion. For example, both the maize dryer and the agricultural planter were being designed by one design engineer during the second trip: the maize dryer was undergoing trials following prototype manufacture in the period January – March 2009; work on the agricultural planter started but with a schedule duration far more than the remaining period of the second trip.

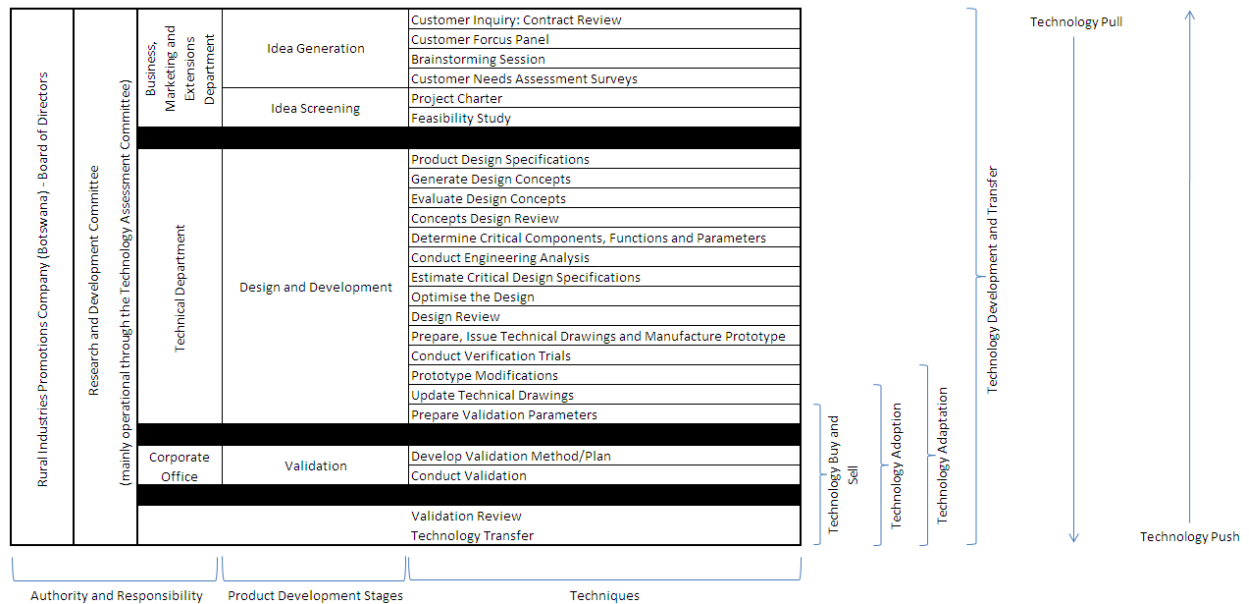

Figure 34: Case Analysis Chart showing the Definition and Types of Product Design at RIPCO(B) [adapted from ISO 9000: 2000 Quality System Documentation Manual for RIPCO(B)]

As mentioned before, the researcher was referred to a more experienced product design engineer because the method used per company was assumed to be uniform; this was confirmed by checking on project files at RIPCO (B) – an ISO 9000 certified organisation employing a common documented product design method and therefore all products had the same documentation.

Because of the limited time, observational notes and telephonic follow up were the only available options. Nonetheless, the charting stage is not a simple ‘cutting of blocks of text that are pasted to regroup according to index reference’ approach, but an abstraction and synthesis process that involves examining and extracting the essence of the notes best done early on after the practical trip and in some cases involved a follow up with the respondent – this is one area which sets the framework approach so different from other qualitative analysis methods. The five stages of the framework approach rely on the creative and conceptual ability of the researcher or the analyst to determine importance, prominence and connections. The analysis of the data was simplified by the fact that only one researcher was involved. The stages are interconnected and rework is possible and easy because the analytical process has been documented and is therefore accessible, even for supervision. In this

study, the framework approach is coupled with case examples to validate the research results.

The charting stage is followed by the mapping and interpretation of the data set as a whole and addresses the research questions. The mapping and interpretation stage helped to map the product design method as a creative process comprised of two stages: product design drivers as knowledge assets which include understanding customer needs, and product realisation which translate the knowledge assets into physical products; furthermore, the mapping and interpretation stage assisted in the:

- Detection of techniques that form part of the designer's toolkit. Essentially, a lot of equivalent techniques used in product design are given different 'names' in both literature and industry, but typologies could be used to distinctly show the pattern of similarities in the attributes and specific rules associated with a particular technique (Figure 35, Figure 43 and Figure 44);
- Definitions of a lot of notions and words in normal use during design – the definitions mainly explain and describe the thought process of the researcher and are an important part of the proposed product design guidelines (Section 4.3.2);
- Categorising and creating typologies. The typology of the emergent and analytical themes combine into a single graph which is another major component of the proposed product design guidelines;
- Identifying new ways of innovatively improving engineering product design; and
- Exploring similarities between literature and industrial product design methods.

4.3.2 Cluster Analysis

Cluster analysis is a generic name for a variety of mathematical methods used to estimate similarities (Romesburg, 1984). Mathematical methods used in cluster analysis deal with descriptions of data; the described data in cluster analysis are referred to as objects. Objects with similar descriptions are mathematically gathered into the same cluster. In this study, objects are the management and engineering techniques that make the designer's toolkit and cluster analysis is used to test the hypotheses developed using the framework qualitative approach (Section 4.3.1). The key critical steps for using cluster analysis for this purpose are the validation of the hypotheses test and framing of the hypotheses test.

4.3.2.1 Validation of the Hypotheses Test

Cluster analysis is used to address the following hypotheses which resulted from the framework analytical qualitative approach:

Hypothesis H₁: Product design methods creatively utilise a common set of rules or principles to interchangeably manipulate specific subsets of the attributes (Table 11).

Rule Number	Rule or Principles
1	Establish and acquire knowledge of the true user needs (including views, buying habits, legislation, statutory regulations, intellectual property and official opinions) of the Customer relevant to the product area normally through structured customer interviews and customer questionnaires to ultimately produce a coherent statement of the question.
2	Market Gap Identification (Cross plots (for identification) of relationships and patterns between parameters which specify the purpose, design goals, functional requirements and functional transformations of various features of the product obtainable from desk research sources such as reports, proceedings, reference books and catalogues) to ultimately produce a coherent statement of the requirements to be met by a product/solution being designed
3	The range of quantities within a product, human resources able to undertake activities and communications structure required to meet the market gap
4	The graphical representation, or otherwise, of interrelationship between product performance variables, (the rate of diffusion of a technology through) market segments, geographic concentration of interconnected companies, businesses, suppliers, educational and other associated institutions in the product field and the human resource workflows of stepwise activities and action in a manner that supports same time action and iterations.
5	The graphical representation, or otherwise, of visual descriptions to display the perceptions, mental position, image or identity of the product in customers or potential customers and to control economic demand and avoid recession through assigning responsibilities and general tasks to resources (human or otherwise) emanating from SWOT analysis with respect to the product.
6	Market Trend Analysis and Competitive Analysis (Determination of profiles of product features within the context of application of science, engineering and management principles, laws and equations to the development of material, energy and information consuming devices). The change of product features profiles are over time period is examined with respect to customer need change over the same period.
7	Objectives and constraints specified as target value (range), (engineering) metrics and parameters trade-offs (e.g. A set of mathematic inequalities - linear programming, materials). The product design specification is comprised of all techniques utilising design principles or rules 1 to 7.
8	Synthesis and Evaluation of Solutions (Combinations and putting together or building up of distinct physical prototype technologies into a connected whole and to select the optimum to meet the product design specifications i.e. the entire set of requirements contained in techniques over principles or rules 1 to 7). Any physical embodiment from principles or rules 1 - 8 is a manufactured prototype.
9	Production Strategy concerned with tested (analytical and physical) prototypes which are now products able to give the required quality demanded by the market/users e.g. the choice of whether to manufacture as large one-off, batch or mass production.
10	A qualitative and quantitative account of planned consumption or utilisation of any resources towards better product performance, customer satisfaction and direct delivery to the customer needs.
11	The planning of short term and long term expected or prediction of the future product characteristics and the specific technology solutions to meet them that have not yet been observed or realised including product entities that promise value to the customer as well as descriptions of user operation.
12	Identifying areas of concern in detail design and development of production capacity, field support capability and quality for parallel execution of concerned areas

Table 11: Rules or Principles used in the Designer's Toolkit

Hypothesis H₂: the basic structure of the product design methods uses a common set of attributes defined by the need-function-form structure (Table 12); and

Need	The effect envisioned to be required by the customer in the present or at a future time - concentrating exclusively on the human needs in the absence of the product
Function	The purpose to be performed by the product being designed to satisfy the envisioned customer need - concentrating exclusively on the absence of human interaction i.e. what the product can do on its own
Form	Tactical: Physical manifestation, Software and Service from the human-product interaction - concentrating exclusively on resources (human or otherwise) that satisfy the needs of an organisation
	Strategic: Physical manifestation, Software and Service of the human-product interaction - concentrating exclusively on resources (human or otherwise) that satisfy the future needs of a market

Table 12: Total Design Techniques

Answers to these two hypotheses would address the following strategic qualitative research question RO 4e (Figure 35): What and how new techniques could be developed to expand the designer’s toolkit and thereby identify new engineering product design methods? – although no new techniques were developed for several reasons including the time limitation of this research. To validate these hypotheses using cluster analysis involves the following three steps:

1. These hypotheses are used to predict the form that a classification tree (Figure 36) obtained with cluster analysis (using SPSS v18) of engineering and management techniques that make the designer’s toolkit of a known product design method, in this case, the total design method which utilises all four attributes and eleven rules (Table 13). Figure 35, which shows typography of Figure 36, builds on the structure shown in Figure 27.
 - a. The digit “1” as used in the SPSS v18 software follows the lifecycles as required by the PDG. The “Vee” lifecycle becomes more visible for convergent techniques as depicted by the digit “1”;
 - b. It would be noticed from Figure 36 that some techniques such as machine design (formulae) and physical domain appear to use different rules between Total Design Method and Axiomatic Design. Total Design lumps these under the umbrella term of detail design, axiomatic design separates them. The PDG recommends the establishment of the engineering principles so that they are used for instance to develop models through dimensional analysis in preparation of the product design specification;
2. This predicted tree would then be compared to an actual tree obtained with cluster analysis of most product design methods (including total design) documented in literature (Section 4.4.1) and practiced in industry (Section 4.4.2); and
3. Confirm or disprove the hypotheses depending on whether the predicted classification tree agrees with the actual classification tree.

Product Design Method	Primary or 1 st Term	Secondary or 2 nd Term	Tertiary or 3 rd Term	Design Rule	Need	Function	Form-Tactical	Form-Strategic
	Umbrella Term	Techniques	Attributes					
Total Design	Market/User Needs and Demands (Design Brief)	VOC Needs Analysis	Customer Needs	1	1			
		Legislation and Patent Search	Statutory Laws	1	1			1
		Parametric Analysis	Product Parameters	2	1			
		Product Features	Physical Product Components	2		1		
		Design Professionals	Human and Non-Human Resources	3			1	
		Design Professionals Activity	Action Items and Workflows	4				1
		Partial Design Contributions	Responsibilities and General Tasks	5				1
		Matrix Analysis	Competitor Product Components	6	1			
		Machine Design (Formulae)	Engineering Metrics	8		1		
	Product Design Specification	Statement of Needs	Targeted Engineering Metrics	7	1			
		Optimisation Problem Formulation	Trade-Offs	7	1			
	Conceptual Design	Concept Generation	Concepts	8	1			
		Concept Selection	Concepts and Selection Criteria	8	1			
	Detail Design	Components and Parts Embodiment Design	Components and Parts	8	1			
	Manufacture	One-Off Manufacturing	Prototypes	9		1		
		Batch or Mass Manufacturing	Manufactured Items	9				1
Selling	Marketing - Distribution and Product-Need Mismatch		10				1	
			11					
	Design for X	X (i.e. Manufacture, Assembly, e.t.c.)	12		1			

Table 13: Total Design Techniques Data Matrix (the Vee Lifecycle can be noted as depicted by the digit “1” in the Data Matrix.)

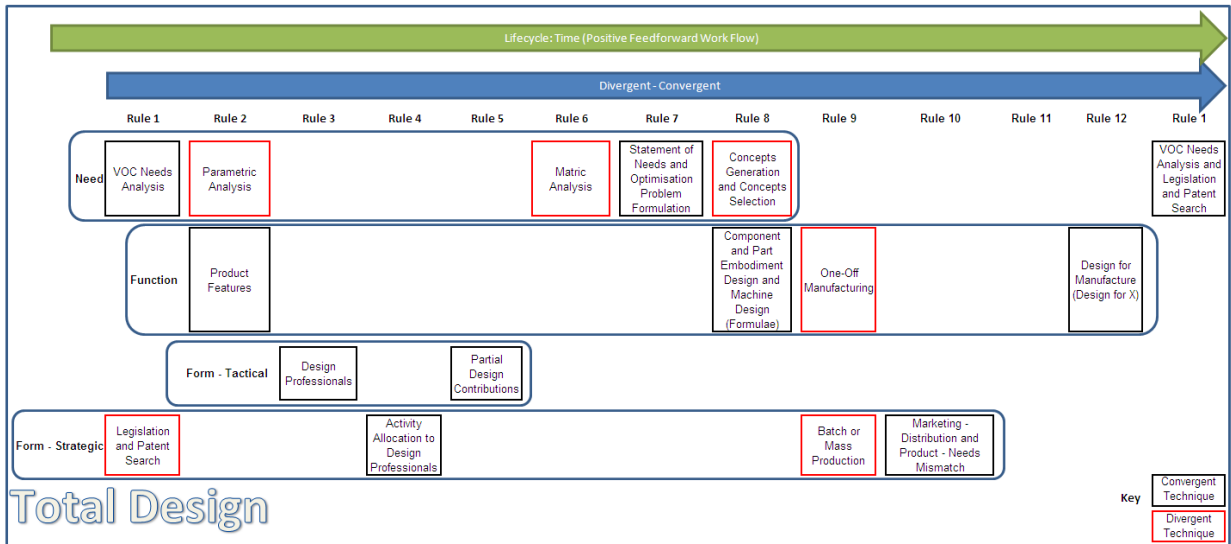

Figure 35: Typography of Total Design (Source: Adapted from Pugh, 1991)

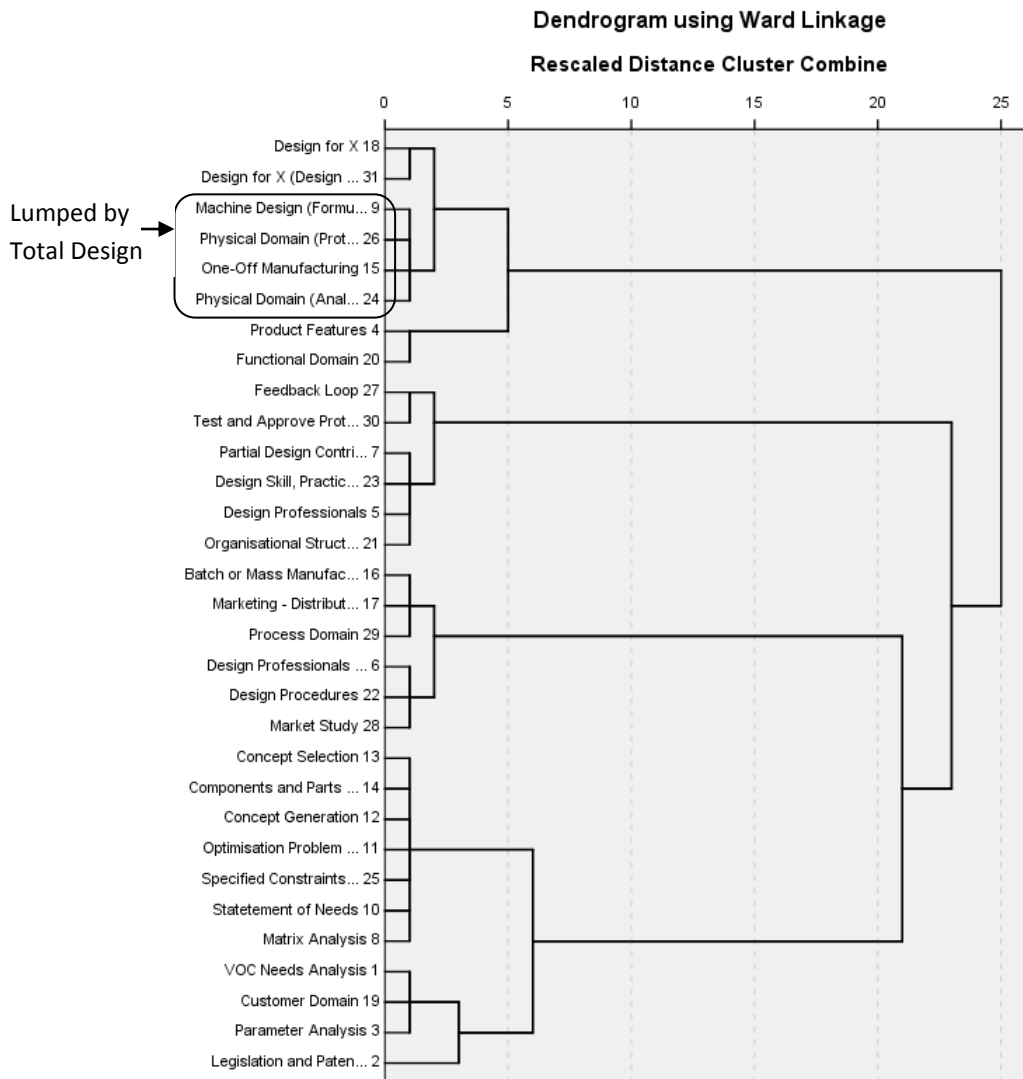

Figure 36: Classification Tree that shows the similarities between the designer's toolkit of Total Design and Axiomatic Design (Ward Linkage Dendrogram with z-score Transform Values)

The classification tree of techniques used to operate the product design methods by means of cluster analysis indicates the different terms or names that are used to refer to the same technique and provides a means and justification to construct a product design repository that standardises representations (both the vocabulary and graphically) used by design professionals and to support training in product design. The product design repository will have advantages of (Skyszman et. al., 2000):

- A. A comprehensive nomenclature, taxonomy or terminology to describe the designer's toolkit to model products;
- B. The terms used in the nomenclature should be a refined set of words with rich and unambiguous definitions that do not overlap – this reduces the number of ways for representation (which become more uniform and consistent);
- C. Equivalent terms are reconciled to minimize the set – in addition, ambiguity is reduced by the reduced number of synonyms i.e. the use of the smallest number of words in the terminology so that a minimal number of words having identical definitions or instances of a word with multiple meanings is arrested;
- D. The nomenclature should provide convergence of efforts from separate and independent design engineers to the highly similar representations with respect to the level of summary or generality;
- E. Facilitate such chores as editing, searching, querying, retrieval and cataloguing; and
- F. Contribute towards the development of standards.

Communication among design engineers distributed across different geographical areas would be simplified by a commonly agreed representation system. The beneficial impact to the product design process will be huge since exploring ideas, quick generation of representations that are easily repeatable and simple to check; relentlessly acknowledging the need for the protection of intellectual property.

The naming scheme used would have three distinct levels of generality: primary (1st) comprised of umbrella terms, secondary (2nd) comprised of techniques and tertiary (3rd) comprised of attributes (Table 13); for example, at RIPCO (B), the techniques associated with a feasibility study, which is an umbrella term, are terms of reference, market feasibility and technical feasibility. Terms of reference, although important for the administration of feasibility studies, cannot be translated into the product therefore they do not provide useful information for the designer unlike market feasibility study and technical feasibility study. The attributes of a market feasibility study are the customer needs and the design principle is the evaluation of these customer needs by the organisation to understand and select those that it can address. At NFTRC the attributes for a proposal, which is also an umbrella term, include objectives, hypothesis, product concepts and method for testing the hypothesis. The proposal would also require breakdown to identify the techniques which in turn must be assessed for their attributes that are useful for the designer.

4.3.2.2 Framing the Hypothesis Test

The objects to be used in the actual tree are the designer's toolkits for product design methods documented in literature and practised in industry. Literature would provide secondary data on nine product design methods, all of which were developed in the most economically developed countries (MDC) and are generally taught in various universities around the world (Figure 5): Axiomatic Design, Stage Gate New Product Development, Quality Function Deployment, Research for Development (R4D), Reverse Engineering and Re-Design, Systematic Engineering Design Approach (otherwise known as Pahl and Beitz Method), Taguchi Methods (otherwise known as Robust Design), Teoriya Resheniya Izobratatelskikh Zadatch (TRIZ) and Total Design. A sample of product design methods practised in Botswana and the United Kingdom would provide the primary data: in Botswana, primary data was collected from RSTI which practice product design towards the requirements of the Botswana National Science and Technology Policy (BNSTP) and the Science and Technology Policy for Botswana. These were BOTEK and RIPCO (B) which are supported by the Ministry of Infrastructure, Science and Technology and NFTRC which is supported by the Ministry of Agriculture; and in the United Kingdom primary data was collected from Progressive Sports Ltd which is a spin-off company incubated by Loughborough University. The study of the techniques in these product design methods is appropriate to assist in recommending suitable methods for the least economically developed countries (LDC). This kind of study has never been done – there is no documented product design method developed in the LEDCs which was found in literature for the duration of this study.

The selection of the documents on which to base particular product design method is based on the citation metrics of both the author, publisher and the journal determined using the Harzing's Publish or Perish software and Google Scholar (Section 2.5).

4.3.3 Kolb's Model

Citing Stice (1987), Otto and Wood (2001) apply the Kolb's model to describe the development of the reverse engineering and re-design methodology. The basic approach of the Kolb's model used in this study is shown in Figure 45. The traditional Kolb' model is central to this basic approach: each of the four distinct areas is actually a learning preference of an individual and can stand on its own but they are arranged in a never ending loop of four distinct stages performed with the help of four product design engineers who were directly responsible for the design of five products through performance management system contracts.

As explained below, the Kolb's model works on two cycles: a four stage cycle of activities (akin to the child's game of bases where the learner or the researcher touches all bases) and a four stage cycle of learning styles (shown by arrows in Figure 37). The two cycles are superimposed on one another:

- Activity 1. Concrete Experience;
Learning Style 1. Diverging
- Activity 2. Reflective Observation;
Learning Style 2. Assimilating
- Activity 3. Abstract Hypothesis and Conceptualisation; and
Learning Style 3. Converging
- Activity 4. Active Experimentation
Learning Style 4. Accommodating



Figure 37: Kolb's Model used at RIPCO (B)

Figure 37 shows the relationship between the case studies carried out and the Kolb's model. The starting activity is influenced by choice on a pair of preference variables described by two axes that dissect the two cycles; each of the axes is delimited by a pair of contrasting modes:

1. The perception continuum which describes the emotional response towards the experience in a mode delimited by feeling or thinking i.e. transfer 'concrete experience' through feeling or thinking to develop 'abstract hypothesis and conceptualisation' – a vertical axis in this study; and
2. The processing continuum which describes the how the task is to be approached in a mode delimited by the doing or watching i.e. gaining experience by doing 'active experimentation' or by watching to make 'reflective observation' – a horizontal axis.

These pair of cycles, together with the dissecting continuum axes, is vital to understanding and implementing Kolb's model.

4.3.3.1 Abstract Hypothesis and Conceptualisation

This stage is the preferred starting point to apply Kolb's model in this study. It involved planning for the validation of proposed engineering product design guidelines. The hypothesis had been developed (Section 4.3.1) and tested or analysed to give the theoretical understanding (Section 4.3.2).

Organisations that are specifically established to innovatively exploit advances in science to provide entrepreneurial technologies may be referred to as research, science, technology and innovation institutions (RSTI); the work environment within which the 1998 Science and technology Policy for Botswana (S&T Policy) and the 2005 Botswana National Research, Science and Technology Plan (BNRSTP) are implemented is comprised of RSTI whose performance may be characterised as illustrated in Figure 38 and Figure 39 (Selaolo, 2007; Keatimilwe, 2005). The technology application and support RSTI are government agencies with one or more departments structured to assist entrepreneurs who source machinery and know-how from the research and development RSTI.

The proposed product design guidelines were scheduled for validation at RIPCO (B), a research and development RSTI that designs and develops machinery. Another possible research and development RSTI that designs machinery was BOTECH, but the logistics would have been difficult for the researcher.

Other research and development RSTIs are generally not suitable for this study because their activities are geared towards advances in nutrition and veterinary vaccines; in principle their definition of the word "product" would more properly mean concepts such as food recipe and vaccine chemical inventions therefore they procure the fully designed equipment suitable for their new found processes and refer entrepreneurs to procure machines from research and development RSTI; however, the process design at NFTRC was incorporated in this study. Background information on idea generation RSTI as well as technology application and support RSTI is given in Chapter 6.

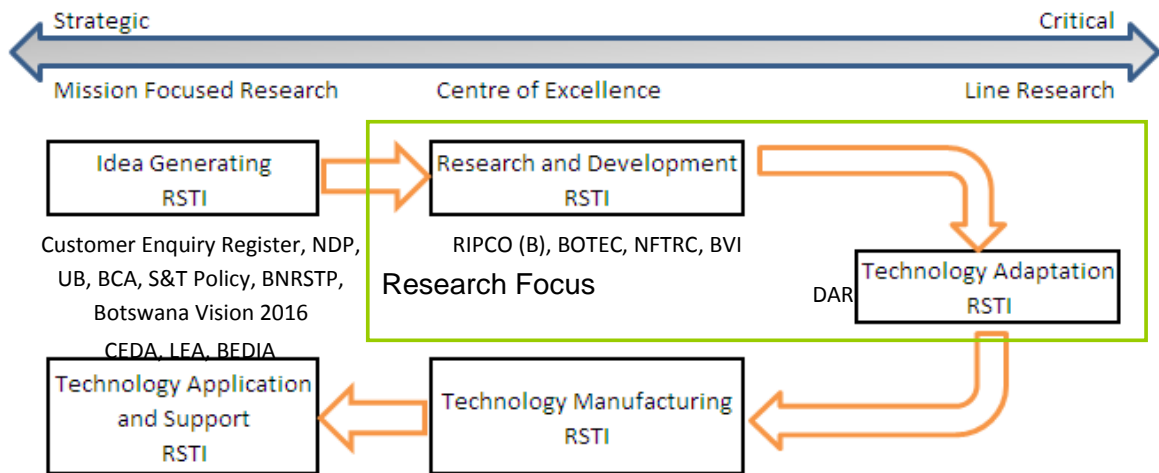

Key:

- BCA:** Botswana College of Agriculture
- BOTEC:** Botswana Technology Centre
- CEDA:** Citizen Entrepreneurial Development Agency
- LEA:** Local Enterprise Authority
- BEDIA:** Botswana Export Development and Investment Authority
- RIPCO (B):** Rural Industries Promotions Company (Botswana)
- UB:** University of Botswana
- BVI:** Botswana Vaccine Institute
- DAR:** Department of Agricultural Research
- NFTRC:** National Food Technology Research Centre
- NDP:** National Development Plan

Figure 38: Research Platforms

The five selected products were already planned in the RIPCO (B) quarterly schedule or customer inquiries register; therefore, no pre-selection was done whilst at Loughborough University. This would ensure that there is no disruption of the RIPCO (B) design activities.

4.3.3.2 Active Experimentation

The following three main tasks were undertaken:

Firstly, the identification of priority areas: The BNRTTP identifies priority research areas which are grouped into three main research platforms (Keatimilwe, 2005; Figure 39). Each of the products that were being designed was mapped according to its BNRSTP priority area with possible propagation to useful linkages to other RSTI.

Secondly, the audit of the RIPCO (B) design process: Analyse the product design method used at RIPCO (B) and identify all design process techniques applied to any previous tasks already performed to design the five products from product files. The five products were at different stages of the design process and in different sections of the technical department. Some work was done on poultry, building brick making and construction rubble hammer-mill products related to energy and civil sections with civil, energy and material engineers

Lastly, the product design guidelines were applied and observations were recorded. This is a critical step on the validation of the proposed guidelines because the details of the design techniques would be applied at this stage. This also gave credibility to continuation of research work after this exercise.



Figure 39: The 3 Platforms and 17 Priority Research Areas of the BNRST Plan (Source: Keatimilwe, 2005)

4.3.3.3 Concrete Experience

The observations of any implementation problems were analysed and evaluated for improvements of the proposed product design guidelines:

- To determine whether the product design guidelines are truly representative i.e. inclusive of the RIPCO (B) product design method. Product design reviews of the five products were held. The guidelines were checked against several other products that had been designed in the past using information from the files to explore the logic of product design theory.
- To investigate the positive and negative contributions of the proposed engineering product design guidelines. The proposed guidelines were applied to some customer inquiries and internal product complaints in registers kept by the Business, Marketing and Extensions Department.
- To verify the added advantage of the product design guidelines within a policy setup of a least developed country similar to Botswana. This involves studying database of products from at least one of the technology application and support institutions– the easiest being CEDA because some information related to their in-house research is available through the internet.

4.3.3.4 Reflective Observation

This stage is concerned with summarizing observations as well as holding tutorials and writing reports on the application of the proposed engineering product design guidelines.

4.4 Findings of the Qualitative Survey of Botswana and United Kingdom Industry

A novice in the engineering product design field needs training on the features of product design methods that are known to work. This section focuses on the product design methods that are used in industry; however, it is necessary to analyse secondary data (documented in literature) to form a structural basis not only because most authors believe that industrial product design methods are adaptation of those taught in educational institutions and are purpose built to suit for the needs of their businesses but also because of the necessity to initially develop a literature-based engineering product design guidelines as scheduled in the research programme, as per the road map for this study (Figure 5).

4.4.1 Literature-Based Engineering Product Design Guidelines – The Templates

The literature-base product design guidelines are derived from product design methods documented in literature and ideally taught in educational institutions. They provide the product design method templates; which mean that once learnt, engineers who are trained in management and engineering techniques can instantly start to design products for effective implementation of projects, programmes and policies. They are popular, useful and purpose built for educational and industrial applications; these include Axiomatic Design, Quality Function Deployment (QFD), Research for Development (R4D), Reverse Engineering and Re-Design, Robust Design, Stage Gate New Product Development, Systematic Engineering Design Approach (also known as the Pahl and Beitz Method), Total Design and Teoriya Resheniya Izobretatelskikh Zadatch (TRIZ). All these were studied during the familiarisation stage when implementing the framework qualitative research approach.

Among other issues, this research explores the nature and form of these product design methods and attempt to understand the procedure for creating new product design methods that are customisable depending on the needs at hand. Most importantly, these product design methods use most management and engineering techniques that are taught in a typical engineering course – once the nature and form of these product design method templates are understood, engineers with a general knowledge of management and engineering techniques can easily custom-build product design methods suitable for their businesses or would find it easy to relate to this study. Although coincidental to this study, it is also important to note that all these methods listed above are acknowledged to originate from the most developed countries (MDC) in the northern hemisphere. No popularly documented and applied product design method was found that originated from the least developed countries (LDC) or any country from the southern hemisphere; therefore this study would be the first of its kind to specifically examine the North-South technology transfer in the engineering product design field. The Axiomatic Design

which is acknowledged to come from North America (Suh, 1990), Total Design which is acknowledged to come from Europe and Quality Function Deployment which is acknowledged to come from Asia are put on the spotlight. The other methods come from the same geographical areas: Stage-Gate New Product Design is acknowledged to come from North America, Systematic Engineering Design Approach and Teoriya Resheniya Izobretatelskikh Zadatch (TRIZ) are acknowledged to come from Europe and Robust Design is acknowledged to come from Asia (Figure 5).

Usually and for most engineering and management techniques documented in literature, the inputs and outputs are descriptions that are typically a textual, mathematical expression or graphical representation such as a block diagram, technical drawing, tree diagram, parametric graph or a matrix. But the processing of some of these techniques requires physical embodiments either in a laboratory or engineering manufacturing workshop. However, it is not rational to meticulously apply a management or engineering technique when it is not required; hence, it is desirable that the choice and application of groups of these techniques is structured. The group of management and engineering techniques that are used to operate the product design process are called the designer's toolkit and are assembled into distinct groupings which together are called the design core; the product design process requires thorough implementation and coordination of both the designer's toolkit and the design core (Pugh, 1991).

After examining the product design methods documented in literature, a thematic framework was developed (Figure 40) – this begins the second stage of framework qualitative analysis. Five key emergent and analytical themes were identified:

1. The need-function-form structure of the product design process;
2. The divergent-convergent structure of the product design process;
 - A. The product development lifecycles;
 - B. The product design drivers; and
 - C. The product realisation activities.

Themes 1 and 2 are emergent themes which were noted during familiarisation stage and themes A, B and C are analytical themes which were noted as patterns of experiences which recurred in the research notes and jottings; all these themes were used in this study to investigate answers to the research questions.

A-Priory Themes – arising from research questions

RO 1 Contextual Research Objective: Identifying the Form and Nature of Existing Engineering Product Design

- RO 1a What are the **perceptions** that are held about existing product design methods?
- RO 1b What is the nature of **experiences** with existing product design methods?
- RO 1c What are the **needs** of design engineers from product design methods?
- RO 1d What **constituents, building block, elements or attributes** operate within product design methods?

RO 2 Diagnostic Research Objective: Examining the Reasons for, and Causes of, existing Engineering Product Design Methods

- RO 2a What **factors underlie the perceptions** held about product design methods?
- RO 2b How is the **decision making** catered for in the product design methods?
- RO 2c Why do **particular needs of design engineers arise** and whether they could be provided by the product design methods?
- RO 2d What is the **limitations** of some product design methods which affect **usage**?

RO 3 Evaluative: Appraising the Effectiveness of Existing Engineering Product Design Methods

- RO 3a How are **design objectives** achieved?
- RO 3b What affects the successful **implementation** of product design methods?
- RO 3c How do **current experiences affect subsequent behaviours** towards product design methods?
- RO 3d What **barriers exist to hinder** product design methods?

RO 4 Strategic Research Objective: Identifying New Theories, Policies, or Action that are or may be necessary for Effectiveness

- RO 4a What **types** of product design methods are required?
 - RO 4b What **actions are needed to improve the effectiveness** of product design methods?
 - RO 4c How can product design methods be **improved**?
 - RO 4d What strategies are required to **overcome any newly identified or defined problems**?
 - RO 4e What and how **new techniques** can be developed to expand the designer's toolkit and thereby identify new engineering product design methods?
-

Emergent Themes - arising from observational notes

1.0 The Need-Function-Form Structure of the Product Design Process

- 1.1 Need
- 1.2 Function
- 1.3 Form

2.0 The Divergent-Convergent Structure of the Product Design Process

- 2.1 Divergent
 - 2.2 Convergent
-

Analytical Themes - arising from recurrence and patterning of particular views or experiences

A Product Development Lifecycles

- Ai Waterfall Lifecycle
- Aii Big Design Up-Front Lifecycle
- Aiii Concurrent Lifecycle
- Aiv Vee Lifecycle
- Av Spiral Lifecycle
- Avi Chaotic Lifecycle
- Avii Unified Process Lifecycle

B Product Design Drivers

- Bi Technological Yield
- Bii Technological Productivity
- Biii Technological Returns

C Product Realisation

Figure 40: Thematic Index

The thematic framework was used to index the secondary data such as books and journals via the research notes (Figure 41). All the data was reviewed and placed side by side with the corresponding themes – note that it is possible to detail the page on the reference from which the data was obtained in secondary data sources. A-priori themes, for example, are assigned to the data that arise directly from the research questions. Also assigned were the emergent themes which arose from research notes and analytical themes which arose from noticeable patterns of views and experiences, all this themes can be identified within the same text or across several texts. Each theme contains its own category of sub-themes (Figure 40): a-priori themes are subdivided into research questions related to particular research objectives; and both emergent and analytical themes are subdivided into working examples.

Suh, N., P., 1990, <i>The Principles of Design</i> . New York, United States of America: Oxford University Press, Inc	
Among intellectual and technological pursuits, design is one of the oldest endeavors. From prehistoric periods, humanity has designed and made hunting implements, shelters and clothing. It might have preceded the development of the natural sciences by scores of centuries. Yet to this day, design is being done intuitively as an art. It is one of the few technical areas where experience is more important than formal education. If the goal of education is to transmit systematic and generalisable knowledge, rather than experience, to those uninitiated in the art and science, design has not yet made the grade as an intellectual discipline, for few schools teach the subject with systematically generalisable knowledge.	RO 4 - Strategic Research Objective: Identifying New Theories, Policies, or Action that are or may be necessary for Effectiveness
Design is clearly one of the remaining intellectual challenges of the twentieth century, and perhaps beyond. Engineers and design are almost synonymous.	RO 3 - Appraising the Effectiveness of Product Design Methods
The decisions that they make during the design stage profoundly affect all those that follow - be it quality of the product, the durability of ancient buildings (some of which still stand today), or in some cases, the ad-hoc decision making process has not been as effective as it should have been. We see many failures of design, some spectacular and many routine.	RO 2 - Diagonastic Research Objective: Examining the Reasons for, and Causes of, existing Engineering Product Design Methods RO 3 - Appraising the Effectiveness of Product Design Methods 1.2 - Function 1.3 - Form
There is a general consensus today that engineering schools must do a better job at teaching design, and must elevate the the importance of design in our curricula. The critical issue is not whether we sholud teach design in our engineering schools, but rather what to teach and how to teach it.	RO 4 - Strategic Research Objective: Identifying New Theories, Policies, or Action that are or may be necessary for Effectiveness
This book presents the principles of design and constitutes the exposition of the design axioms and their applications; the axioms are the basic principles of design.	RO 1 - Contextual Research Objective: Identifying the Form and Nature of Engineering Product Design
This book is intended for both students and professionals.	RO 2 - Diagonastic Research Objective: Examining the Reasons for, and Causes of, existing Engineering Product Design Methods
In some cases the student is expected to define the problem through library research, or even by performing simple critical experiments. The important thing for the student to learn is that the ability to define the problem is the most important and difficult task in engineering (p. vi).	RO 3 - Appraising the Effectiveness of Product Design Methods RO 4 - Strategic Research Objective: Identifying New Theories, Policies, or Action that are or may be necessary for Effectiveness
Although the National Science Foundation (NSF) has tried to strengthen the design field, the community has had problems in defining research agenda and goals, espeacially the intellectual and scientific elements of the design field. Often many educators and engineers try to use computers to deal with design subjects, rather than to comprehend the conceptual aspects of the design process. This field will never develop the requisite intellectual base if we abdicate our power to reason and conceptualise basic principles to the computational power of machines (p. vi).	RO 4 - Strategic Research Objective: Identifying New Theories, Policies, or Action that are or may be necessary for Effectiveness

Figure 41: Indexed Research Notes (Source: Suh, 1990)

In the third stage of the framework qualitative analysis, charts of the secondary data were developed. Charts make data to be visually efficient and are of two types: thematic analysis charts (for each theme across all product design method) and case analysis charts (for each product design method across all themes).

The thematic analysis chart can show information related to the research objectives and questions through a-priori themes (as illustrated in Tables 14 and 15); hence, the answers to the research questions would be partly found because each chart is dedicated to a single research objective and the related category of research questions – the chart titles relate to the research objectives, the chart column headings are key concepts from the research notes and the chart rows record each product design method. Table 14 is useful for authentication of the literature-based product design guidelines e.g. the mapping of the organizational structure of organizations on top of their product design method typology and RSTI on top of the proposed conceptual framework (Section 4.4.2).

RO 1 - Contextual Research Objective: Identifying the Form and Nature of Existing Engineering Product Design Methods			
Product Design Method	Definition of, or Interpretation of the meaning of, Product Design	Types of Product Design Methods/Process/Activities	
Axiomatic Design	Design is a continuous interplay between what we want to achieve and how we want to achieve it and requires the Identification and Application of the Basic Principles of Design	Functional Design: A Segmented but Progressive Functional Decision Making i.e.the earlier a Design Decisions is made the greater the impact or effect on any other decision made after	Design Meetings: Ad-Hoc Decision Making Process
Total Design	A Framework of Activities within which Traditional Subjects such as Mathematics and Physics or other Engineering Topics are placed and thoroughly Practiced	Total Design: Product Design Methods/Processes/Activities that Utilise of a Full Work Complement of All Engineering and Non-Engineering Skills and Techniques specifically required for the Product being Designed	Partial Design: Product Design Methods/Processes/Activities that Utilise a Segment or a Small Proportion of All Engineering and Non-Engineering Skills and Techniques specifically required for the Product being Designed
Quality Function Deployment	The conversion of the consumers' demands into quality characteristics and developing a design quality for the finished product by deploying the relationships between the consumer demands and the quality characteristics.	Design Approach: A method that starts from the upstream end (consumer demands) and moves downstream ensuring quality throughout each stage of product development process towards the finished product	Analytical Approach or Quality Control: A method that starts at the downstream (finished product) point and moves upstream through the product development process searching for factors that contribute to customer complaints.

Table 14: Thematic Analysis Chart of Identifying the Form and Nature of Existing Engineering Product Design Methods

A thematic analysis chart may be developed against more than one research objective especially where the chart column headings between the respective research objectives referred to similar key concepts or to emphasis vital key concepts and make them more noticeable such as to breakdown the Research Objective 1 (Table 14) to show the influence of a particular type of a product design method (Table 15).

The case analysis chart illustrates at a glance the characteristics of a product design method related to all themes and key concepts; in this study, each product design method was consistently ordered against the emergent and the analytical themes (Figure 42). It is important that the same order is kept for each product design method case analysis chart; so that the whole data of each product design method can be easily reviewed and comparisons can be made between, and within, product design methods.

Influence of Design Partitioning						
Product Design Method	Design Team Organisational Structure			Acquisition of Requisite Knowledge		Micro-Components of Product Design
Axiomatic Design	Organisations are designed and created to perform certain tasks that they cannot perform - they are entities with their own goals, resources and capabilities.	Certain common set of goals and objectives are established for everyone in the organisations to simplify coordination of activities towards attaining the specified goals - non-human resources are accumulated to increase the organisational capacity.	In an organisation people with various expertise complement each other - the functional requirements are the goals of the organisation; the design parameters are the sub-units of the organisation to achieve the functional requirements.	The engineer needs knowledge from both the engineering education (to learn scientific principles and methodologies) and engineering practice (for "hand on" experience through usage of the scientific principles and methodology).	The design parameters i.e. the physical sub-units of the organisation must be so chosen that the design matrix become a diagonal matrix - in an uncoupled organisation, each sub-unit of the organisation knows its exact mission and can pursue its objectives; in a coupled organisation, confusion and inefficiency reigns supreme as several sub-units of the organisation try to achieve the same set of goals.	All design decisions obey the two axioms: The Independence Axiom. Maintain the Independence of Functional Requirements (FRs) and The Information Axiom. Minimise the Information Content
Total Design	Team Membership can range from One Designer to Several Designers	Allows for Effective Communications between Design Team Members to integrate their Skills and Work with those within and outside the immediate Design Sphere	Professional Divisions in Organisations and Faculty Divisions in Academic Institutions are representative of Partial Design	Knowledge (i.e. Information, Techniques and Technology) is Acquired through Partial Design Educational Programmes	Design Teams Organisation directs the Contribution of Partial Design Methods/Processes/Activities in a disciplined and structured manner related to Total Design i.e. coordination through the common theme of Total Design.	Analytical and Physical Embodiment as well as Engineering and Non-Engineering Designer's Toolkit comprised Technology-Dependent and Technology-Independent Techniques. This may involve the evolution of Design Core Activities, Iterative Design Activity Flow with Main Flow and Reverse Flow Modes
Quality Function Deployment	Requires the deployment of quality functions (i.e. the human and non-human resources of departments responsible for quality) of a company	QFD study meetings are used in the initial stages and experimentally implemented on key subsystem; then a design team (functional team) is organised to gradually introduce quality deployment into organisational operations	QFD refers to functions responsible for quality in a company's areas of design, manufacturing, service, and so forth.	New products and technology are imported nationally so that similar products could be made internally in industry through analysis of warranty claims by eliminating factors contributing to problems (and indicated in a cause and effect diagram to be acted upon to prevent their recurrence) - i.e. an initial analytical approach . Based on knowledge acquired through the analytical approach, technology begins to accumulate, better quality than original can be achieved through the design approach .	New product development takes place in parallel with the manufacture of existing products e.g. if quality function deployment is introduced in model A, the results of that experience can be used in model B's technology deployment without having to wait for the completion of the model A.	quality deployment charts, tables, and descriptive matrices. QFD implementation starts with the Design Function (i.e. the Design Department) and moves to other stages of the product development process.

Table 15: Thematic Analysis Chart to Emphasize the Influence of Partial Design

Case Analysis	Total Design
1.1 Need	All design starts, or should starts, with a need that, when satisfied, will fit into an existing market or create a market of its own. From a statement of need - often called the brief - a product design specification (PDS) must be formulated - the specification of the product to be designed.
1.1 Need and 1.2 Function	Conceptual design is applied within the envelope of the PDS, and this applies to all the succeeding stages until the end of the core activity.
1.3 - Form: Design Team Intentions Communication or Planning	The approach taken in this book will enable you to work in an integrated manner, either singly or in a team. It will also help you to communicate to others (both within and without the immediate design sphere) just what your intentions are, and why (p. viii).
1.3 Form: Design Team Skills Integration	If you were to consider almost any product, you will find that the product itself would have required inputs from people of many disciplines, both engineering and non-engineering, in a mix that was almost unique to the product under consideration. To conceive such products would therefore have required coordinated efforts from different specialisms (p. 1).
1.3 Form: Design Team Professional Divisions	To ensure achievement of engineering competence, the major part of any engineering course will be necessarily taught (in a product sense) as partial design . You will see that this represents the professional divisions of most universities, polytechnics and colleges, and indeed industry (p. 1 - 2).
1.3 Form: Design Teams Partial Contributions or Job Descriptions	These deficiencies have to be recognised otherwise misdirected rigor will always give to bad total design. This implies that design teams should always include non-engineers (p. 4). It is also preferable that partial design contributions should be disciplined, structured and related to total design (p. 4).
Av Waterfall Lifecycles	The main design flow is from market (user needs) to sales. The main design flow is itself an iterative process.
Av Vee Lifecycle & Av Spiral Lifecycle	The main design flow can, and does, often reverse at any point in the design activity and some iteration is inevitable, but operating within the design core rigorously and systematically will minimise unnecessary iteration.
Avi Chaotic Lifecycle & Avii Unified Process Lifecycle	Iterations occur because of changed circumstances leading to the evolution of the PDS.

Figure 42: Sample from Total Design Case Analysis Chart

The last stage of the framework qualitative analysis involved reviewing, comparisons and contrasting all thematic and case analysis charts and research notes with the aim of:

1. Defining product design;
2. Mapping the range of application, types or nature of product design;
3. Creating typologies;
4. Finding associations;
5. Providing explanations; and
6. Developing Strategies.

Product design may be defined through the use of terms and phrases such as framework, principles, decision-making, information processing, problem-solving and solution-elements. This study proposes twelve design rules and three attributes that are common to a well designed product.

The selection of which design rules to use will depend on the issues such as the quality of information available or the extent of the design problem assigned to the design professional; however, it should be noted that the initial acquisition of the product design drivers i.e. the design rules 1 through 7 are vital for cost minimization.

The different product design methods use a subset of the twelve design rules and all of the three attributes and in each case use different terminology to refer to the same technique and attribute but the description of the design principle or rule is almost always the same. For example, customer domain, and societal needs as used in axiomatic design refer to the demanded quality and consumers demands and expectations used in quality function deployment (Figure 43) – even total design uses voice of the customer, needs analysis and user needs (Figure 35).

A tree diagram derived through cluster analysis makes it easier to show these similarities and comparisons between the various product design methods which are documented in literature and practiced in industry.

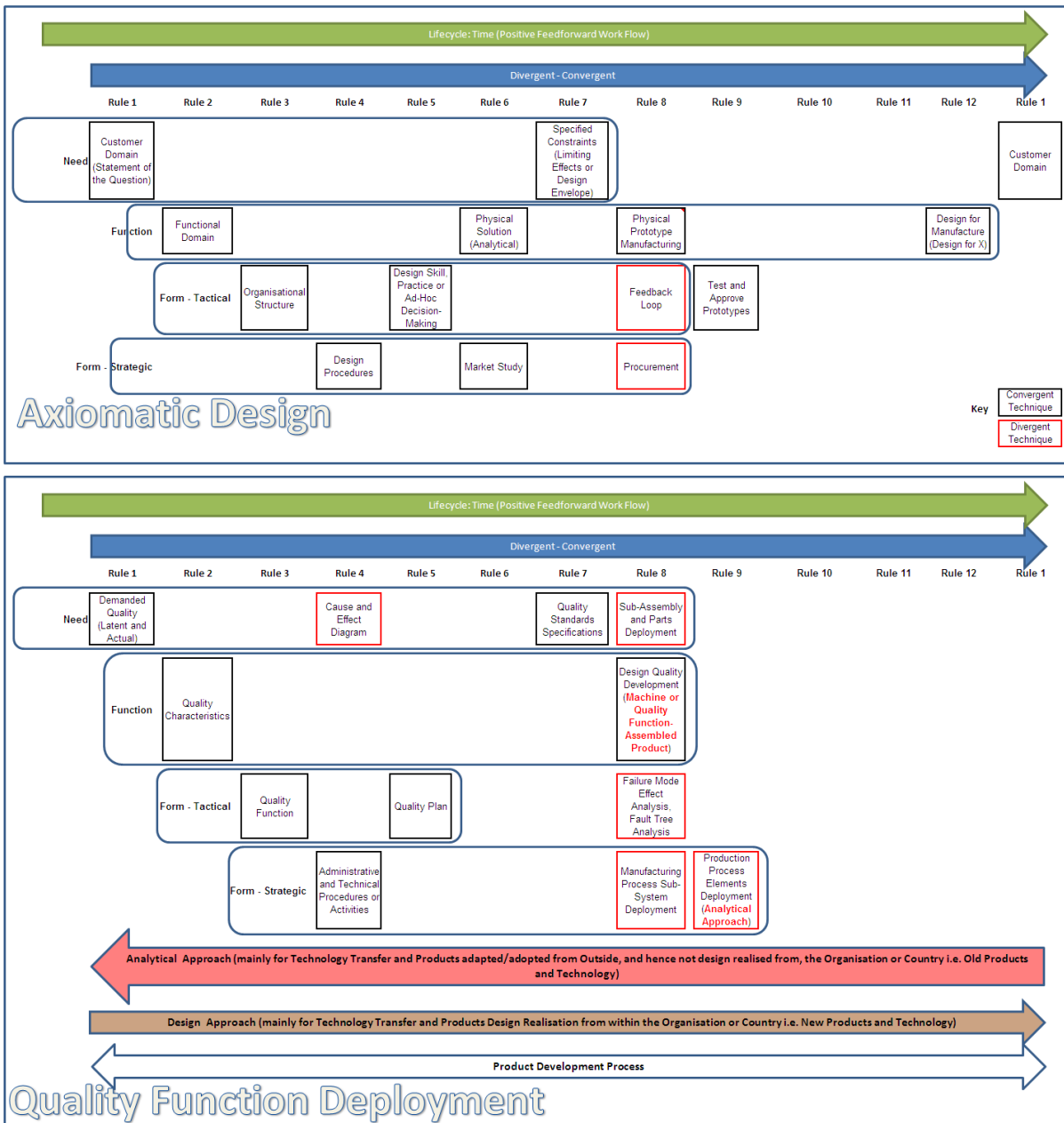

Figure 43: Topology of the Axiomatic Design and Quality Function Deployment

4.4.2 Industry-Based Engineering Product Design Guidelines

The proposed literature-based product design guidelines were subjected to two tests: firstly, they were authenticated against existing product design methods used in industry; secondly, they were tested through case industrial applications jointly with practicing product design engineers (Chapter 6).

In Botswana, product design activities are mainly employed by research, science, technology and innovation institutions (RSTI) as part of research and development activities. The industry – based engineering product design guidelines are derived from product design methods used in research, science, technology and innovation institutions (RSTI).

By its nature, the RSTI employs engineers and other professionals with various backgrounds for product design and development that influences national technology transfer; engineering backgrounds include civil, electrical, energy, mechanical and process engineering.

In Botswana, the RSTI that are inclined to research and development and were studied are Botswana Technology Centre (BOTECH), National Food Technology Research Centre (NFTRC), Rural Industries Promotions Company (Botswana) and University of Botswana (together with Botswana College of Agriculture, its subsidiary).

The product design methods used by the industry in Botswana are compared and contrasted to those used at Loughborough University and Progressive Sports Ltd in the United Kingdom. These are then used to authenticate the literature-based product design guidelines.

The same qualitative research method used to derive the literature-based product design guidelines was used to derive the industry-based product design guidelines. However, the data collection instruments used differs. Questionnaires, unstructured interview through either telephone or face-to-face as well as physical observations were used to gather data from industry.

The questionnaire acted as a topic guide and during the familiarization stage lead to the index categories (Figure 44). From there onwards, the framework approach was very similar to the processing of secondary data (Sections 4.3 and 4.4.1); obviously, the Kolb model was applied in an industrial set-up. In most respects; the organizational structure, the university faculties and the documented method of activities together with the overall management intentions were more visible in industry.

Figure 45 shows the typology (or conceptual framework) of the design methods used at Progressive Sports Ltd and RIPCOC (B). Figure 34 shows the case analysis chart of the product design method used at RIPCOC (B) showing the range of definitions and types of this product design method as well as the organizational structure and the responsibilities of committees according to OP 7.3 Design and Development (RIPCOC (B) Quality Office, 2008). It will be seen that the RIPCOC (B) product design method, like Total Design, delays performing the engineering analysis activity, which essentially requires design principle or rule 6, and compounds it with prototype manufacture which requires design principle or rule 8; this means that the product design specifications are compiled with less than adequate information. Axiomatic design separates the two activities but it lumps Design Rule 3 through Rule 12 together and refers to them as physical domain (Figure 32) – the quality houses used in QFD are only recently moving to quality functions (i.e. departments) which occur earlier than the Design Department and hence QFD still relies heavily on the analytical approach (i.e. quality control) for activities that require Design Rule 6 (Akao 1990).

TOPIC GUIDE (Extract)

1.10 Company Industry
(Please put an 'X' on all appropriate boxes)

<input type="checkbox"/>	Food and Beverage
<input type="checkbox"/>	Chemical and Phamaceutical
<input type="checkbox"/>	Electrical and Electronics
<input checked="" type="checkbox"/>	Machinery
<input type="checkbox"/>	Leather and Textile
<input type="checkbox"/>	Other

_____ (Please Specify)

1.11 Number of Employees
(Please put an 'X' on the appropriate box)

<input type="checkbox"/>	1 - 6
<input type="checkbox"/>	7 - 25
<input type="checkbox"/>	26 - 100
<input checked="" type="checkbox"/>	If > 100 Please Specify

_____ 283 _____ (Please Specify)

3.1 Fill in a description of the design method followed in your company (including responsible committees, engineers, e.t.c)

3.2 How does your company organise for product development and how do you perceive its success on a scale of 1 - Poor, 5 - Good?
(Put an 'X' on the appropriate box)

<input checked="" type="checkbox"/>	Functional Teams	<input type="checkbox"/>	<input checked="" type="checkbox"/>	<input type="checkbox"/>
<input type="checkbox"/>	Matrix Teams			
<input type="checkbox"/>	Project Teams			
<input type="checkbox"/>	Other			

_____ (Please Specify)



RESEARCH NOTES AND JOTTINGS

Product Design Method: Human Resource Baseline paying attention to company's mission, sex, age and skill; Organisational Structure and Communication Flow Requirements between Employee Grouping with respect to the Product Design Method such as Committees, Department and Product Development Teams.



Index (Extract)

Company Industry Index: Comapany Index by Name , Company Index by Product, Company Index by Possible Imports, Company Index by Possible Exports, Company Index by Town/City and Country, Company Index by Industry

Figure 44: Development of Company Industry Thematic Index

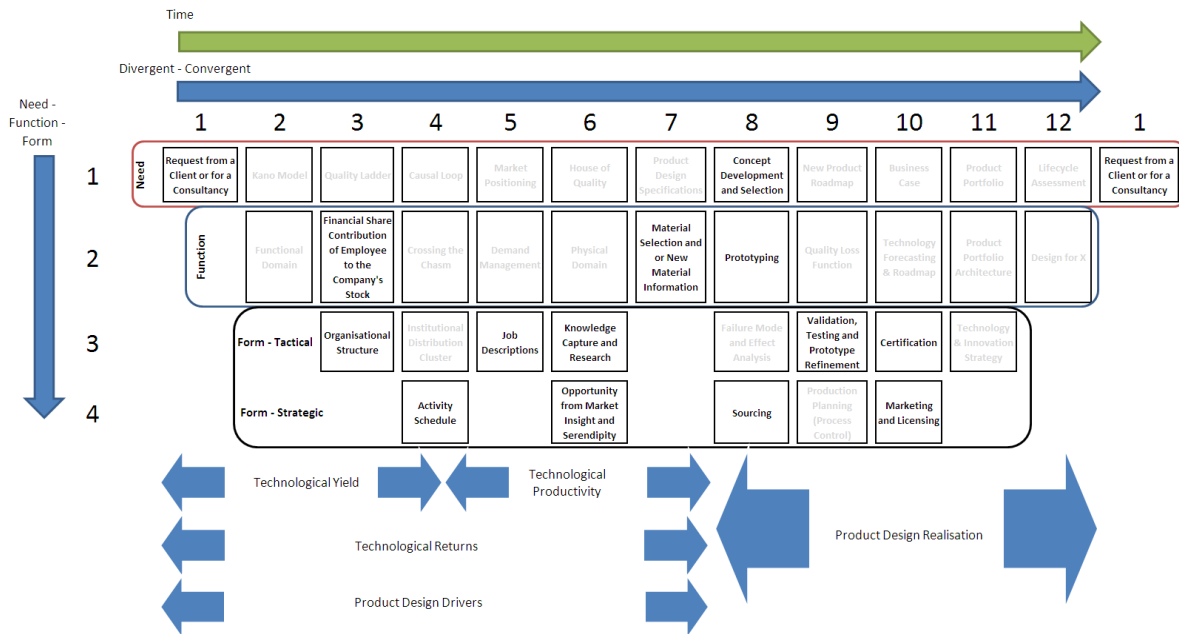

[Progressive Sports]

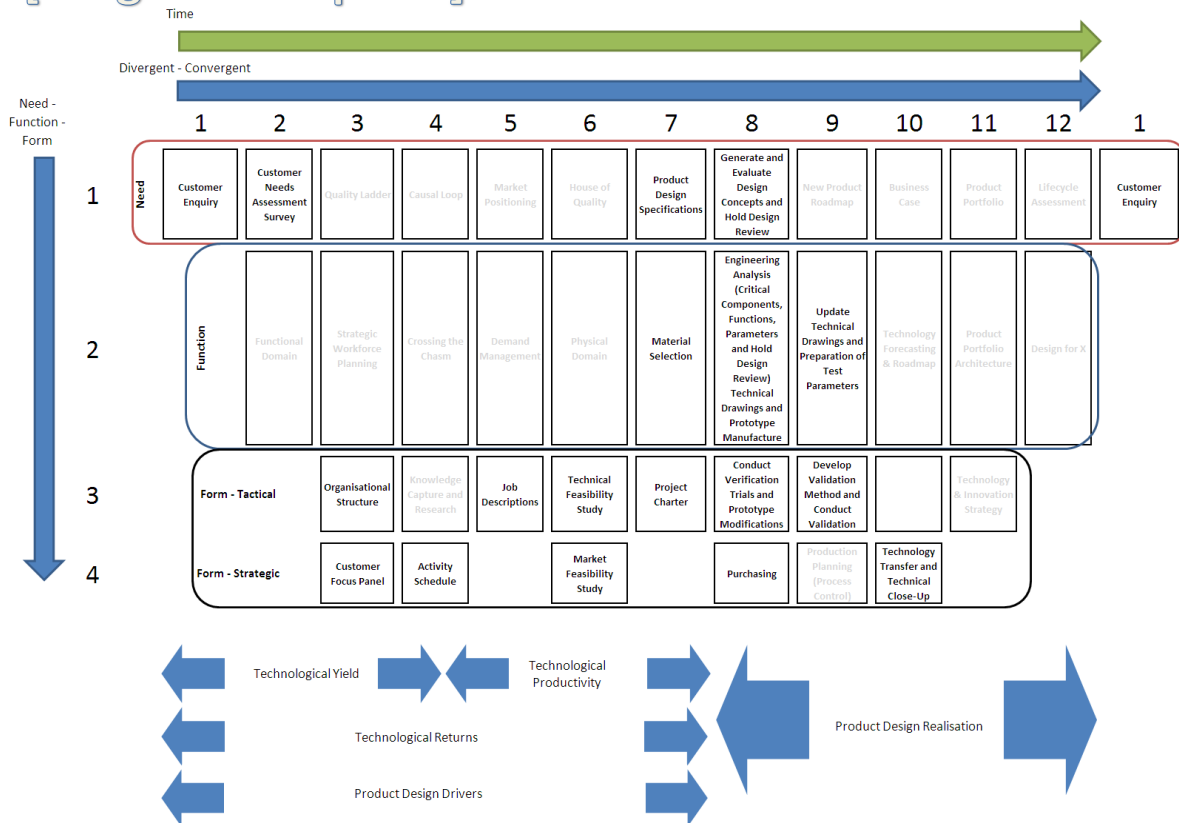

Figure 45: Design Method at RIPCO(B) and Progressive Sports Ltd

4.4.3 The Structure of Product Design Methods

Techniques are used to enable the efficient and effective practice of design and all techniques that are necessary to enable the practice of design may be called the designer's toolkit (Pugh, 1991). A general plan of action and the sequence of activities which the designer or design team expects to take to carry out the plan

may be referred to as a design method. This includes the decisions made by the designer or design team which should not be approached by ad-hoc manner (Suh, 1990). It is essential to appreciate from the outset the entire general plan of action and decision-making when complete with the designer's toolkit.

Dym et. al. (2005) advise that the divergent-convergent thinking is an integral part of design. Cross (1994) refers to "random search" as a divergent design approach as opposed to "pre-fabricated strategy" which may be referred to as a convergent approach and recognizes that while the overall product design is convergent, it "will contain periods of deliberate divergence." The divergent-convergent decision making may not be only be restricted to the overall product design but may also be exhibited in these "periods".

Concept generation and concept selection may be taken to represent one such a "period". One of first tasks in the generation of new concepts is to understand, consider and determine what products must do to satisfy customers. Current research points to three ways to understand this period with design:

1. There must be an initial thoughtfulness on the part of the designer or design team towards the often unstructured customers' needs from which the inputs to the products would be identified. Such inputs would then be processed by products to produce identifiable outputs that are desired by the customer; such a product process, when considered without due attention given to how they will be physically implemented, is called a product function and may be captured through block diagram known as a function structure (Pahl and Beitz, 1986). A function structure describes the inputs, processes and outputs that must occur for the product to work satisfactorily.

For most products, it is possible to partition the function structure into sections that correspond to physical sub-assemblies through the determination of several product architectures that establish the effective layouts of sub-assemblies and components; a choice of product architecture, from among alternatives, must be made taking into consideration the skills, capacity, management complexity and the ability to innovate of the organisation (Ulrich, 1995). The act of constructing the product architectures "transforms product function to product form"; this demonstrates the need – function – form structure of design (Wood and Lindsey, 2006). It should be noted that this occurs within the concept generation and selection "period" (Figure 46);

2. One divergent approach that is used to establish product architectures is the morphological matrix (Fagnoli et. al., 2006). One side of the matrix is labelled with sections of the product functions, whilst the other side is labelled with the physical components or sub-assemblies. From each component or sub-assembly labelled column or row, a single selection is made for possible inclusion in the concept. A concept would therefore comprise a physical component or sub-assembly that performs part of the overall product function; and

3. Frey et. al. (2007) developed a model-based evaluation which they refer to as the “Pugh Controlled Convergence” (PuCC) and is operational during concept generation and selection “period”. PuCC requires:
 - a. The generation of several concepts through divergent approaches;
 - b. The evaluation exercise is performed through a matrix, referred to as the Pugh matrix, which has two important purposes:
 - i. One side of the Pugh matrix is labelled with the concepts that would have been generated;
 - ii. The other side of Pugh matrix is labelled with a selection criteria; and
 - iii. The selection of a datum concept and the convergence of skilled judgment based on investigation and comparison to the datum concept.

The main aim of PuCC is to converge into a highly competitive concept and concepts that are judged as inferior are refined to attack their negative areas of poor performance or are eliminated from further consideration.

Other divergent approaches may be equally used instead of the morphological matrix; however, it purposefully used here to contrast it with the Pugh matrix and product architectures. It should be realised that the morphological matrix and the Pugh matrix contain the column labels which are different from the row labels. Consequently, the rows may have a different number of cells as compared to the column and the attitude for developing the morphological matrix is to increase the number of cells for the physical components or sub-assemblies - a characteristic of a divergent approach when represented by a matrix; while the attitude for developing the Pugh matrix is to reduce to number of physical components or sub-assemblies – a characteristic of a converging approach.

On the other hand, Pimmler and Eppinger (1994), Browning (2001) and Sosa et. al. (2004) used a similar approach to represent the product architecture; however, the resulting matrix always had identical labels for rows, columns and the diagonal. This is because the same sections of the product function albeit representing physical component and sub-assemblies were used to label the row and column. Such a matrix, with identical labels for the row and the column is referred to as the design structure matrix (DSM) (Steward, 1981). The DSM is therefore used to represent the product function as product architecture. In this case, the number of cells to represent the physical components and sub-assemblies is static, neither being increased nor being reduced; in essence, the datum concept freezes, and provides emphasis on, the product architecture to harmonise the comparison rating – a convergent approach.

The matrix may be used to represent the designer’s toolkit if it could be represented as rows and columns illustrating the divergent approach, convergent approach and the need – function – form structure (Figure 46; See also Section 4.3.2).

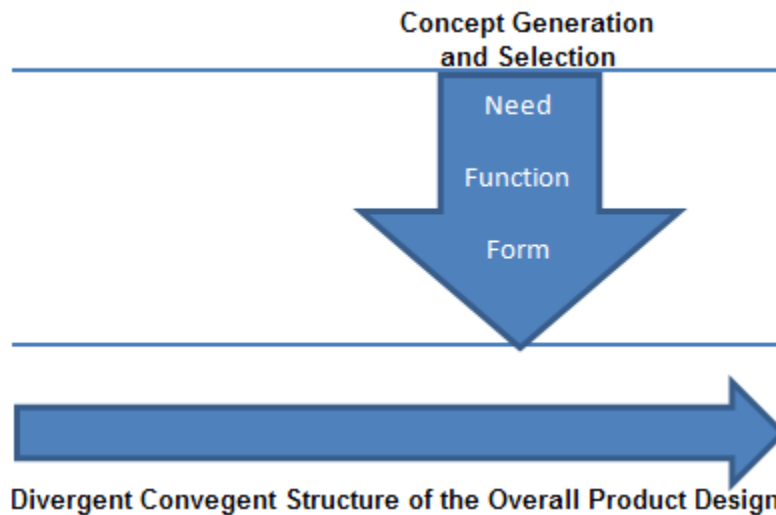

Figure 46: The Divergent - Convergent Structure of the Overall Product Design and the Need - Function - Structure Localised to the Concept Generation and Selection "Period" (Source: Adapted from Cross, 1994)

4.4.3.1 The Product Design Activity Workflow or Lifecycle involved in Total Design

Oliver et al (1991) suggests that tasks can be thought to be comprised of technical methods and a management process; management processes would determine the order or sequencing of the tasks for any undertaking and to establish the transition criteria for progressing from one task to the next whilst technical methods would primarily focus on how to navigate through each task and how to represent deliverables; in other words, the objective of the management process would be to organize the technical process through a workflow or life-cycle.

The Total Design product design method will be used to explain the workflow of the product design activity; however, any of the other types of product design methods may be used. According to Pugh (1991), the workflow of Total Design is defined through a "central design core of activities" consisting of market/user needs, product design specifications, conceptual design, detail design, manufacture and sales (Figure 47). The workflow is presented as a one dimensionally directed sequence of the core activities with the main flow starting from market/user needs to sales. This kind of organising activities is referred to as the waterfall lifecycle (Boehm, 1988). Normally, several core milestones would be defined as deliverables to coincide with the end of each core activity (Department of Defense, 2001; Amber, 2005).

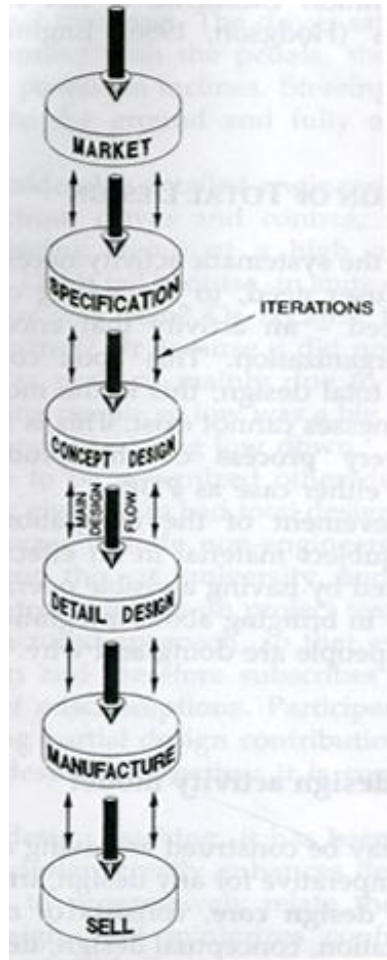

Figure 47: The Workflow of Total Design (Source: Pugh, 1991)

However, it should also be noted each core activity is grouping of techniques as clearly illustrated by Figure 16, Figure 17 and Figure 47. For example, the market/user needs core activity is comprised of techniques which may be categorized according to the divergent approach, convergent approach, need-specific approach, function-specific approach and form-specific approach (Table 16).

Technique	Categorisation	
	Divergent – Convergent	Need – Function – Form
Needs Analysis	Convergent	Need
Parametric Analysis	Divergent	Need
Matrix Analysis	Divergent	Need
Product Features	Convergent	Function
Design Professional Team	Convergent	Form
Partial Design Contribution	Convergent	Form
Resource – Activity Allocation	Convergent	Form

Table 16: Market/User Needs Techniques of the Total Design Method

Each of these techniques may be represented by a matrix according to the findings of Chapter 3. These techniques may then be put together in an affinity diagram that

represents the market/user needs core activity (Figure 48). The layout of the affinity diagram is broken down as follows:

1. The rows represent the divergent – convergent categorisation; and
2. The columns represents the need – function – form categorisation;

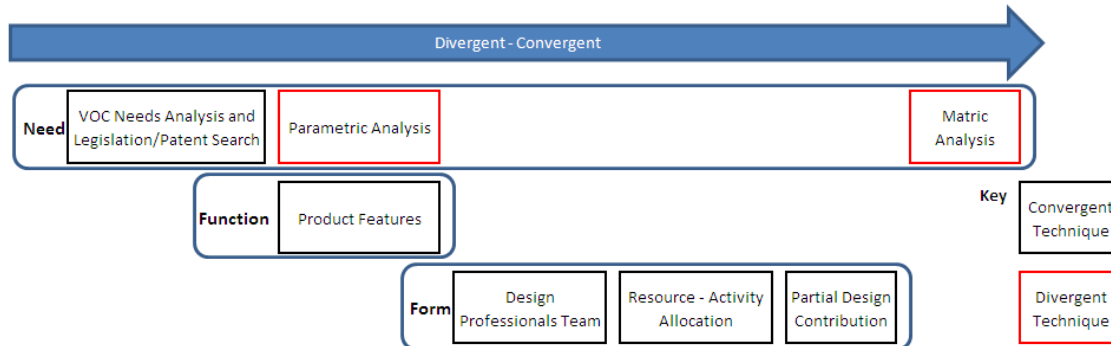

Figure 48: Techniques comprising the Market/User Needs of Total Design Method

Several subjective interpretations about the practice of design may be made from studying Figure 48 i.e. there could be a relationship between the method used to organize the design process and the successfulness of the products (Dyer et al, 1999):

- The divergent – convergent categorization is laid out in a one dimensional sequence that mirrors the waterfall lifecycle of Figure 47;
- The workflow could be front-end loaded with the execution of, or decision making, regarding costly techniques such as the formation of the design team, allocation of resources preceded by less costly techniques – such an organisation of activities is referred to as big design up-front and has advantages of early uncovering incompatibilities and other errors before most costs are locked in (Dean et al, 1997); hence, because of the organization of the techniques, early decisions that must be made at the beginning stages of the workflow that become fundamental determiners of all decisions may be made. Such decisions are referred to as the design drivers (Otto and Wood, 2001);
- Several techniques may be conducted in parallel in order to shorten the product development cycle. This is referred to as concurrent engineering (Forsberg and Mooz, 1995);
- The techniques associated with the convergent approach depict resemblance to the descending left side of a “V” similar to the “Vee” lifecycle as explained by Forsberg and Mooz (1995). It would appear that there should be sufficient iteration provided through the assistance of the divergent approaches and this leads to a possible implementation organised as follows:
 - There may be verification and validation which may be achievable through the addition of techniques not currently covered by literature on Total Design;

- The iterations may be linked to product releases as if the entire workflow is organised in a spiral lifecycle. If such product releases inform the direction taken by the workflow such that there is no fixed pre-ordering of the techniques, then the lifecycle becomes chaotic; and
- Finally, deliberate iterations that span the entire need – function – form categorisation may be introduced in any core activity for an organisation that reflects the unified process.

These subjective interpretations would require research methods with bias towards objective interpretation and would require the application to other types of product design methods (Section 4.3.2).

4.4.3.2 The Product Design Activity Workflow or Lifecycle involved in Research for Development

The IDRC utilised the programme – focused research for development approach to design sorghum milling products and is described in a case study by Schmidt (1987). The research-for-development method has been used by the International Development Research Centre (IDRC) in Sub-Saharan African countries including Botswana, Burkina Faso, Gambia, Ghana, Lesotho, Malawi, Mali, Niger, Nigeria, Senegal, Sudan, Tanzania, Uganda, Zambia and Zimbabwe as well as India and Bangladesh. The core activities for the research-for-development are identification of a problem or opportunity, establishing selection criteria for potential solutions, generation of a technology (through either adoption, adaptation or invention), verification of the solution and bringing the technology into wide spread use.

Like Total Design (Section 3.1.3), each core activity in any of the research-for-development approaches is grouping of techniques. For example, the needs assessment core activity is comprised of techniques, which are comparable to the market/user needs in Total Design; these techniques may be categorized according to the divergent approach, convergent approach, need-specific approach, function-specific approach and form-specific approach (Table 17).

Technique	Categorisation	
	Divergent – Convergent	Need – Function – Form
Recognition of a Problem	Convergent	Need
Characteristics of the Problem	Divergent	Need
Definition of Beneficiaries	Divergent	Function
Sustainability Issues Aspects	Divergent	Function
Organisational Strategy Check	Divergent	Form
Establishment of Agenda	Divergent	Form
Data Collection Planning	Convergent	Form
SWOT Analysis	Divergent	Form

Table 17: Needs Assessment Techniques of the Research-for-Development Method (Source: Adapted from Schmidt 1987 and Laws et. al, 2003)

Just like the market or user needs, the following layout results if each of these techniques may be represented by a matrix then be put together in an affinity diagram (Figure 49):

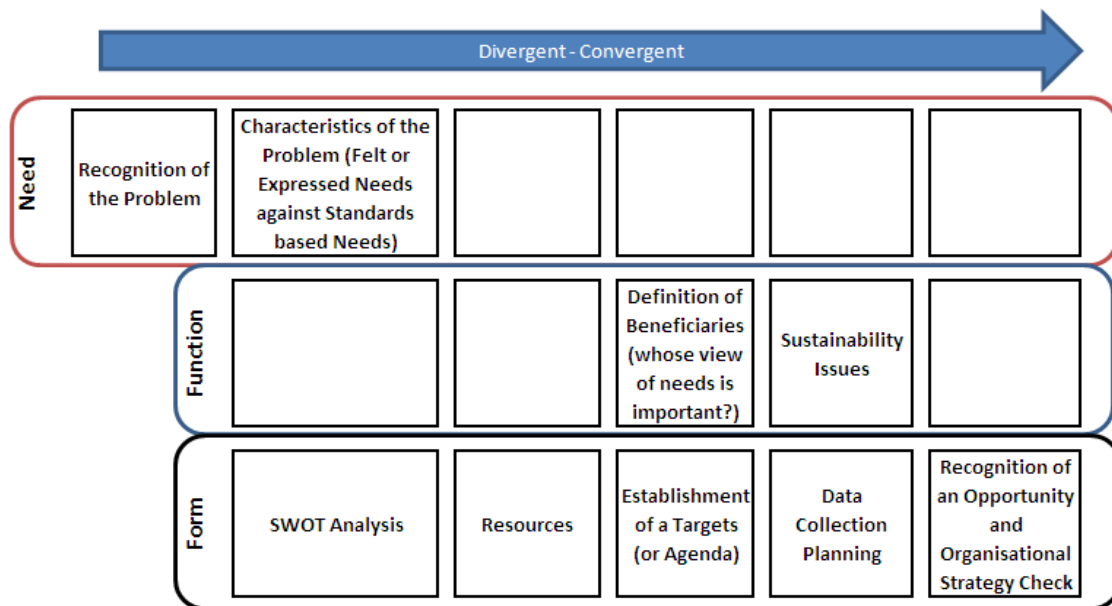

Figure 49: Needs Assessment Techniques of the R4D Method

This shows that the product design methods practiced in industry may also have similar characteristics to those presented and taught in educational institutions in (Section 4.3.2).

4.5 Discussion of the Qualitative Survey Findings

The engineering techniques that are used to operate the product design method are referred to as the designer's toolkit. The designer's toolkit can be arranged as a topology of a set of design tables which are related to one another by a set of specific design rules. The content of each design table is organised in rows and columns of attributes that relate to the human needs, product functions and forms from human - product interactions. This organization is referred to as the need – function – form structure of the designer's toolkit.

The relationship between design tables is achieved or established via attributes; the human needs attributes are transformed to generate product functions attributes or human - product interaction attributes and vice-versa.

The design principles that control the need – function – form structure of the designer's toolkit select the design rules that are used by each design table; in this way an engineering technique is represented as a design table. Consequently, some engineering techniques can be represented as design tables with design rules that exclusively direct human needs attributes, exclusively influence product functions, or regulate the human - product interaction attributes or combination thereof. The design tables whose rows and columns contain contents that are exclusively of

either human needs attributes, product functions attributes or human-product interactions attributes are referred to as convergent but those whose rows and columns contain contents are inclusive of combinations of human needs, product functions or human – product interactions are referred to as divergent. On a macro level, the design rules organise the designer's toolkit in a divergent – convergent structure; on a micro level, the design rules organise the design tables attributes i.e. the rows and columns. The representation tools that are used to analyse and report outcome of these design tables are either textual, mathematical expressions, graphical or physical embodiments e.g. worded descriptions, mathematical equations, technical drawings, block diagrams, tree diagrams, cross plots, matrices or prototypes (both hardware and software).

Management techniques arrange engineering techniques in a periodic sequence through the use of the representation tool types in a manner useful to pre-determined objectives. Periodic sequences are time dependent which, together with design rules, is a factor responsible for product development lifecycles. Effectively, product development lifecycles introduce timely application of design rules in the designer's toolkit.

For material cost effectiveness, the product development lifecycle should manage the designer's toolkit such that the intangible representation tools are executed at the beginning of the product design process. This allows pertinent knowledge to be accumulated and analysed before the creation of any physical embodiments which are materially costly by nature – the proposed product design guidelines break the product design process into two stages: an initial stage that is comprised entirely of intangible analytical and reporting tools and a second stage comprised of a mixture of physical embodiments as well as analytical and reporting tools. Through this arrangement, the product design process could be armed through intangible representation tools to accumulate and translate knowledge into physical products; knowledge gained from analytical and reporting tools is referred to as product design drivers, knowledge assets or technological returns – in whichever product design method is undertaken, the product design drivers enable the design professional to compile the product design specifications. Product realisation uses a mixture of intangible analytical tools and physical embodiments to transform the knowledge assets or the product design drivers.

The product design drivers have two segments: technological yield or R&D yield and technological productivity or R&D productivity. The aims of gaining knowledge assets or R&D is to ensure improvements in technical performance within the limits set by laws of nature. Technical potential is the difference between the current technical performance and the technical performance limitations set by laws of nature. Technological yield is a measure of the extent to which the technical potential is translated into actual technical performance. Productivity is the ratio of change in output to the change in input; hence, technological productivity is the ratio of the improvement in the technical performance of a product to the increment of the effort

required to gain that improvement in the product technical performance. Both the technological yield and technological productivity are each concerned with whether the technology is applied in the right context. All these are technical performance measures that are part of the product design process and should be achieved with the aid of the analytical and reporting tools i.e. the design professional ought to know and understand the technical performance limits of their technologies.

Because the technologies available to the least developing countries (LDC) are different from those available to the most developed countries (MDC), the demands of the product design process on the design professional differ between the two types of countries; this is despite the fact that the product design process may very well be similar – a fact supported by the primary and secondary data in this study (Section 4.4.2). This has to do with the manner in which the technical performance measures are done. Any country that wishes to transform its economic base into one that is heavily dependent on engineering product design should add these technical performance measures as economic factors contributing to the gross domestic product (GDP). Botswana is a case in point. The analytical and reporting tools such as the quality ladder, causal loop, organisational structure and technology adoption curve need to attract more attention to the technologies available to, and in the product design processes of, LDC as proved by case applications – and these need to be applied first through an analytical approach (Chapter 6). Otherwise the national technical productivity would be inherently low.

Product realisation introduces physical embodiments early on before relying more on other analytical and reporting tools. An important analytical and reporting tool that precedes physical embodiments is the product design specification (PDS) – whether a design approach or an analytical approach is being undertaken. The PDS depend on the product design drivers to set targets to technical performance parameters. The tendency to develop the PDS immediately after customer inquiries are captured would lead to product failure subject to the experience of the product design professionals (Figure 50) – the experience of design professionals is a core component of the organisational structure and job descriptions (Appendix 8) which are analytical and reporting tools that are part of the proposed product design drivers. In other words, less experienced design professionals would have to concentrate more on the product design drivers techniques such as quality ladder to get an understanding of the implications of the technologies that are available to them and the extent of their limitations which may be in terms of such factors as cost and time. Perhaps less experienced design professionals in MEDC manage because there is more variety of high standard technologies, therefore they could afford to leave out certain techniques. In Botswana, rushing to do product design specifications without analysis of the product design drivers, for example with respect to the BNRSTP and the S&T policy, would be disastrous. This point is emphasised by the product design guidelines (Figure 51).

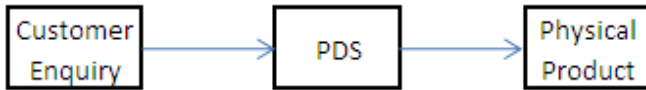

Figure 50: Product Design Process without Product Design Drivers

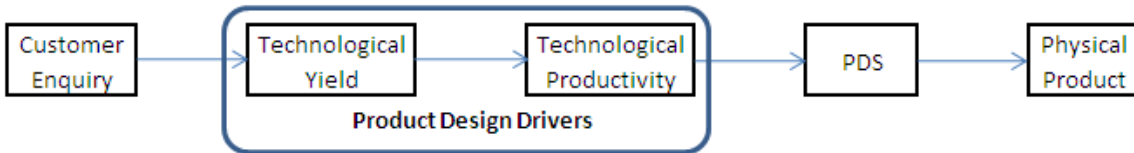

Figure 51: Product Design Process with the Proposed Product Design Drivers

This study proposes product design guidelines that aim to contain a representative number of management and engineering techniques required by product design methods; put another way, the product design methods should comprise a meaningful choice of engineering and management techniques that are a subset of the designer’s toolkit of the proposed engineering product design guidelines. It may not be far fetched to state that a means of achieving good designs is to use all techniques in the product design guidelines. This could be achieved by systematically arranging different organizations but all design professionals need to know which information to extract from reports. The product design methods would then become templates ready for use by design professionals in both educational and industrial organisations. Depending on the initial information available to the design professionals, a choice of techniques from the designer’s toolkit proposed in this study would enable them to attain their desired objectives.

After learning the product design guidelines, especially the product design method templates, the design professionals can easily begin to design products or adapt aspects of it to suit their business. Also, because the manner in which these product design guidelines were developed is documented, both the conceptual framework and the terminology or glossary could be easily expanded to improve their capabilities by adding new management and engineering techniques – the product guidelines are presented here with notable gaps due to the number of product design methods studied so far and time available for the research (Chapter 7).

Typically, management techniques would start the product design process and the suitable choice of a design approach or analytical approach. In most cases, the desired objectives could be represented by the convergent design table of human needs attributes. By isolating product design drivers and product realisation, the design professionals should be able to choose a combination of convergent and divergent design tables to produce the required final output which is typically a convergent design table of human – product interaction. The product development lifecycle offers an effective means of reducing the number of design tables used in a product design method. In Botswana, the desired objectives are developed by policy formulation processes and can be found in documents such as NDP, S&T policy, BNRSTP and Botswana Vision 2016. Commercial departments of organisations

normally keep a register of customer enquiries. Technical advances resulting from research in educational institutions such as Loughborough University, University of Botswana and Botswana College of Agriculture also provide idea generation.

Representations of the product design method using the product design guidelines can include innovative alphanumeric notations which lead to formation of templates for particular programmes. For example, the least developed countries as classified by the world bank such as Botswana require intermediate technologies (Section 1.2). National programmes such as ISPAAD, CEDA Young Farmers and NAMPAAD could be rolled out with design objectives and clearly selected product design methods represented notation-wise; the issue of notation, including the representation tools, was developed mainly to simplify implementation, and is addressed in Chapter 6.

4.6 Summary

Like the literature review, the product design methods used in industry present a semantics problem – the use of similar or equivalent techniques that are nonetheless called with different names; this is compounded by the use of umbrella terms which in they are used one product design method to refer to single techniques and in another they refer to a grouping of techniques. In this chapter, the presentation of product design methods used in the surveyed organizations and literature begins with a description of the workflow paying particular attention to the name of the technique and the attributes that are required per technique; this simplified comparisons with the proposed conceptual framework. This would effectively increase the vocabulary associated with the designer's toolkit or add new techniques to the conceptual framework.

This chapter has discussed an investigation into current practices in Botswana and knowledge of design methods gained from the literature. Five key themes have been identified which have enabled the creation of a coherent structure, or templates, as a basis for the product design guidelines. Chapter 5 discusses the further development of the design guidelines based on this new conceptual framework.

Chapter 5: Product Design Guidelines (PDG)

5.1 Introduction

This chapter describes the product design guidelines (PDG), in this research; the PDG is a structured approach formulated to aid engineering designers to innovatively solve problems. Products designed using the PDG are characterised by the fact that they satisfy the requirements laid out by the existing product design methodologies (Chapter 3). The PDG are intended for application to problems in the least economically developed countries (LEDC); hence, this approach is most suitable for intermediate technologies (Chapter 1) i.e. to design intentions that evolve appropriate technologies which are indigenous to the LEDC or large scale products normally associated with most economically developed countries (MEDC).

Section 5.2 sketches out the important themes which inspired the PDG and their basis; Section 5.3 identifies the conceptual framework, a unique notation and a configuration scheme which are the features of PDG. Thereafter, a summary is provided in Section 5.4.

5.2 The Underlying Theory of the PDG: A Historical Perspective

The proposed engineering product design guidelines are comprised of a catalogue of the quantitative and qualitative engineering and management techniques used across nine product design methodologies documented in literature (Chapter 3); these methodologies are: Axiomatic Design, Quality Function Deployment (QFD), Research for Development (R4D), Reverse Engineering and Re-Design, Robust Design (otherwise known as Taguchi Methods), Stage-Gate New Product Development, Systematic Engineering Design Approach (otherwise known as Pahl and Beitz Method), Teoriya Resheniya Izobretatelskikh Zadatch (TRIZ), and Total Design. It is observed that engineering designers, especially in the LEDC, are confronted with, and have to choose from among, the many product design methodologies; this is the case even though the world is abounding with examples of product failure across a lot of industrial applications and stretching more than a century (Table 18) – there is need for a product design guidelines that are suitable for their needs.

			Year
Disasters	Marine	Loss of RMS Titanic	1912
	Mining	Senghenydd Colliery	1914
		Creswell Crags	1954
		Markham Colliery	1973
	Structural	Tay Bridge	1879
		Summerland Fire	1965
		Alexander Kielland Oil Rig	1980
	Aerospace	Comet Crashes	1955
		Challenger Space Shuttle	1988
	Nuclear	Chernobyl	1984
	Business	Kodak Infringement	1986
BP Infringement		1998	
Serious Accidents	Automotive	Ford Pinto Fires	1967
		Fiat Mirafiori Fires	1978

Table 18: Classification of Product Failures by Severity (Source: Lewis, 2000)

The engineering and management techniques which are part of these PDG are themselves comprised of constituent fractions or attributes and specific principles or rules that describe the relationships or dependencies between these attributes (Section 4.3.2.1) e.g. Suh (1995, p. 258) states that the customer domain technique:

“consists of the customer requirements or attributes which the customer is looking for in a product”.

According to Pugh (1991), the collection of techniques which are used by the designers or design teams to effectively and efficiently practice design activities is referred to as the designer’s toolkit; Cross (1994) declare that the overall product design process is convergent, however, with periods of deliberate divergence. One such deliberate divergence period, within the product design process, is the Pugh controlled convergence (Frey et. al., 2007). This research focuses on the pattern of these “periods” of divergence within an otherwise convergent product design process.

Otto and Wood (1999, 2001) advocate for another school of thought that suggests the need – function – form structure of the product design process. Citing Hubka et. al. (1988), (Pahl and Beitz, 1996) consent that a technical artefact may be considered as a system connected to its environment by inputs and outputs; furthermore, a ‘function’ is a clear reproducible relationship between available inputs and the desired output. The inputs from the customers are referred to as “customer needs” (Griffin et. al., 1993) and product design process starts, or should start, from these ‘needs’ which are then linked to the engineering measures of product performance. The ‘form’ of a product or component includes shape, colour, texture, product architecture, and other factors related to the structure of the product (Jayanti et. al., 2006); ‘form’ has the ability to induce positive or negative emotions, believes and responses from consumers and is a determinant of a product’s success in the

marketplace (Bloch, 1995). This description shows a human 'need' input – artefact 'function' process – desired output 'form' from the interaction (between the human and the artefact) pattern within the product design process; this pattern receives attention in this research.

Beaton (1980) suggests three different levels by which researchers study patterns: first-order patterns, second-order patterns and third-order patterns. The first order patterns are actual observation of relationships made by the researchers. The second-order patterns are where the researchers study two or more first-order patterns. The third-order patterns denote studies of two or more second-order patterns. The PDG results from a research relating to second-order pattern with respect to the product design process: the divergent – convergent first-order pattern and the need – function – form first-order pattern.

Depending on written texts with reference to research work done on each of the above-mentioned methodologies, the designer's toolkit may appear to be comprised of different sets of techniques. The premise for this research is the fact that these methodologies use different terminology to refer to the same techniques within the designer's toolkit. Indeed, one of the problems that bedevil research in product design is the lack of a design repository (Szykman et. al, 2000). To address this problem, this research observes that techniques, that comprise the designer's toolkit, may be broken down into attributes and unique principles or rules which manipulate the relationships or dependencies between these attributes (Section 4.3.2).

To communicate these relationships or dependencies, the following representation schemes are generally used: mathematical expressions and diagrams (e.g. block diagram, the tree diagram, parametric diagrams); both of these representation schemes are typically accompanied by textual explanations. The matrix is one of the preferred representation schemes in product design practice. Representations through a matrix are two fold:

1. Mathematical Matrix: A rectangular array of numbers, symbols or expressions; examples include the design matrix (used in Axiomatic Design) and
2. Grid Matrix: A graphical format or pattern of horizontal and vertical lines for organising data and information to support decision making to solve problems by evaluating, rating and comparing different alternatives on multiple criteria; examples include the Pugh matrix (used in Total Design), the relationship matrix (which forms the body of the houses of quality in Quality Function Deployment) and the relation matrix (that relates generalised performance parameters to generalised solution principles as part of TRIZ) and the morphological matrix (used to generate concepts in lot of product design methodologies).

This research reviews two types of application of the matrix stemming from an observation that both square matrices and rectangular matrices are used in the practice of product design; for instance, the design matrix is almost always a

square matrix whilst the Pugh matrix is almost always a rectangular matrix. Steward (1981a, 1981b) as cited by Browning (2001) coined the word 'design structure matrix' to refer to a square matrix that has identical row and column labels with dependencies between attributes indicated by numbers, symbols or expressions.

To document the designer's toolkit and since this research is concerned with second-order patterns, it is proposed that:

1. The rows of a matrix may be used to denote the need-function-form structure of the product design process; this effectively defines three types of attributes, where:
 - a. The 'need' row shows the attributes that are concerned with the effect envisioned to be required by the customer in the present or at a future time – concentrating mainly on human needs in the absence of the artefact;
 - b. The 'function' row shows the attributes that are concerned with the purpose to be performed by an artefact being designed to satisfy the envisioned customer need – this excludes the human interaction with the artefact although it acknowledges humans in the artefact's environment i.e. it concentrate mainly on what the artefact can do on its own; and
 - c. The 'form' row shows the attributes that are concerned with the physical manifestation of the artefact function – this deals exclusively with the human interaction with the artefact.
2. The columns of a matrix may be used to denote the divergent-convergent structure of the product design process; these effectively denotes two types of techniques, where:
 - a. The column of a 'divergent' technique are comprised of attributes from the need-function-form structure that are not identical to those indicated by the row; and
 - b. The column of a 'convergent' technique is comprised of attributes from the need-function-form structure identical to those indicated by the row. A convergent technique is inherently represented by a square matrix with the properties of the design structure matrix.

Figure 52 shows part of the 'need' row showing the customer domain which would be represented by rows and columns with identical customer needs and therefore is a convergent technique whereas the relationship matrix would be a divergent technique with customer needs represented on the rows and the engineering parameters represented on the columns.

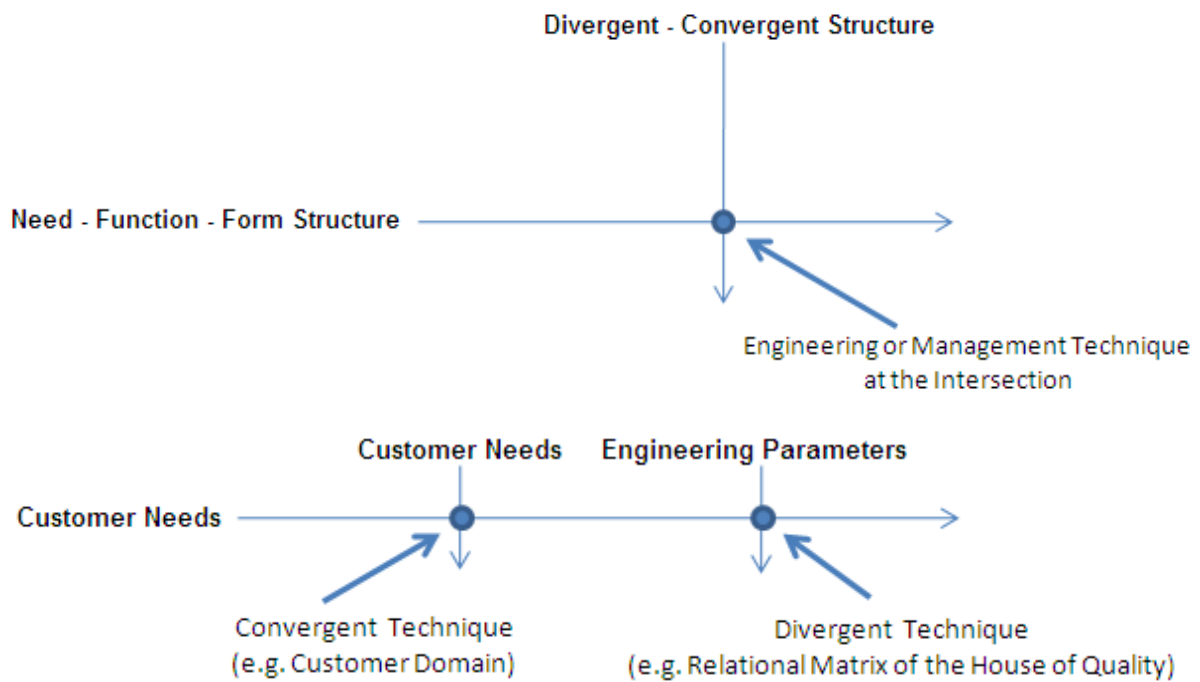

Figure 52: The Intersection of representing an Engineering or Management Technique

5.3 The Features of the PDG: Perspectives on the Organisation of the Designer's Toolkit

5.3.1 The Conceptual Framework: Lifecycles, Product Design Drivers and Product Realisation

A total of forty-two engineering and management techniques that are part of the designer's toolkit have been examined. The following product development lifecycles were instrumental on the development of the PDG which show a continuum of iterations or feedback within and between stages (Figure 53)

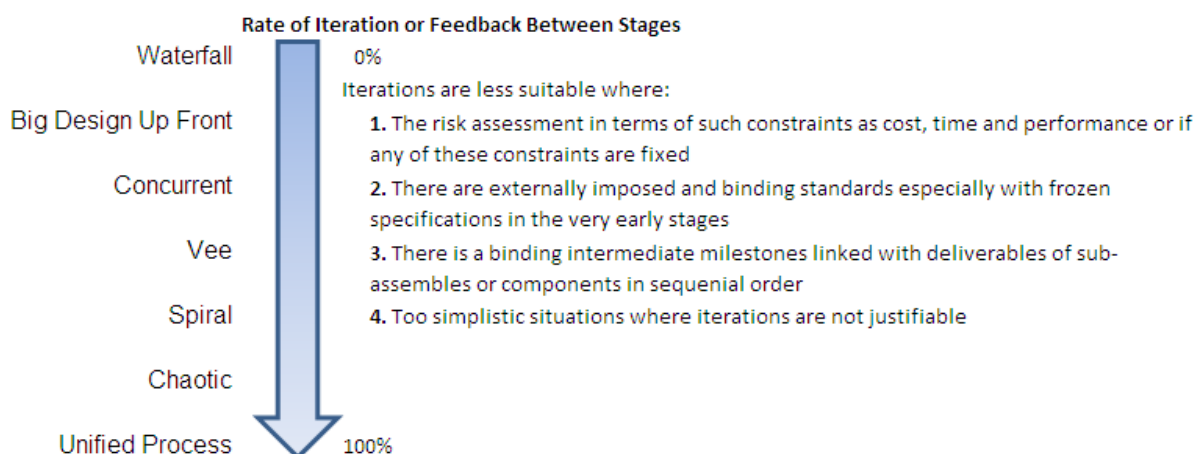

Figure 53: Product Development Lifecycles

The lifecycles impress a grouping and organisation of the designer's toolkit upon the PDG hereby referred to as the conceptual framework (Figure 54); consequently, the following observations can be made:

1. The most basic waterfall lifecycle, when based on the PDG, would have the same number of stages as there are the number of techniques in the designer's toolkit;
2. The big design up-front and the concurrent lifecycle approaches would improve upon the waterfall lifecycle by introducing an arrangement for an early implementation of a group of techniques which have fewer implications to constraints thereby shortening the lifecycle. It is worth noting that the design principles are executed starting from the first one to the twelfth; the distinction between each design principle or rule to the next is in accordance with the domain mapping theory proposed by Suh (1990). Two main groupings of techniques were identified: product design drivers and product realisation. The product design drivers may be specifically documented as product design specifications and are sub-divided in to two, using terminology suggested by Foster (1986):
 - 2.1. Product design drivers are any fixed decisions or high level user benefits and constraints which are not likely to change that have to be made in the beginning stages of the design process and becomes fundamental determiners of all decisions that follow (Otto and Wood, 2001). The product design drivers provide the necessary input since "not all design knowledge is ever available a-priori." (Madhusudan, 2005). The design drivers could be assessed in terms technological yield, technological productivity and technological returns (Figure 54)
 - 2.1.1. Technological productivity is the amount of engineering effort spent to design a product taking advantage of difference between its performance and maximum possible permitted by natural laws;
 - 2.1.2. Technological yield is the competitive intensity of the (engineering) industry to take advantage of the technological productivity i.e. the value of the design productivity; and
 - 2.1.3. Technological returns are the collective contribution of the technological productivity and its technological yield.
 - 2.2. Product realisation refers to the transformation of the product design specifications into realised product concepts (Thoben et. al, 2001).
3. The 'vee' lifecycle introduces mandatory verification and validation through iteration. The conceptual framework requires sequential implementation of two 'vee' lifecycles signified by the location of the convergent techniques. In the implementation of the first 'vee' lifecycle, the technological yield would be verified and validated by the technological productivity. The implementation of the second 'vee' lifecycle is entirely within the product realisation activities. Again it is worth noting that the 'vee' lifecycle introduces the zigzagging nature of implementing a convergent technique followed by a divergent technique as stipulated by Suh (1995).

- The spiral lifecycle breaks down the product into sub-assemblies or major components and applies the entire conceptual framework with the two successive 'vee' lifecycle approaches completely for every sub-assembly or major component in a step-wise priority. The implementation of the spiral lifecycle would be such that priorities would result in a major component that is going into a sub-assembly which would grow until it eventually becomes a product.
- Chaotic lifecycle refers to no pre-ordering of the stages but it improves the spiral lifecycle by shortening the incremental product developments. The rule is that incremental developments of the product would depend on the decisions made at the end of earlier stages before the next increment developmental stage i.e. the shorter the rate of incremental developments, the more the possibility of taking any direction to enrich the product – this is a distinct feature of the chaotic lifecycle (Figure 54); and

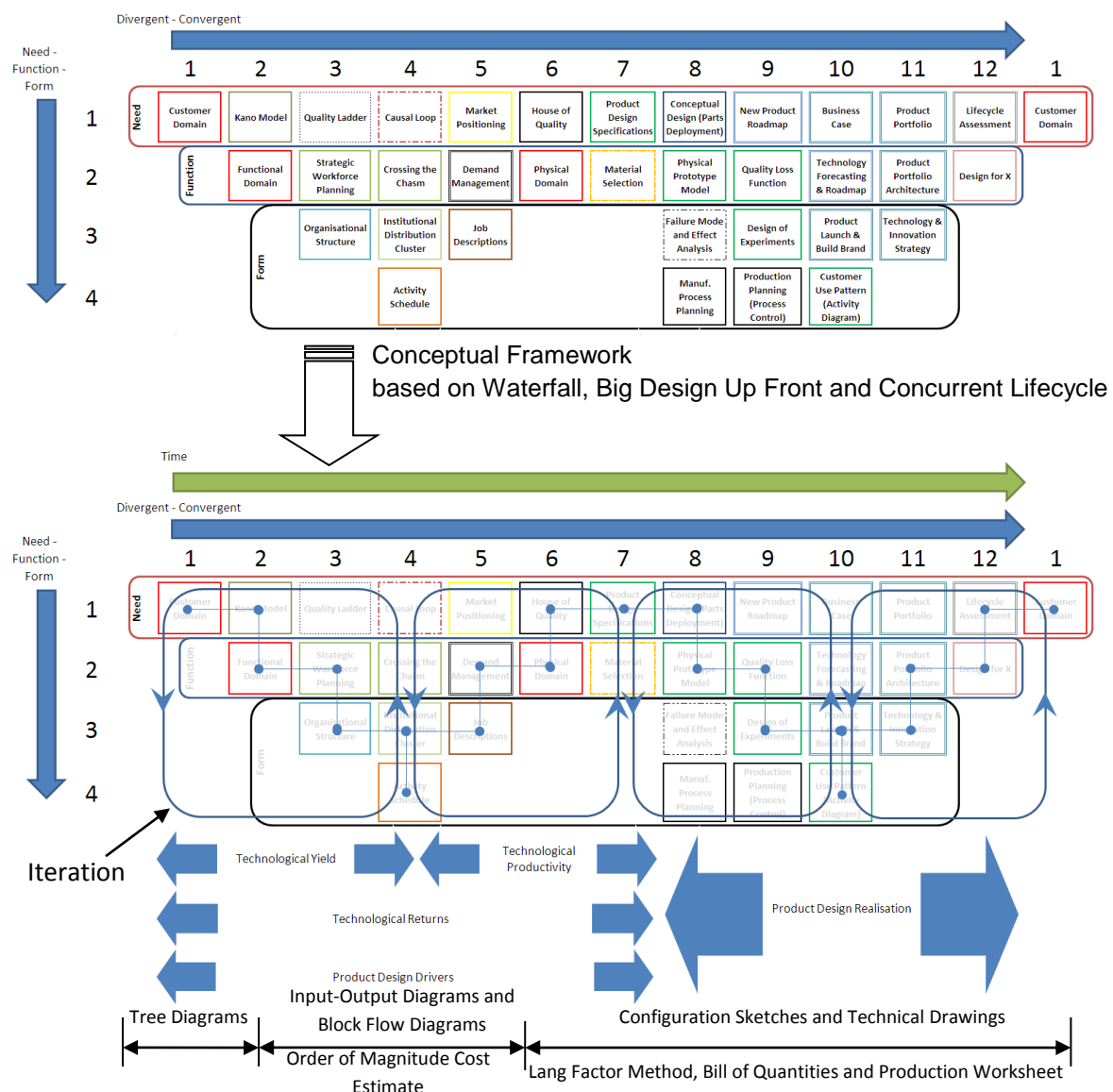

Figure 54: Conceptual Framework emphasising the Vee, Spiral Unified Process Lifecycle (Note the Introduction of the Iteration, the Change in the Complexity of Accompanying Design Mapping Models and the Cost Estimation Documentation)

6. Unified process lifecycle refers to improving the chaotic lifecycle by including a rework strategy into the incremental developments; hence, the capability to customise the choice of which lifecycle to implement – the lifecycle is not pre-selected.

4.3.2 Product Design Method Notation

In this research, any product design method may be defined as a description of the locations of a subset of the designer’s toolkit in the conceptual framework. The underlying principle is that any product design methodology must incorporate at least four techniques from the conceptual framework: one technique from each of the need-function-form structure regardless of its status on the divergent-convergent structure; hence, a need-function-form notation can be used to describe any product design methodology to truncate the graphical description of the designer’s toolkit through the conceptual framework. The symbols used are:

- ‘Need’ is represented by N_d ;
- ‘Function’ is represented by F_n ; and
- ‘Form’ is represented by F_m . Because the ‘Form’ dimension is bisected, a superscript of ‘T’ and ‘S’ would be used to indicate the intended technique.
 - Form Tactical (F_{m_T}): These are techniques applied by teams of design professionals within the premises of the organisation where they work; and
 - Form Strategic (F_{m_S}): These are techniques applied by teams of design professionals outside the premises or in conjunction with human resource inputs coming from outside the organisation where they work.

The designers should be trained and allowed to develop these descriptions to build customisable product design methods suitable for their objectives or business.

For example, the notation for a design process similar to robust design is (Expression 6):

$$N_e^{7-8} F_n^{8-9} F_{m_T}^9 F_{m_S}^{10}$$

Expression 6: Design Notation of the Product Design Method similar to Robust Design

By blanking the other techniques in the overall conceptual framework, such a methodology may be illustrated (Figure 55).

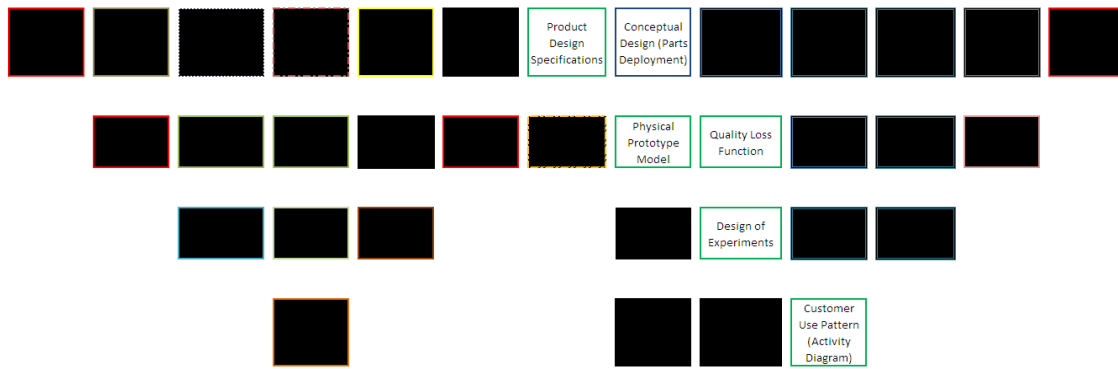

Figure 55: Conceptual Framework for a Methodology similar to Robust Design

Figure 54 also shows the change in the complexity of the drawings accompanying the techniques or activities in the conceptual framework and the associated possible formulae and records necessary for use to show concerns for cost considerations (Section 3.3). They increase in accuracy from Design Principle or Rule 1 to the Design Principle or Rule 12.

Figure 54 shows the case where there is a single iteration for the technological yield and technological productivity and two iterations for product design realization. It is possible to increase the number of iterations for each of these groupings of techniques; this means dividing the grouping of techniques into the same number as the intended iterations. One iteration means executing all the need activities as a single step, then all function activities as a single step and finally all the form activities as a single step. Two iterations means executing the each need-function-form twice before moving to the following design principle or rule (Figure 56). Hence the product design method notation may be appended to reflect the number of iterations using brackets, for example Expression 7 shows that there is no iteration for the technological yield, in fact it is not done, and a single iteration for the technological productivity and two iterations for the product realization:

$$Ne^{7-8}Fn^{8-9}Fm_T^9Fm_S^{10} \langle 0|1|2 \rangle$$

Expression 7: Design Notation showing the Number of Iterations



Figure 56: Conceptual Framework for a Methodology similar to Robust Design with specified Iterations

5.3.3 Configuration Scheme

In this research, a group of products that share the same human and non-human resources in an institution is referred to as a project; a programme is a group of projects that share a common pool of institutions; and a policy is implemented through a group of programmes. The following configuration scheme is adopted to provide the link between policies, programmes, projects and products (Expression 8):

*Policy – Programme – Product Design Method Template – Project – Product – SubAssemblies
– Components*

Expression 8: General Root of the Configuration Scheme

In an area where project resourcing is through policies, the advantages of this configuration scheme are enormous. The configuration scheme is also useful for naming product design methods (Section 6.2.2).

5.4 Summary of the Principles of the Product Design Guidelines

The product design guidelines were developed by encompassing the established design methods and theory from countries in the northern hemisphere and these were placed within a conceptual framework which relates the design process to organisational and political infrastructure of a country.

The research findings demonstrate that product design methods have the following five key characteristics:

1. The divergent – convergent structure;
2. The need – function – form structure;
3. The product development lifecycles
4. The product design drivers; and
5. The product realisation process

The divergent – convergent structure leads to formulation of twelve design rules; whilst the need – function – form structure establishes three types of attributes. Techniques that are used in product design operate the twelve rules to manipulate the three types of attributes. Based on the types of attributes involved, a technique may be referred to as divergent or convergent.

Based on these characteristics, the possibility to develop the product design guidelines was explored. The product design guidelines formulated in this research are comprised of:

1. Conceptual Framework;
2. Product Design Method Notation; and
3. Configuration Scheme

The product development lifecycle directs the workflow for operating the activities through the techniques specified in the conceptual framework. The following types of lifecycle were identified as being important to the practice of product design:

1. Waterfall Lifecycle which organises all of the design activities in a serial sequence;
2. Concurrent Lifecycle which organises some or all of the design activities in parallel to shorten implementation time associated with, and hence improve, the waterfall lifecycle;
3. Big Design Up-Front Lifecycle which prioritizes, through careful employment of the concurrent lifecycle, the design activities that are less costly or risky at the expense of those that are more costly or risky;
4. Vee Lifecycle introduces verification and validation through iterations into the waterfall, concurrent or big design up-front lifecycles. This is achieved through executing activities associated with divergent techniques in between any two convergent technique;
5. Spiral Lifecycle associates the iterations with releases of sub-assemblies with each iteration executing all techniques of the product design method;
6. Chaotic Lifecycle enhances the spiral lifecycle by delaying eliminating pre - planning of the iterations so that decision on which technique to perform are made at the end of each iteration ; and
7. Unified Lifecycle introduces a second lifecycle i.e. it is two dimensional. The waterfall lifecycle is executed in full in one of the dimensions; the other dimension schedules the iterations as well as the workloads.

The product design method notation assists in quick selection and communication of techniques in the conceptual framework. It assumes the conceptual frameworks to be Cartesian co - ordinate system; two co – ordinates are used to specify the location of the techniques. One co - ordinate specify the location along an axis defined by the need – function – form structure; the other co – ordinate specifies location along the divergent – convergent axis.

The configuration scheme helps the designer or design team to identify national policies, programmes, projects, sub-assemblies and components associated with the product they are about to design. This is critical for resource allocation.

5.5 Implementation of the Conceptual Framework and Product Design Guidelines

This section examines case study work conducted in Botswana to validate the product design guidelines (PDG) proposed by this research. Section 6.2 compares the PDG with the product design method used at the Rural Industries Promotions Company (Botswana) [RIPCO (B)]. Its product design method is documented as OP 7.3 Design and Development (RIPCO (B) Quality Office, 2008).

5.6 Overview of the Difference between the Product Design Guidelines proposed by this Research and the Product Design Method practised at RIPCO (B)

The PDG are intended for application by product designers whose business is to provide solutions to problems of the least economically developed countries (LDC). The PDG are comprised of three parts (Section 5.3):

1. The Conceptual Framework;
2. The Product Design Method Notation; and
3. The Configuration Scheme.

The PDG simplify the selection of appropriate product design method template (Section 4.4.1). The product design method templates comprise of methods already in the public domain that have been documented in peer reviewed literature. The selection of a suitable product design method could be achieved through the following four steps:

1. An assessment of the product design activities to be performed by the product design team for effectiveness;
2. The identification of effective national policies, programmes and projects related to the product that is to be designed;
3. The selection of an appropriate product design method template or techniques from the conceptual framework to formulate a unique product design procedure; and
4. The quantification of the required product design effort and resources.

5.6.1 Step 1: An Assessment of the Product Design Activities to be performed by Team of Design Professional(s) for Effectiveness

The conceptual framework is a network of design tables; a design table represents a unique management or engineering technique that is used to direct product design activities. The headings of the rows and the columns in a design table represent the attributes; the design principle or rule is the manner of manipulating these attributes to enable extraction of meaningful information. There are twelve design principles or rules and three types of attributes associated with the conceptual framework. The

structured layout of the design principles or rules and the attribute results in the conceptual framework.

The conceptual framework is divided into the following two stages which may be depicted at its base (Figure 57 and Section 5.3.1):

1. Product design drivers: These are comprised of techniques which have advantages such as being less risky, cost effective and less time consuming. These techniques are classified as:
 - a. Technological Yield; and
 - b. Technological Productivity.
2. Product realisation activities: These are comprised of techniques involving physical embodiments that consume material and energy. These techniques tend to be very costly, mostly time consuming and highly risky.

All of the products designed at RIPCO (B) and included in this research programme were at the product realisation stage; hence, the needs of the team of product design engineers were assessed for that stage. They were required to generate five physical prototypes:

1. A food grain planting prototype referred to as an agricultural planter;
2. Three food grain primary processing prototypes:
 - a. The maize dryer;
 - b. The sorghum milling plant; and
 - c. The *morama* cracker.
3. An energy generation and utilisation prototype referred to as a streetlight prototype.

If it is assessed that the needs of the design team require the execution of the product design drivers, then, the procedure review committee regulations stipulated in the RIPCO (B) ISO 9000: 2000 Quality manual Documentation requires them to select a product design method template that would enable the achievement of such a need or generate a unique product design procedure. This would mean deferring product realisation activities.

The conceptual framework may be visualised as having twelve vertical columns and four horizontal rows (Figure 57). The horizontal rows are four as informed by lifecycles, in particular the vee lifecycle (Section 5.3.1). The sequence of design activities on the implementation of the entire vertical design principle or rule will involve a convergent technique and several divergent activities – because there is only one convergent technique associated with any design rule i.e. such a convergent technique is always sandwiched by divergent techniques. The first seven of the twelve design rules are associated with the product design drivers whilst the last five are associated with the product realisation process. The recommended implementation of the design rules is step-wise from Design Rule 1 to 12; executing a design rule requires concurrent implementation of all design tables which have

been selected from within the respective vertical column – this is referred to as vertical design rule level implementation (VD/RLI) as shown in Figure 57. Alternatively, the horizontal attribute level implementation (HALI) may be executed where all the techniques associated with an attribute type are executed concurrently – this would result in a waterfall lifecycle.

All of management and engineering techniques which are part of product design methods studied in this research have been incorporated as design tables in the conceptual framework; the conceptual framework may be proposed as enabling a well designed product. It is assumed that any product design method that deals adequately with all design rules of the conceptual framework that enable the product designers to be effective would offer a superior solution.

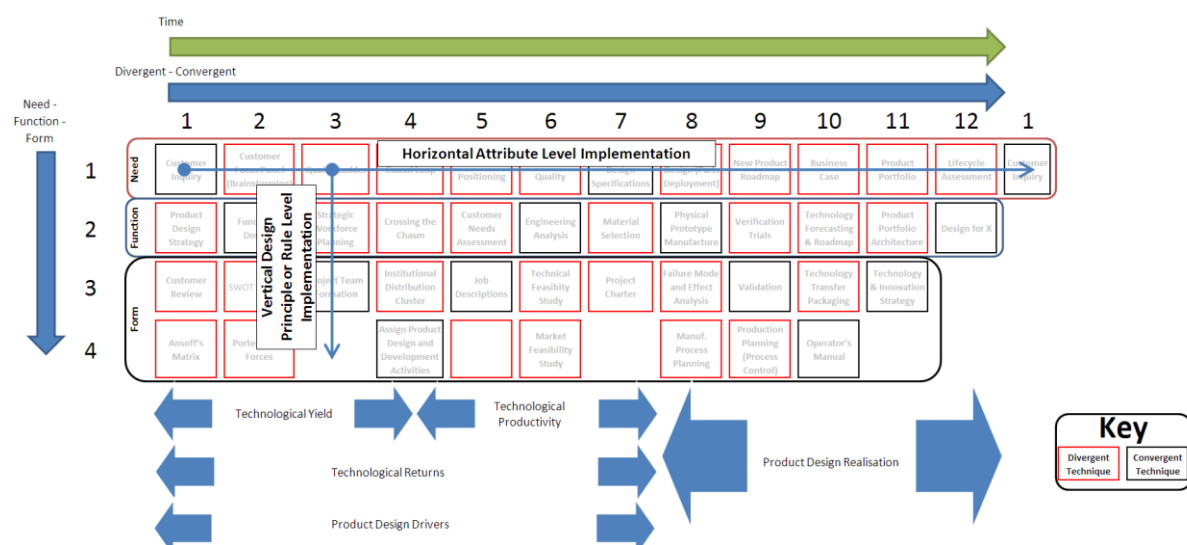

Figure 57: Attribute and Design Rule Implementation

Chapter 5 gives a more elaborate discussion of the principles of the proposed product design guidelines. But in short, the team of design professionals must establish their needs regarding the following:

1. The extent to which the design effort must include product design drivers activities and product realisation process activities; and
2. The number of product design reviews to hold during the implementation of the product design method template or procedure as chosen or formulated.

5.6.2 Step 2: The Identification of any Effective National Policy, Programme, Project and Stakeholders

Intermediate technology (ITech) is new technology intended to address the basic needs of the LEDC (Schumacher, 1973). Products are one such technology. In this research, a group of products that share the same human and non-human resources in an institution is referred to as a project and a programme is a group of projects

that share a common pool of institutions; a policy is comprised of a battery of programmes.

Based on the basic needs of the LEDC and as exemplified by Whitby (1985), this research categorizes ITech according to the following six programmes:

1. Building and Construction Materials Processing Programme (B&CMP – ITech);
2. Citizen Employment and Empowerment Programme (CE&E – ITech);
3. Energy Generation and Utilisation Programme (EG&U – ITech);
4. Grain/Food Production and Processing Programme (G/FP&P – ITech);
5. Transport Programme (T – ITech);
6. Water and Sanitation Programme (W&S – ITech)

The implementation of any ITech programme must identify all of its projects and products. Of necessity, the product design specifications of such projects and products should be synchronised within the programme.

The G/FP&P – ITech programme (Figure 58) dominated the product design activities at the Product Design Office in RIPCO (B) during the three year study period from January 2008 to December 2010. The G/FP&P – ITech programme is concerned with designing products for grain or food production and processing. Eleven grain/food products which can be grouped as projects for particular grain varieties from literature (Bainer et. al, 1955; Shippen et. al., 1966a; Shippen et. al., 1966b; Howard, 1970); at the Product Design Office, three projects were undertaken: maize grain project of which the maize dryer is a product under the spot light, *morama* grain project of which *morama* cracker is a product being designed and sorghum grain project of which the dehuller and hammermill products were undergoing continuous improvements (Figure 58 and Figure 59).

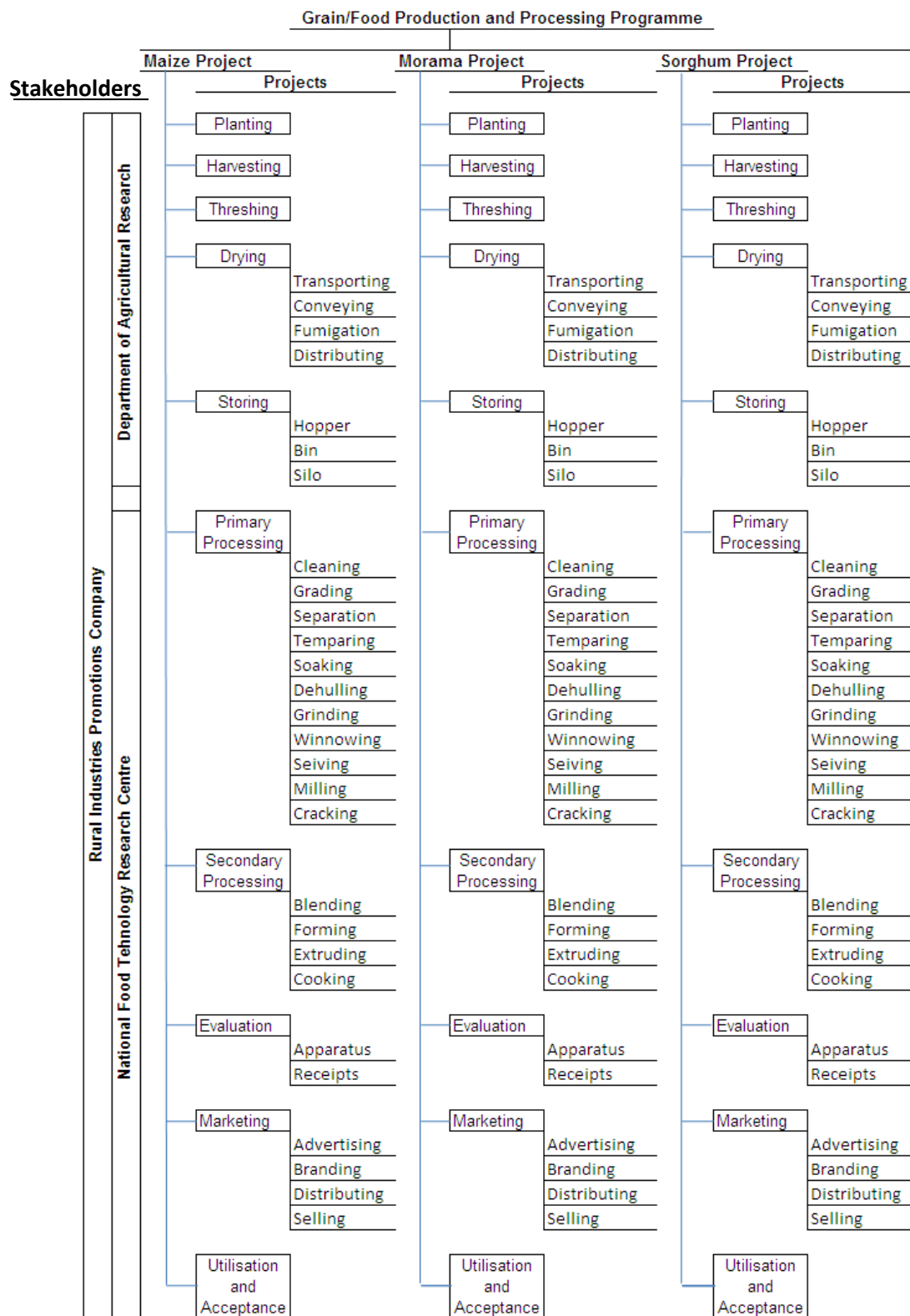

Figure 58: The G/FP&P - ITech Programme, Projects, Products and Stakeholders

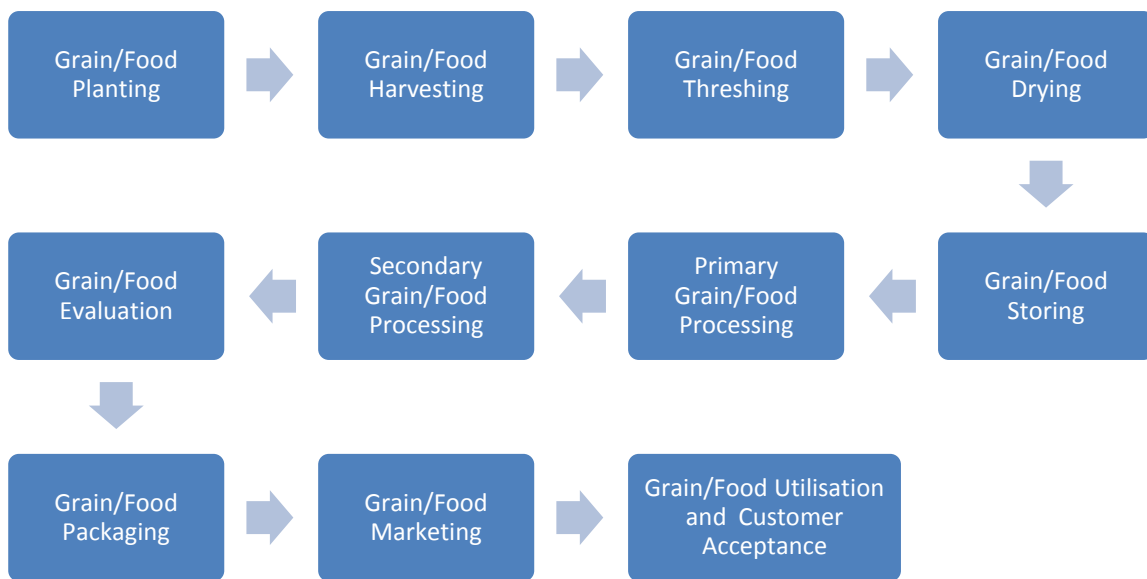

Figure 59: The Eleven Products that constitute the G/FP&P-ITech Project

The EG&U – ITech is the dominant programme for the Energy Section in RIPCO (B); the proposed product design guidelines were used on a product to design the streetlight product and the poultry heating product both of which involved mechanical engineers from the Energy Section.

The B&CMP – ITech (Figure 60) is the dominant programme for the Civil Section in RIPCO (B); during the study period, on-going product design activities involving civil engineers were:

- a. Forming and cutting product to generate building brick making physical prototype; and
- b. Size reduction product to generate construction rubble hammer-mill physical prototype.

Design effort from the researcher on the EG&U – ITech and B&CMP – ITech programmes was scarcely applied at RIPCO (B) and no design reviews were held for these projects.

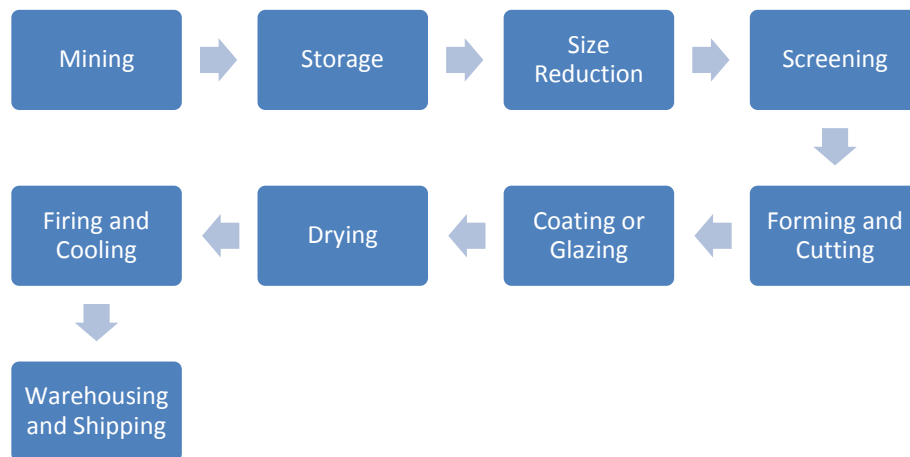

Figure 60: The Nine products that constitute the B&CM-ITech Project

In total, the proposed product design guidelines were used to undertake three projects. Traditionally, these projects were executed by RIPCO (B), through memoranda of agreement with Department of Agricultural Research (DAR), National Food Technology Research Centre (NFTRC) and University of Botswana (UB).

This case study will concentrate only on the G/FP&P – ITech programme (Figure 58 and Figure 59). In Botswana, the G/FP&P – ITech Programme is associated with the Integrated Support Programme for Arable Agricultural Development (ISPAAD). This research proposes to make ISPAAD operational through the Young Farmers Fund (YFF) which is a CE&E – ITech programme (Section 6.3.1.1). ISPAAD is administered by the Ministry of Agriculture whilst YFF is administered by the Citizen Empowerment and Entrepreneurial Agency (CEDA), which is an arm of the Ministry of Finance and Development Planning (MFDP). Funding and priorities for these programmes are provided through five year national development plans (NDP); for the period 2009 – 2014, the priorities of these programmes are set by NDP 10. These two programmes will therefore provide the needs from which products will be designed as industrial case applications.

In summary, the team of product design professionals must identify national programmes that affect the product area of their concern and they must engage with the other operational stakeholders during the implementation of their product design method. Although not specifically covered in this sub-section, the national policies pertaining to such issues as intellectual property must also be identified and adhered to as required by the Design Principle or Rule 1 (Section 6.3.1).

5.6.3 Step 3: The Selection of the Appropriate Product Design Method Template or Formulation of a unique Product Design Procedure

The management and engineering objectives at RIPCO (B), as documented in its quality policy, require strict adherence to OP 7.3 Design and Development (RIPCO (B) Quality Office, 2008); hence, the product design method was pre-selected for the case study work.

All of the design tables associated with the selected product design method should be described using the product design method notation and/or graphical representation and be assigned a unique given-name using a configuration scheme, (Section 5.3.2 and Section 5.3.3), a brief description to reflect the intended purpose as well as the storage location for the information generated with appropriate access restrictions for the design team and a verification of design teams knowledge with respect to the product design method. All resources used must be genuine.

The general root of the configuration scheme (Expression 8) is simplified to the following root to name product design methods by excluding policies (Expression 9):

*Programme – Product Design Method Template – Project – Product – SubAssemblies
– Components*

Expression 9: Root to Name Product Design Methods

Using Expression 9, the product design method for this case study may be expressed as (Expression 10):

ISPAAD.YFF – RIPC0 (B)

Expression 10: Root of the Case Application Product Design Method

Expression 11 shows the RIPC0 (B) product design method (Figure 61) which was selected for this case industrial applications and has the following notation [this is inline with the ISO 9000:2000 Quality Management Documentation enforced at RIPC0 (B)]:

$$Ne^{1-2-7-8}Fn^{8-9}Fm_T^{2-6-7-8-9}Fm_S^{2-6-10}$$

Expression 11: Design Notation of the RIPC0 (B) Product Design Method

As stated earlier, the product design engineers were required to generate four physical prototypes related to ISPAAD and YFF:

1. The food grain planting prototype (Expression 12),

ISPAAD.YFF – RIPC0 (B) – Sorghum – Planting

Expression 12: Sorghum Planting Case Application Product Name

2. The food grain primary processing prototypes (Expressions 13, 14 and 15):
 - a. Maize Dryer

ISPAAD.YFF – RIPC0 (B) – Maize – Dryer

Expression 13: Maize Dryer Case Application Product Name

- b. Sorghum Milling Plant

ISPAAD.YFF – RIPC0 (B) – Sorghum – Milling

Expression 14: Sorghum Milling Plant Case Application Product Name

A plant is a group of physical prototypes, typical of one-off turnkey products that are installed to meet the design needs.

c. *Morama* Cracker

ISPAAD – RIPCO (B) – *Morama* – Cracker

Expression 15: *Morama* Milling Plant Case Application Product Name

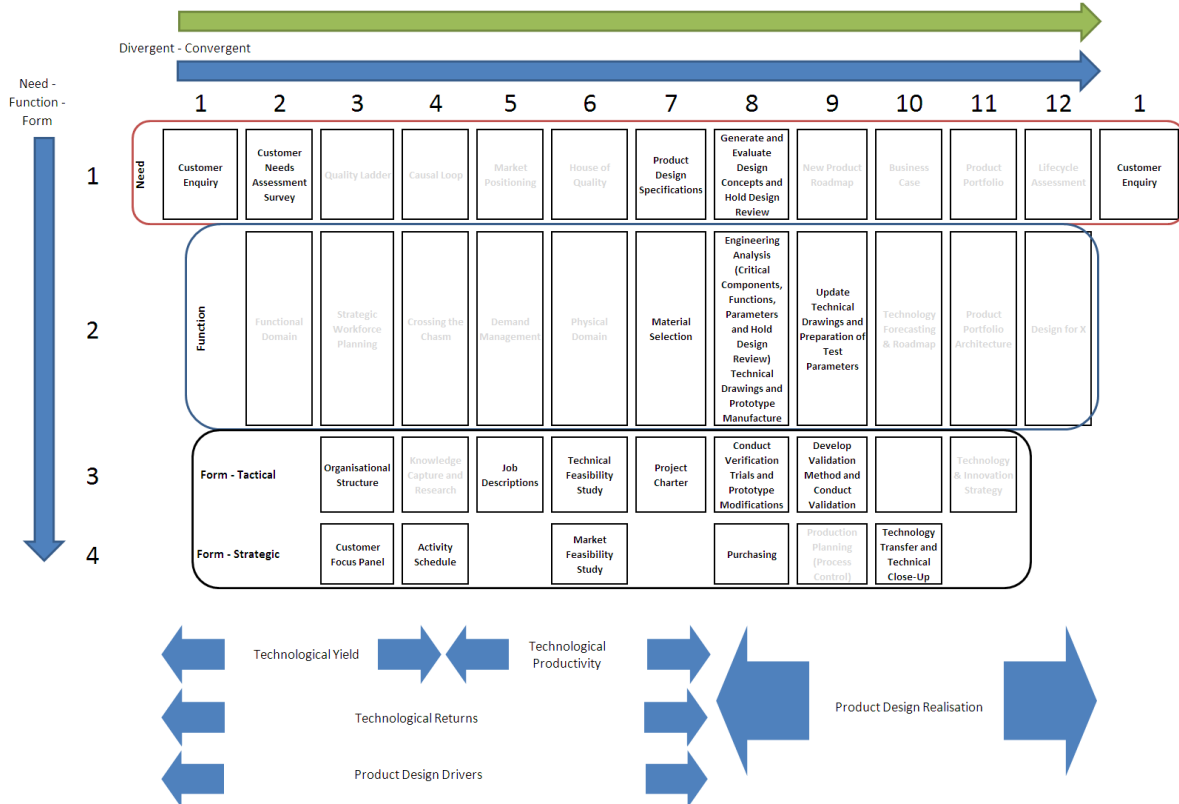

Figure 61: Product Design Method practiced at RIPCO(B) [adapted from ISO 9000: 2000 Quality System Documentation Manual for RIPCO(B)]

From Expression 11, the RIPCO (B) product design method may be sub-divided as follows (Expressions 16, 17 and 18):

1. Product Design Drivers:
 - a. Technological Yield:

$$Ne^{1-2}Fm_T^2Fm_S^{21}$$

Expression 16: Technological Yield

- b. Technological Productivity:

$$Ne^7Fm_T^{6-7}Fm_S^6$$

Expression 17: Technological Productivity

2. Product Realisation:

$$Ne^8Fn^{8-9}Fm_T^{8-9}Fm_S^{10}$$

Expression 18: Product Realisation

The information related to these projects should be stored in a computer with a directory identical to the programme name (Expression 12, 13, 14 and 15).

Iterations are introduced into groupings of design tables (Section 5.3.2); these iterative technique groupings are used to sub-divide the product design drivers and the product realisation process stages. The number of iterations per stage must be established and agreed upon by the team of design professionals. A design review to herald a semi-complete product release must be held at the end of each iterative technique grouping. The design review also provides an opportunity to audit the product design activities that would have been implemented and to plan those still to be implemented.

In summary, the product design method for use by the design team must be determined or which design tables to include in formulating a unique product design procedure that accurately meets the requirements at hand.

5.6.4 Step 4: Quantify the required Design Effort and Resources.

The product design team should implement the chosen product design method template or procedure and generate reports to document the outputs from their activities. These reports must be of a format that is easily recognisable and tied to the product development lifecycle of the selected product design method template.

The physical prototype models and the manufacturing process planning of the maize dryer and *morama* cracker industrial case application, were already done by the time when research attention was given; the quality loss function was being determined through verification trials. The verification trials were not successful therefore the prototypes were underperforming. To address this situation, an examination of the techniques which were applied prior to the quality loss function according to Expression 11 was necessary.

5.6.5 Shortcomings of Existing RIPCO(B) Design Methods

These problems identified some short comings from the RIPCO (B) product design method. The method is a classic example of design activities which are performed without successive step-wise execution of design principles or rules as proposed by the PDG:

1. The quality loss function or verification trials (Fn^9) are correctly performed after the physical prototype model (Fn^8);

2. The physical prototype model (Fp^{θ}), a convergent technique, is correctly performed after the concept generation, development and selection (Ne^{θ}), a divergent technique, which correctly follows both the product design specifications (Ne^{γ}) and the customer domain or customer request (Ne^{λ}) – both of which are convergent technique on the horizontal need attribute level;
3. No failure mode and effect analysis ($Fm_{T^{\theta}}$) is done before prototype manufacturing process planning (Fms^{θ}) as indicated by Expression 11 and Figure 60;
4. Normally, customer requests are handled with selective front-end techniques; the customer review ($Fm_{T^{\lambda}}$) is done but the Kano model or parametric analysis (Ne^2) as well as horizontal form-tactical attribute level design activities ($Fm_{T^{2-3-4-5-6-7}}$) that are structured for a product are never done although this is correctly procedural as per the OP 7.3 Design and Development (RIPCO (B) Quality Office, 2008);
5. The customer review ($Fm_{T^{\lambda}}$) is conducted with the assistance of a checklist, but it does not spell out the required horizontal form-tactical attributes;
6. Most of the form-tactical attributes are never used at operations level; the customer review technique requires the allocation of customer domain outputs by the marketing officer to a relevant arm of RIPCO (B). This is obviously best achieved through knowledge of the organisational structure (Fm_{T^3}) which is also useful to constitute product design teams and the operational activity schedule.
7. None of the horizontal function-attribute design activities that the product design drivers are ever used before the physical prototype model ($Fp^{1-2-3-4-5-6-7}$) were done as indicated by Expression 11 and Figure 61; and
8. All these concerns negatively affect the product design drivers; subsequently, the product design specifications and product realisation activities are inherently negatively affected resulting in reduced design capacity.

Chapter 6: Application of the Product Design Guidelines in Botswana

6.1 Introduction

The preceding chapters have described the development and principles of the product design guidelines (PDG). This chapter explains the ways in which the PDG were implemented and validated by using case studies in Botswana and the UK.

Section 6.2 provides a summary of the principles of the PDG developed in Chapter 5. Section 6.3 documents the design of products through the implementation of the PDG. The complexity of these products is similar to those usually designed and produced by RIPCO (B). Based on the national policies and programmes, these products are highly needed in Botswana. A critical evaluation of the PDG is provided in Section 6.4 to discuss the benefits and short comings which were experienced during the validation exercise. Lastly, Section 6.5 concludes this chapter with a summary.

6.2 Summary of the principles of the PDG

The product design methods have the following five key characteristics:

1. The divergent – convergent structure which lead to formulation of twelve design principles or rules;
2. The need – function – form structure through which three types of attributes were established;
3. The product development lifecycles
4. The product design drivers; and
5. The product realisation process

Based on the types of attributes involved, a technique may be referred to as divergent or convergent.

The product design guidelines were formulated and they are comprised of:

1. Conceptual Framework which, with the help of product development lifecycles, directs the workflow for operating the design activities;
2. Product Design Method Notation which assists in quick selection and communication of design activities based on the conceptual framework.; and
3. Configuration Scheme helps the designer or design team to identify national policies, programmes, projects, sub-assemblies and components associated with the product they are about to design and helps with resource allocation.

Within these case studies nine of the twelve design rules were tested.

6.3 Implementing the Product Design Guidelines by Modifying the RIPCO (B) Design Method

As per the findings of this study (Section 4.4.1), product design methods may have the following parts:

1. They may have a need-function-form structure which determines the attributes;
2. They may also have the divergent-convergent structure which determines the design principles or rules;
3. They may be controlled through product development lifecycles;
4. They could be sub-divided into product design drivers and the product realisation process activities.

All these would allow for the modification of product design method templates. The product design method templates are in the public domain, are known to work and should be taught in educational institutions; however, the case applications could not use the product design templates owing to the strict adherence to the ISO 9000: 2000 Quality System Documentation at RIPCO (B) which stipulates that all design work must be as specified in the OP 7.3 Design and Development.

Before any product design template can be altered or modified to suit the needs of the design team (Section 4.5), a pre-plan that incorporates the following precautions must be implemented: Product Design Template Back-Up, Inclusion or Omission of Design Tables and Attribute Alterations.

Product Design Method Template Back-Up: The first step in any modification exercise must be a back-up of the selected product design method template; this is particularly important if a product design method template is changed and it is later decided to reverse this decision.

Using the proposed design notation, all changes to a product design method template must be recorded including a description of the prompting circumstances. Such descriptions would be referred to as back-up records and should be defined through unique given-names that show a relation to the product being designed, which may include the date from when the changes were made and may be stored in the same place as other information related to the product. After it has been backed up, it could be modified.

Inclusion or Omission of Design Tables: The inclusion or omission of design tables that are not traditionally associated with the selected product design method template may affect the verification relationships between the design tables. Although inclusion of a design table translates into more work for the design professionals, omitting a design table has far more reaching implications than adding a design table. Inclusion or omission of design tables changes the underlying structure of the product design method template.

Attribute Alterations: Changes to attributes affect all of the different parts of a product design method. When changes are made to the attributes, no work should be on-going on any of the affected design tables. Once the changes have been made, they should be propagated to synchronise with the works on the affected design table; this maintains the quality of information for the product being designed.

These concerns regarding the RIPCO (B) product design method may be addressed through the inclusion of more techniques related to product design drivers through horizontal function-attribute design activities specifically to improve product design specifications and product realisation activities (Expression 19 and 20; Figure 62):

a. Technological Yield:

$$Ne^{1-2}Fn^{1-2-3-4}Fm_T^{1-3-4}Fm_S^{1-4}$$

Expression 19: Modified Technological Yield

b. Technological Productivity:

$$Ne^{6-7}Fn^{5-6-7}Fm_T^6Fm_S^{1-4}$$

Expression 20: Modified Technological Productivity

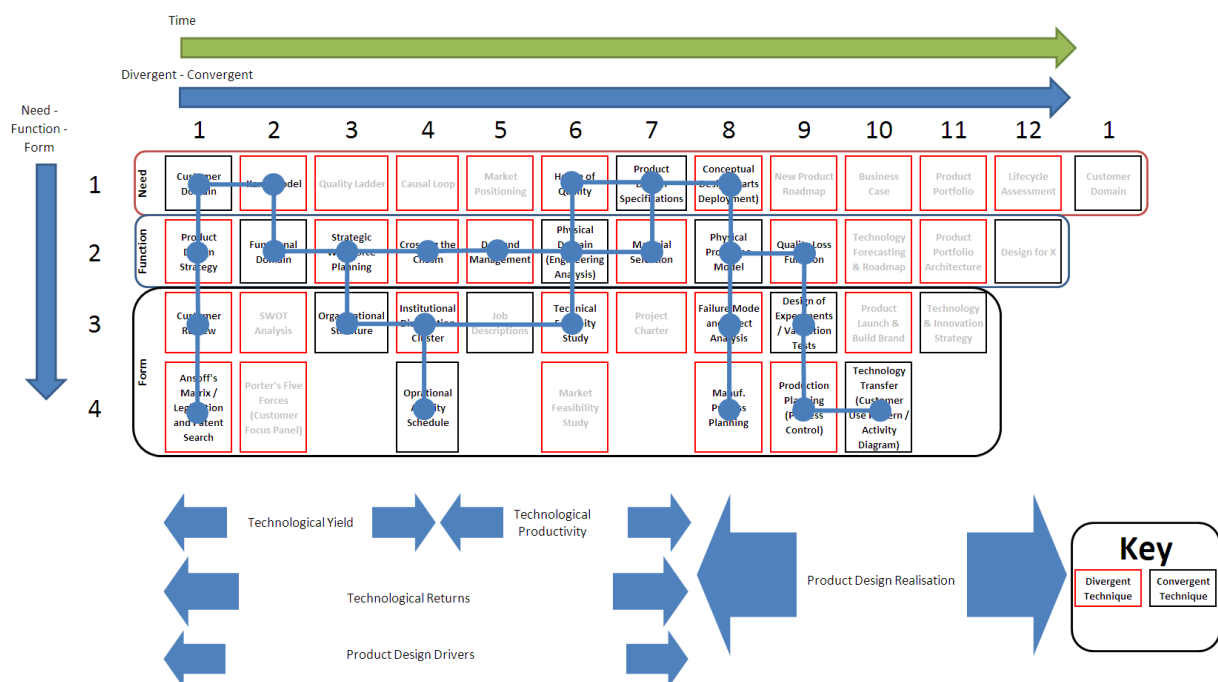

Figure 62: Modified Product Design Method Template

These modifications to the product design method used for the case study work allowed for the finalisation of the maize dryer within a three months period at RIPCO (B) from January to March 2009 (see Design Rule 9).

6.3.1 Determination of the Product Design Drivers

To simplify the determination of the product design drivers, the VD/RLI approach was used in this case study work as summarised in this sub-section.

Eight product design methods documented in literature contributed to the structure of the PDG. In this report, the representations used to report the inputs and outputs of the design tables may be general at the level of a programme or specific at the level of products or sub-functions depending on the intended benefit for clarity.

6.3.1.1 Technological Yield - Design Rules 1, 2, 3 and 4

The technological yield should then be determined; technological yield is a measure of the extent to which the technical potential is translated into actual technical performance; technical potential is the difference between the current technical performance and the technical performance limitations set by laws of nature. The amount of effort (including resources) invested to design a product taking advantage of the technical potential is referred to as the technological productivity accomplished through Design Principles or Rules 5, 6 and 7.

The technological yield is determined through the first four design principles or rules (Table 19); therefore, the choice of product design method template has a direct bearing on the determination of technological yield.

Rule Number	Rule or Principles
1	Establish and acquire knowledge of the true user needs (including views, buying habits, legislation, statutory regulations, intellectual property and official opinions) of the Customer relevant to the product area normally through structured customer interviews and customer questionnaires to ultimately produce a coherent statement of the question.
2	Market Gap Identification (Cross plots (for identification) of relationships and patterns between parameters which specify the purpose, design goals, functional requirements and functional transformations of various features of the product obtainable from desk research sources such as reports, proceedings, reference books and catalogues) to ultimately produce a coherent statement of the requirements to be met by a product/solution being designed
3	The range of qualities within a product, human resources able to undertake activities and communications structure required to meet the market gap
4	The graphical representation, or otherwise, of interrelationship between product performance variables, (the rate of diffusion of a technology through) market segments, geographic concentration of interconnected companies, businesses, suppliers, educational and other associated institutions in the product field and the human resource workflows of stepwise activities and action in a manner that supports simetime action and iterations.

Table 19: Technological Yield - Design Principles or Rules 1 – 4

6.3.1.1.1 Design Rule 1:

Product design starts by identifying and understanding the effects that are required from a product, commonly referred to as customer needs; however, in the absence of customers, the products must create their own market (Pugh, 1991). The workflow of product design could therefore stem from customer problems which are not currently solved by products or equally from product complaints; the give rise to two approaches of product design: One approach starts with an existing product in the market place and the other approach generates an entirely new product (Akao, 1990).

The products identified in the G/FP&P-ITech programme would benefit the technology development policies as spelled out in the National Policy on Agricultural

Development (Government of Botswana, 1991); this case study work focuses on the most recent of these:

1. The Integrated Support for Arable Agricultural Development (ISPAAD) replaced the Arable Land Development Programme (ALDEP) in 2008 as the main agricultural programme to address food security, mechanisation through technology adoption and general low productivity in the Botswana (Figure 7). However, ISPAAD prioritises food production.

The Arable Land Development Programme (ALDEP) was formulated and recognized for assisting small scale farmers to acquire farm investment packages (Auditor General, 2001). The programme was multi-staged both in terms of time as PILOT (1980 to 1981), ALDEP I (1982 to 1993) and ALDEP II (1996 to 2003) and in the provision of subsidized agricultural implements (Whiteside, 1997). These programmes would have lead to an increased donkey mechanisation by traditional farmers in the some parts of Botswana (Aganga and Tsopito, n.d.). Farm mechanisation developed as the design of double row tractor drawn planters was also designed at RIPCO (B) (Tagwa, 2005). This shows the link between products and programmes.

Using Expression 9, the product design method for the ISPAAD case applications is given by Expression 21:

ISPAAD – PDG

[Expression 21: Root of the ISPAAD Case Application Product Design Method](#)

2. Young Farmers Fund (YFF) was launched in 2006 to issue loans at lower interest rates with longer repayment period to the youth for use in commercial agriculture (Figure 63). YFF is directly related Citizen Employment and Empowerment Programme (CE&E – ITech) but is operational through the ISPAAD which is related to the Grain and Food Production and Processing (G/FP&P – ITech). YFF is administered by the Citizen Entrepreneurial Development Agency (CEDA). The YFF prioritises both food production and food processing.

Using Expression 9, the product design method for the YFF case applications is given by Expression 22:

YFF – PDG

[Expression 22: Root of the YFF Case Application Product Design Method](#)

and

3. Commercialisation through Small, Micro and Medium Enterprises (SMME) is supported by the Local Enterprise Authority (LEA) which was established by the Small Business Promotion Act, of 2003 (Sekwati, 2011). Unlike the

ISPAAD and YFF, LEA is not restricted to food production and processing but is concerned with SMME in general.

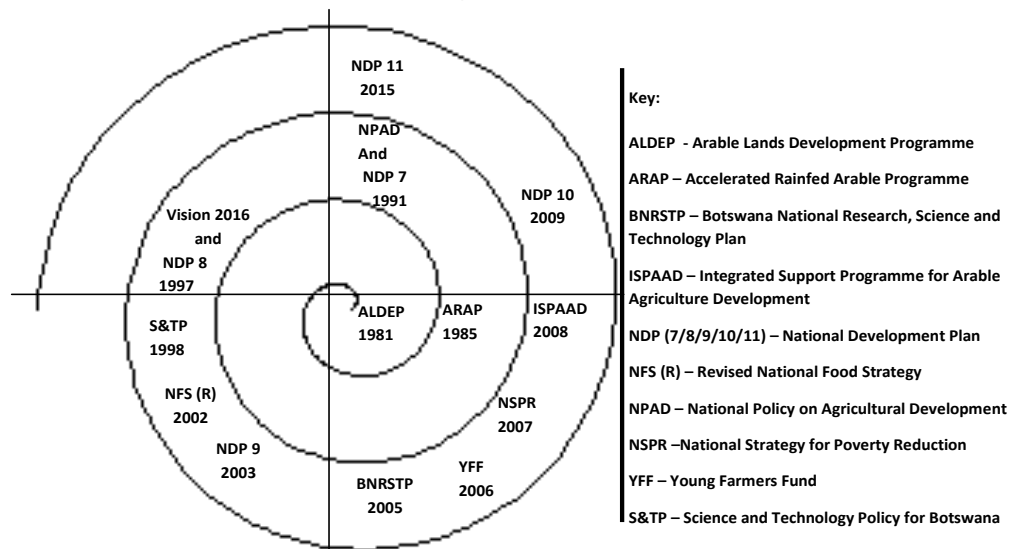

Figure 63: Design Principle or Rule 1: Customer Domain Information Sources - The Spiral Model Life Cycle of the Arable Agricultural Policy and Development Planning Programmes in Botswana

Livestock production is excluded because there was no product being designed for this agricultural sub-sector at RIPCO (B) – the Botswana Vision 2016 and the 1998 Science and Technology Policy were instrumental in the establishment of the Ministry of Infrastructure, Science and Technology in 2002 which developed the 2005 Botswana National Research, Science and Technology Plan and oversees the administrative control at RIPCO (B) and the Botswana Technology Centre (BoTeC).

These policies state the customer needs as objectives of the provision of food production and processing products (Figure 59 and 63). RIPCO (B) as an RSTI aims to facilitate the effective and efficient implementation of all these national policies. The objectives of ISPAAD, for example, were applied across all RIPCO (B) clients who wanted G/FP&P products; all of these clients were supported by government programmes on several development stages of their businesses. The PDG include the five product design lifecycle choices to positively structure and contribute to the product design activities targeted to these policies.

In this study, the technique that involves customer needs as attributes and uses Design Principle or Rule 1 is referred to as the customer domain. The most popular techniques for grouping similar customer needs and expectations are the affinity diagram and hierarchical cluster (Takai, 2005). Figure 64 shows a tree diagram which is a typical design mapping model for the customer domain (Section 3.3.2 and Section 5.3.1). Appendix 7 consolidates the customer domain of Figure 64 into a single need and expectation of the customer; this simplifies the presentation of the guidelines.

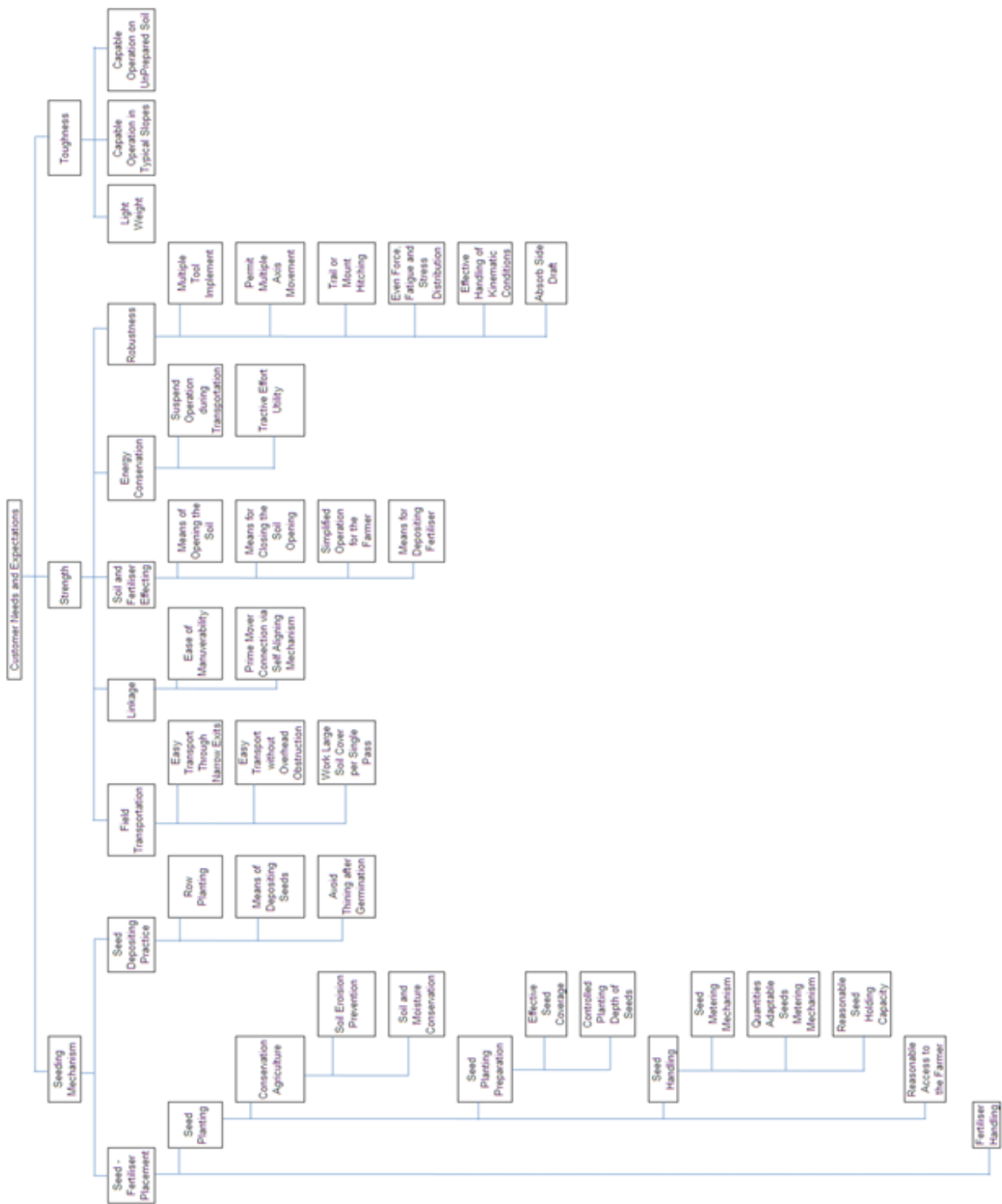

Figure 64: Customer Domain – ISPAAD and YFF Programmes (Planter Only)

One of the initial but stable decisions made by the design team is the selection of an overall product design strategy that is related to the effort required to address customer needs. There are four strategies to choose from:

1. Original Design;
2. Adaptive Design;
3. Variant Design; or
4. Craftsmanship.

Adaptive and variant designs are re-design strategies that require the product to have undergone original design while craftsmanship does not. Craftsmanship would have little or no benefit from the product design methods; it is important to note the difference between product design as well as research and development especially within the perspective of an LEDC.

Product design requires forecasting that may use models that rely on generally accepted scientific, engineering and management principles; on the other hand, technology research and development engages craftsmanship and trial and error activities to build knowledge which may be later incorporated as a scientific, engineering and management principle. Craftsmanship is therefore excluded for this case study work. In this study, the product design strategy is a technique that involves both the customer needs and the product functions as attributes and uses the Design Principle or Rule 1; this differentiates it from the Kano model.

The product design method as practiced at RIPCO (B) terminates with technology transfer where by a pre-production prototype referred to as a sample is packaged with production tooling (i.e. jig and fixtures) and documentations including bill of quantities, production process sheets and technology transfer certificate (Figure 61). A lot of emphasis is placed on finished physical embodiments of the pre-production prototype and the production tooling. Figure 65 shows the product design strategy approaches as applied to the ISPAAD and YFF physical pre-production prototypes and their production tooling. The product design strategy is to have a pre-production prototype that meets the customer needs at point of technology transfer. It should be noted that the technology transfer as practised at RIPCO (B) is part of the Design Principle or Rule 10 of the conceptual framework.

This case study work addresses one way by which the North-South Technology Transfer may be effected. The G/FP&P – ITech programme details out the products whose technology transfer may be of interest to Botswana from North America, Europe and Asia. Some of the product design methods from these geographical regions were examined in this study. This may be useful even for the achievement of the United Nations Millennium Goals.

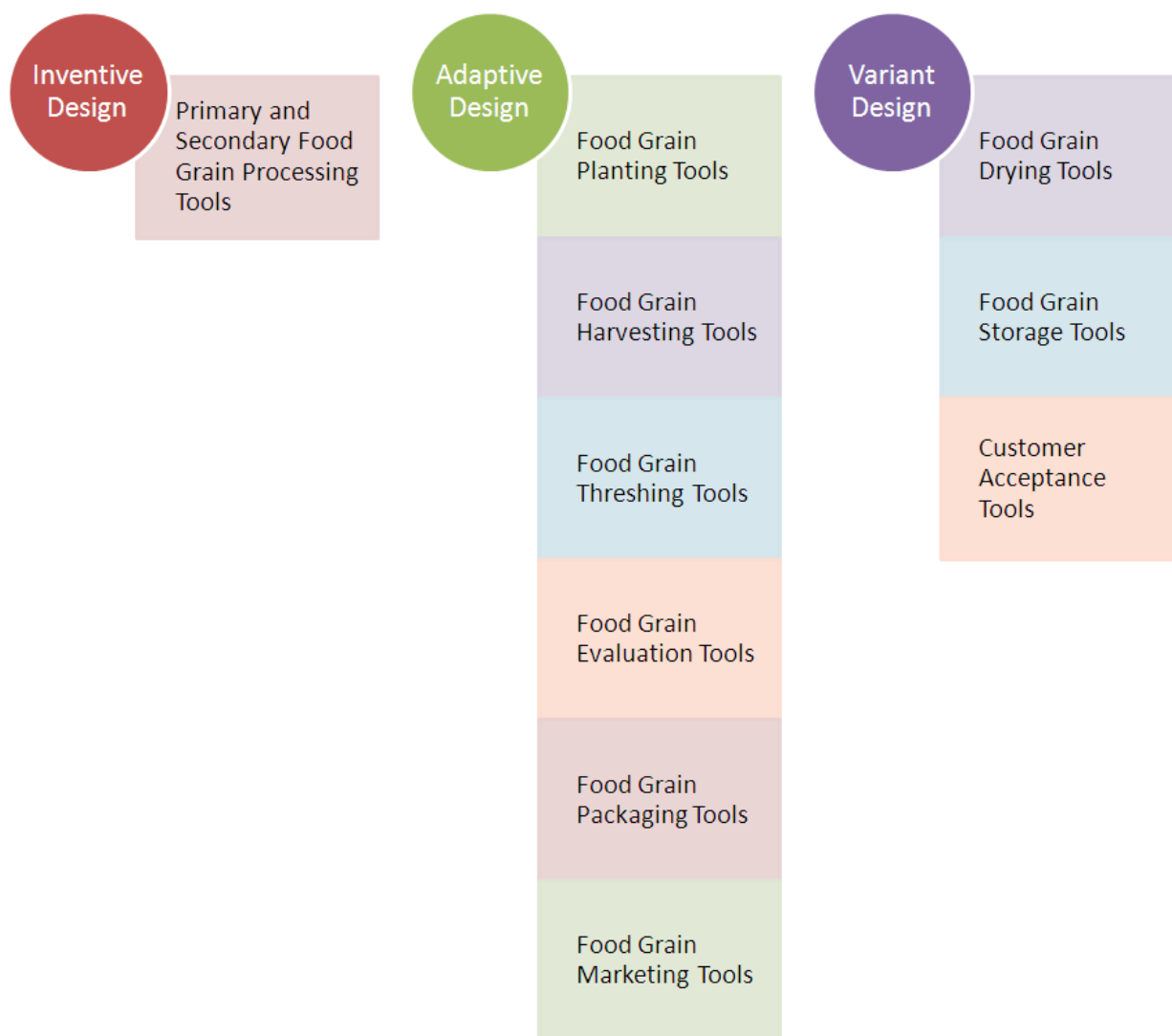

Figure 65: Product Design Strategy for the ISPAAD and YFF Programmes

As noted by Akao (1990), the product design workflow may be of two approaches: the design approach and the analytical approach:

- The design approach starts with the true user needs for a non-existing product such as the customer needs e.g. as specified national policy objectives that could only be addressed through inventive product design strategy.
- The analytical approach starts with the customer complaints from an existing product such as the customer review and reactions to intellectual property infringement assessments.

Customer review requires the application of the analytical approach type of product design as a first step under a control mechanism that avoids legal infringements. Intellectual property offers a legal and acceptable mechanism to protect inventive product design strategies whilst simultaneously causing technical advancement of

technologies. In this study, the customer review is a technique that involves the organisation of product design team i.e. its members and the customer needs using the Design Principle or Rule 1. Customer review is therefore a tactical management activity.

Intellectual property is granted by a government agency. Intellectual property protects new inventions, it gives the owner the right to prevent others from making, using, importing or selling the invention without permission. However, these rights are effective within a geographical area and only for limited time. According to the Intellectual Property Office in the United Kingdom, there are four types of intellectual property assets:

1. Patent protect new inventions in to the processes that make physical product embodiments to work;
2. Trademarks protect logos that distinguish physical product embodiments;
3. Design Rights protect the three dimensional shapes of physical product embodiments; and
4. Copyright protects recorded or written material.

Intellectual property offers value to products and are always legally contested. Patents, such as those offered by the United States Patent and Trademark Office (USPTO), have two main descriptive segments:

1. Background of the Invention (Table 20):
 - Field of the Invention; and
 - Description of Prior Art
2. Brief Description of the Drawings:
 - Description of the Preferred Embodiment: These are the specifications to provide a written description of the invention i.e. how the invention works and what it does as well as what it is made of and how it is made,; and
 - Summary of the Invention: These include the drawings and claims to define the extent of rights granted to the inventor by the intellectual property office and are used to determine the extent of possible infringement of others practicing the invention.

United States Patent No. 3680737 - 1 August 1972	
Types of Planters 1. High Speed Precision Planter 2. Pneumatic Planter: Selection of Seeds by Vacuum from an Ungraded Supply without Damaging the Seeds which is Discharged by Releasing the Vacuum	Planter Sub-Assemblies (from Drawings) as per US Pat. 3240175 - 15 March 1966 1. Seed Metering Mechanism 1.1 Rotatable Drum or Wheel 1.2 Projecting Fingers 1.3 Pick-Up Opening or Port 1.4 Source of Vacuum 1.5 Communication between the Pick-Up Opening and Source of Vacuum 2. Pump 3. Air Pressure Source to Discharge Seeds from Pick-Up Fingers as per US Pat. Application 836480 - 25 June 1969 1. Perforated Rotating Drum 1.1 Seed Supplied Internally to the Drum 1.2 Individual Seeds Held in Perforations by Air Pressure 1.3 Seed Released at a Discharge Location and Falls in a Discharge Tube and Carried by a Stream of Air to the Furrow
Specific Customer Needs Addressed 1. High Speed Planting Practice 2. Capacity for Seed Selection Accuracy from a Supply 3. Seed Depositing into a Furrow at Regular Intervals	
Addressed Disadvantage of Common Planters i.e. Prior State of the Art Common Planter Component 1 - Seed Plate 1. Celled Seed Plates that require Seeds that are Uniformly Graded 2. Necessity to Select from multiplicity of Seed Plates according to the Seed to be Planted 3. Seed Cells that remain Un-Filled at High Speeds resulting in Irregular Depositing of Seeds into the Furrow Common Planter Component 2 - Projecting Fingers 1. Frequent Seed Packing 2. Lack of Adherence to Vacuum Ported Fingers resulting in UnUniform Seed Discharge to the Furrow	
Constraints 1. Complicated 2. Expensive	
Types of Seeds 1. Corn	

Table 20: Patent Search on ISPAAD and YFF Programmes (focusing only on the planter and excluding the Illustration of Drawings)

Even without detailing the claims (Table 20), the background of the inventions illustrate product sub-assemblies which provides the design team with knowledge required to develop the solutions and also helps to establish the current product technical performance which is used to determine the technical potential.

The technical performance of products may be advanced through knowledge of other technology limiting factors other than intellectual property. The major technology limiting factors for the arable agriculture sub-sector in Botswana are (Government of Botswana, 1991):

1. Poor Soils and Un-Reliable Rainfall as well as general availability of Water;
2. Lack of, or Poor, Technology Management and Performance;
3. The Pricing Systems for Grains;
4. Unproductive, mostly Un-Skilled, Labour Force;
5. Lack of Diversification;
6. Non-Targeted use of Government Subsidies and Poorly Developed Physical Infrastructure; and
7. High Cost of Energy.

Product design that aims to advance technical performance towards these technology limits might lead to addressing the customer needs through intellectual property assets.

In applying the first design rule, the identified customer needs are useful to estimate the required design effort and enable intellectual property awareness in the product area; hence, the knowledge gained to start making educated guesses of the current technical performance and technology limits of the products under consideration based on the customer needs and their current potential solutions.

The strength of structured product design methods such as the PDG is that by following a well defined course of action, it is possible to rethink and rework with precision any product that may have been unknowingly designed and found to infringe intellectual property assets. The Design Principle or Rule 1 starts such a course of action.

For intellectual property and other national policies, programmes, projects as well as statutory acts search technique involves customer needs and market place regulations through the application of the Design Principle or Rule 1; hence, this technique is a strategic management activity.

6.3.1.1.2 Design Rule 2:

The Analytical Kano model continues the analysis of customer needs to subsequently derive the product functions and establish the relationship between product technical performance and customer satisfaction (Xu et.al., 2008); In this study, the Analytical Kano Model verifies the customer domain. It involves the following three major steps all of which were constantly implemented through informal interviews with RIPCO (B) customers whose business activities would benefit directly from ISPAAD and YFF:

1. Understanding of Customer Preferences: Customer surveys which may involve meetings at the customer's premises and verbally detailing out a pair of questions which includes a functional question and dysfunctional question; the functional question captures the customers' response if a product can satisfy a certain customer need whilst a dysfunctional question captures the customers' response if the product cannot satisfy that customer need. Each answer to these pair of questions is aligned with the Kano Evaluation Table and customer satisfaction quantified through Kano indices (Table 21). Any customer need that cannot be expressed as a function was considered to be a constraint which would be recorded as part of the Design Principle or Rule 7. Constraints are also central to the determination of the technical potential;
2. Establishment and Prioritising of Functional Requirements: Extracting information on an individual customer's perception of product functions (Table 21); and

Functions	Importance		Kano Indices					
	Satisfied Need	UnSatisfied Need	Cause	Effect	Satisfied Need Score	UnSatisfied Need Score	Angle (deg.)	Vector
Weigh Morama Beans	0	0.5	3	3	0	0.25	0	0
Remove Impurities	0	1	2	1	0	0.4	0	0
Receive Morama Beans	1	0.5	10	0	1	0.5	63	1
Convey Morama Beans	1	0	4	3	0.8	0	Infinity	1
Direct or Deliver Morama Beans	1	1	2	4	0.2	0.2	45	0
Store Morama Beans	0.5	0.5	4	3	0.4	0.4	45	1
Fumigate Morama Beans	0	0.5	4	3	0	0.4	0	0
Sort Morama Beans	0	0.5	2	1	0	0.2	0	0
Crack Morama Beans	1	1	4	1	0.9	0.9	45	1
Remove Crushed Shells as Impurities	1	1	1	3	0.1	0.1	45	0
Package Morama Kernels	0	0.5	0	10	0	0.05	0	0

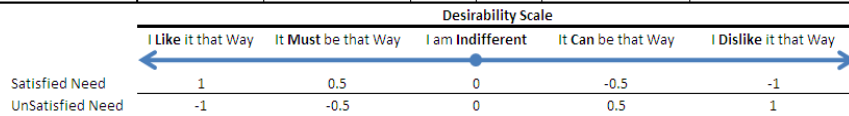

Table 21: Kano Evaluation Table for ISPAAD and YFF Programmes

3. Classification of Functional Requirements: Statistical determination of the final classification of a product function is made based on the analysis of the survey results of all respondent customers. The functional requirements are categorised through Kano classifiers which, in this study, is a line of 45° angle (Figure 66):

- Basic Needs/Functions which are expected by the customers and they lead to extreme customer dissatisfaction if they are absent or poorly satisfied,
- Competitive Needs/Functions are those for which better fulfillment leads to linear increment of customer satisfaction; and
- Delightful Needs/Functions are usually unexpected by the customers and can result in great satisfaction if they are available.

When compared with the Porter's Five Forces (Porter, 1991) for assessing industrial competitiveness (Figure 66):

- The basic needs/functions determine the cost of entry faced by a competitor into an industry;
- The competitive needs/functions affect the bargaining power of the suppliers and customers; and
- The delightful needs/functions contribute to product differentiation to deal with the threat of substitute product.

The closer the customer need or function is towards the origin of the cross plot, the more indifferent or less interested is the customer in the level of their performance. For example, the customers would be more delighted with storage fumigation products than weighing balances.

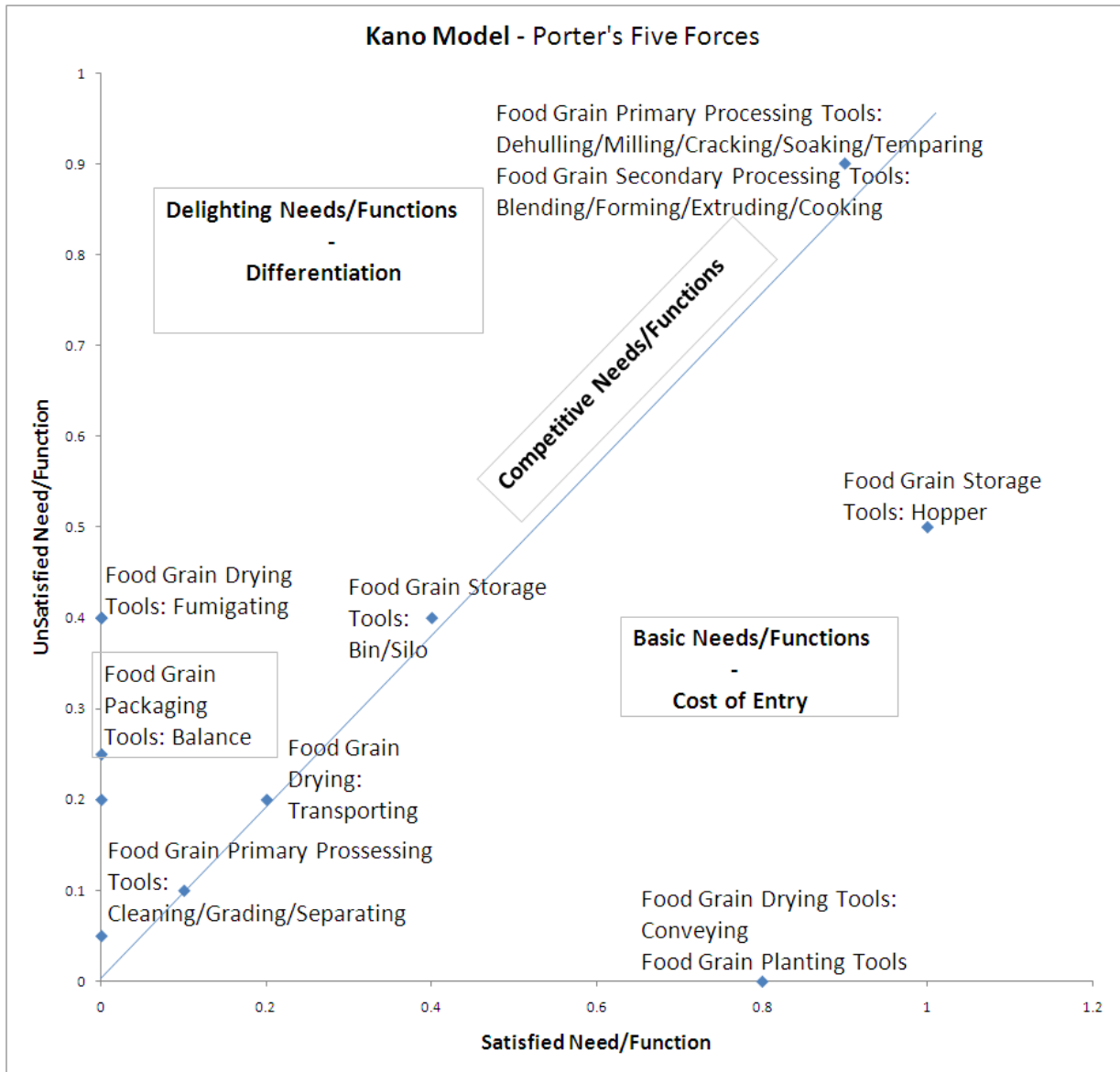

Figure 66: Kano Model and Porter's Forces for the ISPAAD and YFF Programmes

The activity diagram, the input - output concept diagram and the block flow diagram are typically used as design mapping models to abstractly represent the products which benefit from the Analytical Kano Model (Section 3.3 and Section 5.3.1):

1. **Activity Diagram:** The activity diagram illustrates the distinct activities followed by users when using the product (Figure 67). The activity diagram is a flow chart which may be described as having three phases, presented as a network layout of high-level user activities to show a full process cycle of product usage in each phase:
 - a. **Preparation Phase:** The organising activities to arrange all preliminary materials, energy, information and their sources that will be required during a process cycle period for product use from storage;

- b. Operation Phase: The consumption activities of the required amount of materials, energy and processing of information during product use; and
- c. Maintenance and/or Conclusion Phase: The sustaining and winding up activities to get ready for product storage.

Different users may use the product in different ways. All these different ways would be illustrated as patterns in the activity diagram. The activity diagram would therefore show different product characteristics aligned to the choice of activity patterns followed by the users; a chain of parallel user activities would guide the choice of parallel functions, and may be accomplished through distinct sub-assemblies.

The activity diagram assists product design productivity to reduce product development cycle time. Concurrent engineering, which by nature involves multidisciplinary product design teams, is one of the management processes being developed for this purpose (Marco et. al., 2000). This implies the formulation of alternative product architectures. Figure 66 shows the focal point chosen for the grain planting product as indicated by the product boundary. The boundary is affected by the interaction between the user and the functions of the product. The scope of the product activity derived from the product boundary should be defined such that it receives inputs from, and providing outputs to the user and the environment.

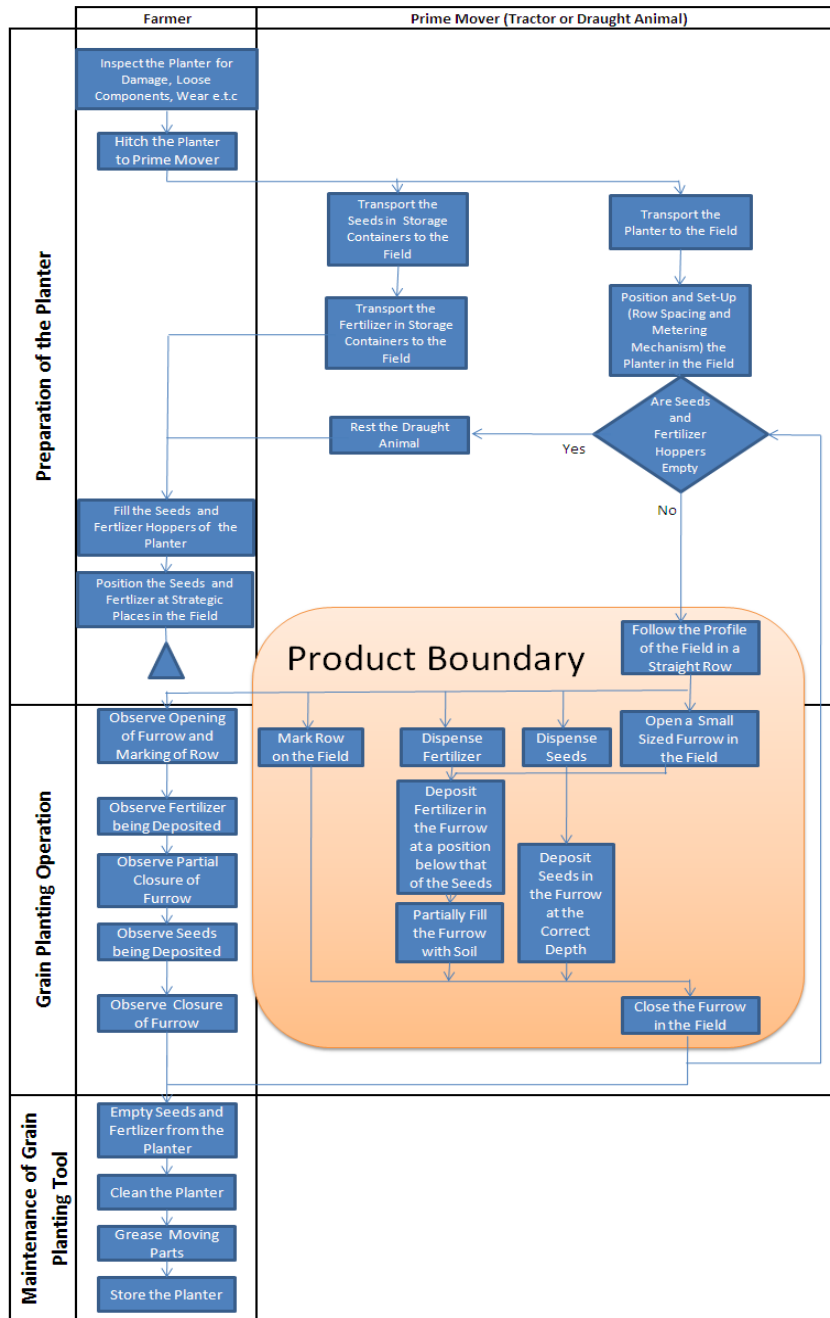

Figure 67: Activity Diagram for the ISPAAD and YFF Programmes (focusing on the Grain Planting)

The activity diagram is eventually incorporated as part of the users' manual document.

- Block Flow Diagram:** The block diagram assists the design team to focus on the most important overall need for a product. The overall product function depends on the overall need for the product. A product may serve different needs or may be used differently by customers. There are three types of flow: material, energy and information. The three types of flows associated with the overall need are identified as well as the three types of outputs resulting from the translation of the overall inputs by the overall function. Guided by the product boundary in the activity diagram, the overall function of the product is

expressed in terms of the transformation of inputs into outputs using the input – output concept diagram. Different input – output concept diagrams should be drawn for all the patterns of use depicted in the activity diagram. Different product alternatives may be designed for each of the usage patterns. There are four steps required to convert an input – output concept diagram into a block flow diagram:

Step 1: The primary flows, transformation rates or change in effects, of materials, energy and information from the activity diagram are identified and recorded with associated measurement units but with little regard for any dimensional consistency between the transformations i.e. an input-output qualitative representation record in the format: active verb – noun – dimension, measurement unit (Table 22). A flow, transformation rate or change in effects is therefore a technical or physical observable fact fundamental to a product; hence there are three primary flows or transformation rates: material flow, energy flow and information flow.

Material transformation rate, normally referred to as mass flow-rate, has dimensions of mass per unit time e.g. kg/s, energy transformation rate has dimensions of mass and length per unit time e.g. power (W) and information transformation rate, usually referred to as information processing rate may have dimensions of as either bits per unit time e.g. byte including “yes/no”, “on/off”, “high/medium/low”, “zero/one” or, more conveniently, a textual description of the information.

Recorded measurement units may be derived such as volume, force and power which may be derived from mass. The change in effects may be latently or actually exhibited but both must be recorded. Dimensional consistency is required from the sixth design principle or rule to the twelfth design rule.

Customer Need	Expected or Actual Effect (Transformation)	Importance (Kano Model)	Transformation Rate
Means for Opening/Closing the Soil	Opens/Closes a Trench or Furrow	Basic Function	5 Open Furrow [Force, N]
	Depth the Furrow	Basic Constraint	5 Furrow Excavation Rate [Length, m]
	Force for Compacting the Soil after Covering	Basic Function	5 Compact Furrow [Force, N]
Means for Planting Seeds	Area of the Seed Storage Opening	Basic Constraint	5 Size of Seed Storage Opening [Length, m ²]
	Volume of Stored Seed	Basic Function	5 Contain Seeds [Length, m ³]
	Frequency of Seed Depositing	Basic Constraint	5 Seeds Depositing Rate [Time, s ⁻¹]
	Average Seed Population per Unit Area	Basic Constraint	5 Seeds Flowrate [mass/time, kg/s]
	Volume of Soil Covering Seeds	Basic Function	5 Cover Seeds [Length, m ³]
Means of Fertilizing the Soil	Area of the Fertiliser Storage Opening	Basic Constraint	5 Size of Fertilizer Storage Opening [Length, m ²]
	Volume of Stored Fertiliser	Basic Function	5 Contain Fertilizer [Length, m ³]
	Frequency of Fertiliser Depositing	Basic Constraint	5 Fertilizer Depositing Rate [Time, s ⁻¹]
	Average Fertiliser Population per Unit Area	Basic Constraint	5 Fertilizer Flowrate [mass/time, kg/s]
	Volume of Soil Covering Fertilizer	Basic Function	5 Cover Fertilizer [Length, m ³]

Table 22: Design Principle or Rule 2: Materials and Energy Transformation Rates for the Food Grain Planting Product (focusing on some of the Basic Functions and Constraints only)

All individual primary flows and transformation rates are refined to identify the smallest logical sub-functions of the physical embodiment tools as utilised in the user process. In an input-output model, a flow goes through an operation or sub-function, is manipulated by the sub-function and exists in a new state; therefore it translates customer needs, through the Analytical Kano Model, to materials, energy and information flows when effects are displayed, expected or otherwise, during the use of the physical embodiment tools. Recall that in the preparation of the Analytical Kano Model, customer needs for which flows cannot be easily imagined are likely to be constraints (Table 22). A characteristic of constraints is that it affects all sub-functions of physical embodiment tool and sums-up their individual contributions.

Step 2: A chain of sub-functions and precise user procedures that represent the execution of the functional activities at user – product interface are meaningfully linked for each of the three types of primary flows or transformation rates; in this way, sub-functions represent the behaviour of the physical embodiment tool to produce the effect required by the user (documented in the Analytical Kano Model) and a procedure is a precise action by the user to complete the function structure (documented in the Porter’s Five Forces). It should be noted that with respect to the second design principle or rule, the Analytical Kano Model provides and transforms the Need-Attributes into Function-Attributes which are then exclusively dealt with by the Functional Domain.

Each of the sub-function chains are then summed up to represent the whole physical embodiment tool by connecting flows and adding interaction or control sub-functions (Figures 68, Figure 69 and Figure 70). Figure 69 and Figure 70 show block flow diagrams resulting from two input – output concept diagrams; they differ based on the materials conveying system. It is important for the sub-functions to be refined to their logical state such that they can be accomplished by a single solution such as an original equipment manufactured item (OEM). Sub-functions that cannot be fulfilled by OEM items must be indicated for the design team for awareness of what new designs are necessary to address the customer needs. These non-OEM item sub-functions should be refined to the level where they can be easily accomplished through the resources that are available to the design team.

Normally, in the Most Economically Developed Countries (MEDC) such as the United Kingdom, the variety of OEM supplier and the high standard of the supplies allow the design team to immediately find a solution that addresses the customer needs. Institutions in the United Kingdom were found to implement product design successfully in this way; institutions that implemented a similar approach in Botswana were not as successful. One option that had been used is to import the technology but this is very expensive; a recent example is the procurement of the snack making plant which was imported from South America; the product periodically fails and the after sales is support very costly.

The context of the technology must be taken into consideration for both the MEDC and the Least Economically Developed Countries (LEDC) through a check that it addresses the customer needs. Usually, in the LEDC the variety and standard of OEM is not top class; but this need not be the case. A solution proposed by this study is the development of OEM suppliers in Botswana through the Citizen Employment and Empowerment Programme (CE&E – ITech). The capacity to design the technology for the Grain/Food Production and Processing Programme (GFP&P-ITech) as identified in the National Policy on Agricultural Development (Government of Botswana, 1991) may be achieved by pairing with the manufacture of products suitable for the ISPAAD by the YFF using the North-South International Technology Transfer as a vehicle. In this report, this issue is further addressed through the Design Principle or Rule 4 by the institutional distribution cluster technique.

Step 3: All major primary flows or transformation rates between the sub-functions in the function structure must be labelled and checked according to the state of transformation for verification with the Analytical Kano Model and the Product Design Strategy (Section 6.3.1.1.1).

The sub-functions in the block flow diagram are clustered by identifying parallel and branching sub-function chains where each parallel sub-function chain may be a cluster typically sharing a primary dominant flow or sub-function chains having simple interactions. Clustering is one of the fundamental characteristics of a product design method and starts the documentation of effective layouts of names, physical embodiment sub-assemblies and parts and organisations of resources (human or otherwise).

Through clustering, configuration schemes may be developed; so is the clustering of personal skills where the result is referred to using such terms as workforce planning and with respect to physical embodiment tools it is called product architecture which, if selected, could be developed into a physical prototype model, functional graphical representation model or analytical prototype model.

There are primarily two types of architecture: product architecture and portfolio architecture. Portfolio architecture and programme are almost synonymous and this study aims to exploit their similarity.

Product architectures may be of integral or modular types. Integral product architecture results in a single or very few clusters of all sub-functions. Modular product architectures results in many clusters, called modules. In a well designed product, there is likely to be a one-to-one correspondence between a module and a name (in the configuration scheme), team work allocation (in a strategic workforce planning), groupings of formulae (in analytical prototype models) and physical prototype sub-assemblies (in physical prototype model).

In this study, the choice of modularity influences the institutional distribution cluster and demand management to effectively deliver G/FP&P – ITech through ISPAAD and CE&E-ITech through YFF to effectively handle the G/FP&P-ITech from the production process.

Step 4: the benefit of functional methodologies is the use of a “common functional basis”; for example, the use of state of the material phase such as solid, liquid or gas. The impact of this can be easily seen on the design of the G/FP&P – ITech programme; with the exception of the planter (Table 23 and Figure 68) all products share the same common functional basis representation (Figure 69).

Product	Basic Functions
Food Grain Planting	1. Open the Seed Furrow to the Proper Depth
	2. Meter the Seed
	3. Deposit the Seed in the Furrow in an Acceptable Pattern
	4. Cover the Seed and Compact the Soil Around the Seed to the Proper Degree for the type of Crop Involved
Food Grain Combine (Harvesting-Threshing)	1. Cutting (or Picking Up from Windrow)
	2. Conveying and Feeding the Cut Material to the Threshing Mechanism
	3. Threshing or removal of the seed from the head or pod.
	4. Separating the seed and chaff from the straw
	5. Cleaning the chaff and other debris from the seed

Table 23: Basic Functions of Grain Planting and Food Grain Combine (i.e. combined Harvesting and Threshing)

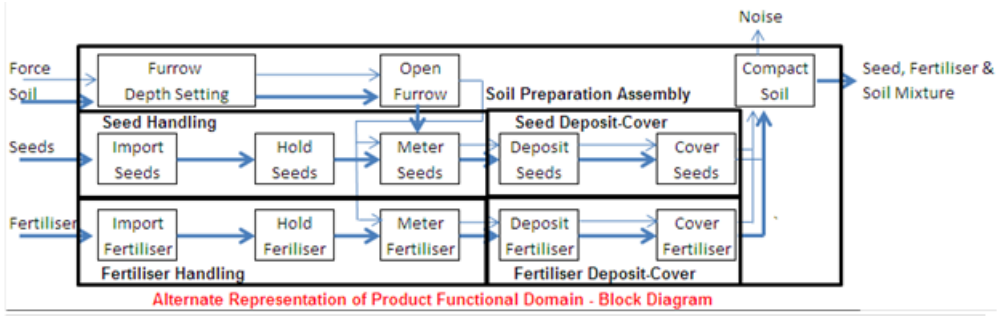

Alternate Representation of Product Functional Domain - Block Diagram

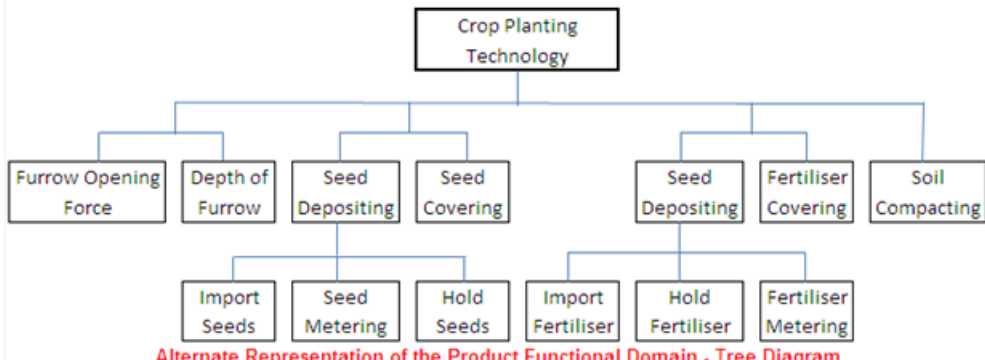

Alternate Representation of the Product Functional Domain - Tree Diagram

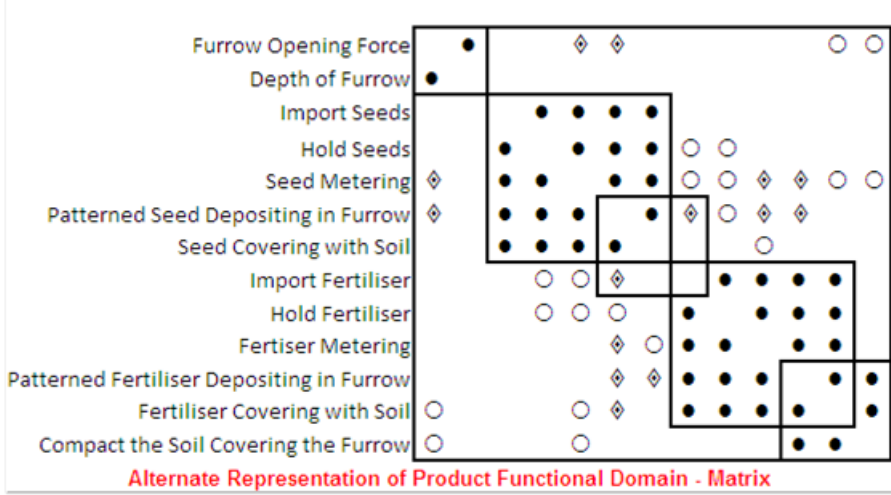

Alternate Representation of Product Functional Domain - Matrix

Figure 68: Design Rule 2 - Functional Domain - Grain Planting Product

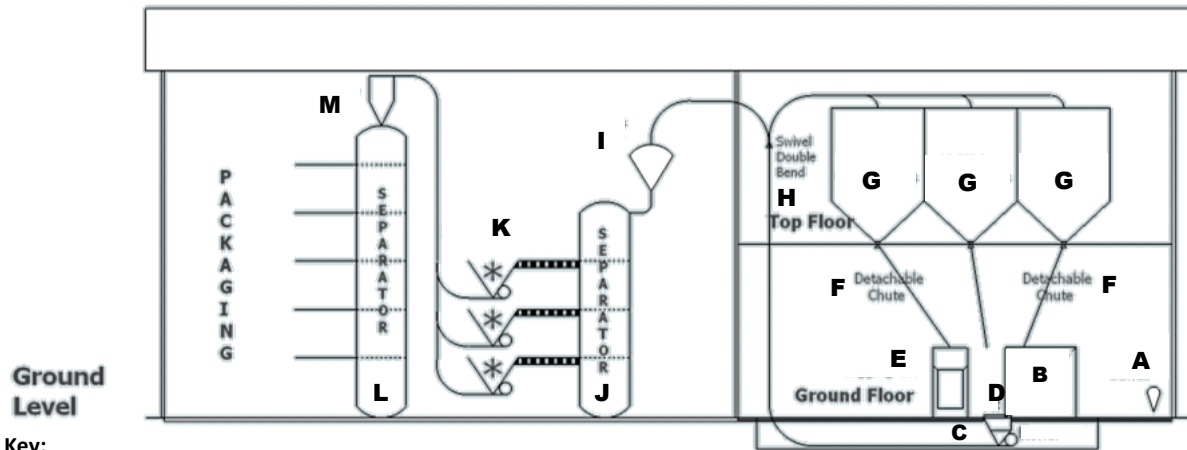

Key:

- A – (Receiving Weigher) Food Grain Packaging
- B – Primary Food Grain Processing (Movable Clean)
- C – (Pneumatic or Screw) Convey Food Grain
- D – Pit (with Screen)
- E – (Movable) Bagging-Off
- F – (Detachable) Chutes
- G – (Fumigate in Hopper, Bin or Silo) Store Food Grain
- H – (Swivel Double Bend) Direct or Deliver Food Grain
- I – (Inline Weigher) Food Grain Packaging
- J – (Clean, Grade or Sort Separator) Primary Food Grain Processing
- K – Primary Food Grain Processing (Dehull/Grind/Crack)
- L – (Grade Separator) Remove Crushed Shells/Package Kernels
- M – (Dust Cyclone Separator) Remove Crushed

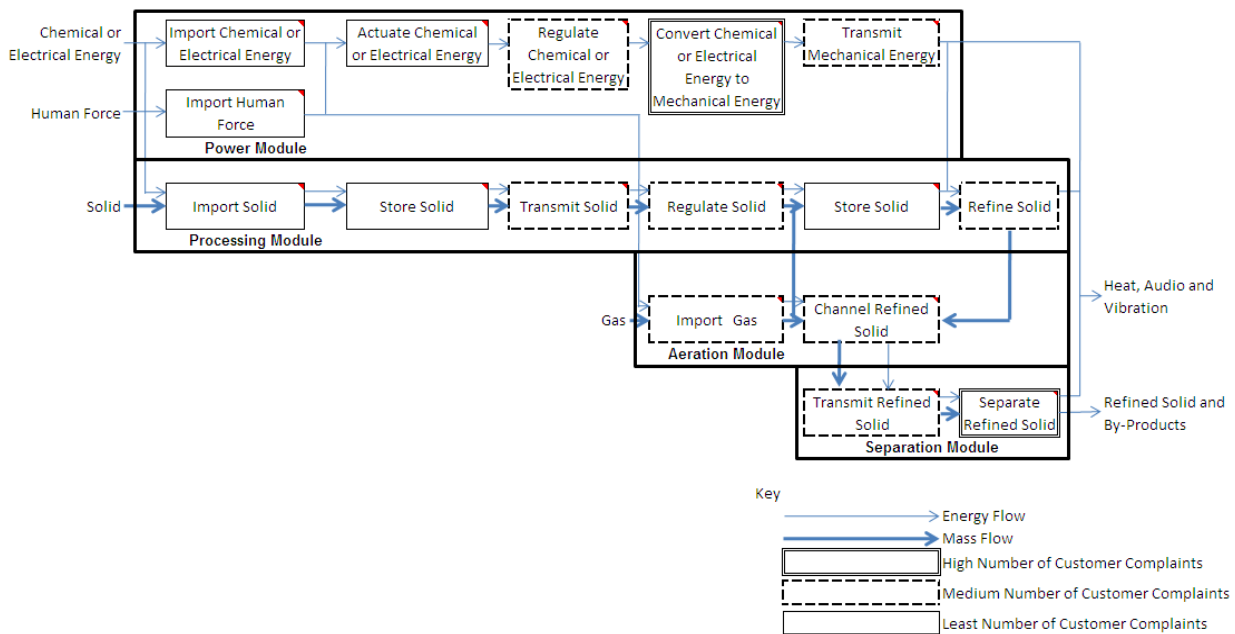

Figure 69: Block Flow Diagram (Pneumatic Conveyor) - G/FP&P-ITech Programme and Product Functional Domain (without the Farm Implements and Secondary Food Grain Processing)

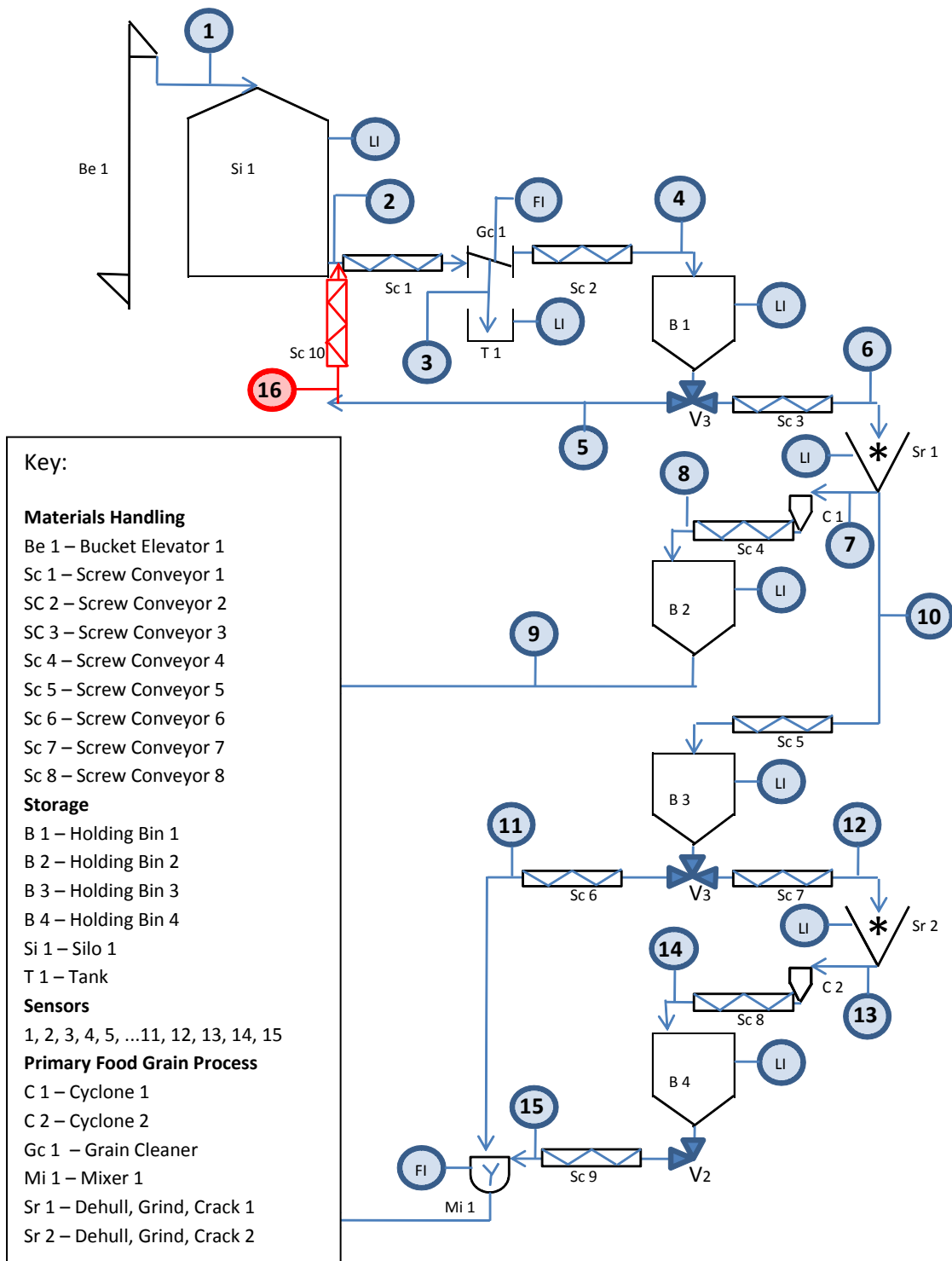

Figure 70: Block Flow Diagram (Screw Conveyor) - G/FP&P-I-Tech Programme and Product Functional Domain (without the Farm Implements and Secondary Food Grain Processing)

6.3.1.1.3 Design Rule 3

The strategic workforce planning process assists in establishing the required resources and skills including organisational structure of product design teams. Product architectures provide one way to achieve this through work allocation to teams to design specific modules.

Assuming a successful implementation of the second design principle or rule, the third design principle or rule make certain that suitable access to skills is ensured through such sources as employment, training, sub-contracting, partnerships or changing product design activities to suit the available types of skills.

The development of product architecture is a key milestone where important decisions are made on how the product will be divided into a single or several modules. The purposeful formation of the product architecture began to take shape from the second design principle or rule and is being revisited here. This also provides a sound foundation for organising and managing product design effort (Figure 71, Figure 72 and Figure 73). Different product architectures can be conceptualised that all satisfy the same block flow diagram. This necessitates the selection of the most optimum based on its implications on such issues as product cost, performance and design team formation and administration.

To illustrate the potent characteristic of product design drivers, once decisions such as product architecture are made, they remain almost unchanged for the rest of the product design process. For example, with respect to the second design principle or rule, product architecture starts the creation of effective layouts of sub-functions; with respect to the third design principle or rule, product architecture is where different tasks are completed subsets of the product design team; with respect to the fourth design principle or rule, product architecture affects the task allocation to institutions depending on the market segments. The choice of product architecture is itself informed by the results of the first design principle or rule.

There are two types of architectures which are useful for this study: product architecture and portfolio architecture. Product architecture affects the product design strategies based on performance and market requirements. Portfolio architecture affects the product design strategies associated with a group or family of products, i.e. decisions of whether to design a product platform comprised components shared in a group of product derivatives. This study aims to use portfolio architectures to address the needs of projects and programmes, where a project is a group of products designed by a single institution and a programme is a group of projects designed by several institutions.

There are two types of architectures:

1. Integral product architecture where the entire product block flow diagram is comprises of a single or very few product sub-functions clusters whereas a

fixed unshared portfolio architecture is when each product in a portfolio or a programme is unique and does not share any components with other product members in the portfolio; and

2. Modular product architecture where several clusters of sub-functions, called modules, are designed to implement the block flow diagram. In this study, the product modules are defined as integral sub-function clusters that have a one-to-one correspondence with a subset of a physical embodiment tools' constituents such as sub-assemblies or machines, and design team composition such as departments or institutions, whose effort is centralised to accomplish the block flow diagram. Product modules will also find effective use in considerations for demand management and institutional distribution cluster where product derivatives would be expected to share product modular platforms. To avoid time delays, the modularity in the programmes would be simplified by the incorporation of existing product technologies in Botswana as enhanced product derivatives (Cutherell, 1996) e.g. the block flow diagram and the manufacturing process related to the sorghum product technologies with eventual production processes through the YFF.

There are four classes of the function-based modularity (Ulrich et.al, 1991):

- Slot Modularity is where the same product component platform module is used across different products in a programme, each product has the same interface and the product component platform module is standardised to perform only one function. This allows the product to perform multiple tasks;
- Bus Modularity is where a main product sub-assembly module uses a standard interface that accepts any combinations of different functioning modules. This allows the product to perform multiple functions;
- Sectional Modularity is where linked modules, referred to as sections, which have several identical interfaces but can individually accomplish different product sub-functions; and
- Mix Modularity which combines several standard components together through a web of modules rather than a chain of sections.

There are also four classes of manufacturing-based modularity which group sub-assemblies based on manufacturing technique and assembly (McAdams et.al, 1991):

- Original Equipment Manufacturer (OEM) Modules are supplied wholesale where it is cheaper than to manufacture them in-house;
- Assembly Modules have components that solve related functions which are grouped to simplify manufacturing assembly;
- Sizeable Modules have components that are exactly the same but vary in physical scale; and

- Conceptual Modules which solve the same functions but have different physical embodiments to apply a change in their manufacturing without affecting the manufacturing of the rest of the product.

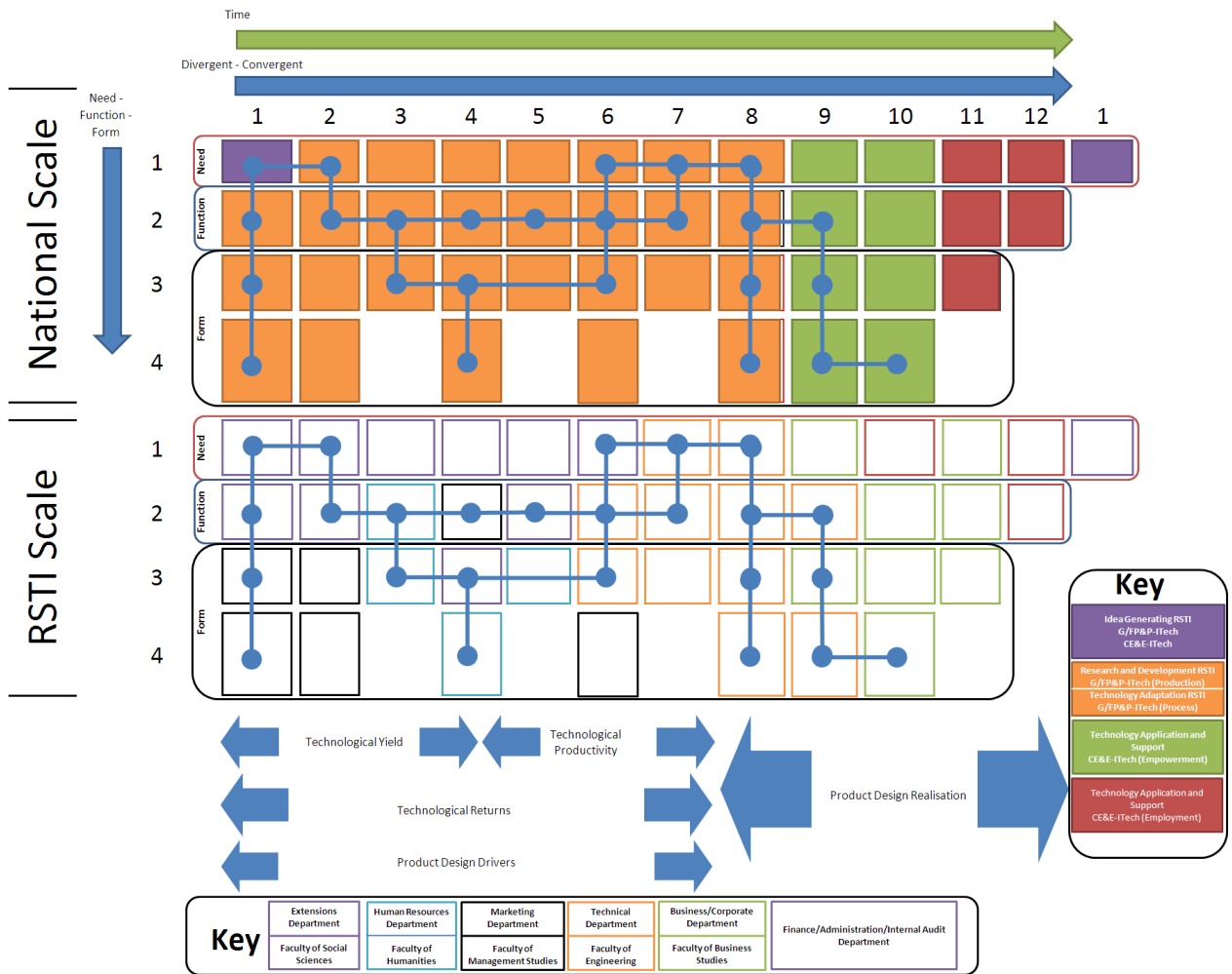

Figure 71: Design Principle or Rule 3 – Strategic Workforce Planning for G/FP&P-ITech (ISPAAD) and CE&E-ITech (YFF) Programme

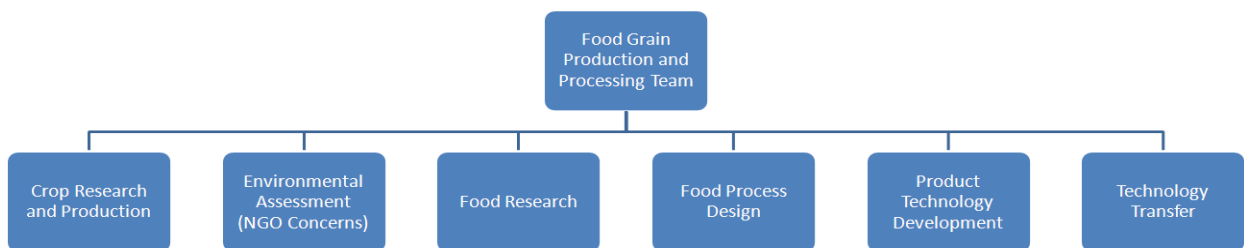

Figure 72: Design Principle or Rule 3 - Organisational Structure for G/FP&P-ITech (ISPAAD) Programme Team on a National Scale

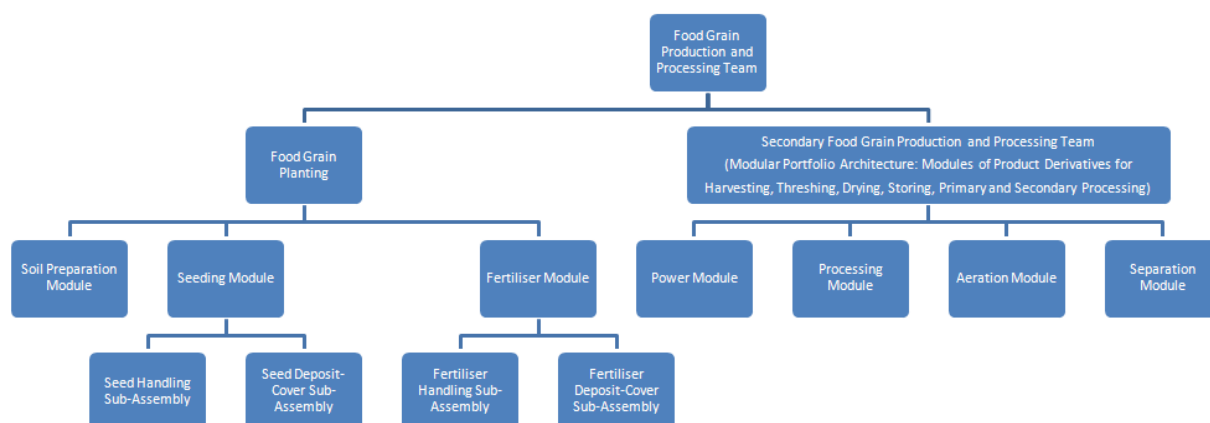

Figure 73: Design Principle or Rule 3 - Organisational Structure for G/FP&P-ITech (ISPAAD) Project Team on a RSTI Scale

6.3.1.1.4 Design Rule 4

Five market segments were identified for the deployment of ISPAAD (G/FP&P-ITech) according to the acceptance to use the technology (Figure 74) – a different technique that is advocated for is the use of the quality ladder where the early markets would be the MDC located North of the Equator, such as the United Kingdom, and the mainstream markets would be the LDC located South of the Equator, such as Botswana. The higher the steps of quality ladder in terms of the number of new incorporated sub-functions, the more suitable the product family for addressing such issues as employment (Figure 75):

1. Agricultural Educational and Research Institutions: The Department of Agricultural Research, Crop Production Department, Botswana College of Agriculture, Barolong Vocational Trading Centre would likely be the first to use new agricultural technology for training and have the highest concentration of agricultural experts generally providing a network of extension services. They are also valuable in the knowhow for testing agricultural technology.

This market segment is driven by the search for improvements agricultural technologies and dissemination of agriculture related information. The market segment is expected to be less tolerant of failures associated with primary and secondary food grain processing, packaging and quality control including storage fumigation.

2. Agricultural Project Funding Institutions and Government Agricultural and Rural Development Programmes: Other than Integrated Support for Arable Agricultural Development (ISPAAD) and Young Farmers Fund (YFF), national programs aimed at agricultural development, include National Master Plan for the Arable. Agriculture and Dairy Development (NAMPAAD). These programmes are funded through the National Development Bank (NDB), Citizen Entrepreneurial Development Agency (CEDA) and supported through Local Enterprise Authority (LEA).

This market segment requires new agricultural technologies that match their programme strategies; in addition, they are targeted in this study because they

are the funds expenses control instruments used by the Government of Botswana and International Donors. The market segment is also expected to be less tolerant of failures associated with primary and secondary food grain processing, packaging and quality control including storage fumigation

The Agricultural Educational and Research Institutions as well as the Agricultural Project Funding Institutions and Government Agricultural and Rural Development Programmes comprise the early markets in Botswana and, in line with the theory of technology adoption lifecycle, new agricultural technologies should be introduced to them first.

3. Agricultural Cooperative Societies and Commercial Farmers: Agricultural cooperatives started to proliferate over Botswana from mid 1970s to market agricultural produce and sell or hire agricultural inputs (Oladele. et. al, 2009). Arable farming is common in such areas as Tuli Block, Pandamatenga, and Barolong Farms and accounted for 1% of the total number of farms in 1993, but accounted for 37% of the total production of cereals and pulses for sale mainly to the Botswana Agricultural Marketing Board according to the Ministry of Finance and Development Planning (1997) as cited by Kgathi. et. al., (n.d.).

This market segment is characterized by an aptitude to acquiring new agricultural technologies for progressiveness; however, they require risk mitigating measures often offered by the Agricultural Project Funding Institutions and Botswana Government (the second market segment; Figure 74) – they are sensitive to costs associated with new agricultural technologies.

The communal farmers make the last two market segments. Communal crop lands in Botswana cover around 269 900 hectares or 5% of the country producing an combined average of 16 669 tonnes for all cultivated crops – the average yield per hectare for all crops is 0.132 tonnes per crop is (Fraser and Mabusela, 2003). On average 4,8 hectares (80%) of the total land available for cropping per household is cultivated. The main cereal crops grown include namely sorghum, maize, millet, and pulses.

4. Communal Farmers with Mechanical Draught Power and living in Villages Supplied with Electricity: The farm tractor, as a source of power, is an important part of the arable agriculture, generally increasing the planted hectares of land compared to other draft-powered farms. Farmers have cited reasons for not adopting innovation in farming technologies to lack of implements, too much work, lack of funds and lack of draft power according to Baker and Siebert (1986) as cited by Acquah (2003). All these factors have been taken into consideration in this study.

These farmers would purchase the new agricultural technologies from observing the successful large scale farmers confidently using the technology and having it as a standard especially technologies that use the tractor as a power source.

- Communal Farmers with Animal Draught Power: These communal farmers would only change to the new agricultural technology when the old technologies have been phased out; because they need assurance on the capability of any technology from their own usage of it over long periods and certain after-sale support. According to Fraser and Mabusela (2003), they make 64% of the households in communal areas.

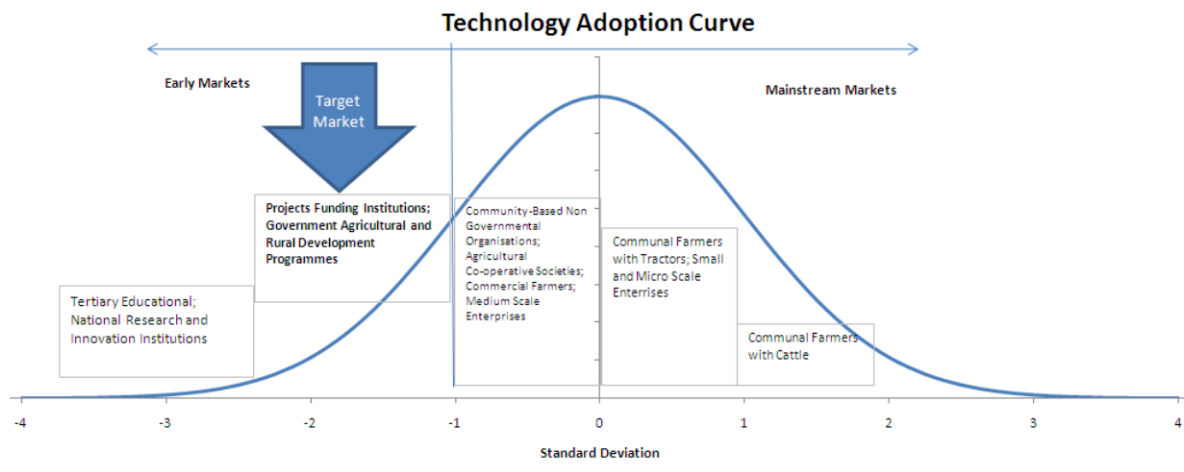

Project Funding Institutions; Government Agricultural and Rural Development Programmes; SMMEs; Commercial and Communal Farmers with Tractors

Sort Morama Beans	36%	Lowest Customer Performance Tolerance Level
Store Morama Beans	27%	
Kill Insects Trapped in Incoming Morama Beans	9%	
Convey Morama Beans through the Process	8%	
Receive, Direct or Deliver Morama Beans	6%	
Remove Impurities from Morama Beans	5%	
Crack Morama Beans	5%	
Package Morama Kernels	4%	
Remove Crushed Shells	0%	
Weigh Incoming and Cleaned Morama Beans	0%	Highest Customer Performance Tolerance Level

Tertiary Educational; National Research and Innovation Institutions
 The bigger the Sectoral Area, the more acceptable is the Design for that Function at Lower Customer Performance Tolerance

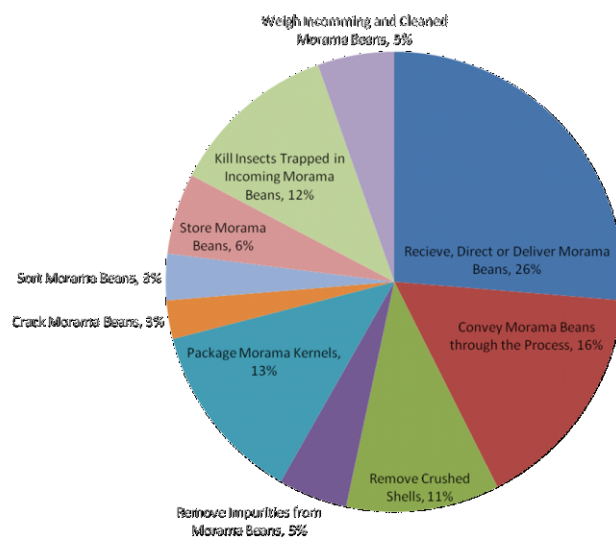

Figure 74: Design Principle or Rule 4: Crossing the Chasm – G/FP&P ITech ISPAAD (Morama Milling Plant) Case Application (the YFF not included for clarity)

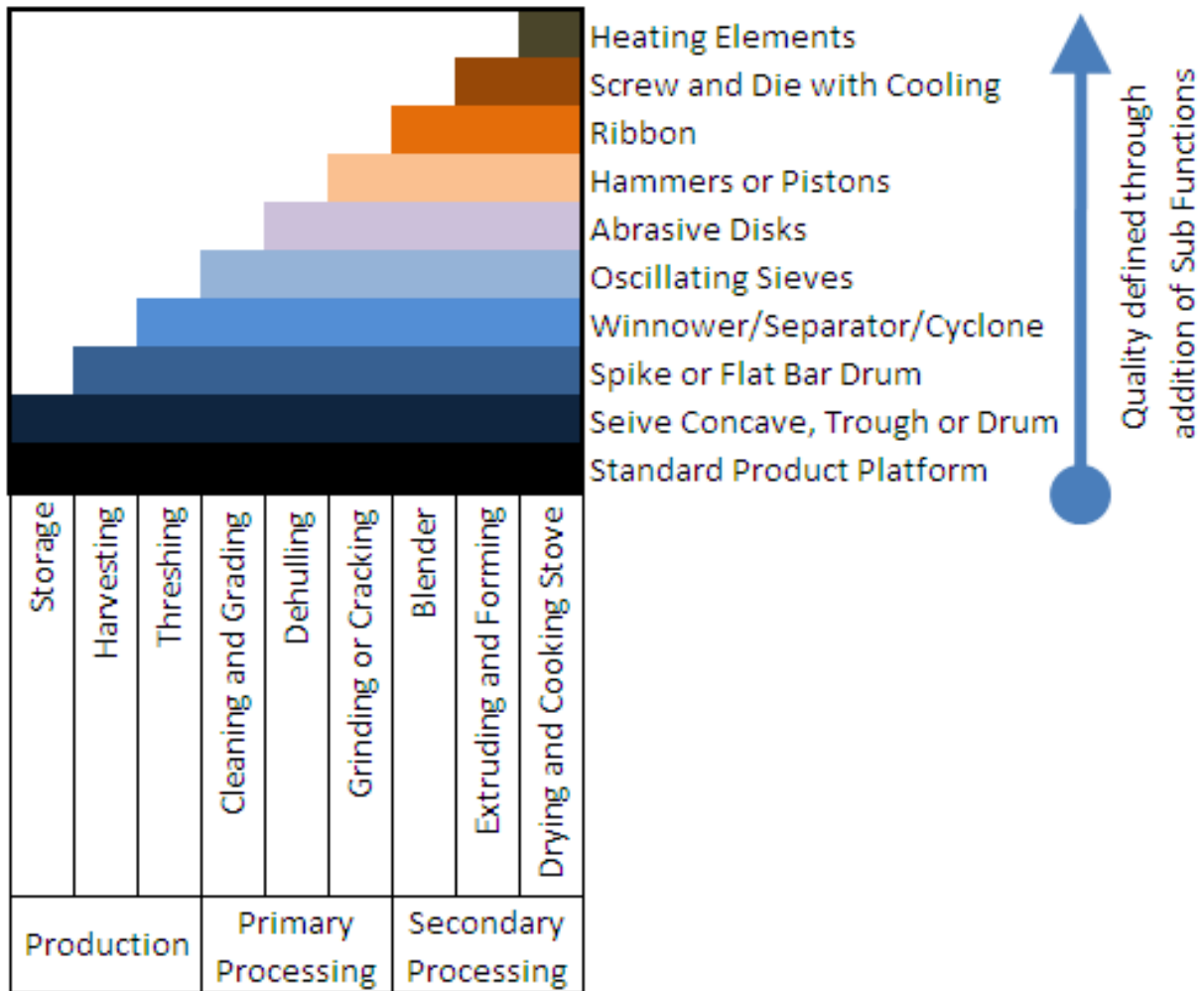

Figure 75: Quality Ladder – ISPAAD and YFF Programmes

Institutional distribution clustering or the development of industrial districts eventually causes:

1. Learning to take a Virtual, non-spatial dimension
2. Increases in diversity and distribution of competencies and disciplines

According to Marshall (1890), Jacobs (1969) as cited by Scott (1997) and Porter (1990) as cited by Asheim (2002) there are several economic and productivity advantages of industrial districts (Table 24).

Marshal (1890)	Knowledge Spillovers	Reduced Cost of Acquiring Knowledge
		Privileged Access to a Network of Suppliers and Customers
		Immediate Access to a specialised Labour Market
	Labour Market Risk Pooling	Competition for (Human) Resources
	Vertical Linkages	Matching Costs i.e. re-location of Suppliers and Customers reducing transaction and search costs
Jacobs (1969)	Urbanisation	Co-Location of Firms with Diverse Industrial Structure (Productivity Growth are faster for Firms Located in Diversified Clusters)
Porter (1990)	Industrial Competitiveness	Local Competition fosters Innovation and the Dissemination of Information
		Industrial Concentration stimulates Productivity Growth

Table 24: Economic and Productivity Advantages of Institutional Distribution Cluster

Already Botswana has RSTI exclusively in Gaborone and Kanye. The economic and productive advantages would be more easily reaped from a dominating innovation hub of an RSTI in the South-East and Southern Districts covering places within a boundary delimited by Lobatse, Mochudi, Molepolole, Ramotswa and Tlokweng and satellite centres in the other districts (Figure 76). The implications for tying YFF with existing Technical or Vocational Training Institutions in these satellite centres would especially aid the pooling of labour market risk.

Through the proposed design guidelines, this study provides a means, probably as yet untried, of deployment of ISPAAD through the design of product families that specifically take the skill level that is abundant in Botswana into consideration (Figure 70, 71 and 76). All the modules are designed to be manufactured by small, micro and medium scale enterprises (SMME) managed by the youth and spread within a district; each district would then have main area for assembling specific physical assemblies some of whose sub-assemblies would have been made in other districts; these youth-managed SMME would have to learn and use skills centralised around product design as well as getting effective product design enabling support from RSTI (Figure 72). For this to work smoothly, the supply chain and the product types would have to be matched possibly through market responsive supply chains and vendor managed inventory. This is in line with the market segments since the technology will be first introduced in educational institutions.

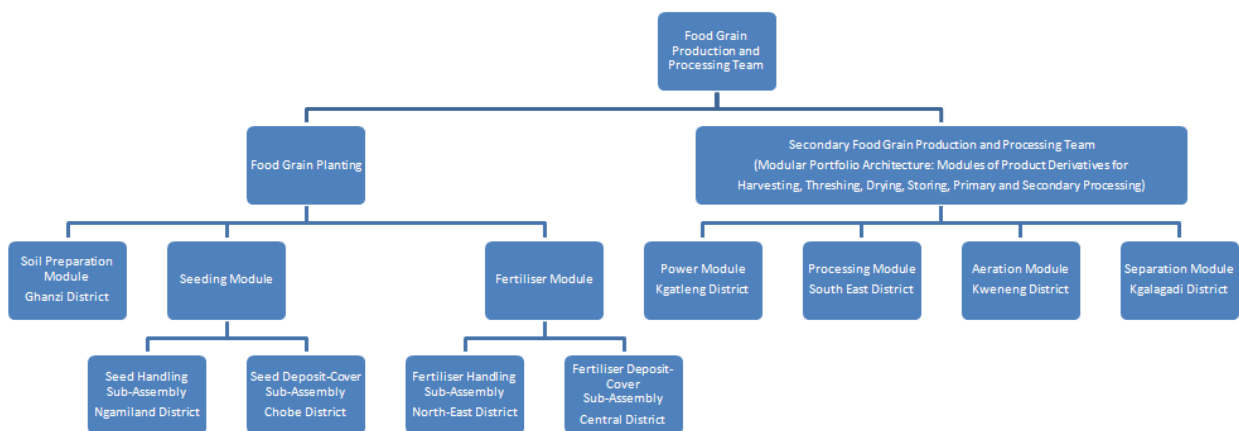
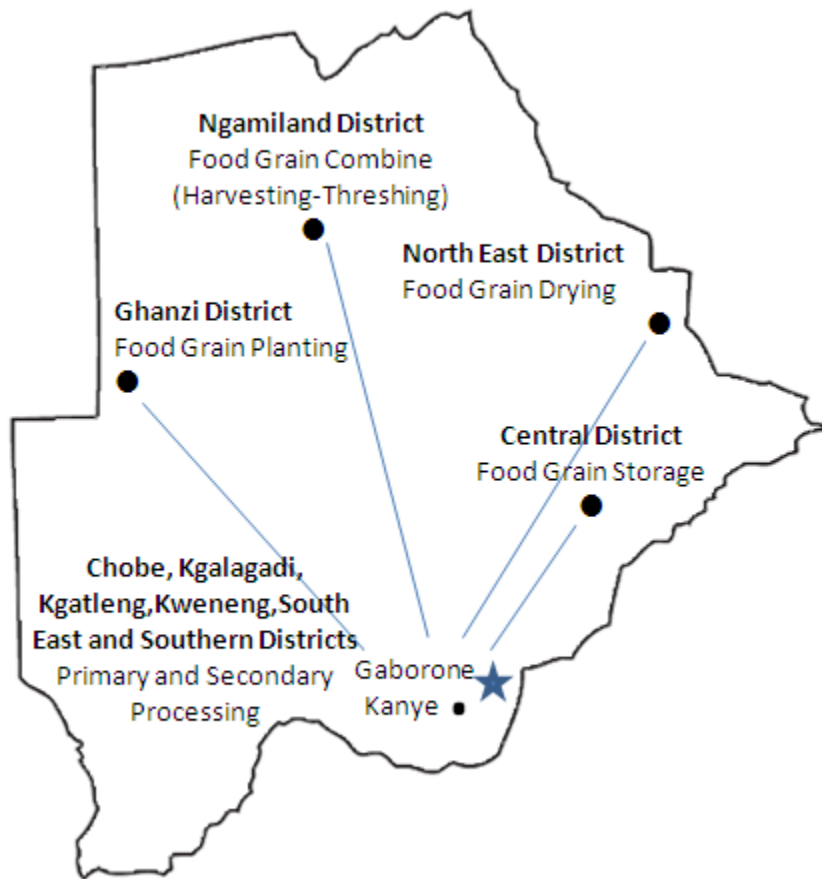

Figure 76: Design Principle or Rule 4: Institutional Distribution Cluster (Industrial Districts) for the G/FP&P-ITech (ISPAAD) and the CE&E-ITech (YFF) Programme Case Application

6.3.1.1.5 Technological Yield Determination:

Grandstrand (1998) notes that technologies have, among other properties², an artefact link (i.e. technology is linked to products and processes that produce them) and a 'practical purpose' link (i.e. technology intends to achieve some level of technical performance); hence, the product design drivers are ultimately related to product realisation with more prominent in the interpretation of technological

² Other properties of technology include natural science link, code -fiability link (through formal language such as mathematical and chemical formulae, drawings and computing rules) and patent-ability link (for ease of registering and protection)

forecasting and roadmap (i.e. the tenth design principle or rule). The difference between the current technical performance and the natural technological limits is called the technical potential. Technological yield is a measure of the extent to which the technical potential is translated into actual technical performance. The greater the technical potential, the greater the anticipated speeds of technological advance that can be forecasted relative to the establishment of a dominant technology.

The natural technological limits will eventually be documented on the product design specifications probably as constraints. Wyk (1985) suggests three steps to assist in determining the technological limits:

1. The Range of Technologies;
2. The Trends in Technological Advances; and
3. The Determination of Structural Limits and Performance Limits.

The design professional must choose a technical performance variable first.

The Range of Technologies: The classification of technologies may be established through the three major primary flows in the product architecture. Each of these primary flows is further refined to three types of sub-functions or sub-function groupings typically referred to as modules:

1. Processing Modules: These convert inputs into new outputs;
2. Transporting Modules: These change the locality of inputs but not their composition; and
3. Storing Modules: These keep the inputs, without changing them, in a given locality for various time durations.

This results in a “nine-cell classification of technologies”.

The Trends in Technological Advances: Two main technological trend types are identified with six technological trends:

1. Structural technological trend type (STTT) which are related to the artefact link of technology:
 - a. Range of Size Increases: Certain types of artefacts can assume different sizes from the smallest to the largest.
 - b. Range of Complexity Increases: Certain types of artefacts can be designed and developed through successive generations which become increasingly equipped to perform specialised functions i.e. as product derivatives (Section 6.6.2). Product is defined in this report, to include all activities in the proposed conceptual framework. Therefore, the ISPAAD programme will have eleven products each engaging the entire proposed conceptual framework.
2. Performance Technological Trend Type (PTTT) which are related to the “practical purpose” link of technology:

- a. Range of Efficiency Increases: This refers to the continuous improvement in the ratio of outputs to inputs achieved through improved designs (Section 6.6.2).
- b. Range of Capacity Increases: This refers to increased capacities or transformation rates of successive product generations expressed per unit time. Whereas efficiency is intensive related to the output and the input i.e. an intrinsic constraint contained within the technical performance variable chosen by the design professional, capacity is extensively related to the output rate and input rate i.e. a constraint due to factors that are external to the technical performance variable.
- c. Range of Density Increases: This refers to the functional capability being packed into an artefact of increasing or decreasing physical size as may be expressed in units per unit area.
- d. Range of Accuracy Increases: This refers to the close tolerances with which artefacts are produced using measurement tools or devices that have high precision that which they are able to record or communicate to the producer e.g. a multi-meter that can measure electric current to a precision greater than its display.

The limits of these trends in technological advances when combined with the nine-cell classification of technologies result in a “veritable technological map” consisting of 54-cell matrix of nine technology classifications by six trends in technological advances (Table 25, 26 and 27). The veritable technological map summarise the many characteristic of technological evolution (Wyk, 1985) which are useful for the eight design principle or rule and is on the driving seat of the **Teoriya Resheniya Izobratatelskikh Zadatch** (TRIZ).

Within the context of product design, the veritable technological map is useful for recording the measured relationship between current technical performances (Table 25) against natural technological limits (Table 26) otherwise known as the technical potential which in turn is useful for the determination of the technological yield and the technological productivity i.e. the product design drivers. Technological yield is a measure of the extent to which the technical potential is translated into actual technical performance; therefore a decision must be made as to how much to reduce the technical potential (Table 27).

Primary Flow or Transformation Rate	Module		Structural Variable		Performance Variable			
			Current Size	Current Complexity	Current Efficiency	Current Capacity	Current Density	Current Accuracy
Mass	Power	Processing						
		Transporting						
		Storing						
	Processing	Processing						
		Transporting						
		Storing						
	Aeration	Processing						
		Transporting						
		Storing						
	Separation	Processing						
		Transporting						
		Storing						
Energy	Power	Processing						
		Transporting						
		Storing						
	Processing	Processing						
		Transporting						
		Storing						
	Aeration	Processing						
		Transporting						
		Storing						
	Separation	Processing						
		Transporting						
		Storing						

Table 25: Template for Current Technical Performance for the G/FP&P – ITech

Primary Flow or Transformation Rate	Module		Structural Limits		Performance Limits			
			Size Limits	Complexity Limits	Efficiency Limits	Capacity Limits	Density Limits	Accuracy Limits
Mass	Power	Processing						
		Transporting						
		Storing						
	Processing	Processing						
		Transporting						
		Storing						
	Aeration	Processing						
		Transporting						
		Storing						
	Separation	Processing						
		Transporting						
		Storing						
Energy	Power	Processing						
		Transporting						
		Storing						
	Processing	Processing						
		Transporting						
		Storing						
	Aeration	Processing						
		Transporting						
		Storing						
	Separation	Processing						
		Transporting						
		Storing						

Table 26: Template for Technological Map displaying Technological Limits for the G/FP&P – ITech

Primary Flow or Transformation Rate	Module		Structural Variable		Performance Variable		
			Size Difference	Complexity Difference	Efficiency Difference	Capacity Difference	Density Difference
Mass	Power	Processing					
		Transporting					
		Storing					
	Processing	Processing					
		Transporting					
		Storing					
	Aeration	Processing					
		Transporting					
		Storing					
	Separation	Processing					
		Transporting					
		Storing					
Energy	Power	Processing					
		Transporting					
		Storing					
	Processing	Processing					
		Transporting					
		Storing					
	Aeration	Processing					
		Transporting					
		Storing					
	Separation	Processing					
		Transporting					
		Storing					

Table 27: Template for Technical Potential for the G/FP&P – ITech

As mentioned before, the product design strategy (selected using the first design principle or rule) effectively eliminates technological research and development which uses trial and error through craftsmanship. Product design, for both the MEDC and LEDC, must use and be limited by scientific applications visible as engineering and management advances; product failure may very well be related to activities that do not relate science to technology i.e. science is related to technology by product design.

Programmes in LEDC such as ISPAAD and YFF in Botswana may be realised through a two stage institutional distribution cluster or industrial district, the usefulness of the first stage depends on the deficiencies of the second stage (Figure 78):

1. International North-South Technology Transfer where the programmes would rely on OEM Modules imported from the MEDC to the LEDC through RSTI which has product design capacity i.e. to identify products and implement design principles or rules, inclusive of those identified in this study; and
2. RSTI Technology Transfer where the technology already developed in the LEDC is evolved.

The technical potential would therefore inherently depend on the targeted market i.e. the geographical place where technical performance is closest to the natural technological limits within targeted markets. In an ideal situation, the above stages would be best attained through a Two-Way Directional International North-South Technology Transfer (TWDINSTT).

Devarajan et. al. (2001) found that the relationship between poor performance as recorded by GDP and investments in African countries, including

Botswana, was non-linear and that low investment as well as low growth rates seemed to be symptoms of the following factors – all of which must be addressed concurrently and not in isolation (Figure 77).

1. Low usage of available capacity;
2. Limited absorption of acquired skills;
3. Loss of highly productive sectors (into low productivity);
4. The existence of state-owned enterprises; and
5. Poor policies.

Both the technological yield and technological potential should be included as factors determining GDP of LEDC. The expected results would contribute to the achievement of the United Nations Millennium Goals through the six programmes identified in this study.

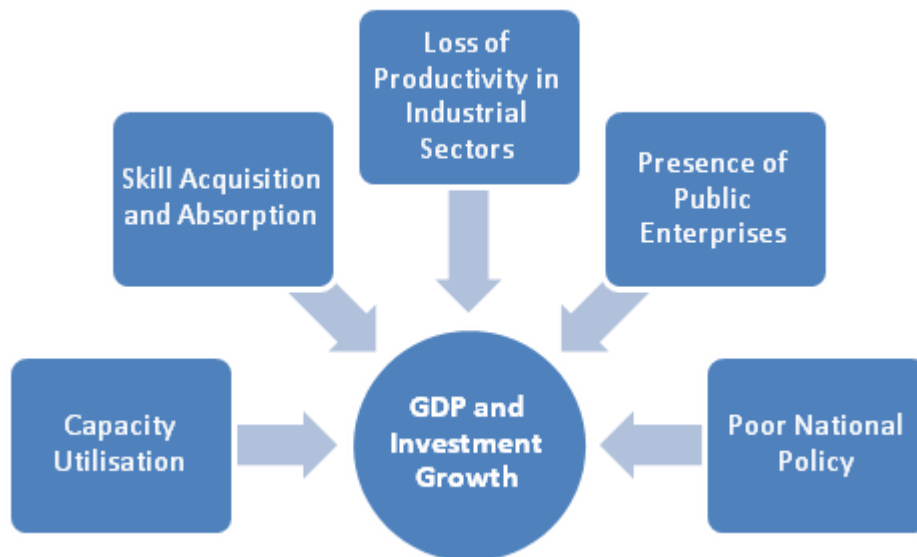

Figure 77: Components of GDP and Investment Growth



Figure 78: Two-Way Directional North-South Technology Transfer

6.3.1.2 Technological Productivity - Design Rules 5 - 7

The technological yield might logically be thought of as the first step towards determining the technological productivity. It is treated separately because its determination is more involving, requiring not less than nine management and engineering techniques from the proposed conceptual framework, and requires relatively more resources to be committed to match the technological yield. Technological productivity is the ratio of the improvement in the technical performance of a product to the increment of the effort required to gain that improvement in the product technical performance.

The technological productivity is determined through the fifth, sixth and seventh design rules (Table 28); like the technological yield, the choice of product design method template has a direct bearing on the determination of technological productivity

Rule Number	Rule or Principles
5	The graphical representation, or otherwise, of visual descriptions to display the perceptions, mental position, image or identity of the product in customers or potential customers and to control economic demand and avoid recession through assigning responsibilities and general tasks to resources (human or otherwise) emanating from SWOT analysis with respect to the product.
6	Market Trend Analysis and Competitive Analysis (Determination of profiles of product features within the context of application of science, engineering and management principles, laws and equations to the development of material, energy and information consuming devices). The change of product features profiles are over time period is examined with respect to customer need change over the same period.
7	Objectives and constraints specified as target value (range), (engineering) metrics and parameters trade-offs (e.g. A set of mathematic inequalities - linear programming, materials). The product design specification is comprised of all techniques utilising design principles or rules 1 to 7.

Table 28: Technological Productivity - Design Principles or Rules 5 – 7

Chiou, et. al. (1999) simplified the computation of the Technology Oriented Total Productivity Model (TOTPMM) proposed by Edosomwan (1987). The power of the TOTPMM is on its association with the technology lifecycle, a factor which was retained in the simplified model, corresponding referred to as Technology Oriented Productivity Measurement Model (TOPMM). TOPMM is a general model with four steps but requires modifications for use in specific applications.

This study adapts the TOTPMM to the determination of the technological productivity. The proposed method is a practical approach that has the following three broad steps:

1. Understanding the Complexities of Technologies (Design Rule 5) - this being the third step of TOPMM;
2. Identifying Key Technologies and Calculation of the Technological Productivity (Design Rule 6) - this being the first, second and the last step of TOPMM; and
3. Specifications of Key Technologies (Design Rule 7).

All these three steps must be interpreted within the context to which the technology is being applied.

6.3.1.2.1 Design Rule 5

To understand the complexities of technologies applied to products, there is need to develop a strategy for the service provided by the products to its customers. This entails:

1. Market Positioning: The mental image of ISPAAD and YFF service by the customers' or clients;
2. Demand Management: The transitions of the provision of ISPAAD and YFF service;
3. Job Descriptions: The operations to deliver the ISPAAD and YFF service (Appendix 8); and
4. Business Re-Engineering: The continuous improvements to both ISPAAD and YFF.

All of these would set the objectives for financial management during the deployment of these services which are key for the ninth, tenth and eleventh design principles or rules. The main objectives are to understand and influence the customer demands for service as well as the provision of enough capacity required to meet these customer demands which may vary with respect to time e.g. Botswana has four distinct seasons which all affect the ISPAAD and YFF; summer season occurs between November and January and is normally the rainy season that provides a window for planting, but rain and other weather elements are destructive to the quality of crops during the harvest season in autumn from February to April. The capacity to provide for these service fluctuations must be understood and designed into through the eleven ISPAAD products (Figure 79).

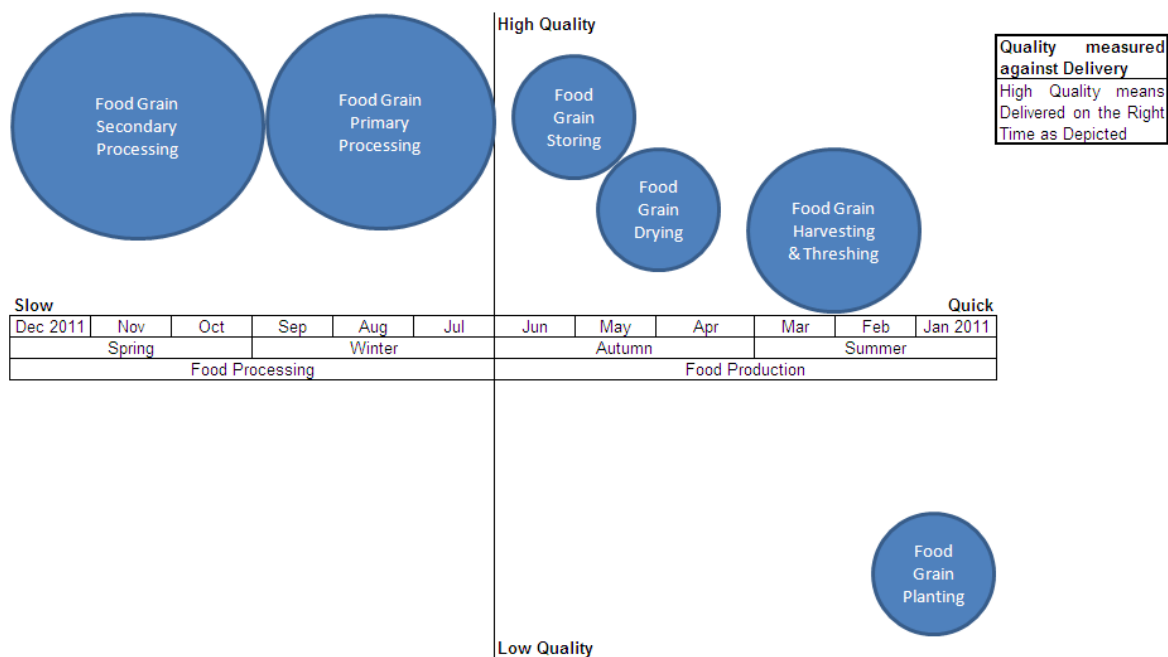

Figure 79: Market Positioning - Grain/Food Production and Processing Programmes

Although market positioning (Figure 79) is no part of the modified product design method template (Expression 19, Expression 20 and Figure 62), it gives the perspectives for, or an understanding of, the transitions that are designed into products. The Customer Domain established the Customer Needs (Figure 64); the Analytical Kano Model gave an idea of the whereabouts of the Competitive Products (Figure 66); the Quality Ladder (Figure 75) provides the technology diffusion pattern (Figure 74), the Market Positioning (Figure 79) will be used to develop competitive maps for the ISPAAD and YFF. A competitive map documents the key buying criteria for each market segment, analyses and ranks the competitors and finally it informs the market positioning map. The grain planting products when delivered in 2011 would find the summer rains over therefore it is not likely to benefit from this study (unless if it is used for irrigation fields – which are not covered by ISPAAD).

It must be recalled that the technical performance variables that are used for the competitive maps can be both intensive and extensive. The performance of ISPAAD

and YFF are related to weather conditions in Botswana. The technical performance variables related to weather are extensive. Demand management can be useful for influencing or addressing these extensive weather technical performance variables by providing product types sequenced to avoid quality hazards due to the weather elements on crops whilst improving agricultural productivity. Additional capacity might be required at different time periods for food production activities during the summer and autumn seasons but it will also be freed at spring and winter for food processing. For example, most of the technological limits as documented in the National Policy on Agricultural Development (Government of Botswana, 1991) such as the pricing systems, unproductively, lack of diversification and non-targeted use of Government Subsidies may be addressed by influencing the demand for the ISPAAD and YFF products by customers or clients; for example, the price may be dropped to encourage certain agricultural activities.

In this study, demand management would be through postponement strategy: a postponement strategy aims at delaying some supply chain activities (i.e. the YFF) until customer demand (i.e. ISPAAD) is revealed in order to maintain both low system-wide cost and fast response.

A value chain has five major stages all of which happen within a company: inbound logistics, operations, outbound logistics, marketing and sales as well as service (Porter, 1985). For this study, YFF Value Chain would be geared towards servicing the ISPAAD Value Chain (Figure 80). For the YFF Value Chain, the inbound logistics would mainly be purchasing of raw materials, the operations would normally be manufacturing of physical products as designed in this study, outbound logistics would mainly be storage, light manufacturing and delivery at an institutional distribution centre. The scope for this study covers technology development RSTI activities (Section 4.3.3.1). The RSTI activities are absorbed as overhead cost of both YFF and ISPAAD.

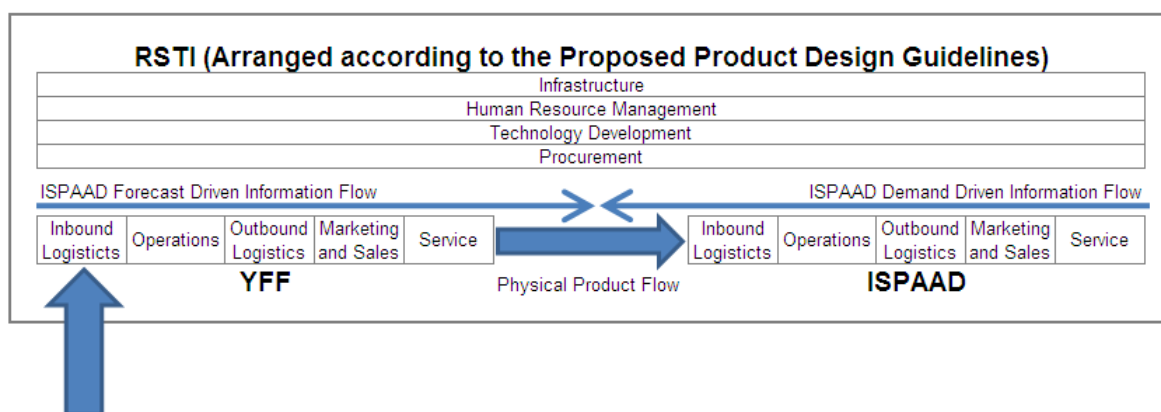

Figure 80: YFF and ISPAAD Value Chain

There are four types of postponement strategies:

1. Purchasing Postponement: Delay purchasing of some expensive and fragile materials (Figure 81).

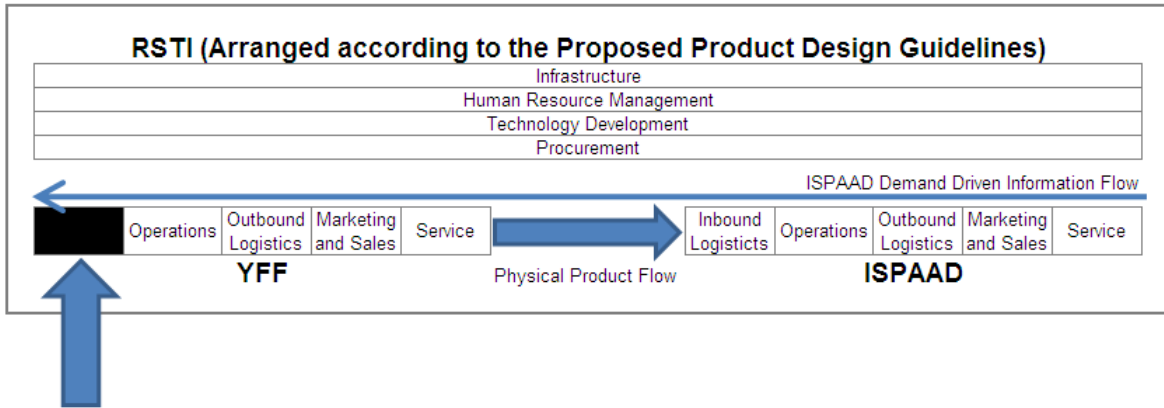

Figure 81: Purchasing Postponement (Note the suppression of Inbound Logistics and ISPAAD Forecast Driven Information Flow)

2. Manufacturing Postponement: Products in semi-finished forms and can be customized quickly in production facilities (Figure 82)

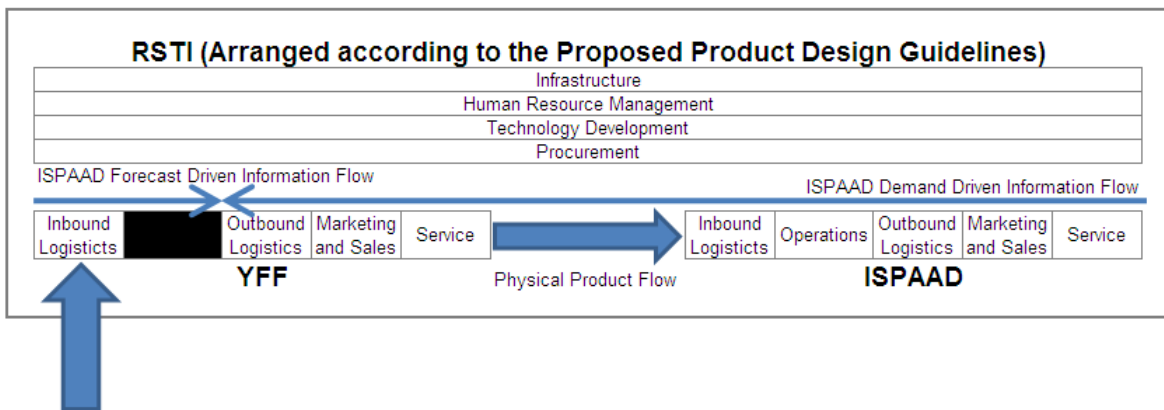

Figure 82: Manufacturing Postponement (Note the suppression of Operations)

3. Logistics Postponement: Products in semi-finished forms and can be customized quickly in production facilities close to customers (Figure 83).

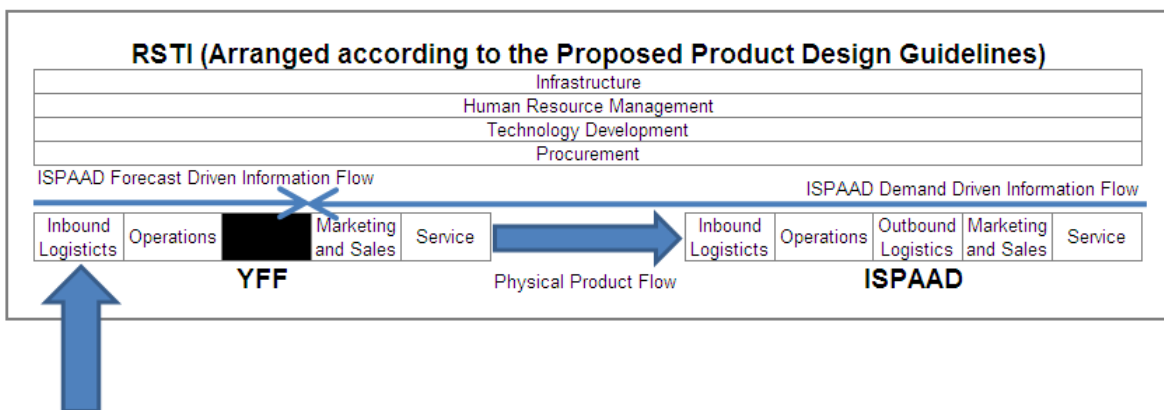

Figure 83: Logistics Postponement (Note the suppression of Outbound Logistics)

4. Time Postponement: Finished products are kept in central location and are distributed quickly to customers (Figure 80).

The ISPAAD products should be of modular and standardised product design for high products variety.

The ISPAAD products must be designed to real time synchronisation of the demand driven information flow with the forecast driven information flow. The institutional distribution centres or industrial districts would have to provide fast response inbound and outbound logistics as well as stronger relationships among themselves to support the two programmes, and the supplier of raw materials to both programmes (Ideally the YFF should provide all raw materials required by ISPAAD and YFF may be supplied TWDNSTT).

Lee and Billington (n.d.) introduce the level of postponement as the relative location of the point of product differentiation. In this study the level of postponement must be aligned with the quality ladder (Figure 75) and the market positioning (Figure 79). Market positioning is what the customers think of the product; for example, the mental picture of ISPAAD during the summer season, should be the knowledge that that the grain planting products are ready and have been delivered by the YFF. The mental picture of the YFF should be the level of postponement; the job descriptions of the design professionals at the RSTI must be such as to provide an enabling support to both the market positioning and level of postponement. With respect to this study, the approach suggested by Lee and Billington (n.d.) essentially looks at the operations and outbound logistics which are both sub-divided in to five core stages called the “product variety proliferation tree” (Figure 84): manufacturing, integration, customization, localisation and packaging.

1. Manufacturing refers to the stage where the product platform is made;
2. Integration refers to the stage where the product platform is combined with key sub-assemblies. Integration results in different product derivatives;
3. Customisation refers to the stage where the product derivatives are combined with accessories to result in distinct product choices;
4. Localisation refers to the stage where the product choices are localised to suit local requirements of geographical regions.

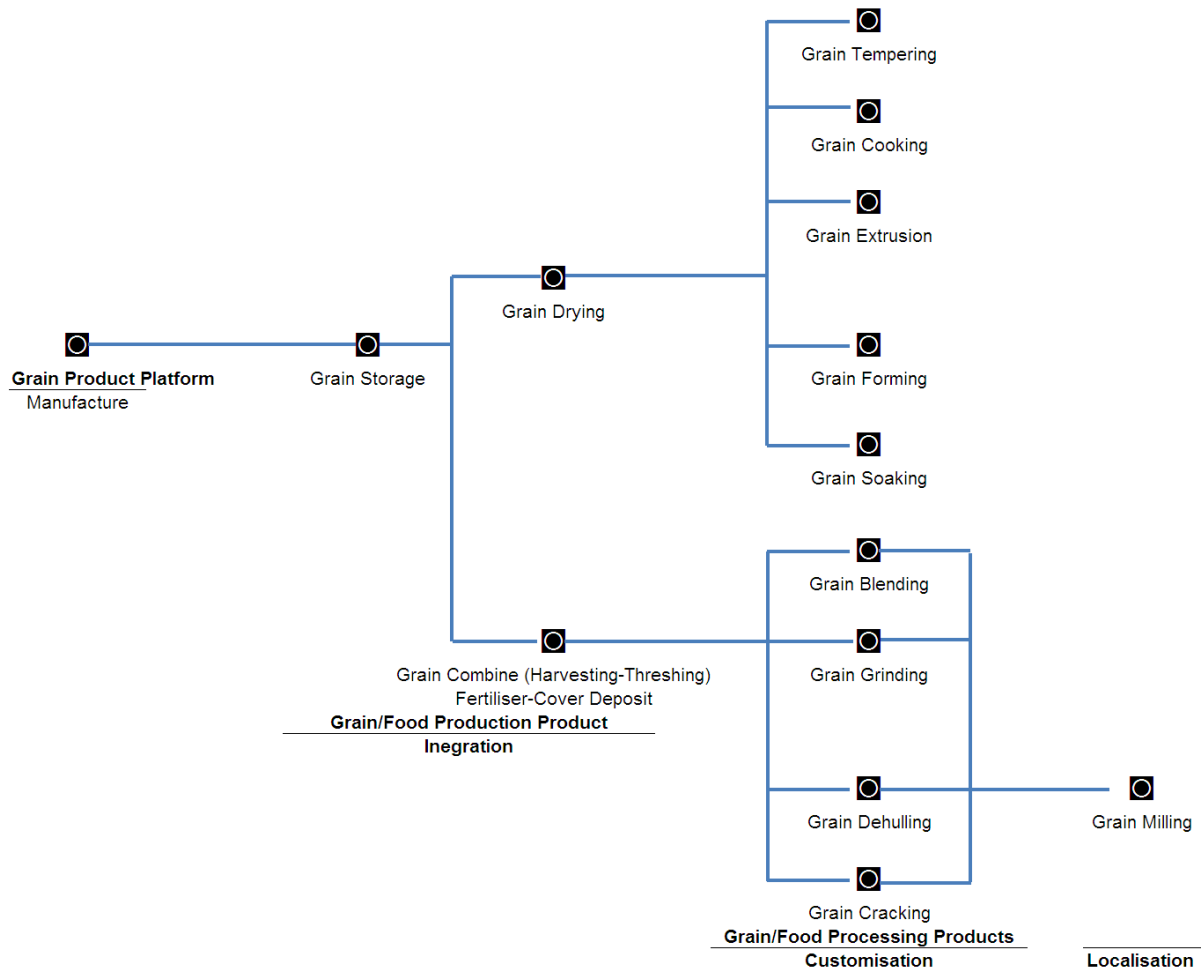

Figure 84: ISPAAD and YFF Demand Management - Product Variety Proliferation Tree

All these levels of postponement, when design into products, allow the effective and efficient use of industrial district covering a wide geographical area. Industrial districts require manpower with well crafted job description (Appendix 8).

6.3.1.2.2 Design Rule 6 and the Calculation of the Technical Productivity:

The Customer Domain was used to develop the engineering characteristics from the relational matrix of the house of quality (Figure 85). The relationship between the engineering characteristics may be established through dimensional analysis.

or check relations among physical quantities by using their dimensions. The dimension of a physical quantity is the combination of the basic physical dimensions which describe it which, in this study, is the basic physical dimension of the Metric System of Units.

Choice of Physical Quantities			Metric System of Basic Units			
Function	Flow	Quantity	Quantity	Units	Dimensions	Metric
Import or Channel	Energy	Resistance	Mass	Kilogram	M	kg
	Material	Area	Length	metre	L	m
Actuate	Energy	Torque , Joule	Time	second	T	s
	Material	Torque	Electric Current	Ampere	I	A
Regulate	Energy	Voltage	Absolute Temperature	Kelvin	K	K
	Material	Mass Flowrate	Luminous Intensity	candela	cd	cd
Convert	Energy	$E = mc^2$				
	Material					
Transmit	Energy	Power				
	Material	Force				
Store	Energy	Potential Energy				
	Material	Volume				
Separate or Refine	Energy	Energy Conversion				
	Material	Mass				

Table 29: Physical Quantities and Basic Physical Dimensions in the Metric System of Units

Buckingham II theorem was used to develop physically meaningful equation. The procedure for the theorem may be divided into five steps:

1. List all the variables that govern the process. These variables should be independent of each other (Table 30).

Dimensions	Metrics	Variables	Descriptions
$[MLT^{-2}]$	N	$F_{\text{furrow-opening}}$	Force for Opening the Furrow
[L]	m	$d_{\text{soil-excavate}}$	Depth of Furrow
$[L^2]$	m^2	$A_{\text{seed-opening}}$	Area of Seed Storage Opening
$[L^3]$	m^3	$V_{\text{seed-storage}}$	Volume of Stored Seeds
$[T^{-1}]$	Hz	$\omega_{\text{seed-deposit}}$	Frequency of Seeds Depositing
$[ML^{-2}]$	kg/m^2	$\mu_{\text{seed-population}}$	Average Seed Population per Unit Area
$[L^3]$	m^3	$V_{\text{seed-soil-cover}}$	Volume of Seed Covering Soil
$[L^2]$	m^2	$A_{\text{fertiliser-opening}}$	Area of Seed Storage Opening
$[L^3]$	m^3	$V_{\text{fertiliser-storage}}$	Volume of Stored Fertiliser
$[T^{-1}]$	Hz	$\omega_{\text{fertiliser-deposit}}$	Fertiliser Feedrate
$[ML^{-2}]$	kg/m^2	$m_{\text{fertiliser-population}}$	Average Mass of Fertiliser per Unit Area
$[L^3]$	m^3	$V_{\text{fertiliser-soil-cover}}$	Volume of Fertiliser Covering Soil
$[MLT^{-2}]$	N	$F_{\text{soil-compaction}}$	Force for Compacting the Soil after Covering

Table 30: Dimensions, Metrics Variable and Descriptions of Engineering Characteristics for the Grain Planting Product

2. Mark the repeating variables and decide how many non-dimensional numbers are there (Table 31).

Dimensions	Recurring Variables
[MLT ⁻²]	F _{furrow-opening}
[L]	d _{soil-excavate}
[T ⁻¹]	ω _{seed-deposit}

Number of Variables: 13

Number of Fundamental Units: 3 [M],[L] and [T]

Number of Dimensionless Groups: 10

Table 31: Recurring Variables for the Grain Planting Product

- Define the non-dimensional numbers by grouping the variables so that each group has all the repeating variables and one non-repeating variable (Equation 23).

$$\begin{aligned} \pi_1 &= \frac{A_{\text{seed-opening}}}{(d_{\text{soil-excavate}})^2} & \pi_4 &= \frac{A_{\text{fertiliser-opening}}}{(d_{\text{soil-excavate}})^2} & \pi_7 &= \frac{\mu_{\text{seed-population}} d_{\text{soil-excavate}} (\omega_{\text{seed-deposit}})^2}{F_{\text{furrow-opening}}} \\ \pi_2 &= \frac{V_{\text{seed-storage}}}{(d_{\text{soil-excavate}})^3} & \pi_5 &= \frac{V_{\text{fertiliser-storage}}}{(d_{\text{soil-excavate}})^3} & \pi_8 &= \frac{m_{\text{fertiliser-population}} d_{\text{soil-excavate}} (\omega_{\text{seed-deposit}})^2}{F_{\text{furrow-opening}}} \\ \pi_3 &= \frac{V_{\text{seed-soil-cover}}}{(d_{\text{soil-excavate}})^3} & \pi_6 &= \frac{V_{\text{fertiliser-soil-cover}}}{(d_{\text{soil-excavate}})^3} & \pi_9 &= \frac{\omega_{\text{fertiliser-deposit}}}{\omega_{\text{seed-deposit}}} \\ & & & & \pi_{10} &= \frac{F_{\text{soil-compaction}}}{F_{\text{furrow-opening}}} \end{aligned}$$

Equation 23: Engineering Formulae for Gran Planting Product

- From which the following equations are developed (Equation 24):

$$\pi_8 \propto (\pi_1, \pi_2, \pi_3, \pi_4, \pi_5, \pi_6, \pi_7, \pi_9, \pi_{10})$$

$$m_{\text{fertiliser-population}} \propto \frac{A_{\text{seed-opening}} V_{\text{seed-storage}} V_{\text{seed-soil-cover}} A_{\text{fertiliser-opening}} V_{\text{fertiliser-storage}} V_{\text{fertiliser-soil-cover}} \mu_{\text{seed-population}} \omega_{\text{fertiliser-deposit}} F_{\text{soil-compaction}}}{F_{\text{furrow-opening}} (d_{\text{soil-excavate}})^{14} \omega_{\text{seed-deposit}}}$$

$$\pi_7 = \frac{\mu_{\text{seed-population}} d_{\text{soil-excavate}} (\omega_{\text{seed-deposit}})^2}{F_{\text{furrow-opening}}}$$

$$F_{\text{furrow-opening}} \propto \mu_{\text{seed-population}} d_{\text{soil-excavate}} (\omega_{\text{seed-deposit}})^2$$

$$\pi_8 = \frac{m_{\text{fertiliser-population}} d_{\text{soil-excavate}} (\omega_{\text{seed-deposit}})^2}{F_{\text{furrow-opening}}}$$

$$F_{\text{furrow-opening}} \propto m_{\text{fertiliser-population}} d_{\text{soil-excavate}} (\omega_{\text{seed-deposit}})^2$$

Equation 24: π Equations

The same procedure was also used for the product variety proliferation tree (Figure 84):

1. List all the variables that govern the process. These variables should be independent of each other (Table 32).

	Dimensions	Metrics	Variables	Descriptions
Power Module	[Ohm] or [L ²]	Ω or m ²	Ω _{imported-energy} or A _{imported-energy}	Resistance of Conductor or Area of Lid Opening to Imported Energy (from a Power Source such as Petrol, Diesel, Electrical Mains/Socket)
	[ML ² T ⁻²]	Nm	τ _{actuated-energy}	Torque required to Turn the Switch or Lid
	[V] or [MT ⁻²]	V or kg/s ²	V _{regulated-energy} ṁ _{regulated-chemical-fuel}	Voltage of Electric Energy or Mass Flowrate of Energy Source
	[ML ² T ⁻²]	J	E _{converted-energy}	Energy Converted
	[ML ² T ⁻³]	W	P _{transmitted-power}	Power Transmitted
	[L ²]	m ²	A _{lever-human}	Area of Lever impinged upon by Human Being
Processing Module	[L ²]	m ²	A _{solid-opening}	Area of Opening through which the Solid passes
	[L ³]	m ³	Φ _{stored-solid-unregulated}	Volume of Stored Solid in the Hopper
	[MLT ⁻²]	N	F _{unrefined-solid}	Force required to move the UnRefined Solid
	[MT ⁻²]	kg/s ²	ṁ _{regulated-solid}	Mass Flowrate of the Solid
	[L ³]	m ³	Φ _{stored-solid-regulated}	Volume of Stored Solid within the Machine as it is being Refined
	[M]	kg	μ _{refined-solid}	Mass of Separated Solid Components (Refined Solid and By-Products)
Aeration Module	[L ²]	m ²	A _{gas-fan}	Area of Fan Opening through which the Gas passes
	[L ²]	m ²	A _{solid-channel}	Area of Opening through which the Refined Solid passes
Separation Module	[MLT ⁻²]	N	F _{refined-solid}	Force required to move the Refined Solid (may be as Fraction of the Total Force for the UnRefined Solid)
	[M]	kg	μ _{separated-solid}	Mass of Separated Solid Components (Refined Solid and By-Products)

Table 32: Dimensions, Metrics Variable and Descriptions of Physical Quantities for the product variety proliferation tree

2. Mark the repeating variables and decide how many non-dimensional numbers are there (Table 33).

Dimensions	Recurring Variables
[ML ² T ⁻²]	E _{converted-energy}
[MT ⁻²]	ṁ _{regulated-chemical-fuel}
[M]	μ _{separated-solid}
Number of Variables: 16	
Number of Fundamental Units: 3 [M],[L] and [T]	
Number of Dimensionless Groups (π): <u>13</u>	

Table 33: Recurring Variables for the Product Platform

3. Define the non-dimensional numbers by grouping the variables so that each group has all the repeating variables and one non-repeating variable (Equation 25).

Power Module	$\pi_1 = \frac{\dot{m}_{\text{regulated-chemical-fuel}}}{E_{\text{converted-energy}}} A_{\text{imported-energy}}$	Aeration Module	$\pi_{11} = \frac{\dot{m}_{\text{regulated-chemical-fuel}}}{E_{\text{converted-energy}}} A_{\text{gas-fan}}$
	$\pi_2 = \frac{T_{\text{actuated-energy}}}{E_{\text{converted-energy}}}$		$\pi_{12} = \frac{\dot{m}_{\text{regulated-chemical-fuel}}}{E_{\text{converted-energy}}} A_{\text{solid-channel}}$
	$\pi_3 = \frac{P_{\text{transmitted-power}}}{E_{\text{converted-energy}}} \left(\frac{\mu_{\text{separated-solid}}}{\dot{m}_{\text{regulated-chemical-fuel}}} \right)^{1/2}$		$\pi_{13} = \frac{F_{\text{refined-solid}}}{E_{\text{converted-energy}} \dot{m}_{\text{regulated-chemical-fuel}}}$
	$\pi_4 = \frac{\dot{m}_{\text{regulated-chemical-fuel}}}{E_{\text{converted-energy}}} A_{\text{lever-human}} \quad (= \pi_1)$		Separation Module
Processing Module	$\pi_5 = \frac{\dot{m}_{\text{regulated-chemical-fuel}}}{E_{\text{converted-energy}}} A_{\text{solid-opening}} \quad (= \pi_1 = \pi_4)$		
	$\pi_6 = \frac{\dot{m}_{\text{regulated-chemical-fuel}}}{E_{\text{converted-energy}}} \left(\phi_{\text{stored-solid-unregulated}} \right)^{2/3} \quad (= (\pi_1)^{1.5} = (\pi_4)^{1.5} = (\pi_5)^{1.5})$		
	$\pi_7 = \frac{F_{\text{unrefined-solid}}}{E_{\text{converted-energy}} \dot{m}_{\text{regulated-chemical-fuel}}}$		
	$\pi_8 = \frac{\dot{m}_{\text{regulated-solid}}}{\dot{m}_{\text{regulated-chemical-fuel}}}$		
	$\pi_9 = \frac{\dot{m}_{\text{regulated-chemical-fuel}}}{E_{\text{converted-energy}}} \left(\phi_{\text{stored-solid-regulated}} \right)^{2/3} \quad (= \pi_6)$		
	$\pi_{10} = \frac{\mu_{\text{refined-solid}}}{\mu_{\text{separated-solid}}}$		

Equation 25: Engineering Formulae for the Product Platform

The energy balance and mass balance equations (Equation 26) derived directly from the block flow diagram:

	Energy Balance Equations	
Input Energy	= In-Between Functional Energy	= Output Energy
	$E_{\text{supply}} = E_{\text{power-module}} + E_{\text{processing-module}} + E_{\text{aeration-module}} + E_{\text{separation-module}}$	$= E_{\text{heat}} + E_{\text{audio}} + E_{\text{vibration}}$
where	$E_{\text{power-module}} = E_{\text{imported-energy}} + E_{\text{lever-human}} + E_{\text{actuate-energy}} + E_{\text{regulated-energy}} + E_{\text{converted-energy}} + E_{\text{transmitted-energy}}$	
	$E_{\text{processing-module}} = E_{\text{imported-solid}} + E_{\text{stored-solid}} + E_{\text{transmitted-solid}} + E_{\text{regulated-solid}} + E_{\text{stored-solid}} + E_{\text{refined-solid}}$	
	$E_{\text{aeration-module}} = E_{\text{imported-gas}} + E_{\text{channel-refined-solid}}$	
	$E_{\text{separation-module}} = E_{\text{transmitted-refined-solid}} + E_{\text{separated-refined-solid}}$	
	$E_{\text{channel-refined-solid}} = E_{\text{imported-gas}} + E_{\text{refined-solid}}$	
	$E_{\text{regulated-solid}} = E_{\text{lever-human}} + E_{\text{transmitted-solid}}$	
	$E = MV^2$	
	(V = Velocity which is Generally far less than the Speed of Light for the Product being Designed)	
Input Mass	= In-Between Functional Mass	= Output Mass
	$M_{\text{solid}} + M_{\text{gas}} = M_{\text{processing-module}} + M_{\text{aeration-module}} + M_{\text{separation-module}}$	$= M_{\text{refined-solid}} + M_{\text{by-product}}$
where	$M_{\text{processing-module}} = M_{\text{imported-solid}} + M_{\text{stored-solid}} + M_{\text{transmitted-solid}} + M_{\text{regulated-solid}} + M_{\text{stored-solid}} + M_{\text{refined-solid}}$	
	$M_{\text{aeration-module}} = M_{\text{imported-gas}} + M_{\text{channelled-solid}}$	
	$M_{\text{separation-module}} = M_{\text{transmitted-refined-solid}} + M_{\text{separated-refined-solid}}$	
	$M_{\text{channel-refined-solid}} = M_{\text{regulated-solid}} + M_{\text{refined-solid}}$	
	$M_{\text{aeration-module}} = M_{\text{separated-module}}$	
	$V_{\text{solid}} + V_{\text{gas}} = \rho_{\text{solid}} M_{\text{solid}} + \rho_{\text{gas}} M_{\text{gas}}$	(at every Process Stage)

Work Package	Input		Output		Productivity
	ManHours	Consumption (P)	Physical	Market Value (P)	%
Load	104	15601.95	Analysis Reports and Technical Drawings	31203.90	100
Free Body Diagram	16	2400.30		4800.60	100
Static Loading	24	3600.45		7200.90	100
Dynamic Loading	24	3600.45		7200.90	100
Vibration	32	4800.60		9601.20	100
Impact Loading	8	1200.15		2400.30	100
Stress and Strain	48	7200.90		14401.80	100
Applied vs. Principal Stresses	16	2400.30		4800.60	100
Bending Stress	16	2400.30		4800.60	100
Deflection	8	1200.15		2400.30	100
Torsion	8	1200.15		2400.30	100
Failure	128	19202.40		38404.80	100
Static Failure	24	3600.45		7200.90	100
Ductile Materials	8	1200.15		2400.30	100
Brittle Materials	8	1200.15		2400.30	100
Fracture	8	1200.15		2400.30	100
Dynamic Failure	48	7200.90		14401.80	100
Fatigue	8	1200.15		2400.30	100
Stress Concentrations	24	3600.45		7200.90	100
Residual Stresses	16	2400.30		4800.60	100
Surface Failure	56	8401.05		16802.10	100
Friction	8	1200.15		2400.30	100
Wear	24	3600.45		7200.90	100
Spherical / Cylindrical Contact	24	3600.45		7200.90	100
Energy	88	13201.65		26403.30	100
Forms of Energy	16	2400.30		4800.60	100
Energy Transfer and Transformation	32	4800.60		9601.20	100
Virtual Work	40	6000.75		12001.50	100
Sales and Marketing	80	12001.50		9601.20	-20
Marketing Strategy	32	4800.60		9601.20	100
Advertising	16	2400.30		0.00	-100
Branding	16	2400.30		0.00	-100
Sales Forecasting	16	2400.30		0.00	-100
Risk	128	19202.40	7200.90	-62.5	
Identification	72	10801.35	0.00	-100	
Source Analysis	24	3600.45	0.00	-100	
Problem Analysis	32	4800.60	0.00	-100	
Scenario-Based	8	1200.15	0.00	-100	
Risk Chart	8	1200.15	0.00	-100	
Assessment	56	8401.05	7200.90	#####	
Probability / Rate of Occurance	16	2400.30	0.00	-100	
Impact	16	2400.30	0.00	-100	
Risk Management Plan	24	3600.45	7200.90	100	
Cost	48	7200.90	9601.20	33.3333333	
Budget	32	4800.60	9601.20	100	
Variance Analysis	16	2400.30	0.00	-100	
Manufacture		6000.00	7980.00	33	
Material		2250.00	2992.50	33	
Machining		225.00	299.25	33	
Fabrication		3525.00	4688.25	33	
		99611.70	144797.10	45.4	

Table 34: Design Rule 6 - Sample of the Input and Output Analysis

6.3.1.2.3 Design Rule 7 and Specifications of Key Technologies

The Design Principle or Rule 7 is comprised of product design specifications (PDS) documentation inclusive of the design mapping models (Section 3.3). The PDS provides measurable description of what the product must accomplish and could be documented for lower levels of generality if necessary i.e. some product design activities may require sub-system design specifications (SSDS) and components design specification (CDS). The PDS, SSDS and CDS consist of the technical performance measures and target values or performance levels.

The PDS, SSDS and CDS may be developed from a checklist, in which case they will include other stakeholders or they may be presented in format that includes the house of quality (HoQ) to summarise the relationship between customer needs and engineering characteristics, check for conflicts in the specification as well as documenting the benchmarking information and technical difficulty. The HoQ is particularly helpful for SSDS and CDS because it focuses only on what the customers, as a subset of all the other stake-holders such as funding institutions.

Figure 87 shows the PDS developed for the industrial case application examined in this research; its presentation may be broken down as follows:

1. Problem Re-Formulation which comprises of equations or inequalities derivable from Design Principle or Rule 6;
2. Relevant Standards which identifies all international standards that affect the product and may include excerpts from these standards;
3. List of all the sub-systems of the product, project or programme. The Design Principles or Rules 1 to 6 may be regarded as necessary preparatory activities or indeed they may be considered to be part of the elements of the PDS (Figure 88); each product, project or programme accompanied by relevant requirements or elements of the PDS (Figure 87). Requirements would identify a capability, physical characteristic, or quality factor that bounds a product or process need for which a solution will be pursued (IEEE Standard 1220 – 1994). The requirements could be described as mandatory and utility (or helpful) and there would be three types of requirements: Performance, Functional and Constraints (Evans, 2000). Requirements should be assessed for their feasibility, ambiguity, completeness, testability and simplicity (abbreviated to FACTS) and should at least answer the W⁵H questions of who, what, where, when, why and how; hence, they may be regarded It would be seen that Figure 87 concentrated only on product performance and some aspects of the environment. The requirements development activities could be a stand-alone project (Dean et al, 1997).
4. List of any auxiliary products with a house of quality (HoQ) for some sub-systems. Figure 89 shows the HoQ for the planter.

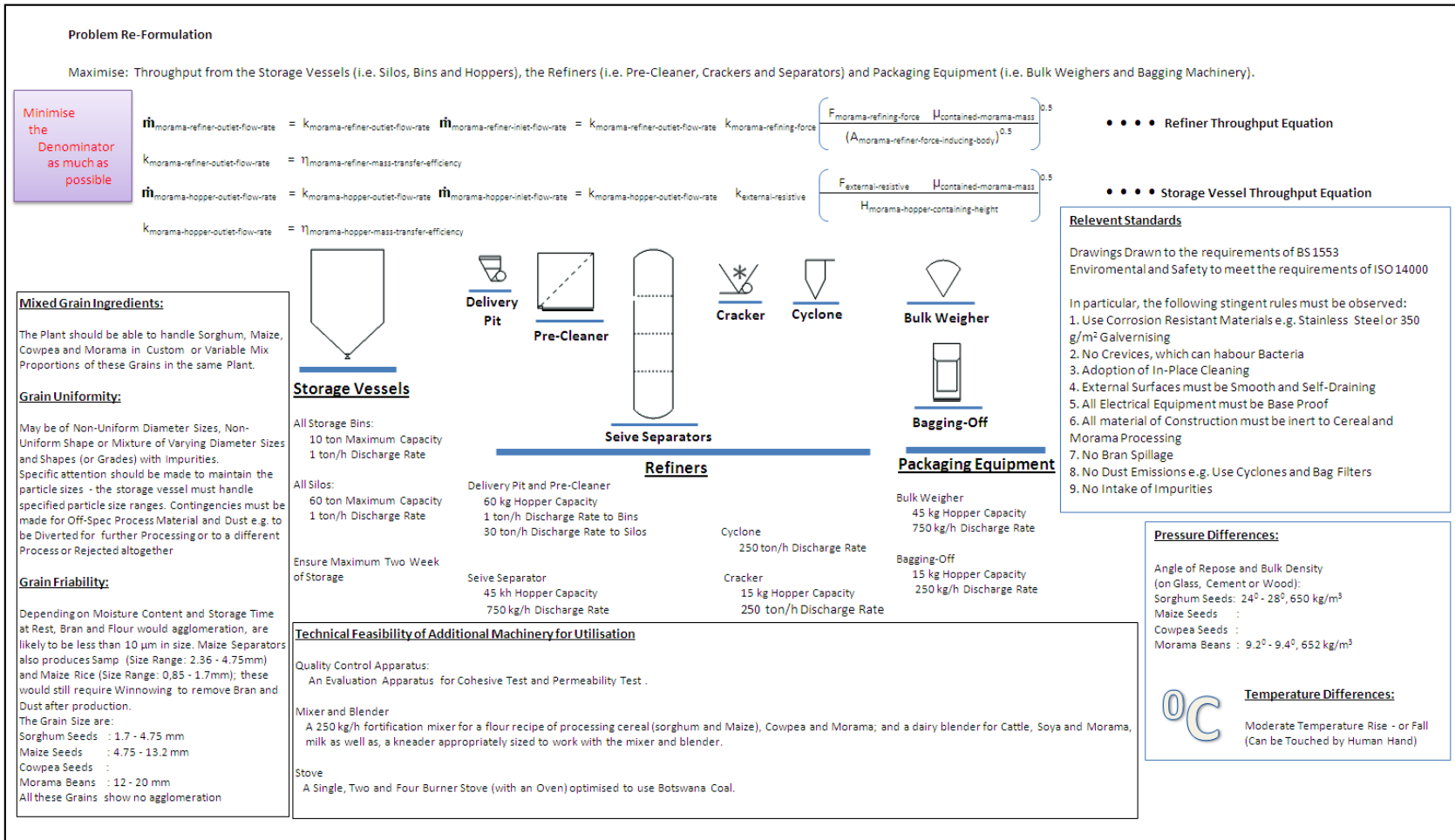

Figure 87: Sample PDS of the Industrial Case Applications Programme

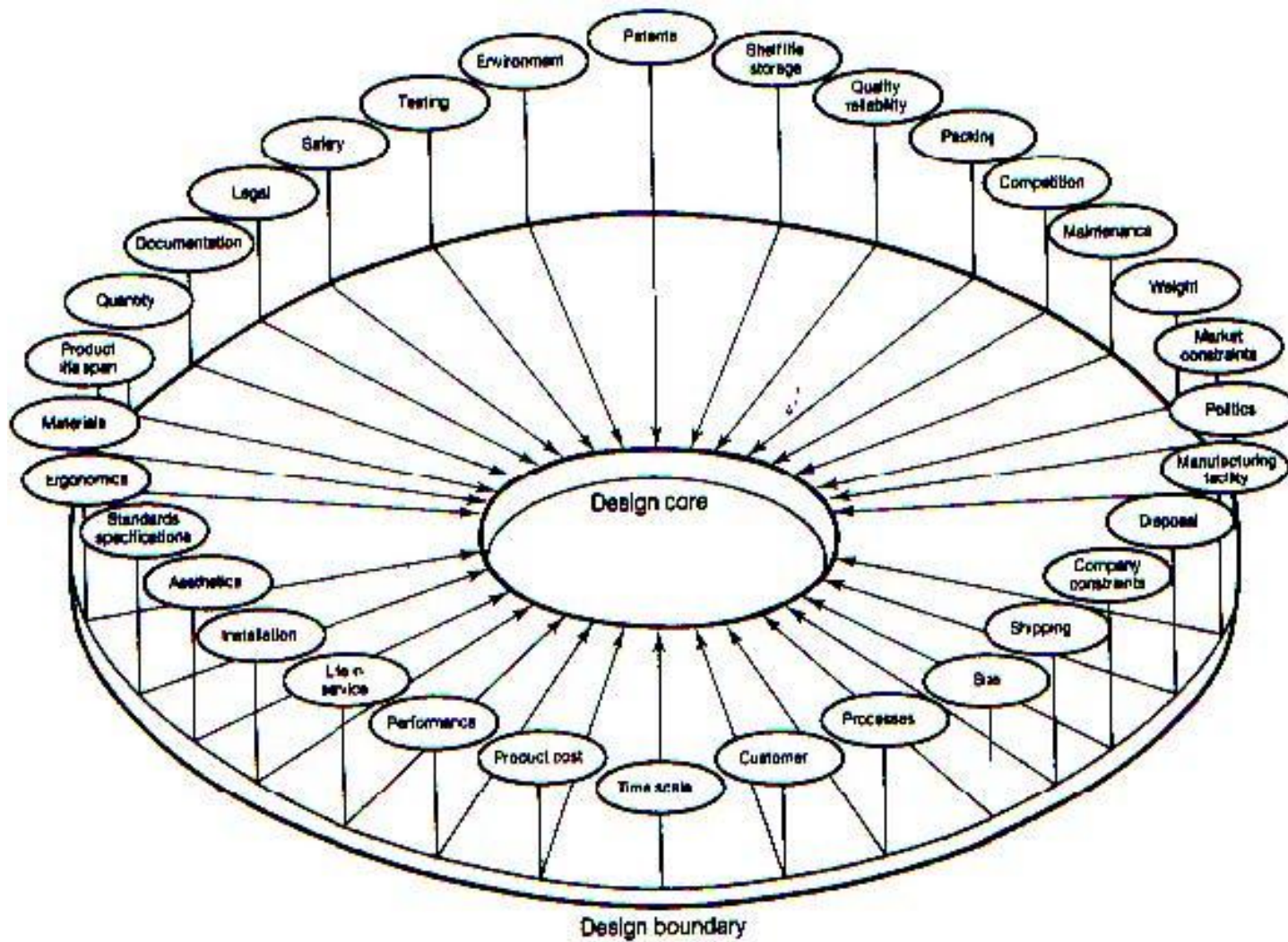

Figure 88: Elements of the PDS (Source: Pugh, 1991)

		Wheel Axle Distance from the Tractor Force Applicators	Force required to drive the Seed Mechanism	Force required to Mark Rows	Power required to Drive the entire Planter	Weight of the Planter	Power required to drive the Seed Mechanism	Time taken to Clean the Planter	Field Slope	Inter-row spacing of seeds	Holding Capacity for Seeds	Planting Speed of Travel	Height seed container from ground level	Size of Seeds to be planted	Distribution quantity for the fertiliser	Holding Capacity for fertiliser	Double Row Tractor Drawn Planter Mark I	Double Row Tractor Drawn Planter Mark II	South African Wonder
Seed Metering	4	7	10	1	7	3	10	5	7	10	10	7	7	10	1	1	3	27	15
Parallel Rows	5	4	1	10	7	3	1	1	7	1	1	7	1	1	1	1	15	21	6
Easy to Clean	3	1	1	1	1	3	1	10	1	3	3	3	1	3	3	3			
Robust	3	7	7	7	7	7	7	2	6	1	1	8	2	1	1	1	9	4	6
Power Requirements	2	10	10	10	10	8	10	1	7	3	5	8	1	1	6	7			
Diversity of Seeds	5	3	6	1	4	4	6	3	5	9	10	7	3	10	6	6			
Compact	3	6	6	6	6	5	4	5	4	2	4	4	8	6	6	6	2	8	5
Operation	2	2	6	6	6	5	6	8	7	2	6	6	6	5	6	6			
Diversity of Fertilisers	5	2	2	2	5	1	3	5	6	4	1	4	1	2	10	10			
Percentage		6.512	7.597	6.822	8.217	6.047	7.442	6.202	7.752	5.426	6.357	8.372	4.651	6.047	6.202	6.357			
Technical Difficulty		1	4	1	7	6	6	4	4	2	2	6	4	3	5	2			
Measurement Units		m	N	N	kW	kg	kW	s	°	m	m ³	km/h	m	m	kg/Ha	m ³			
Target Values		1	0	0	23	100	0	300	5	0.2-0.4	0.06	5	0.5	0.02-0.16	200	0.12			

Figure 89: House of Quality for the Planter Product which is part of the G/FP&P – ITech Programme (as an example of the Sub-System Design Specifications)

6.3.2 Product Realisation

6.3.2.1 Design Rule 8

The Design Principle or Rule 8 is concerned with synthesis and evaluation of representation schemes of solutions i.e. combinations, putting together and building up of distinct components and sub-systems into a connected whole and to select the optimum to meet the product design specification; hence this design principle or rule is comprised of conceptual design inclusive of solution selection and detail design activities.

According to Pugh (1991), all products may be broken down from the total system or whole to the partial systems (i.e. the sub-systems and the component levels) as shown in Figure 90. Throughout the application of this principle or rule, there is extensive use of configuration sketches to represent the total, sub-systems and components levels. Typically, these configuration sketches of the products are called concept variants or solutions.

The generation of, or search for, solutions to meet the needs stated by the product design specification is called conceptual design; thus in this research, conceptual design purposefully does not include the preparation of product design specifications and is limited to the preparation of configuration sketches of concept variants and their selection thereof. It should be appreciated that conceptual design can be applied at the total system, sub-system and component level of a product but the total system must never be designed without a product design specification – this is because in some cases the product design specification of the total system takes care of both the sub-system and component level. The outcome of conceptual design is a set of configuration sketches representing the generated solutions.

The design mapping models (Section 3.3 and Section 5.3.1) demonstrate a transition or progression in the complexity of information recorded by the designer. It starts as a tree diagram of the customer needs, which is transformed into an activity diagram in transition into input – output concept diagram, block flow diagram, configuration sketches and finally into technical drawings; however, the generation of all these representation schemes is referred to as concept generation in literature. The configuration sketches are the usual form of representation scheme used to stand for concept variants. Detail design requires technical drawings which are then issued to the manufacturing workshop.

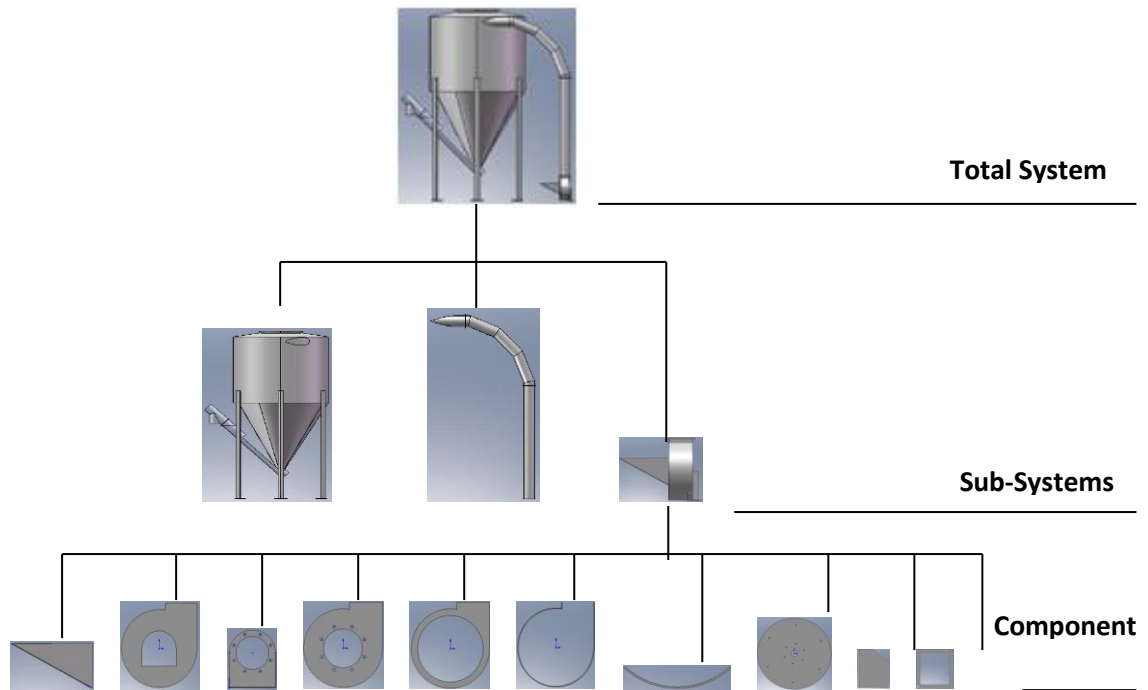

Figure 90: The Total, Sub-System and Component Levels of a Product represented through Configuration Sketches

6.3.2.1.1 Conceptual Design

Conceptual design has several stages as depicted in Figure 91 (Pahl and Beitz, 1996):

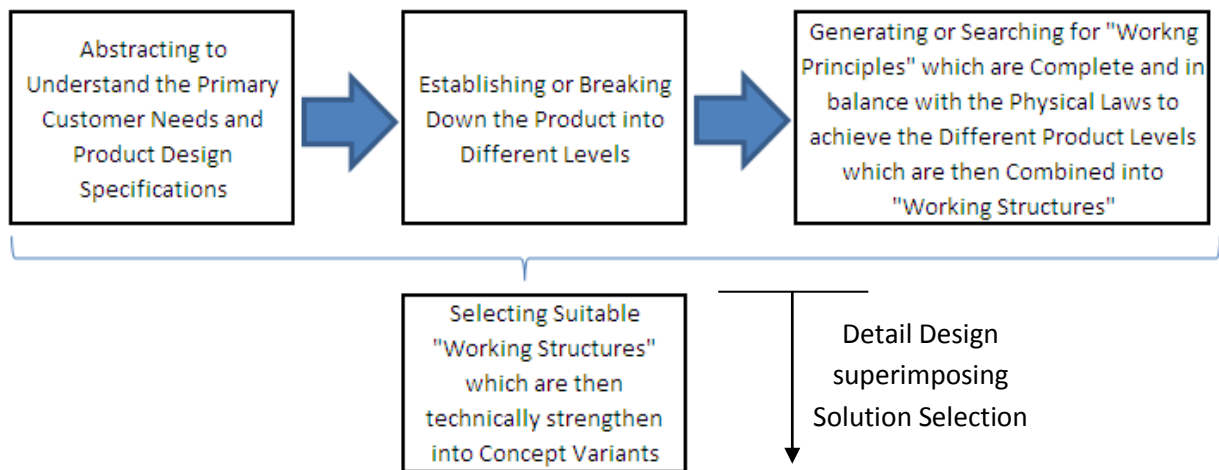

Figure 91: The Steps of Conceptual Design

Understanding Primary Customer Needs: The Design Principles or Rule 1 through 7 prepare for this first step of conceptual design. In this case study, the levels of postponement (Section 6.3.1.2.1) are used to identify the product required by the National Policy on Agricultural Development [NPAD] (Government of Botswana, 1991). The YFF and ISPAAD are its resultant programmes. In order to meet the objectives of the NPAD such as commercialisation of agriculture, the YFF may have the role of the supplier and the ISPAAD that of the customer. In such a set-up, the YFF would recognise a product as an item in the inventory awaiting an

order; whereas ISPAAD would recognise a product as a physical embodiment tool that satisfies the need for food production. The bulk storage bin was identified as a product platform by the proliferation tree developed through the application of the Design Principle or Rule 5.

Establishing the System, Sub-System and Component Levels of the Product:

Figure 90 shows the different breakdown functional levels for the bulk storage bin; these were first established functionally and the figures illustrate the final means of achieving the functions. The basic product constituent levels for the products in this case study were established during the application of the Design Principle or Rule 2 (Section 6.3.1.1.2).

Searching for “Working Principles” and Generating “Working Structures”

A number of “working principles” for sub-systems were searched for and combined to generate “working structures” (Figure 93 and 94). There are many methods used to search for “working principles” but those preferred for this case study work were the published media (journals, patents (Section 6.3.1.1.1), textbooks and product information), attribute listing, inversion, analogy, morphological analysis and TRIZ. The choice for using these creativity aiding methods was due to the fact that teamwork plays a crucial role in engineering product design; having to design alone, the researcher had to rely on these so called rational or directed methods.

In general, the sequence or cluster of creativity aid methods used in this research was as illustrated in Figure 92.

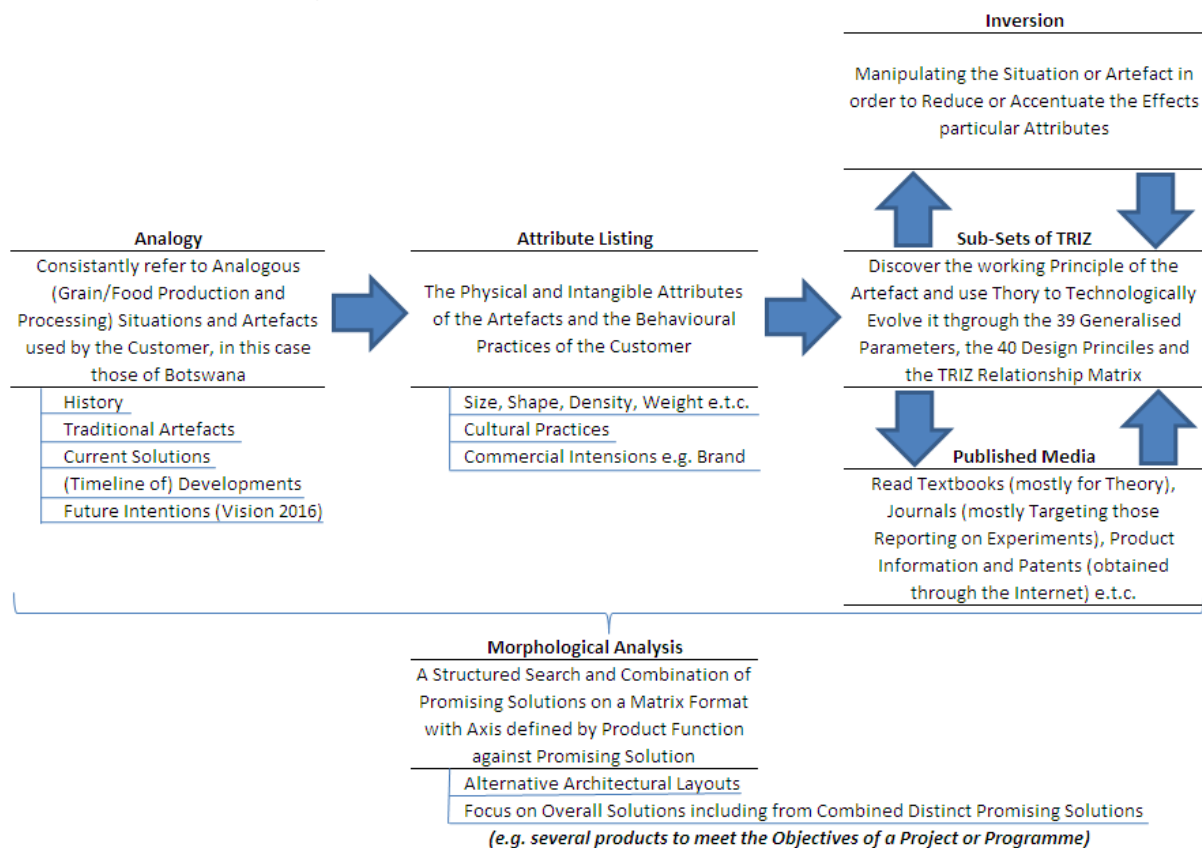
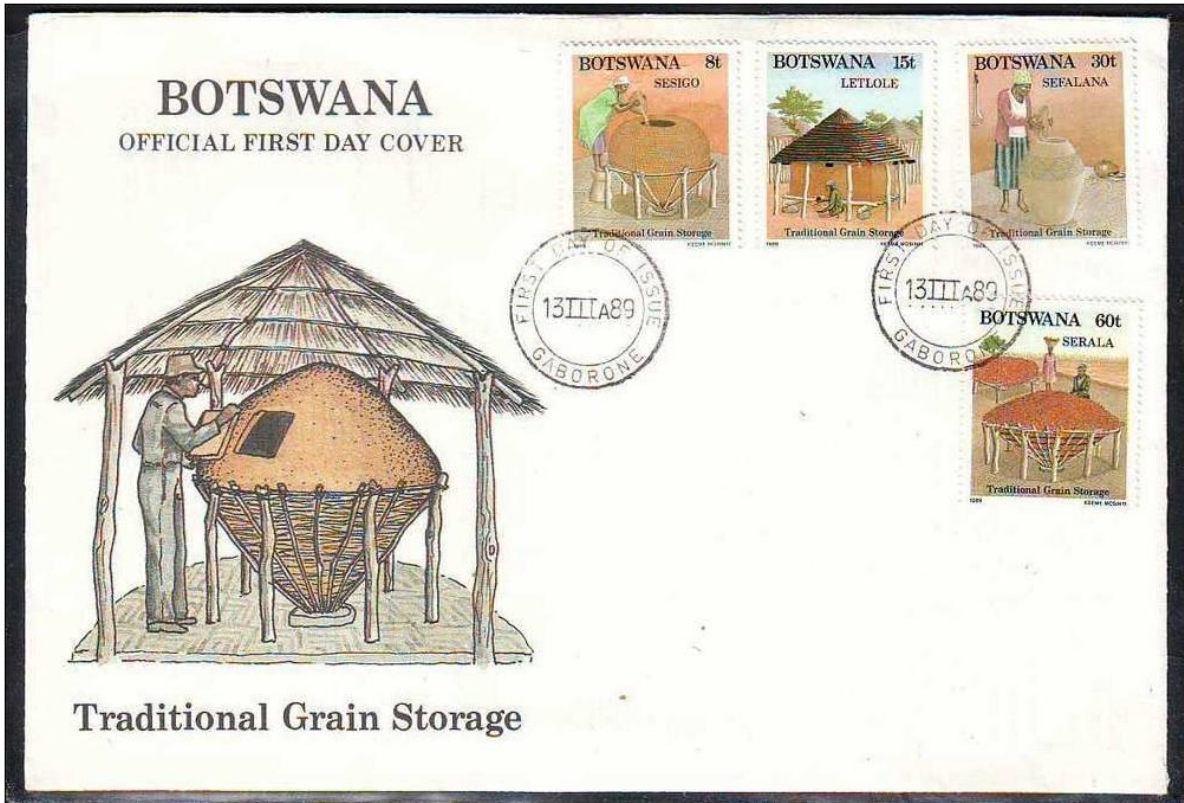
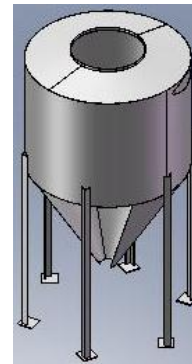
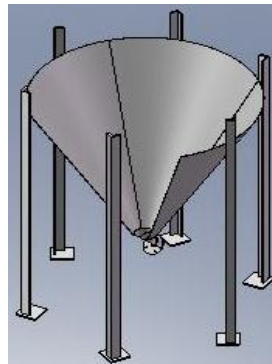
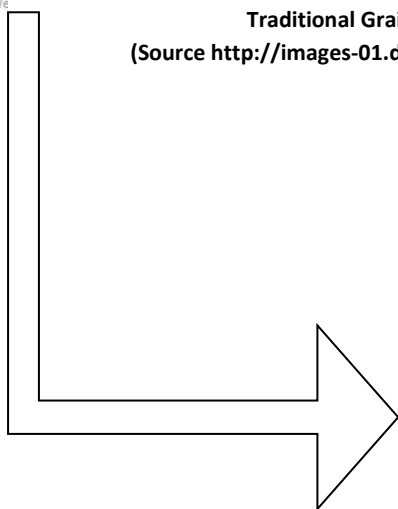

Figure 92: Sequence or Cluster of Creativity Aiding Methods



Traditional Grain Storage Artefact: Sesigo, Letlole, Sefalana and Serala
 (Source http://images-01.delcampe-static.net/img_large/auction/000/118/923/204_001.jpg)



Attribute Listing (Generation of a Transient Solution)

Concept Variant (Published Media)

Figure 93: Analogy and Attribute Listing based on Traditional Grain Storage Artifacts as recorded by Philpott and the Internet (Similarity with Serala) (Similarity with Sesigo)

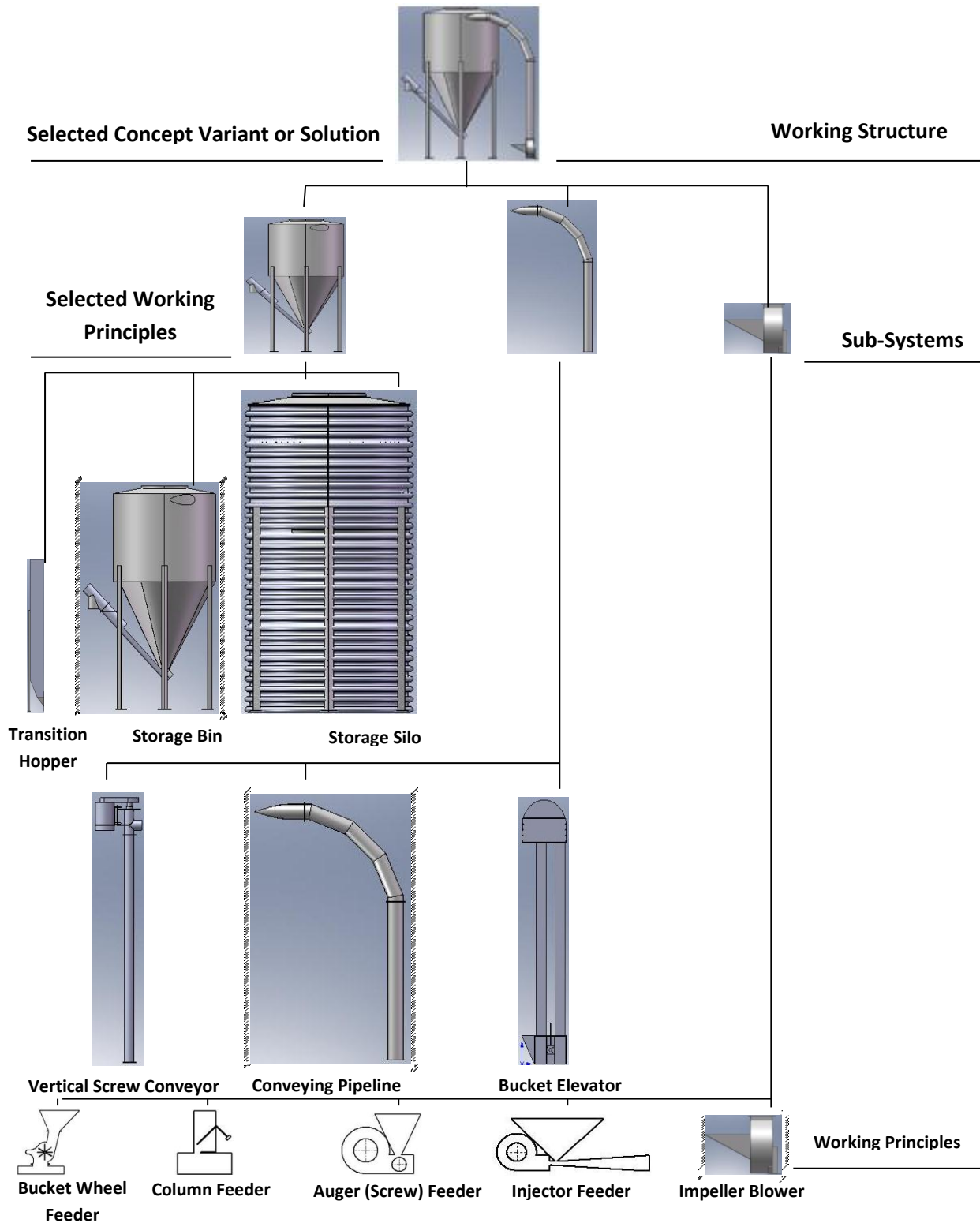

Figure 94: Working Principles (Working Principles from Published Media)

In this research, morphological analysis was applied to the search for products sub-systems and generation of a product family; the main objective would be the generation of a product family, which effectively would try to reduce the skill level of the designer to a mere selection of YFF suppliers. With this approach, a new and pivotal role of the suppliers to product design may be established (Griffin and Hauser, 1993; Ansari and Modaress, 1994; Prasad et. al, 2000).

Citing Zwicky (1948), Suh (1990) agrees that morphological analysis may be easily generalisable as it not for the fact that it does not involve concept selection. Tang et. al (2005) state that parts deployment, the second stage of QFD, is concerned not only with the determination of components or parts of a product but also with the technical parameters of the components or parts themselves against their functional and performance requirements; this explanation establishes the link between parts deployment and morphological analysis which is exploited in this research.

The quality ladder (Section 6.3.1.1.3) takes the shape of the proliferation tree established during the application of Design Principle or Rule 5 (Section 6.3.1.2.1) and is finally augmented into a morphological chart to capture the essence of the parts deployment³ (Table 35). This means that a common set of sub-systems must be used for the product family. This may be achieved through modular products.

Modular products provide improvements to product design by introducing many variants due to addition of sub-assemblies or modules to a product platform, to enable performance of different overall functions. Block flow diagrams that illustrate the overall function of a product by demarcating modules are referred to as function structures. When these modules represent physical sub-assemblies, the function structure then represents the product architecture. In as much as possible size ranges would be avoided to prevent cost escalation in design and production. The sub-assemblies should be produced by similar methods. The proliferation tree shows how this may be achieved and the process is further described below.

Table 35 shows the morphological analysis chart for the grain storage product which is considered as the product platform. The row heading lists the functions of the modules; the column headings list the sub-assemblies that may provide solutions to perform respective functions. The morphological analysis chart shows the same information as the working principles.

³ – it should be noted that the machinery intended for primary grain processing converts raw material in food commodity either through addition and/or extraction of water and heat only) and the bottom part denotes machinery intended for secondary processing (i.e. where the aim is to convert ingredients and may involve mixing or separating food commodities or part thereof)







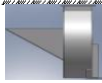
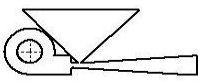
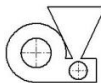

Sub-Functions	Sub-Assemblies				
Grain Feeder					
Convey Grain					
Store Grain					

Table 35: Morphological Analysis Chart for Grain Storage Product considered as the Product Platform (the Bold Boxes represent the Selected Sub-Assemblies)

		Food Grain Combine Harvester - Thresher	Food Grain Drier	Food Grain Primary and Secondary Processor
Energy		Petrol	Electricity	Electricity
		Noise	Noise	Noise
		Vibration	Vibration	Vibration
Solid		Heat	Heat	Heat
		Crop Head	Seed	Sorghum
		Chaff	Dust	Seed Kernels
Gas		By-Products	By-Products	By-Products
Power Module	Import Chemical or Electrical Energy	Air	Air	Air
	Actuate Chemical or Electrical Energy	Lid	Plug	Plug
	Regulate Chemical or Electrical Energy	Switch	Button	Button
	Convert Chemical or Electrical Energy to Mechanical Energy	Switch	Vari-Speed	Vari-Speed
	Transmit Mechanical Energy	Engine	Motor	Motor
	Import Human Force	Belt & Pulley	Belt & Pulley	Belt and Pulley
Processing Module	Import Solid			Lever
	Store Solid	Opening	Opening	Opening
	Transmit Solid	Hopper	Hopper	Hopper
	Regulate Solid	Door	Door	Door
	Store Solid			Lever
	Refine Solid	Concave (Seive)	Drum (Seive)	Concave (Trough)
Aeration Module	Import Gas	Drum (Spike)		Drum (Disc, Hammer, Flat Bar, Piston, Ribbon)
	Channel Refined Solid	Fan (Blower)	Fan (Blower)	Fan (Suction)
Separation Module	Transmit Refined Solid	Tray	Tray	Pipe and Spout
	Separate Refined Solid			Trough & Pipe
		Seive & Winnow	Seive	Cyclone

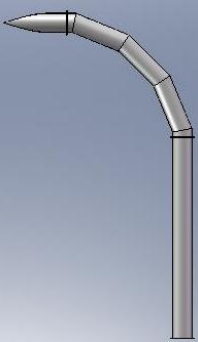
Table 36: Design Rule 2 - The Basic Functions of the Food Grain Harvester, Food Grain Thresher, Food Grain Dryer, Food Grain Primary and Secondary Processor

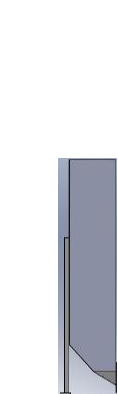
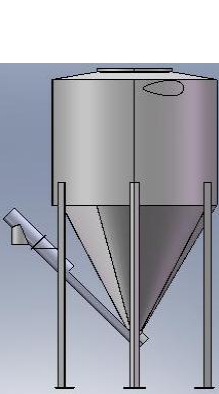
Table 36 shows the products as illustrated in the proliferation tree demonstrating the use of the common functional basis (Figure 69). The common basis greatly assists in having a common set of sub-assemblies that may be used in modular product

derivatives. The modules that are selected would become standard for the entire product family. This may be demonstrated by the top leg of the proliferation tree (Figure 95)

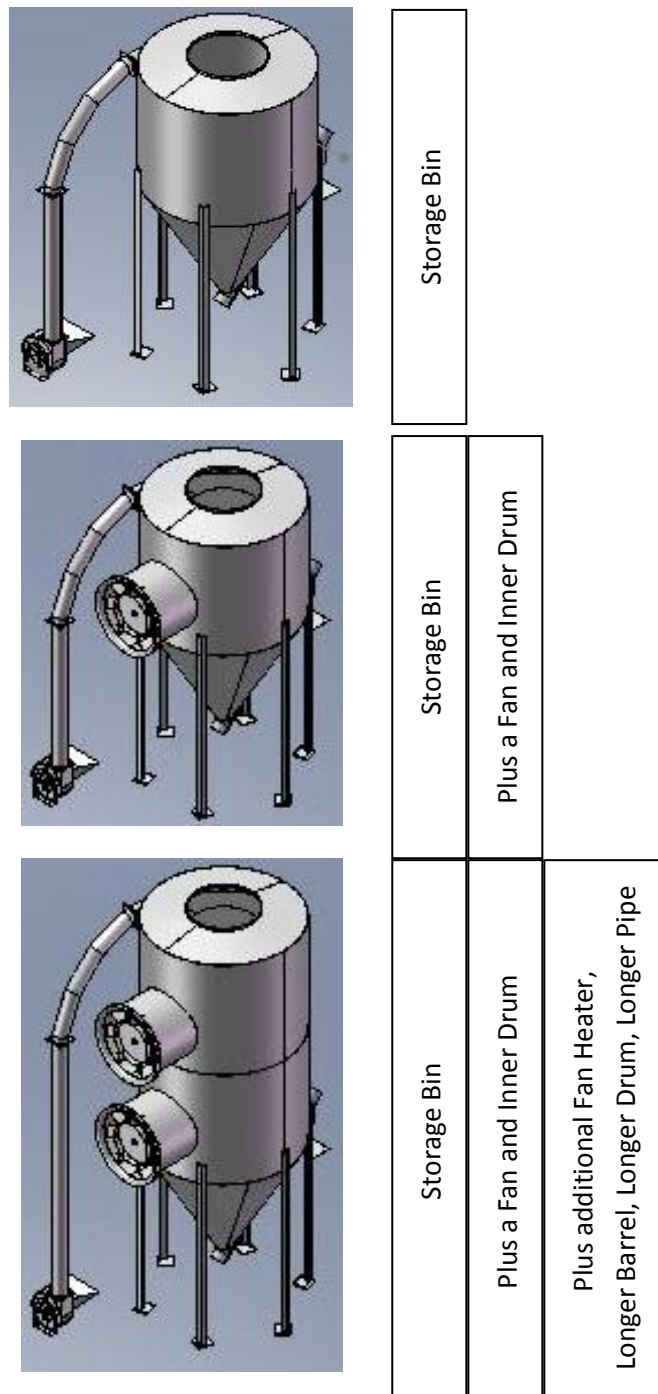

Figure 95: The addition of Sub-Assemblies or Modules to a Product Platform, to enable performance of different Overall Functions demonstrating the Quality Ladder (shown here up to Three Steps)

The issue of product size ranges becomes important as illustrated by the third step of Figure 95. The advantages of the product size ranges and modular products are that:

1. Once done, the design work is useful to a lot of applications;

2. Cost effectiveness and the attainment of higher quality may be achieved through the production of selected product sizes;
3. The design work ultimately becomes the selection of sub-assembly suppliers

These advantages are in line with the requirements of the Integrated Support Programme for Arable Agriculture Development (ISPAAD) and Young Farmers Fund (YFF).

6.3.2.1.1 Concept Selection

6.3.2.1.1.1 Introduction

The selection of sub-assemblies and concept variants is a key feature of conceptual design. The selection of the street illumination technology illustrates the concept selection process. This was done in conjunction with the energy section of RIPCO (B) in product design activities lead by an electrical and electronic engineer in February 2009.

The streetlight project results from the recommendation of the Energy Audit Project as per RIPCO (B) Project File Number: 360 (Project Design Office, 2009) of the Rural Industries Promotions Company (Botswana). A prototype has been developed, installed and is operational at the main entrance gate of the Rural Industries Innovation Centre (RIIC) in Kanye. RIIC is a subsidiary of RIPCO (B). The Energy Audit Project proposed the development of a safe and cost effective streetlight for use in infrastructure security especially during national power shedding. The streetlight should be preferably powered by renewable energy (to substitute the Botswana Power Corporation streetlight which uses fossil fuels via the National Electricity Power Grid).

The streetlight concept selection process is comprised of the following five steps in no particular order and with iterations: Formulation of Design Criteria, Description of Design Options, Evaluation of Design Options, Design Option Selection Error Analysis, and Attacking the Negatives (Figure 96). These steps were repeated in several sequences.

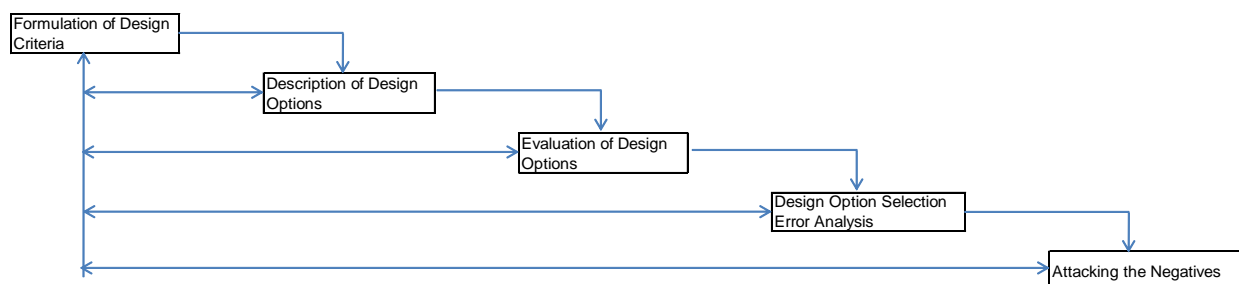

Figure 96: Concept Selection Process

This selection process addresses issues raised at the both the second and the third design reviews held on the 20th and 29th January 2009, respectively. The process

was meant to focus on clarifying and developing a deeper understanding of the streetlight concepts; to foster elucidation of the concepts among members of the design review panel in an effort to reach consensus at a fourth design review scheduled for 19th February 2009.

6.3.2.1.1.2 Step 1: Formulation of Design Criteria

The following three main criteria were used as scoped (by the sub-criteria). These criteria emanate directly from a selection of the engineering specification for the photovoltaic streetlight as per RIPCO (B) File Number: 362 (Project Design Office, 2009); these criteria clearly distinguish the differences between the streetlight concepts. The measureable scales for each criterion are as shown (in brackets).

- Customer Satisfaction
 - Market Acceptance in terms of operating hours and sustained operation during periods of adverse weather conditions (time = hours or days)
 - Life-Span in terms of the shortest component to fail (time = years)
- Technical Difficulty
 - Performance to provide the brightness (luminance = flux)
 - Power Consumption to discharge the electrical energy generating source (Power = kiloWatt)
- Cost
 - Selling Cost refers to the total cost of buying the components from vendors including installation costs (Cost = Botswana Pula).
 - Maintenance Cost are the costs to replace components as they reach their end of life excluding costs for repair and disposal (Cost = Botswana Pula)

(The 19 days average exchange rate for February 2009 is £1 = P 11.4905
[Source: <http://www.x-rates.comd/BWP/GBP/hist2009.html>])

6.3.2.1.1.3 Step 2: Description of Design Options

A choice is to be made between a photovoltaic streetlight, Botswana Power Corporation streetlight, hybrid powered streetlight and a light emitting diode streetlight; the hybrid powered streetlight concept has not been physically erected, hence the selection is rendered slightly risky – a light emitting diode streetlight has been visited near the Mmokolodi Nature Game Reserve in the South East District, Botswana . The selling costs for the streetlight concepts range from P 3,182.50 to P 9,828.77.

Concept 1. Photovoltaic Streetlight

The sunrays reach the 12 V / 80 W solar modules which convert the solar energy from the sunrays into electrical energy (Figure 97). A power cable conducts electric

current to the 10 A phocos charge controller which selectively allows it to pass, via another power cable, to the 12 VDC / 102 AH battery to store the electrical energy: if the battery is full, then it cuts off the electric current; when there is no sunlight, the charge controller switches to drawing electric current from the battery. The charge controller also has an in-built daylight ON/OFF switch and has a setting that prevents excessive discharge of the battery. A 12 VC / 11 W bulb is fitted via a lamp and connected via a power cable to the charge controller. All these electrical components are connected and secured on a pole

All electrical components would be bought from vendors. The pole, together with holding frames for the solar module and battery, would be manufactured at RIIC.

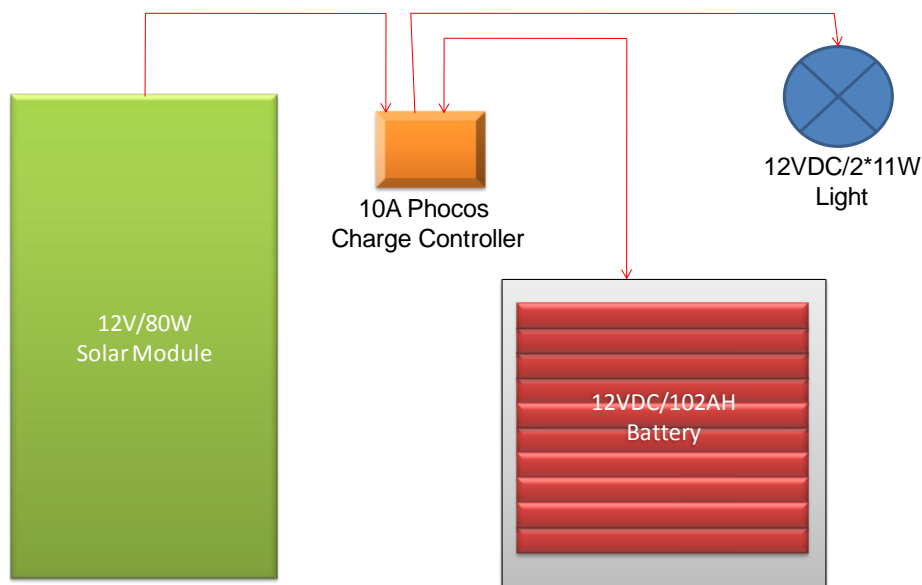

Figure 97: Block Diagram for Photovoltaic Streetlight

Concept 2. Botswana Power Corporation Streetlight

Electrical power is supplied through the Botswana Power Corporation grid system by means of a distribution box that has been fitted with circuit breaker for isolation during maintenance (Figure 98). A 230 ACV / 100 W bulb is connected through a daylight switch to the distribution box.

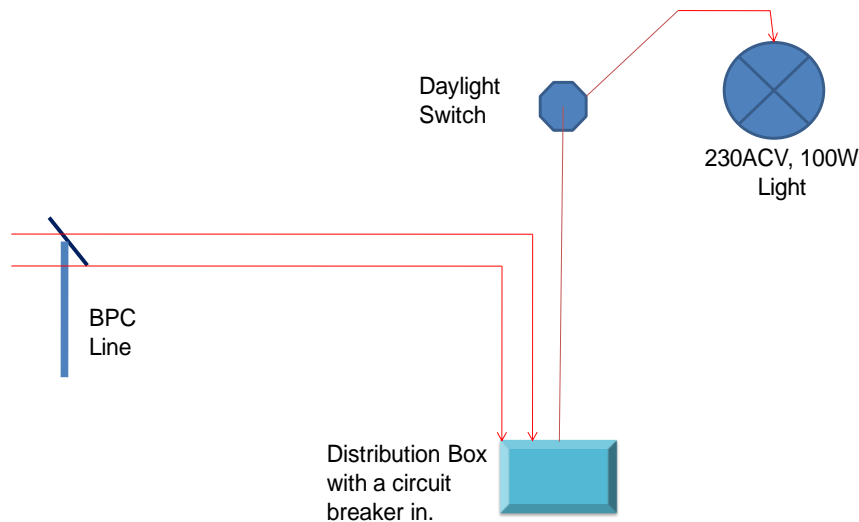

Figure 98: Block Diagram for Botswana Power Corporation Streetlight

Concept 3. Hybrid Streetlight

A hybrid streetlight system comprised of the superimposition of the Botswana Power Corporation streetlight system into the photovoltaic streetlight (Figure 99). This is accomplished through a battery charger. The 10 A phocos charge controller has an additional function of switching the charging of the 12 V / 102 AH battery when it discharges below the set depth (of discharge) to the mains if there is no sunlight.

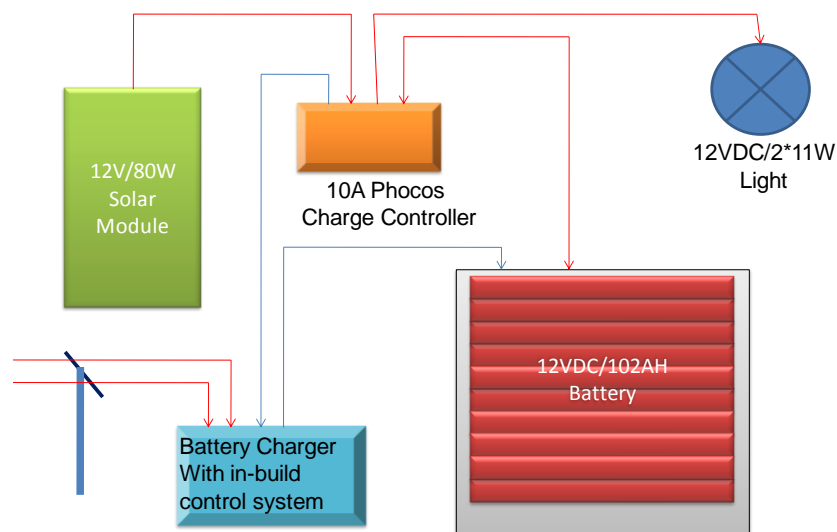

Figure 99: Block Diagram for Hybrid Powered Streetlight

Concept 4. Light Emitting Diode Streetlight

The light emitting diode streetlight consists of a the same arrangement as the photovoltaic streetlight except that the floodlight comes with an in-built daylight switch – this function is therefore not required from the charge controller (see Figure 100).

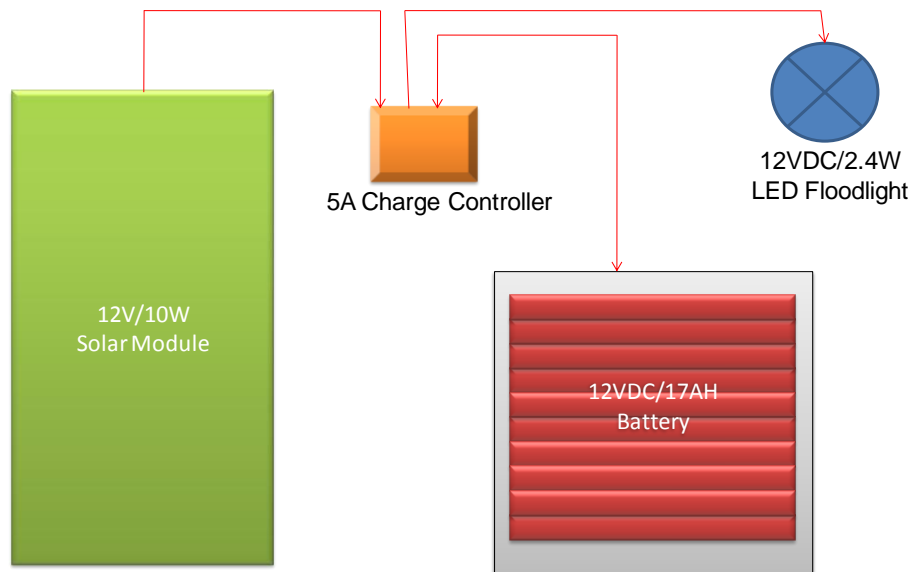

Figure 100: Block Diagram for Light Emitting Diode Streetlight

6.3.2.1.1.4 Step 3A: Evaluation of Design Options through Estimation

Current street lighting systems use the Botswana Power Corporation streetlight as a standard to provide the required luminance at night or during weather conditions that render poor (human) visibility. This is because this option minimizes a lot of required design and development effort. The other streetlight concepts are being developed as alternative options; and it is important to know their viability which is determined by the luminance of the light source and power consumption. These quantities should be estimated by examining the lighting load. During the day, the solar module converts solar energy into electrical energy which is then stored in a battery. During conditions of low human visibility, the bulb is switched on to convert electrical energy to light. These flows of energy could be easily estimated. An alternative approach is to establish the required luminance and work backwards to size the electrical components; this latter approach is plausible since there is finite variety of bulbs and solar modules available in the market.

1) Electrical-Light Energy Conversion

The photovoltaic streetlight option is being checked for operation at two power settings of 11 W and 22 W (to be consumed by similar bulbs with the different power requirements). The bulbs are expected to light for the about 12 hrs daily. Giving a luminance of approximately 4.3 flux, the 11 W lighting system would have a daily consumption of (Equation 27):

$$P = 11 \text{ W} \times 12 \text{ Operating Hours} = 132 \text{ W} - \text{hr}$$

Equation 27: Daily Power Consumption

On the other hand, the 22 W bulb would consume twice as much power for a luminance of 8 flux. It is required to have a minimum of 0.5 flux for a streetlight; hence the 22 W should be dropped from the set of concept variants.

2) Electrical Energy Storage

The sizing of the battery bank depends on the storage capacity required, the maximum discharge rate, the maximum charge rate, and the minimum temperature at which the battery would be used. The lead-acid battery used is a 12 V / 102 AH. In Botswana, cloud cover can last to about 4 days maximum, when there would be no input charging. Daily electrical current consumption would be (Equation 28):

$$I = \frac{132 \text{ W} - \text{hr}}{12 \text{ V}} = 11 \text{ AH}$$

Equation 28: Daily Electrical Current Consumption

The electrical energy storage required would be (Equation 29):

$$P_{\text{storage}} = 4 \text{ Cloud Cover Days} \times 11 \text{ AH} = 44 \text{ AH}$$

Equation 29: Stored Electrical Energy

The photovoltaic streetlight option considered has a charge controller to set the limited depth of discharge to 20% discharge of a full stored charge capacity of the system. This means that the required updated storage is (Equation 30):

$$\frac{44 \text{ AH}}{20\%} = 220 \text{ AH}$$

Equation 30: Discharge-Updated Stored Electrical Energy

Temperature has an effect on lead-acid batteries and at ambient temperature of about 15°C a load factor of 1.11 must be used to give a storage of (Equation 31):

$$220 \text{ AH} \times 1.11 = 244 \text{ AH}$$

Equation 31: Temperature-Updated Stored Electrical Energy

The number of batteries required, to be wired in parallel, is (Equation 32):

$$\frac{244 \text{ AH}}{102 \text{ AH}} = 2.4 \approx 3$$

Equation 32: Number of Batteries

The experimental set-up at the entrance to RIIC used a single battery which discharged at 10 A between 18:30 and midnight or about 2 A every hour when fitted with a 22 W bulb. The 11 W bulb could be expected to last until morning since it consumes half the power, for a constant voltage. It should also be noted that, similar calculations predict a single battery requirement for a depth of discharge of 50% with the 11 W bulb – this is acceptable practice: the battery could only be expected to drain to 50% during prolonged cloud cover which occurs seldom per year in Botswana.

3) Solar-Electrical Energy Conversion

The sizing of the required solar module depends on its daily charging ability which in turn depends on the available solar irradiance (average irradiance for Botswana is $523\text{W}/\text{m}^2$ charging for 6 hours per day (from insolation chart)). Recall that the daily electrical current consumption is 11 AH, but allowing for battery loss, a 20% factor should be included for a total consumption of (Equation 33):

$$11 \text{ AH} \times 1.2 = 13 \text{ AH}$$

Equation 33: Updated Daily Electrical Current Consumption

The average daily charging current would be (Equation 34):

$$\frac{13 \text{ AH}}{6 \text{ Charging Hours}} = 2.2 \text{ A}$$

Equation 34: Average Daily Charging Electrical Current

With a peak voltage of 17 V, a 60 W solar module would produce a current of: (Equation 35)

$$\frac{60 \text{ W} \times 0.523 \text{ W}/\text{m}^2}{17 \text{ V}} = 1.85 \text{ A}$$

Equation 35: Electrical Current Consumption from a 60 W Solar Module

The total solar modules required is (Equation 36):

$$\frac{2.2 \text{ A}}{1.85 \text{ A}} \times 60 \text{ W} = 1.2 \times 60 \text{ W} = 72 \text{ W} \approx 80 \text{ W}$$

Equation 36: Required Solar Module

The 60 W solar modules were used to power the “Ga Le Phirime” Rural Electrification Programme which used to be provided by RIPCO (B). For a standard 2½ roomed house with five 40 W bulbs, a television set and a radio, four 60 W solar modules were used with a storage bank of four 12 V / 102 AH batteries – there were some restrictions on the number of rooms lit and simultaneous use of appliances. It would be reasonable to assume about 180 W loading for the 408 AH battery bank.

6.3.2.1.1.5 Step 3B: Evaluation of Design Options through Decision Matrices

There are many effective ways of making concept selection through decision matrices. These matrices require different evaluation scales; hence, they give differing basis for selecting concepts.

Decision Marix 1. Pro/Con Matrix

The positive and negative evaluations for each of the alternative streetlight concepts were tabulated in Figure 101 and the evaluation scale shown in Equation 37.

$$\begin{Bmatrix} Con \\ Neither \\ Pro \end{Bmatrix} = \begin{Bmatrix} Disadvantage \\ No Effect \\ Advantage \end{Bmatrix}$$

Equation 37: Pro/Con Matrix Evaluation Scale

		Concepts			
					
		See Figure 97	See Figure 98	See Figure 99	
		Photovoltaic Streetlight	Botswana Power Corporation Streetlight	Hybrid Powered Streetlight	Light Emitting Diode Streetlight
Pro	ReNewable Energy		Cheapest Price of Components	ReNewable Energy	ReNewable Energy
	Low Power Requirements		Less Complicated	Power Source Back-Up	High Luminance
	Universal Energy Source				Low Power Requirements
	Less Danger of Shock				Universal Energy Source
Con	High Initial Investment		Fossil Fuels	High Initial Investment	Less Danger of Shock
	Succceptable to Weather		High Maintenance Costs	High Installaion Costs	Succceptable to Weather
			Succceptable to Power Shedding	High Number of Parts	
			High Installation Costs		

Figure 101: Pro/Con Matrix

The Botswana Power Corporation streetlight is the only one that does not use the universally available renewable energy; and its installation is least complicated and would cost about P 500.00. The hybrid powered streetlight has the rare advantage of dual power supply. The susceptibility to weather conditions of both the photovoltaic and the light emitting diode streetlights should be traded-off with the cheap costs of components for the Botswana Power Corporation streetlight and the frequency of power shedding.

Decision Marix 2. Convergence Matrix

The streetlight concepts are ordinal-ranked on each design criterion using a scoring scale of {-1, 0, 1}. The photovoltaic streetlight was selected as a datum and given a score of {0}. The other concept would be given a score of {-1} where it is comparatively inferior otherwise it would have a score of {1} (see Equation 38 and Figure 102).

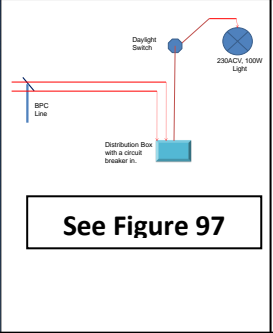
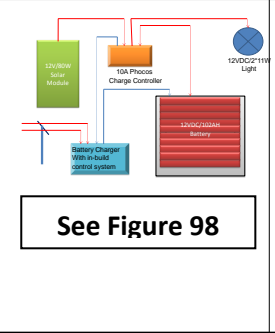
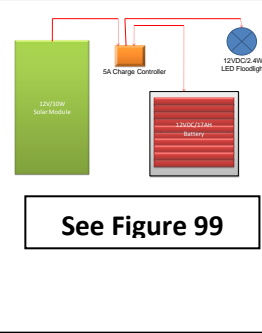
$$\begin{Bmatrix} -1 \\ 0 \\ +1 \end{Bmatrix} = \begin{Bmatrix} Worse \\ Same \\ Better \end{Bmatrix}$$

Equation 38: Convergence Matrix Evaluation Scale

At a selling cost of P 9, 828.77, the Hybrid Powered Streetlight has the highest annual maintenance expenses (Table 37). Light bulbs used on the photovoltaic streetlight consume 11 Watt of electrical power and have a lifespan of approximately two years while the Botswana Power Corporation streetlight consume 100 W and a

replacement could be expected annually; the life-span for the light emitting diode is more than four years.

	Component	Duration	Amount (P)	Annual Amount (P)	Total Annual Maintenance Cost (P)
PV Streetlight	Battery Replacement	3yrs	P990.00	P330.00	P484.00
	Bulbs	2yrs	P20.00	P10.00	
	Solar Module	25yrs	P3,600.00	P144.00	
BPC Light	Electricity Bill	1yrs	P616.83	P616.83	P687.83
	Bulbs	1yrs	P71.00	P71.00	
Hybrid	Battery Replacement	3yrs	P990.00	P330.00	P1,171.83
	Bulbs	2yrs	P20.00	P10.00	
	Solar Module	25yrs	P3,600.00	P144.00	
	Electricity Bill	1yrs	P616.83	P616.83	
LED	Bulbs	1yrs	P71.00	P71.00	P412.18
	Battery Replacement	3yrs	P381.80	P127.27	
	Bulbs	4yrs	P563.65	P140.91	
	Solar Module	25yrs	P3,600.00	P144.00	

Table 37: Annual Maintenance Costs

A summary ranking of all scores of {1} indicate that the Light Emitting Diode Streetlight is superior in a five criteria; and that for scores of {-1} show that the hybrid powered streetlight is inferior in three criteria. Compared to the Botswana Power Corporation streetlight, the photovoltaic streetlight is superior by one criterion. The market acceptance criteria do not distinguish between the two concepts, although they are critical.

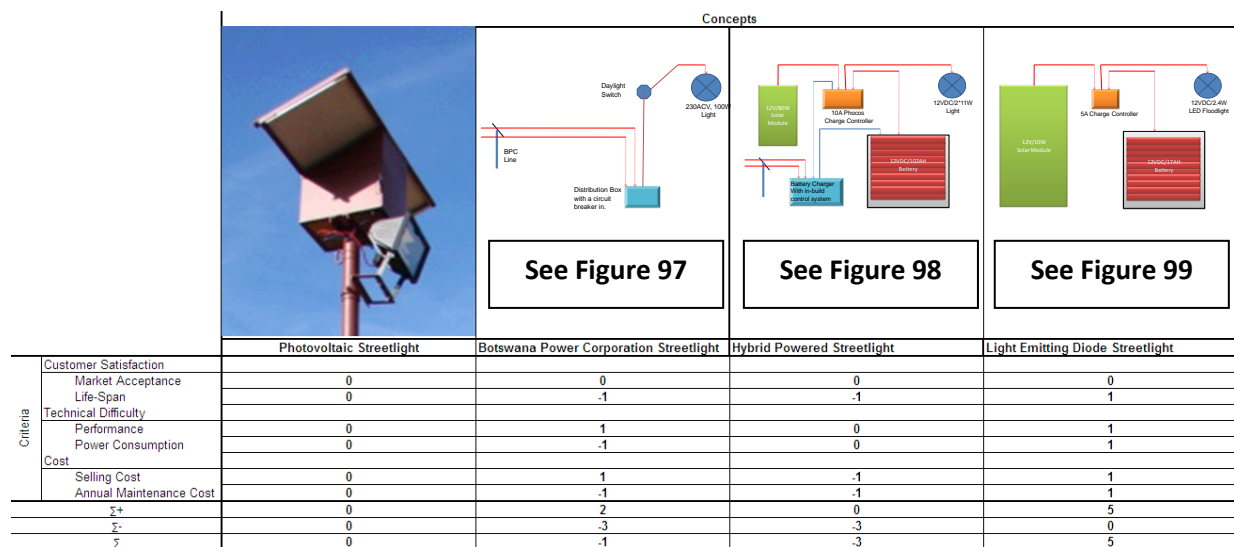

Figure 102: Convergence Matrix

Decision Marix 3. Weighted Sum Matrix

Since no customer needs have been compiled, a numerical analysis (Table 38) to determine the importance of the criteria indicates that market acceptance has the highest maximum impact – with a zero impact, the life-span has no relative importance (Figure 103). The criteria were checked against each other, and the dominant criterion given a full point. The maximum effect is the quotient of the criterion score and the solar maximum score (Equation 39).

$$\text{Maximum Effect} = \frac{\text{Criterion Score}}{\text{Maximum Score}}$$

Equation 39: Maximum Effect

Customer Satisfaction	A	-					
	B	A	-				
	C	A	C	-			
		D	A	D	C	-	
	E	A	E	C	D	-	
		F	A	F	F	F	-
Maximum Effect		5	0	3	2	1	3
		1	0	0.6	0.4	0.2	0.6

Table 38: Numerical Analysis

The photovoltaic streetlight remained the least datum as in the other convergence matrix. Interval scales were defined between the datum and the best performing concept in a criterion. All the other concepts were scored relative to the two datum. In order to normalize the scores across all the criteria, by multiplying the maximum impact by the difference between the highest and lowest scores in a criterion (Equation 40 shows an example for the selling cost):

$$\begin{aligned} & \text{Normalised Maximum Impact} \\ &= \frac{\text{Selling Cost of a Concept} - \text{Selling Cost of Photovoltaic Streetlight}}{(\text{Selling Cost of BPC Streetlight} - \text{Selling Cost of Photovoltaic Streetlight})} \\ & \times \frac{\text{Maximum Effect}}{\text{Selling Cost of Hybrid Powered Streetlight} - \text{Selling Cost of Photovoltaic Streetlight}} \end{aligned}$$

Equation 40: Normalized Maximum Effect of Selling Cost

The selected concept is the light emitting diode streetlight as it is the only option with a positive, and hence highest, total normalized maximum effect (Figure 103).

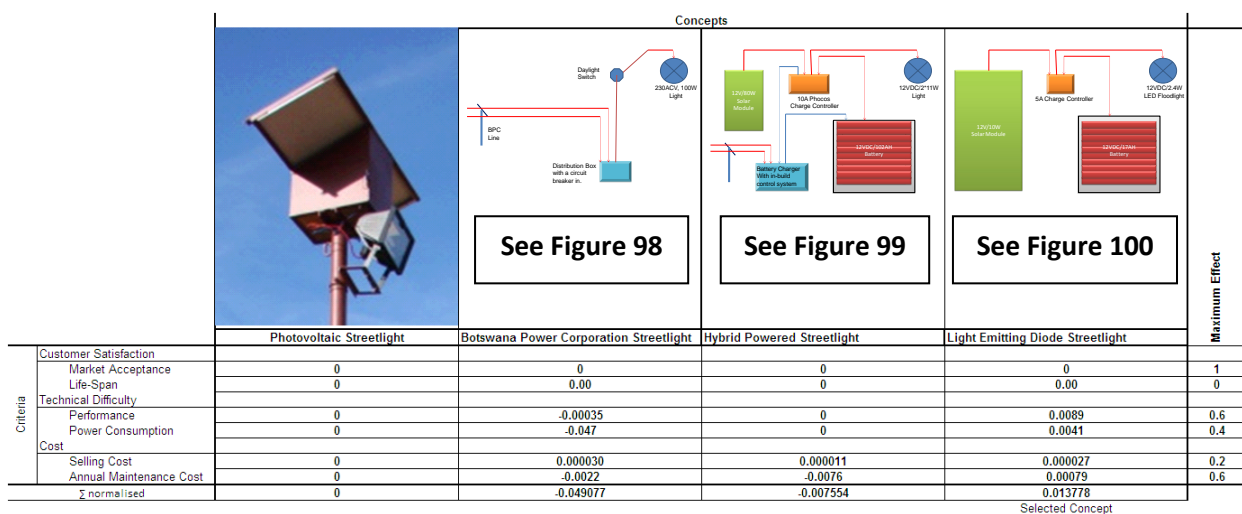

Figure 103: Weighted Sum Matrix

6.3.2.1.1.6 Step 4: Design Option Selection Error Analysis

This step entails an evaluation of uncertainties in the measurement and formulae used for estimations and in the decision matrices. This step was not done.

6.3.2.1.1.7 Step5: Attacking the Negatives

The photovoltaic streetlight is inferior on the basis of the selling cost and performance criteria – it does give a luminance of 4.3 flux (> 0.5 flux required by standards). An economic analysis was conducted based of an inflation of 8% (average inflation for Botswana in the period 1990 – 2000) and the prevailing bank borrowing rate 24% over a 25 year period. The initial investment was computed as the difference between the selling costs of the concepts; the annual returns (cash flows) were calculated as the difference between their maintenance costs.

At -P 1, 952.38, the Net Present Value point to the rejection of the photovoltaic streetlight. This is due to both the price and frequency of replacing the battery and an exceptionally high initial investment.

The Internal Rate of Return indicates that the photovoltaic streetlight is economically viable on donated money after 10 years lifespan; on a negotiated bank borrowing rate of 10%, the photovoltaic streetlight would be economically viable after 25 year.

6.3.2.1.2 Detail Design and Concept Embodiment

Like the conceptual design and concept selection, detail design is considered as part of a single technique in this research. Detail design may be considered as that part of conceptual design which continues the process started by concept selection to converge towards a best concept variant (Figure 91). In essence, detail design transforms and refines the configuration sketches and product architectures of concept variants into realisable physical products that satisfy the customer with minimum probability of failure. However, the conceptual design, concept selection and detail design are divergent in that they all try to expand some aspects of the concept variants and there is a high level of iteration between their executions. This sub-section deals with part of the detail design for the bulk storage bin as an example.

The implementation of detail design is characterised by the extensive use of literature such as catalogues and textbooks including quotations from suppliers. In the detail design of the bulk storage bin, the textbooks for strength of materials, pneumatic conveying and fan handbook were consulted. Sometime the suppliers provide ready made standard sub-assemblies, catalogues provide information on the raw material such as steel sections and textbooks enable the design team to apply their skills of mathematics and applied science. Because of these characteristics of detail design, it is sometimes used synonymously with concept embodiment i.e. a concept variant embodies product details. In this research, concept embodiment is

more general perhaps synonymous with the entire Design Principle or Rules 8, 9 and 10. Both detail design and concept embodiments require inventive, adaptive and variant product design strategies and can show if the design team is competent at modelling and testing. The execution of both detail design and embodiment design require the design team to address issues related to manufacturing, cost and geometry (product architecture).

The material of choice for RIPCO (B) based on the employee experience and the equipment in the manufacturing workshop is steel. There were three options for the type of steel to use: galvanised steel, hot rolled mild steel and cold rolled mild steel. The detail design for the sub-systems was performed based on these materials. In this thesis, a focus is given for the storage bin without including the impeller blower and the conveying pipe. All these calculations were performed using MS Excel spreadsheet.

6.3.2.1.2.1 Barrel and Hopper of the Bulk Storage Bin

From the catalogue of a local steel supplier, the availability of a rectangular shaped sheet of steel measuring 2450 X 1225 mm was selected. The objective was to use two lengths of the steel sheet for the diameter of the bin barrel and a single width of the sheet for the length of the smallest storage bin by size. This gives a bin barrel with a diameter of 1560 mm and a total volume of 2.3 m³.

There are three grain for which the bulk storage bin was to be designed: sorghum, maize and *morama*. The angle of repose for these grains is (Table 39):

Grain	Symbol	Angle of Repose
Sorghum	$\Theta_{\text{sorghum-repose-angle}}$	28.5 deg.
Maize	$\Theta_{\text{maize-repose-angle}}$	26.0 deg.
<i>Morama</i>	$\Theta_{\text{morama-repose-angle}}$	9.8 deg.

Table 39: Angle of Repose of Grain

The angle of repose for the grain is used to determine the minimum slope of the bottom part of the bulk storage bin. From catalogues of grain storage bins available over the internet, it was observed that two angle were consistently used for the storage bins: 45⁰ and 60⁰. The 60⁰ angle was selected giving a factor of safety of about 2 based on sorghum.

The bin hopper must have the same size of diameter; to simplify the cutting of the sheet for the bin hopper so as to limit wastage, mathematical equations for similar triangle were used to determine its height of 1531 mm and total volume of 0.9 m³. Therefore the total volume of the storage bin is 3.2 m³ and the total height without the frame is 2.58 m.

The bulk density of the grain is also important so as to size the volume of the bulk storage bin (Table 40):

Grain	Symbol	Bulk Density
Sorghum	$\rho_{\text{sorghum-bulk-density}}$	721 kg/cu. M
Maize	$\rho_{\text{maize-bulk-density}}$	760 kg/cu. m
Morama	$\rho_{\text{morama-bulk-density}}$	660 kg/cu. M

Table 40: Bulk Density of Grain

Based on the bulk density of the grains, it may be calculated that the bulk storage bin would manage to hold (Table 41).

Grain	Sysmbol	Total Mass
Sorghum	$m_{\text{sorghum-seed-weight}}$	2308 kg
Maize	$m_{\text{maize-seed-weight}}$	2433 kg
Morama	$m_{\text{morama-seed-weight}}$	2113 kg

Table 41: Maximum Mass of Grain that can be Stored

It will be seen that the maximum mass of maize grain is the highest that could be stored (Table 41); hence, it was used to calculate the circumferential stress on the storage bin. The galvanised sheet was rejected because the calculated factor of safety based on based on all the grains was less than one (Table 42); this means the storage bin would collapse. The longitudinal stress is not important as a selection criterion because it is half the circumferential stress.

Mechanical Properties of SAE/AISI 1035 Steel		Galvernised		
Condition		Hot Rolled	Hot Rolled	Cold Rolled
Tensile Yield Strength		276 MPa	276 MPa	496 MPa
Ultimate Tensile Strength		462 MPa	462 MPa	552 MPa
Theoretical Circumferential Stresses				
Theoretical Circumferential Stresses on the Sorghum Bin	$\sigma_{\text{sorghum-bin-circumferential-stress}}$	324.4 MPa	162.2 MPa	324.4 MPa
Theoretical Circumferential Stresses on the Maize Bin	$\sigma_{\text{maize-bin-circumferential-stress}}$	342.0 MPa	171.0 MPa	342.0 MPa
Theoretical Circumferential Stresses on the Maize Bin	$\sigma_{\text{morama-bin-circumferential-stress}}$	297.0 MPa	148.5 MPa	297.0 MPa
Calculated Safety Factor				
Calculated Safety Factor for the Sorghum Bin	$\lambda_{\text{sorghum-safety-factor}}$	0.9	1.7	1.5
Calculated Safety Factor for the Maize Bin	$\lambda_{\text{maize-safety-factor}}$	0.8	1.6	1.5
Calculated Safety Factor for the Morama Bin	$\lambda_{\text{morama-safety-factor}}$	0.9	1.9	1.7
Theoretical Longitudinal Stresses				
Theoretical Longitudinal Stresses on the Sorghum Bin	$\sigma_{\text{sorghum-bin-longitudinal-stress}}$		81.1 MPa	162.2 MPa
Theoretical Longitudinal Stresses on the Maize Bin	$\sigma_{\text{maize-bin-longitudinal-stress}}$	Reject this Steel Section	85.5 MPa	171.0 MPa
Theoretical Longitudinal Stresses on the Morama Bin	$\sigma_{\text{morama-bin-longitudinal-stress}}$		74.2 MPa	148.5 MPa

Table 42: Circumferential and Longitudinal Stress of the Grain on the Bulk Storage Bin

6.3.2.1.2.2 Frame of the Bulk Storage Bin

The virtual method (or energy method) as explained by Case et. al. (1983) was used to select the steel section for fabricating the frame that supports the storage bin (Table 43).

Frame Design (Energy Methods - Virtual Work)		Hot Rolled	Cold Rolled
Safety Factor	$\lambda_{\text{frame-safety-factor}}$	3	3
Shape Factor (i.e. $M_{\text{plastic-moment-of-resistance}} + M_{\text{elastic-moment-of-resistance}}$)	S	1.15	1.15
Height of Frame (= Height of Hopper (Cone))	H_{frame}	1351 mm	1351 mm
Width of Frame (=Diameter of the Barrel)	W_{frame}	1560 mm	1560 mm
Forces			
Vertical Force in the Middle (=Weight of Grain)			
Weight of Sorghum	$m_{\text{sorghum-seed-weight}}$	2308 kg	2308 kg
Weight of Maize	$m_{\text{maize-seed-weight}}$	2433 kg	2433 kg
Weight of Morama	$m_{\text{morama-seed-weight}}$	2113 kg	2113 kg
Horizontal Forces			
Wind Forces	$W_{\text{wind-horizontal-forces}}$	0 kg	0 kg
Failure Modes			
Beam Mechanism			
Failure of Sorghum Bin by Beam Mechanism	$FM_{\text{sorghum-bin-beam-mechanism-failure}}$	2.9 kNm	2.9 kNm
Failure of Maize Bin by Beam Mechanism	$FM_{\text{maize-bin-beam-mechanism-failure}}$	3.1 kNm	3.1 kNm
Failure of Morama Bin by Beam Mechanism	$FM_{\text{morama-bin-beam-mechanism-failure}}$	2.7 kNm	2.7 kNm
Sway Mechanism			
Failure of Sorghum Bin by Sway Mechanism	$FM_{\text{sorghum-bin-sway-mechanism-failure}}$	0.0 kNm	0.0 kNm
Failure of Maize Bin by Sway Mechanism	$FM_{\text{maize-bin-sway-mechanism-failure}}$	0.0 kNm	0.0 kNm
Failure of Morama Bin by Sway Mechanism	$FM_{\text{morama-bin-sway-mechanism-failure}}$	0.0 kNm	0.0 kNm
Combined Beam and Sway Mechanism			
Failure of Sorghum Bin by Combined Beam and Sway Mechanism	$FM_{\text{sorghum-bin-combined-beam-and-sway-mechanism-failure}}$	2.2 kNm	2.2 kNm
Failure of Maize Bin by Combined Beam and Sway Mechanism	$FM_{\text{maize-bin-combined-beam-and-sway-mechanism-failure}}$	2.3 kNm	2.3 kNm
Failure of Morama Bin by Combined Beam and Sway Mechanism	$FM_{\text{morama-bin-combined-beam-and-sway-mechanism-failure}}$	2.0 kNm	2.0 kNm
Maximum Plastic Moment of Resistance	$FMM_{\text{plastic-moment-of-resistance}}$	3.1 kNm	3.1 kNm
Design Plastic Moment of Resistance	$M_{\text{plastic-moment-of-resistance}}$	9.3 kNm	9.3 kNm
Design Elastic Moment of Resistance	$M_{\text{elastic-moment-of-resistance}}$	8.1 kNm	8.1 kNm
Section Modulus	$Z_{\text{section-modulus}}$	29.32 cu. cm	16.31 cu. cm
Selected Hot Rolled Steel Section		100 x 100 x 12 Angle Iron	80 x 80 x 12 Angle Iron
		100 x 50 Channel Iron	65 x 65 Channel Iron

Table 43: Steel Section for supporting the Bulk Storage Bin

A quotation for mild steel was sought from a local supplier (Figure 104).

Material Supplier	Tel							
Address	Fax							
	VAT Reg. C06372601112							
	Sales - Quote							
	Date 04 March 2011							
	Quote No. SQ84424							
	12% VAT							
	Sterling/Pula Exchange Rate							
	£ 1.00 P 10.66 08 March 2011							
	Price (Pula) Price (£)							
	(Excl VAT) (Excl)							
Supplier No.	Description	Thickness	Length	Width	Unit Size	Quantity	Price (Pula)	Price (£)
SHE010	Hot Rolled Sheet	4 mm	2450 mm	1225 mm	3.00 sq. m	1	P 818.90	£ 76.85
SHE007	Hot Rolled Sheet	3 mm	2450 mm	1225 mm	3.00 sq. m	1	P 627.80	£ 58.92
RO052	Round Tube 152.4 m	4 mm	6000 mm		6.00 m	1	P 1,140.05	£ 106.99
EQA058	Equal Angle 100 X 10	10 mm	6000 mm		6.00 m	1	P 851.35	£ 79.90
							P 3,438.10	£ 322.66

Figure 104: Quotation for Steel

From this quotation the 3 mm rectangular sheet is cheaper; however, the 4 mm hot rolled rectangular sheet was selected because it was available from RIIC material stores. The procurement procedure at RIIC is very lengthy.

The output from detail design and concept embodiment is technical drawings (Figure 105).

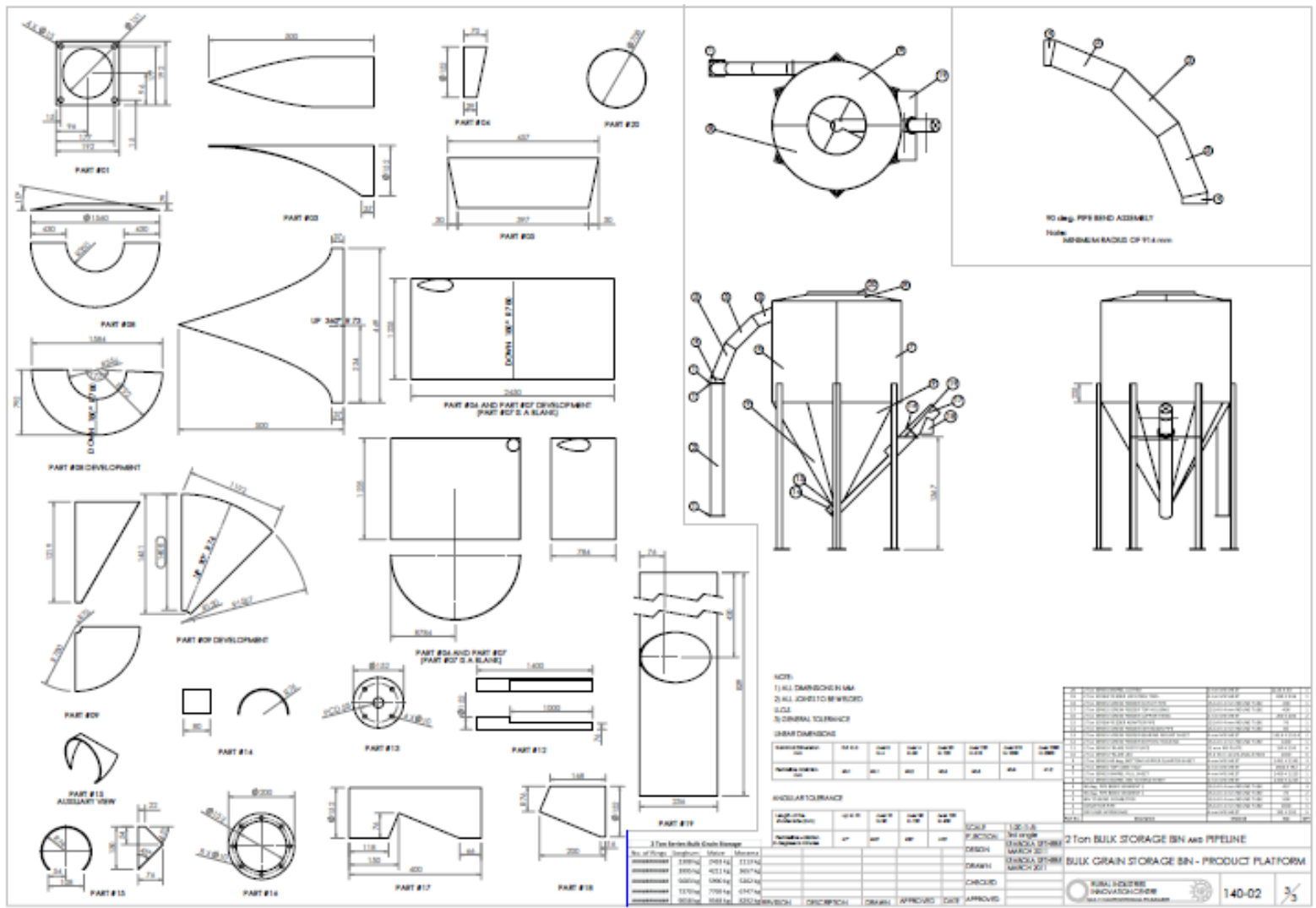

Figure 105: Technical Drawing of the Barrel, Hopper and Frame of Bulk Storage Bin

6.3.2.1.3 Physical Prototype Model, Failure Mode Effect Analysis (FMEA) and Manufacturing Planning

According to Otto and Wood (2001), there are six general classes of prototypes, listed here in the order of progression of complete understanding of the underlying physics of the product: Proof-of-Concept Prototypes, Industrial Design Prototypes, Design of Experiments Experimental Prototypes, Alpha Prototypes, Beta Prototypes and Pre-Production Prototypes. These classes of prototypes have associated levels of validation tests.

1. Proof-of-Concept Prototypes: These are used to answer specific questions of feasibility i.e. a confirmation of whether the imagined physics of the concept on paper actually happen and the identification of any unforeseen physics. They are usually constructed from simple and readily available materials after concept generation and typically during concept selection;
2. Industrial Design Prototypes: These demonstrate the look and feel of the product. They are usually constructed from foam and plastics materials or have a foam core (i.e. with no working internal components) and aim to demonstrate many options quickly;
3. Design of Experiments Experimental Prototypes: These are physical models where empirical data is sought to parameterize, layout or shape aspects of a product. They are fabricated from similar materials and geometry as the actual product but with the prototype being just similar to replicate the real product's physics but made as simple, quick and cheaply as possible;
4. Alpha Prototypes: These address the concern for overall layout of a product and are fabricated using the actual materials and geometry as will be used in the actual product with exact original equipment components. The Alpha Prototype is the first to be constructed with all sub-assemblies that are individually proven for Design of Experiments Experimental Prototyping;
5. Beta Prototypes are the first full scale functional prototypes of a product, constructed from the actual materials and geometry as the final product although they may not be fabricated with the same production process as the final product. Beta Prototypes are validated with test plans and analysed with failure modes and effects analysis (FMEA); and
6. Preproduction Prototypes: These are used to perform final part production and assembly assessment as the actual production tooling.

The manufacture of the physical prototypes for the products identified by the proliferation tree (Figure 84) should follow the sequence of the classes of prototypes. Table 44 shows the bill of material which accompanies the issuing of technical drawings. It should be noted that the 2.2 kW electric motor suitable for the impeller blower costs P 3 558.11 which is almost 50% of the material costs for the barrel and hopper of the bulk storage bin.

					Total Material Cost	P	6,474.66
20	2 Ton SERIES BARREL LID RIM	4 mm MS SHEET	2223 X 30	1	P	18.20	
19	2 Ton SCREW FEEDER LOCATING TOOL	4 mm MS SHEET	839 X 236	1	P	54.03	
18	2 Ton SERIES SCREW FEEDER OUTLET PIPE	152.4 X 4 mm ROUND TUBE	200	1	P	38.00	
17	2 Ton SERIES SCREW FEEDER TOP HOUSING	152.4 X 4 mm ROUND TUBE	400	1	P	76.00	
16	2 Ton SERIES SCREW FEEDER SUPPORT RING	4 mm MS SHEET	200 X 200	2	P	21.83	
15	2 Ton SCREW FEEDER ADAPTER PIPE	152.4 X 4 mm ROUND TUBE	76	1	P	14.44	
14	2 Ton SERIES SCREW FEEDER EXTENSION PIPE	152.4 X 4 mm ROUND TUBE	80	1	P	15.20	
13	2 Ton SERIES SCREW FEEDER BEARING MOUNT SHEET	4 mm MS SHEET	152.4 X 152.4	2	P	12.67	
12	2 Ton SERIES SCREW FEEDER BOTTOM HOUSING	152.4 X 4 mm ROUND TUBE	1400	1	P	10.06	
11	2 Ton SERIES FRAME FOOT PLATE	12 mm MS PLATE	150 X 150	6	P	36.84	
10	2 Ton SERIES FRAME LEG	65 X 65 X 12 MS ANGLE IRON	2000	6	P	1,702.80	
9	2 Ton SERIES 60 deg. BOTTOM HOPPER QUARTER SHEET	4 mm MS SHEET	1451 X 1192	3	P	1,415.77	
8	2 Ton SERIES TOP CONE HALF	4 mm MS SHEET	1584 X 792	2	P	684.60	
7	2 Ton SERIES BARREL FULL SHEET	4 mm MS SHEET	2450 X 1225	1	P	818.90	
6	2 Ton SERIES BARREL BIN TO BEND SHEET	4 mm MS SHEET	2450 X 1225	1	P	818.90	
5	90 deg. PIPE BEND SEGMENT 2	152.4 X 4 mm ROUND TUBE	457	3	P	260.50	
4	90 deg. PIPE BEND SEGMENT 1	152.4 X 4 mm ROUND TUBE	70	2	P	26.60	
3	BIN TO BEND CONNECTOR	152.4 X 4 mm ROUND TUBE	500	1	P	95.01	
2	CONVEYOR PIPE	152.4 X 4 mm ROUND TUBE	1600	1	P	304.02	
1	DIFFUSER APPENDAGE	4 mm MS SHEET	192 X 192	5	P	50.29	
Part No.	Description	Material	Size	QTY.	Cost of Material		

Table 44: Bill of Material for the Bin and Barrel of the Bulk Storage Bin (Source: Adapted from the RIPCO (B) Quality Office, 2008)

The production process plan is also developed to identify the manufacturing equipment and an estimate of the fabrication and machining times for each component and the assembly (Table 45).

PRODUCTION PROCESS PLAN

Part Name	Diffuser Appendage	Drawing Number	140 - 02	Material	4 mm MS Sheet	
Part Number	1	Quantity	1	Blank Size (mm)	192 X 192	
Operation No.	Machine / Equipment	Technological Process	Est. T _{mc} (min)	Est. T _{fb} (min)	Act. T _{mc} (min)	Act. T _{fb} (min)
1	Plasma Cutter	Cut the Required Profile	0	0	0	2
Total			0	0	0	2

Table 45: Production Process Plan to manufacture the Diffuser Appendage (Source: Adapted from the RIPCO (B) Quality Office, 2008)

Failure Mode and Effect Analysis (FMEA) is an analytical technique used to identify, characterize and do away with potential failures of a physical product when in se by the customer. FMEA links directly with detail design and concept embodiment which provide the variables defining a product at the generality levels of whole system, sub-systems and components. FMEA is also more useful when partnered with Beta prototypes.

FMEA analyses:

- 1) Failure Modes: What could fail at each level of generality of a product?
- 2) Failure Effects: To what extent might failure occur or what are the dangerous outcomes when failure occurs? and
- 3) Failure Criticality: What step could be implemented in case of failure or what is the relative importance of the failure states.

Table 46 shows a template of the FMEA chart developed for the sub-system level of the bulk storage bin. The bulk storage bin has three sub-assemblies issued on a set of three technical drawing following OP 7.3 Design and Development procedure (RIPCO (B) Quality Office, 2008):

1. The general assembly is a technical drawing of all three sub-assemblies joined together as in the final product;
2. The sub-assembly drawings for the impeller blower with its components; and
3. A sub-assembly drawing of the joined conveying pipe, the barrel and the hopper together with their components.

Product Name		Product Design Team						Page No. 1 of 1		
Names of the Sub Assemblies								Number 140 - 02 & 03 FMEA		
Part Number	Function	Potential Failure Mode	Potential Effects of Failure	Severity (S)	Potential Causes of Failure	Occurrence (O)	Current Tests	Detection	Recommended	Risk Priority
								(D)	Actions	Number (RPN)
RPN = S X O X D										
1	DIFFUSER APPENDAGE									
2	CONVEYOR PIPE									
3	BIN TO BEND CONNECTOR									
4	90 deg. PIPE BEND SEGMENT 1									
5	90 deg. PIPE BEND SEGMENT 2									
6	2 Ton SERIES BARREL BIN TO BEND SHEET									
7	2 Ton SERIES BARREL FULL SHEET									
8	2 Ton SERIES TOP CONE HALF									
9	2 Ton SERIES 60 deg. BOTTOM HOPPER QUARTER SHEET									
10	2 Ton SERIES FRAME LEG									
11	2 Ton SERIES FRAME FOOT PLATE									
12	2 Ton SERIES SCREW FEEDER BOTTOM HOUSING									
13	2 Ton SERIES SCREW FEEDER BEARING MOUNT SHEET									
14	2 Ton SERIES SCREW FEEDER EXTENSION PIPE									
15	2 Ton SCREW FEEDER ADAPTER PIPE									
16	2 Ton SERIES SCREW FEEDER SUPPORT RING									
17	2 Ton SERIES SCREW FEEDER TOP HOUSING									
18	2 Ton SERIES SCREW FEEDER OUTLET PIPE									
19	2 Ton SCREW FEEDER LOCATING TOOL									
20	2 Ton SERIES BARREL LID RIM									

Table 46: FMEA Chart template for the Barrel and Bin of the Bulk Storage Bin

To prepare for the pre-production prototype, referred to as a ‘sample’ in RIPCO (B), a manufacturing plan must be developed. In this research, a manufacturing plan was developed by combining the bill of material with the breakdown of the product into total system, sub-system and component level (Table 44 and Figure 90), production process (Table 45) actual times (for both fabrication and machining work), inventory records and the materials procurement plan (MRP). Such a combination was developed in view of the supply chain envisaged for which the YFF would supply physical products to the ISPAAD. MRP would identify the timely release of new production orders to the YFF, adjustment of order quantities and speed up late orders. The production process plan is transformed into a master production schedule (MPS) which shows the quantity of sub-assemblies and components to be produced by the YFF (Table 47).

	Month 1				Month 2			
	Week 1	Week 2	Week 3	Week 4	Week 5	Week 6	Week 7	Week 8
Barrel and Hopper								
Conveying Pipe								
Impeller Blower								
Aggregate Production Plan for the Bulk Storage Bin	0				0			

Table 47: Master Production Schedule Template

The MPS then feeds the Inventory record for each of the sub-assemblies (Table 48).

Description:	Barrel and Hopper				Production Lot Size: 20			
					Lead Time: 1 Week			
					Safety Stock: 10 units			
	Month 1				Month 2			
	Week 1	Week 2	Week 3	Week 4	Week 5	Week 6	Week 7	Week 8
Gross Requirements								
Scheduled Receipts								
Projected on Hand Inventory								
Planned Receipts								
Planned Order Releases								

Key:

Gross Requirements: Total Demand for the Barrel and Hopper

Scheduled Receipts: Orders that have been placed to the YFF by the ISPAAD but which have not been completed i.e. backlog

Projected on Hand Inventory: The beginning inventory in the storage warehouse of the YFF

Planned Receipts: New orders not yet released by the manufacturing workshop to the storage warehouse of the YFF

Planned Order Releases: The time when an order for a specified amount of Barrel and Hopper is issued

Table 48: Inventory Record Template for the Barrel and Hopper

6.3.2.2 Design Rule 9

As part of this research, five study trips were made to interact with the Rural Industries Promotions Company (Botswana) [RIPCO (B)]. The second study was in period January – June 2009 and was the first where the product design guidelines (PDG) proposed in this research (Chapter 5) were put to test. At the time, the PDG were only based on literature.

RIPCO (B) is one of the major institutions in Botswana that design products some of which have ended up being exported to other least economically developed countries (LDC). Among other jobs, RIPCO (B) provides product design services for products destined for one-off production to which they commonly refer to as customer inquiry. Results oriented prototyping work is an important characteristic of their product design method. As defined in the product design guidelines proposed by this research, prototype manufacture and verification trials show a change from function to form. Verification trials may lead to modifications to the prototypes – which is a demonstration of the often inevitable feedback of the product design process.

In this sub-section the tests on the maize dryer prototypes are described as well as some important details about the functions and main physical mechanisms. The operational factors which were used to formulate the analytical models and propose

modifications to the physical prototype are also described. In accordance with the RIPCO (B) Quality Management Documentation, the test so performed should inform the production strategy to produce a one-off product as opposed to batch production and mass production.

6.3.2.2.1 The Maize Dryer Physical Prototype

The maize dryer physical prototype is a machine intended to reduce moisture content of maize kernels. It is to be used as a new critical product in, and arose from inquiries made by, the cereal milling industry of Botswana. The processing of maize in this regard is three fold:

1. The maize, which would have been harvested and threshed, is soaked in water over a period which is normally between dusk in the evening and dawn in the morning – this signals the requirement to design a grain soaking product although this was not part of the customer inquiry;
2. The maize is then removed from the grain soaking product and processed in the grain dryer. Currently the maize that had been soaked is laid out in an open area and placed in a mat to be dried by the sun and wind;
3. The dried maize is then processed to make maize flour. RIPCO (B) has the dehuller and hammermill products that are commonly used to produce sorghum flour and this may open an opportunity to examine a re-design strategy to attain reasonable capacity to produce maize flour; however, this was exploited as yet.

The maize dryer, which had been manufactured by the end of 2008, consists of four functional sub-assemblies, which are (Figure 106 and Figure 107):

- The Electrical Fan Heater: This was an original equipment manufacture (OEM) component comprised of a small plastic propeller fan and electrical heating elements casing enclosed in a rectangular casing with two uncovered ends. One uncovered end allows the fan to suck air at atmospheric pressure and temperature into the rectangular enclosing box. The electric heating elements, which were six in number, were fixed within the rectangular enclosure and in front of the fan. The elements had two on-off press buttons and a two dial button to allow control for a range of heat settings; one set of on-off button and dial button powered three elements for a lower heat setting range and the other set of buttons allowed for powering all six elements for high heat setting range. The fan blows the air into the rectangular casing through the heating elements casing. It is provided with a safety guard and is painted red to indicate danger to the operator;
- The Rotary Drum: This is comprised of two nested drums and a stationary frame.
 - The inner drum could rotate within the outer drum and was made from perforated sheet with both ends capped. An access door was

provided on the inner drum to allow the intake and ejection of maize kernels.

- The outer drum was made from galvanised mild steel sheet and was comprised of four components: two fixed hemispherical components at the ends of two half cylindrical components. The top cylindrical component had an air vent to allow air to flow out. The outer drum had an opening at the base to allow for emptying of the dried maize kernels by gravity; and
- A stationary frame which was made mild angle irons supported by a stationary frame to the ground.
- The Outlet Tray: The tray communicated with the bottom cylindrical component of the outer drum to act as an outlet; and
- The Electrical Motor and Power Transmission: This was the main prime mover which rotated the inner drum through a belt and pulley power transmission system.

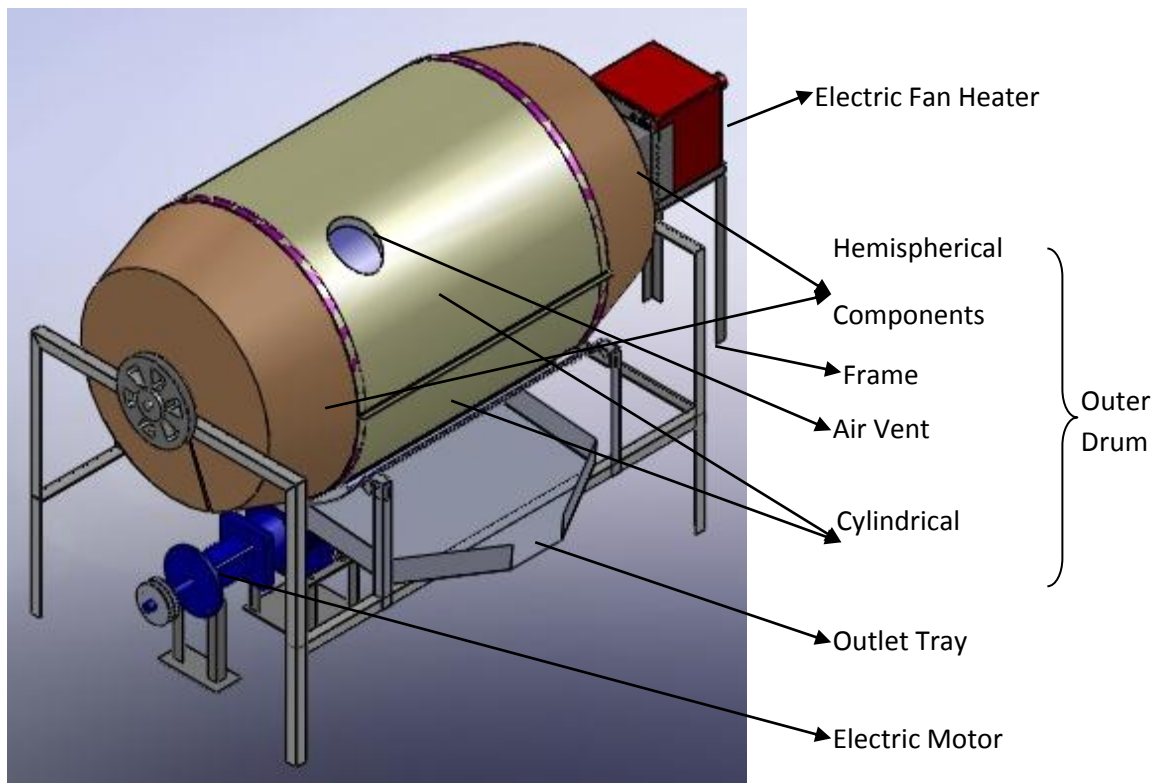

Figure 106: Isometric View of the Maize Dryer Beta Prototype (Source: RIPCO (B) Product Design Office)

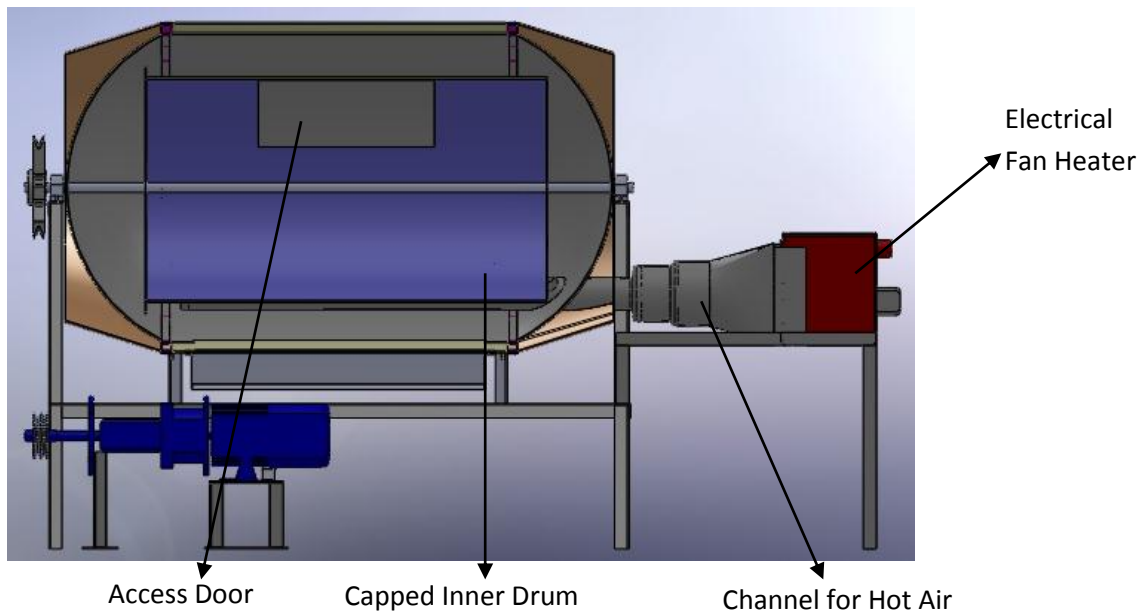

Figure 107: Section View of the Maize Dryer Beta Prototype (Source: RIPCO (B) Product Design Office)

The maize dryer prototype described above was classified as a beta prototype because:

1. The prototype was not fabricated using production tooling such as jigs and fixtures;
2. The prototype was to be handed to the customer if it were to pass verification trials.

6.3.2.2.2 The Validation Test of the Maize Dryer Beta Prototype

6.3.2.2.2.1 Background

In February 2006, a customer inquiry was received from a milling company for a product that can be used to dry soaked maize grains used in maize meal production – the drying process should not cook the maize. A physical prototype had been manufactured during the last quarter of 2008 and was undergoing verification trials during the study practical trip of January – June 2009. The physical prototype provided a means for developing an empirical model; the following design for experiment exercise was undertaken since there was an acknowledgement that the prototype was not meeting the targets set out in the product design specification (PDS).

6.3.2.2.2.2 Objectives

- 1 To determine the drying capacity;
2. To investigate the suitability of the prime mover;
3. To propose the correct rotational speed of the drum;
4. To study the effect, on both output and power requirements, of changing the following parameters:
 - 4.1. Drum Rotational Speed;

- 4.2. Air Temperature;
- 4.3. Air Flow rate;
- 4.4. Maize Feed Mass;
- 4.5. Drum Diameter; and
- 4.6. Drum Sieve Size;
- 5. To develop empirical models.

6.3.2.2.2.3 Apparatus

The following apparatus were used: T500K Thermocouple, 0 – 200mm Vernier Calliper, Multi Meter, T4201 Anemometer with Vane Probe, MT665 Digital Hygrometer, Tachometer, METTLER PJ3000 Analytical Balance, Stop Watch; and RIPC0 (B) Rotary Dryer

6.3.2.2.2.4 Theory

Cereal Drying is the removal of moisture (expressed as a percentage of mass of dry material) from within cereal crop by vaporization – requiring the effective usage of heat to alter the temperature and humidity of the air that the cereal crop is exposed to (Equation 41).

$$\% \text{ Moisture Content} = \frac{\text{Mass of Moisture in Cereal}}{\text{Mass of Dry Cereal Material}}$$

Equation 41: Moisture Content

An Equilibrium Moisture Content would be reached whereby the cereal crop neither losses nor gains moisture from the air; the temperature and humidity of the air are vital parameters as they determine the extent of moisture removal, therefore the humidity chart is important when designing cereal dryers.

Within the cereal crop, the moisture may be free in-between the cereal crop grains (i.e. in excess of equilibrium moisture content) or bound in cell walls (hence exerting a vapour pressure higher than that of free water). Moisture is first removed by diffusion into the air stream to give a constant rate of drying – the rate falls as the moisture is removed from within the grain.

6.3.2.2.2.5 Procedure

3.1. Preparation

- 3.1.1. Obtain a 50 litre container with no leakage;
- 3.1.2. Put 25 kg or 50 kg of decorticated maize in the container;
- 3.1.3. Pour water on the maize in the container until full to the bream;
- 3.1.4. Leave mixture to soak over two nights;

3.2. Trials

- 3.2.1. Using a strainer, drain excesses water from the maize and spread it over the container;
- 3.2.2. Ensure that the machine is not powered in anyway;
- 3.2.3. Open the top drum door to check that there is nothing inside the machine;
- 3.2.4. Move the belts by hand to check mis-alignment;
- 3.2.5. Fill the drum with drained maize to ensure that equilibrium moisture content is reached;
- 3.2.6. Power the machine;

6.3.2.2.2.6 Result and Analysis

3.3. Capacity

The performance of the Maize Dryer is as tabulated below (Table 49):

Time (hr)	Dry Mass (kg)	Moisture Content (%)	Output (kg/h)
2	25	38.8	12.5
5	50	35	10
Average			11.25

Table 49: Output Rate of the Maize Dryer

3.4. Power Requirements

The heater drew an on-load, line voltage of 379.3 V, the fan drew 216.8 V and the main motor drew 218.5 V. It was, however, impossible to measure the line current due to defective multi-meter:

3.5. Effect of Air Temperature and Air Flow-rate

➤ Effect on Capacity

The model variables and their boundaries were chosen as in Table 50:

	Variable	Target	Lower Bound (-)	Upper Bound (+)
P	% Change Moisture Reduction	32.0%		
d_1	Air Temperature		35 °C	41 °C
d_2	Air Flowrate		2.2 m/s	3.3 m/s

Table 50: The Model Variables and their Boundaries

Four trials were run based on a 2^2 experimental setup and assuming a multi-linear model (Table 51).

Trial	d ₁	d ₂	P
1	-1	-1	1.9
2	1	-1	3.9
3	-1	1	2.2
4	1	1	4.2

Table 51: Experimental Set-Up

The Analysis of Variance for the effect of these changes on the output is shown in Table 52 which indicates that the effect of changing air temperature on output is 44 times more than the effect of changing the air flowrate and the effect of the interaction between two variables is insignificant.

ANOVA

Source of Variation	SS	df	MS	F	P-value	F crit
Temperature	4	1	4	9.01E+15	6.71E-09	161.4476
Flowrate	0.09	1	0.09	2.03E+14	4.47E-08	161.4476
Temperature X Flowrate	4.44E-16	1	4.44E-16			
Total	4.09	3				

Table 52: Analysis of Variance

➤ **Empirical Model for Capacity**

Using regression analysis, a mathematical model can be developed using MSeXcel giving Equation 42 below:



Equation 42: Mathematical Model of the Maize Dryer

6.3.2.2.2.7 Conclusion

The output rate of the Maize Dryer is 11.25 ± 1.25 kg/h. This output rate was very small and will not meet the targets set product design specifications which are used to develop verification trials plans.

6.3.2.2.3 The Proof-of-Concept Validation Test of the Maize Dryer Prototype

6.3.2.2.3.1 Background

It was observed that in generally, the trend at RIPCO (B) has been to fabricate a Beta Prototype and assume it to be both the Pre-Production Prototype and Actual Product i.e. to have no corrections needed in the Beta Prototype even if there have been no proof-of-concept prototypes. This may result in disastrous consequences. From the project file, it was established that on a previous occasion another design engineer had designed and manufactured a tray dryer which did not functionally work (Figure 108).

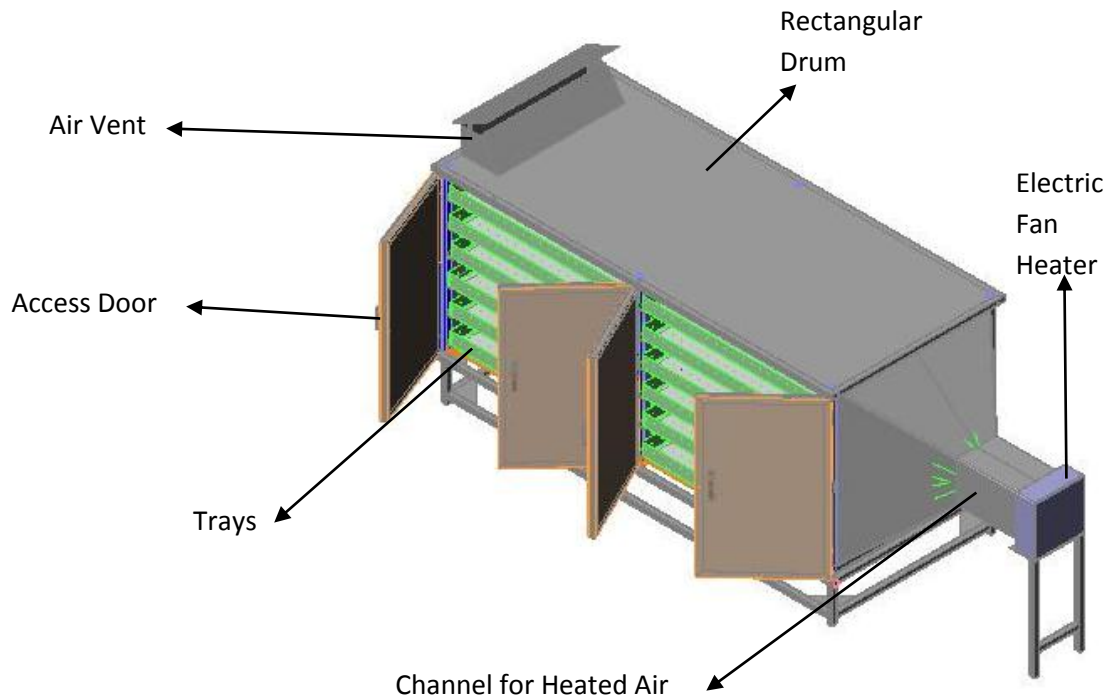

Figure 108: Maize Tray Dryer Prototype (Source: Project Design Office)

6.3.2.2.3.2 Objectives:

This observation stated above led to the examination of the physics of dryers with the goal of establishing functional feasibility, to determine if the current prototype can be modified to satisfy the customer needs. The intention was not to make any radical changes to the existing prototype therefore architectural or module interfacing was critical. It must be noted that the product design guidelines were not as developed and entrenched to require the establishment of the general functional block diagram. Attention was given to establishing an analytical prototype of the existing maize dryer.

6.3.2.2.3.3 Theory

Air properties are important for drying grain. Since the moisture holding capacity of air increases as the temperature of air increases, heat may be added in grain drying to help reduce moisture from grain kernel. Air provides the connection between the mechanical equipment use in grain drying and controls of such equipment because the air properties have an effect on the outcome of the drying process.

There are three definitions used to describe air under various conditions:

1. Atmospheric Air: Contains Carbon Dioxide, Oxygen, Nitrogen and contaminants such as water vapour, dust, pollen and smoke;
2. Dry Air: A condition where the water vapour and other contaminants have been removed from atmospheric air; and

3. Moist Air: A condition in which dry air is mixed with water vapour although moist air is usually used to refer to atmospheric air for practical purposes.

Psychrometrics refers to the properties of moist air. A psychrometric chart graphically illustrates mainly the relationship between air temperature and relative humidity (Figure 109). A better understanding of air properties and the psychrometric chart can help in the design of a grain drying product.

To understand the psychrometric chart, it is necessary to isolate the various lines and scales.

Firstly, air temperature is a measure of the heat content of the air. The psychrometric chart uses three types of air temperatures:

1. Dry Bulb Temperature which can be measured by ordinary thermometer and is generally given by weather reports. In a psychrometric chart, the dry bulb temperature scale is typically located at the base and vertical lines (Figure 109) indicate a constant dry bulb temperature;
2. Wet Bulb Temperature which reflects the cooling effect of evaporating water and can be measured by passing the air over an ordinary thermometer that has been wrapped with a small amount of moist cloth. This cooling effect of water causes a lower temperature compared to the dry bulb temperature. In a psychrometric chart, the wet bulb temperature scale is typically located on the curved, upper left portion and the sloping lines (Figure 109) indicate a constant wet bulb temperature; and
3. Dew Point Temperature is the temperature below which water vapour will condense out of air. Air that is holding as much water vapour as possible is saturated and it is at its dew point. For a grain drying product, water will condense on the surface of the grain if the grain is at or below the dew point temperature of the air. In the psychrometric chart, the dew point temperature is located along the wet bulb temperature scale; however, the horizontal lines (Figure 109) indicate equal dew point temperature.

Secondly, relative humidity is a measure of how much moisture is present compared to how much moisture the air can hold at that temperature. The relative humidity is expressed as a percentage and is normally given in weather reports. Arc lines with differing curvatures and covering the area between the dry bulb temperature and the wet bulb temperature are used to represent conditions of equal relative humidity (Figure 109). The arc line showing 100% relative humidity and representing air saturation coincides with both the wet bulb temperature and the dew point temperature scale lines. The line of 0% relative humidity coincides with the dry bulb temperature scale line.

Finally, this psychrometric chart shows the scales for enthalpy of saturation with an associated humidity ratio. The humidity ratio can be expressed as the ratio between

the actual mass of water vapour present in moist air to the mass of the dry air (Equation 43).

$$\omega = \frac{m_{\text{water-vapour}}}{m_{\text{dry-air}}}$$

Where ω = Humidity Ratio of Drying Air

$m_{\text{water-vapour}}$ = Mass of Water Vapour in the Drying Air passing through the Seed Bed

$m_{\text{dry-air}}$ = Temperature of Drying Air passing through the Seed Bed in $^{\circ}\text{C}$

Equation 43: Humidity ratio of Drying Air

In psychrometric, enthalpy may be defined as a measure of the total energy in the air. The specific enthalpy of drying air is the total enthalpy of dry air and moist air mixture per unit mass of moist air. The enthalpy of saturation consists of sensible heat and latent heat and is useful for calculating cooling and heating processes. Sensible heat is energy required to change the temperature of an object whilst latent heat is the energy required to change the state of an object and cannot be observed as a temperature change. Equations 44 – 49 relate to the enthalpy as used with the psychrometric chart.

$$Q_{\text{drying-air-sensible-heat}} = m_{\text{drying-air}} C_{\text{dry-air}} \Delta T_{\text{drying-air}}$$

Where $Q_{\text{drying-air-sensible-heat}}$ = Sensible Heat of the Drying Air passing through the Seed Bed

$m_{\text{drying-air}}$ = Mass of Drying Air passing through the Seed Bed

$C_{\text{dry-air}}$ = Specific Heat Capacity of the Drying Air passing through the Seed Bed i.e. the amount of heat required to change one gram of the drying air;

$\Delta T_{\text{drying-air}}$ = Change in Temperature of the Drying Air passing through the Seed Bed

Equation 44: Sensible Heat

But,

$$C_{\text{dry-air}} \approx 1.006 \frac{\text{kJ}}{\text{kg}} ^{\circ}\text{C} \quad \text{for } -100 ^{\circ}\text{C} < T < 100 ^{\circ}\text{C}$$

Equation 45: Specific Heat of Capacity for Drying Air

and

$$h_{\text{dry-air}} = C_{\text{drying-air}} T_{\text{dry-air}} = 1.006 T_{\text{dry-air}}$$

Where $h_{\text{drying-air}}$ = Specific Enthalpy of Dry Air (without any Moisture)

$T_{\text{drying-air}}$ = Temperature of Dry Air (without any Moisture) in $^{\circ}\text{C}$

Equation 46: Specific Enthalpy of Drying Air

and,

$$h_{\text{water-vapour}} = C_{\text{water-vapour}}T_{\text{water-vapour}} + h_{\text{water-vapour-evaporation-heat}}$$

Where $h_{\text{water-vapour}}$ = Specific Enthalpy of Water Vapour

$C_{\text{water-vapour}}$ = Specific Heat of Water Vapour

$T_{\text{water-vapour}}$ = Temperature of Water Vapour in $^{\circ}\text{C}$

$h_{\text{water-vapour-evaporation-heat}}$ = Evaporation Heat of Water at 0°C

Equation 47: Specific Enthalpy of Water Vapour i.e. Latent Heat of Water Vapour

with,

$$C_{\text{water-vapour}} \approx 1.84 \frac{\text{kJ}}{\text{kg}} ^{\circ}\text{C} \text{ and } h_{\text{water-vapour-evaporation-heat}} \cong 2501 \frac{\text{kJ}}{\text{kg}}$$

Equation 48: Specific Heat of Capacity and Evaporation Heat for Water Vapour

Since,

$$h = h_{\text{drying-air}} + \omega h_{\text{water-vapour}} \approx 1.006T_{\text{drying-air}} + \omega(1.84T_{\text{water-vapour}} + 2501)$$

Where h = Specific Enthalpy of the Drying Air Passing the Seed Bed

ω = Humidity Ratio

Equation 49: Specific Enthalpy of Drying Air

It must be noted that the enthalpy would be 0 kJ/kg at 0°C . According the definition of enthalpy in the thermodynamics, this is not correct but for practical purposes in air psychrometric this assumption is good enough since our interest is the enthalpy difference.

In addition to air properties, the moisture content of the grain which are being dried should be recorded. This will give an indication of the tendency for moisture to diffuse into the drying air. Moisture would diffuse from the region of high moisture content to a region of low moisture content. Typically, the moisture content of the grain is determined in two ways (Equation 50 and Equation 51):

$$M_{\text{wet-basis}} = \frac{m_{\text{final-grain-mass-after-soaking}} - M_{\text{dry-grain-mass}}}{M_{\text{final-grain-mass-after-soaking}}} \times 100\%$$

Where $M_{\text{wet-basis}}$ = The moisture content wet basis is the ratio of the increase in the weight of the solid due to soaking and the final weight due soaking

$m_{\text{final-grain-mass-after-soaking}}$ = The mass of the grains after they have been soaked

$m_{\text{dry-grain-mass}}$ = The mass of the grains before soaking

Equation 50: Moisture Content (Wet Basis)

$$M_{\text{dry-basis}} = \frac{m_{\text{final-grain-mass-after-soaking}} - m_{\text{dry-grain-mass}}}{m_{\text{dry-grain-mass}}} \times 100\%$$

Where $M_{\text{dry-basis}}$ = The moisture content wet basis is the ratio of the increase in the weight of the solid due to conditioning and the initial weight before soaking

Equation 51: Moisture Content (Dry Basis)

Carrier
PSYCHROMETRIC CHART
 HIGH TEMPERATURES
 SI METRIC UNITS
 Barometric Pressure 101.325 kPa
 SEA LEVEL

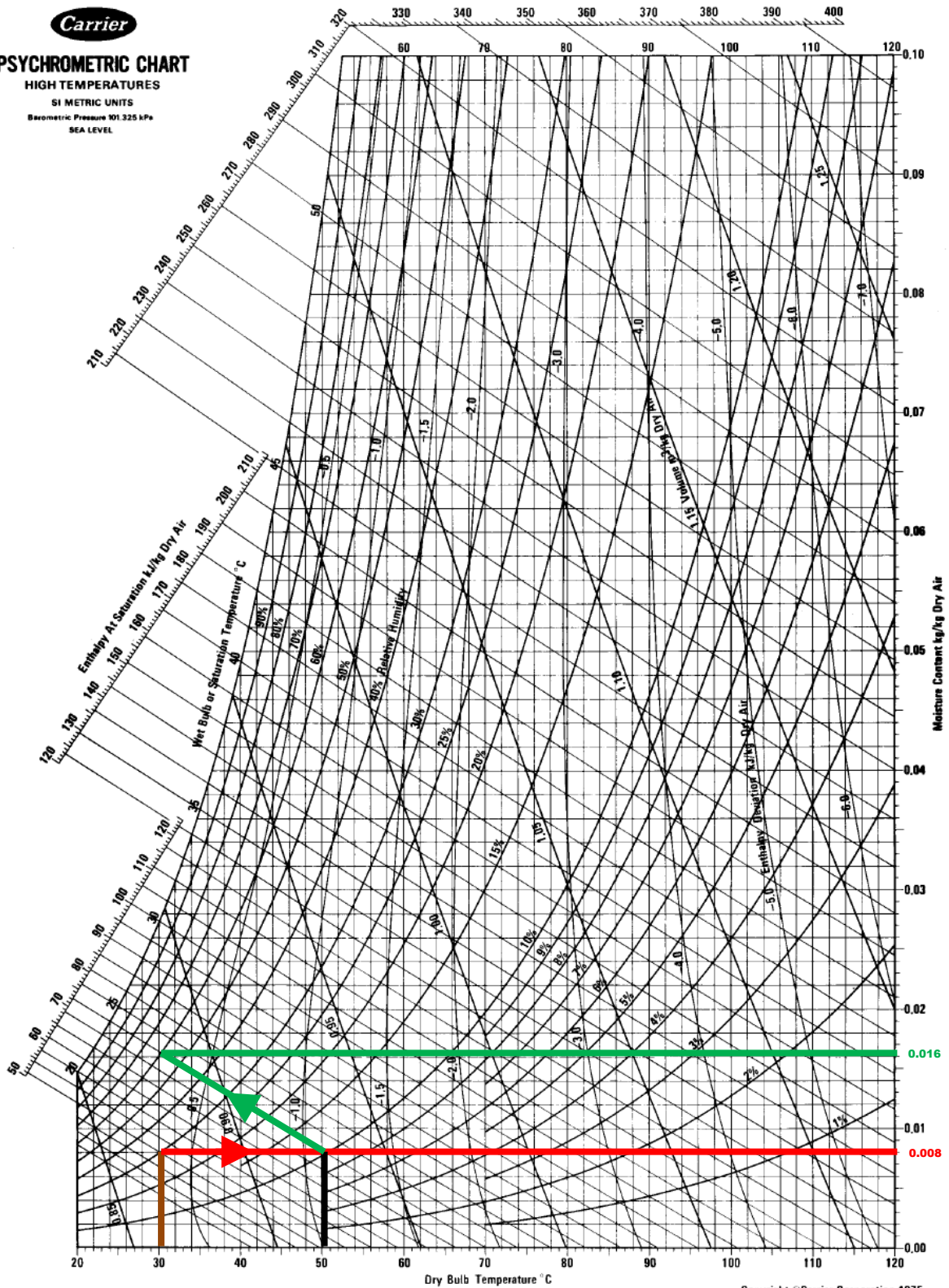

Copyright ©Carrier Corporation 1975
 Cat. No. 794-005 Printed in U.S.A.

Figure 109: Psychrometrics Chart (Source: ASAE D271.2 DEC94 (ASAE Standard 1998) Accessed on <http://www.ecaa.ntu.edu.tw/weifang/ebook/psy-data1998.pdf>)

6.3.2.2.3.4 Modifications to the Maize Dryer Prototype that was manufactured in 2008 (Figure 105 and 106)

With an understanding of the physics of the dryer, stepwise modifications which would see the maize dryer prototype be transformed through the six classes of prototypes from proof-of-concept to pre-production were organised. The results from testing the beta prototype showed that air temperature and air flow rate play a critical role in this kind of a dryer. The following modifications were instituted:

1. The first modification was to ensure that the highest possible temperature could reach each maize grain without cooking it. The cap on the inner drum which was the side that was away from the electric motor was replaced with a hub and six spoke. The main shaft that drives the inner drum would pass through hub and the spokes would connect it to rest of the inner drum. A casing was designed that would enclose electric heating elements. The casings was comprised of two similar components; one smaller and nested on the other. An insulation material would be fitted between the nested casings. This work had to be done with the help of mechanical engineers at both the design office and the manufacturing workshop.

The electric fan heater was stripped of the six elements which were then fixed on the casing; a second electric fan heater was sought from the store-room and was also stripped to increase the number of elements which were fixed on the casing to twelve. These were fixed in pairs that were 60° away from one another and covering a breadth of the inner casing. The elements were wired on the outward side of the inner casing (Figure 110). Insulation material was laid to protect the bare wires and the outer casing was positioned with more insulation material packed in. A user interface with the set of buttons obtainable the stripped fan heaters was developed. The heating setting range was the same as with unstripped fan heater that had been used in the prototype before; there were twelve electrical heating elements with the buttons controlling sets of three elements. This work had to be done with the assistance of the electrical and electronic engineer.



Figure 110: Heating Elements Casing

2. A large propeller fan with a diameter equal to the inner casing in which the heating elements had been fixed was designed. The fan was made from an aluminium sheet and had five blades. It was designed using SolidWorks™ 3D modelling software in the product design office. This enabled the development drawings to be made and saved in dxf. format for storage and processing by the plasma cutter in the manufacturing workshop.

The maize dryer incorporating these modifications was assemble and may be described as consisting of the following four functional sub-assemblies (Figure 111):

- The Aeration Module: This is comprised of two sub-assemblies: The propeller fan sub-assembly and the heating elements casing.
 - The Propeller Fan Sub-Assembly: This is responsible for blowing air at atmospheric pressure and temperature into the drying drum through the heating elements casing. It is provided with a safety guard and is painted red to indicate danger to the operator;
 - The Heating Element Casing: This consists of twelve electrical heating elements which are controlled through the user interface. The air that is blown by the propeller fan passes through these heating elements where the air is conditioned (i.e. changes to air temperature and humidity) before entering into the rotating inner drying drum;
- The Processing Module: This is physically manifested as a drying drum and is comprised of a rotating inner drum made from perforated sheet with four buffers and an outer stationary drum made from galvanised mild steel sheet. The inner drum has a door to allow for access to put soaked maize.
- The Separation Module: The top part of the outer drum has an opening which regulates the flow rate of air and another opening at the bottom which acts as an outlet. There was no immediate need for designing a more elaborate separating sub-assembly such as a cyclone;
- The Power Module which is comprised of two electrical motors and two three phase power supply sockets that supply the heating elements.

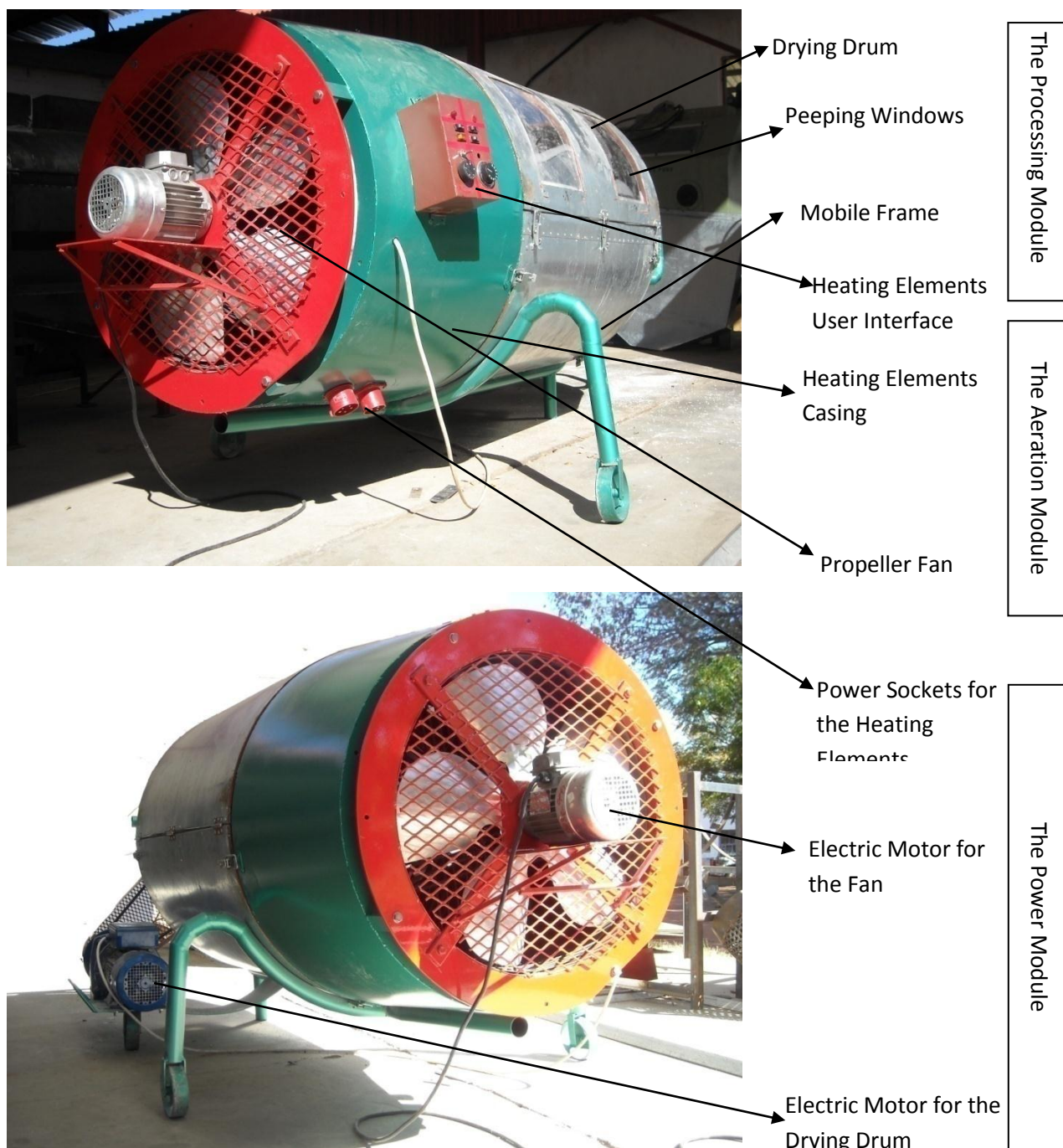

Figure 111: The Modified Maize Dryer Proof-of-Concept Prototype

6.3.2.2.3.5 Result and Analysis

The maize kernels were weighed before and after soaking to enable the determination of both wet basis and dry basis moisture content (Table 53).

Mass of Dry Maize Kernels (kg)	25
Mass of Soaked Maize Kernels (kg)	34.3
Increase of Mass of the Maize Kernels due to Increased Moisture Content (kg)	9.3

Table 53: Weight of the Maize Kernels before and after Soaking

From Equation 50, the wet basis moisture content of the maize kernels is (Equation 52):

$$M_{wet-basis} = \frac{9.3}{34.3} \times 100\% = 27.1\%$$

Equation 52: Moisture Content (Wet Basis) of Maize Kernels

From Equation 51, the dry basis moisture content of the maize kernels is (Equation 53):

$$M_{dry-basis} = \frac{9.3}{25} \times 100\% = 37.2\%$$

Equation 53: Moisture Content (Dry Basis) of Maize Kernels

The psychrometric chart was instrumental in the modification introduced to the design of the proof-of-concept maize dryer prototype (Section 6.3.3.2.3.5) because most of the other properties of moist air can be determined from just the air temperature and the relative humidity.

With the introduction of the air directly into the inner drum of the dryer, the following processes may be used to explain the psychrometric chart of the proof-of-concept maize dryer prototype (Figure 109):

Conditions of the Atmospheric Air (shown by the line coloured brown in Figure 109): The dry bulb temperature of the air as affected by the weather elements at the start of the trial was 30.8 °C with a relative humidity of 30 %.

When compared with the wet basis moisture content of the maize kernels of 37.2 % (Equation 53), a relative humidity of 30% indicates a possibility of some transfer of moisture from the maize kernels to the atmospheric air if it is blown without it being heated. The dry basis moisture content of the maize kernels of 27.1 % (Equation 52) indicates the opposite tendency.

The psychrometric chart indicates that the wet bulb temperature and the dew point temperature of the atmospheric air with a relative humidity of 30 % are below 20 °C and the enthalpy at saturation is 50 kJ/kg.

Sensible Heating (shown by the line coloured red in Figure 109): During this process the moisture content remains constant and the temperature increases. This process occurs in the aeration module. The atmospheric air is blown by the propeller fan without any addition of water. The air temperature after heating increased from 30.8 °C to 50 °C and, according to the psychrometric chart, the relative humidity dropped to 10 %.

When compared with both the wet basis moisture content and dry basis moisture content of the maize kernels (Equation 52 and Equation 53), a relative humidity of 30% indicates an increased capacity to transfer moisture from the maize kernels to

the air if it is blown when there is a drop in relative humidity due to increased air temperature.

The psychrometric chart indicates that the wet bulb temperature and the dew point temperature of the atmospheric air with a relative humidity of 10 % is 24 °C and the enthalpy at saturation is 73 kJ/kg.

Cooling and Humidification (shown by the line coloured red in Figure 109):

During this process the air temperature drops and its humidity increases and this occurs in the inner drum; this is because the temperature of the maize kernels is lower and its moisture content is extremely high compared to the air being blown into the inner drum. Also the inner drum is rotating at 14 rpm and is fitted with four buffers that lift the maize kernels from the bottom most position – this increases the surface area of the maize grains in contact with the heated air.

6.3.2.2.3.5 Discussion and Recommendations

It is very clear from the psychrometric chart that there is sensible heat transfer from the air to the maize kernels and latent heat transfer from the water within the mass of maize kernels to the air:

- If the temperature of the maize kernels was equal to the wet bulb temperature of the air i.e. 24 °C, then the net heat transfer would be zero as the sensible heat from the air to the maize kernels would be equal to the latent heat from the water in the maize kernels to the air.
- If the temperature of the water in the maize kernels is greater than the wet bulb temperature, then the net heat transfer would be from the maize kernels to the air due to latent heat transfer from the maize kernels being greater than sensible heat transfer from the air; and
- On the other hand, the opposite holds true if the temperature of the maize kernels is the wet bulb temperature of the air.

However, the goal for this proof-of-concept prototype was not to check for these; these should be checked as part of the design for experiments experimental prototype.

The proof-of-concept prototype was progressed into an industrial design prototype. Two large peeping windows on the outer drum allow the operator to view the inner drum during drying. A three legged mobile frame made from a mild steel pipe supports the outer drum, the heating elements casing and the propeller fan. Two of the hind legs are fitted with small wheels to allow for mobility. The front leg is directly connected to a pull handle. There was no opportunity to develop design for experiments experimental prototype as the modified maize dryer was handed to the customer.

Both the grain drying and grain milling products have been worked on in this study as part of the Integrated Support for Arable Agriculture Development (ISPAAD) and Young Farmers Fund (YFF) Programme; a grain dryer whose design parameters were more synchronised with other grain storage and processing products was designed and it benefited from work done on the maize dryer prototypes.

6.4 Critical Evaluation of the Product Design Guidelines

In this section, the main objective is to present aspects of optimising the product design guidelines (PDG) having learnt from the industrial case applications. Training on, and implementation of, the PDG is key. It is also of paramount importance to have determined and willing resources that deliberately coordinate their efforts to using the product design process as a central and unifying theme.

The investigations have revealed that the approach to engineering product design currently used in Botswana may benefit from emphasis on the following issues:

- The design teams should expend more effort into the product design drivers in order to gain a full understanding of the users and the context of the technological application before starting to physical embodiment design. The case studies indicate that such an approach was beneficial to logically solve the problems relating to the maize dryer. During the case study work, the product realisation activities of the maize dryer only went as far as proof-of-concept prototype;
- The relevant mathematical and engineering relationships should be established early as part of the design activity to minimise the tendency to rely heavily on learning from full size physical prototypes, which is a costly and inefficient approach;
- Techniques such as failure mode and effect analysis (FMEA) should be encouraged before prototype manufacturing;
- In order to facilitate the culture of productivity, there is a general requirement to have a single conceptual framework, such as that of the PDG, to improve the visibility of institutional activities;
- Backups are an integral part of the design activity;
- Ensuring the product design will be appropriate for the needs of the users and also for manufacture in the most appropriate regions. This has been amply demonstrated particularly by the design of the sorghum dehulling products;
- Assisting design teams to use a wide range of known and successful design methods effectively at the most appropriate stages of a project, hence supporting effective project management and training. The PDG do not enforce the use of particular methods but allow the designers to choose those they believe are most suitable.

The PDG have been developed as a comprehensive and universal approach intended to impart these benefits and to develop products which are synchronised

with the national policy implementation efforts and address the basic needs of the peoples in the LDC. The case studies have been used to demonstrate the benefits of the PDG in practice up to the stage of Design Rule 9. Modularisation and the use of common platforms and sub-systems would be a major factor in the development of successful products and systems for Botswana. The PDG, as demonstrated by the grain production and processing equipment, facilitate a modular design approach and in-depth consideration of commonality in the use of sub-systems.

The products involved in the case studies were not pre-selected to constrain the formulation and application of the PDG to real life situations. The PDG have made a positive input to the development of these products and proposes one way to provide the much needed solutions to the least economically developed countries (LDC). The PDG are informed by nine successful product design methods documented in literature and three research, science, technology and innovation institutions (RSTI) in Botswana including Progressive Sports Ltd and Loughborough University in the United Kingdom (UK). It must be stated from the onset that, owing to the number of products in these case studies, the PDG are still theoretical and may need to be improved upon.

The PDG are meant to impart some key dimensions of the product design process including the following main characteristics:

6.4.1 The Value of Structured Product Design Methods

According to Martin (2007) structured methods have a formal methodology that is visible to external observers and “make the analytical judgement transparent” thereby providing these observers with capacity to perform an audit trail. Suh (1990) specifies that design has four aspects: problem definition, creative process, analytical process and ultimate check; these four aspects being visualised as a feedback control loop which ensures capability to analyse the quality of the creative process. The PDG currently have a designer’s toolkit comprising forty-two techniques. The execution of these techniques involves creative and conceptual stages which are highly interconnected and may even progress through reversible, iterative workflows as required by product development lifecycles and registered by product design method notation. Product design requires capability to both forecast and think ahead and returning to put current activities into perspective. The power and utility of a structured approach is that, by following a well defined method, it is possible to re-consider or perform re-works with high precision because the analytical process has been documented and is therefore accessible (Ritchie and Spencer, 2002).

The product design method used for the case study work allowed for the finalisation of the maize dryer within a three months period at RIPCO (B).

6.4.2 The Visibility obtainable from the establishment of a Culture of Productivity in the implementation of Product Design Activities

“A large body of evidence indicates that distinctive cultures that dramatically influence performance do exist” according to Saffold (1988). Shenhav et. al (1989) argue that productivity is a phenomenon which takes on various meanings in different contexts. Organisations offer incentives to employees who measure up to the definition of productivity as restricted to its business goals.

This level of achievement is greatly enhanced by a “visible operational structure.” Visibility helps employees and customers to realise the role performed by everybody. Organisational structures must be visible because product design activity is inevitably intertwined with the business design activity (Pugh, 1991).

6.4.3 The Clarification of the Link between National Policies, Programmes, Projects, Products, Sub-Assemblies and Components

The structuring of product design such that it becomes visible is aided by the adoption of a configuration scheme that provides the link between policies, programmes, projects and products. To this end, a group of products that share the same human and non-human resources in an organisation is referred to as a project; a programme is a group of projects that share a common pool of institutions; and a policy is implemented through a group of programmes.

6.5 Summary

In this chapter, the PDG have been applied in practice to a number of design projects in Botswana. These enabled the evaluation of the process through the stages from the product design drivers to physical prototyping.

Step-by-Step application of the PDG has been explained and the Design Rules 1 to 9 have been described in relation to national infrastructure and to the product design case studies covering grain or food production and processing and a selection proposal for a streetlight concept.

The benefits and value of the methodology have been summarised.

Chapter 7: Conclusions, Recommendations and Suggestions for Future Work

7.1 Conclusions

The aim of this research was to investigate ways by which the engineering product design process could be improved for Botswana and other LDC in similar situations. The difficulties currently experienced during design in Botswana are outlined in section 1.1. The development of new product design guidelines (PDG) was identified as a means of addressing the problems by facilitating design practice within the RSTI and also perhaps, in the future, improving design education. A holistic and flexible approach would be essential. It was found to be necessary to consider not only the design of the hardware component of products, but also the soft systems such as the political and regional infrastructure in which the products would be manufactured and used. Botswana has a small population but is a very well organised society and any changes in the approach used for product design must be compatible with expected developments at a national level, such as Vision 2016 and the National Development Plans.

The product design guidelines were developed by encompassing established design methods and theory from countries in the northern hemisphere and these were placed within a new conceptual framework which facilitates design practice and also relates the design process to organisational and political infrastructure of a country.

The research findings demonstrate that product design methods have the following five key characteristics:

1. The divergent – convergent structure;
2. The need – function – form structure;
3. The product development lifecycles
4. The product design drivers; and
5. The product realisation process

The divergent – convergent structure has led to formulation of twelve design rules; whilst the need – function – form structure establishes three types of attributes. Techniques that are used in product design operate twelve rules to manipulate the three types of attributes. Based on the types of attributes involved, a technique may be referred to as divergent or convergent.

Based on these characteristics, the possibility to develop the product design guidelines was explored. The product design guidelines formulated in this research are comprised of:

1. Conceptual Framework;
2. Product Design Method Notation; and
3. Configuration Scheme

The product development lifecycle directs the workflow for operating the activities through the techniques specified in the conceptual framework.

The product design method notation was found to assist in quick selection and communication of techniques in the conceptual framework. It assumes the conceptual frameworks to be a Cartesian co - ordinate system; two co – ordinates are used to specify the location of the techniques. One co - ordinate specifies the location along an axis defined by the need – function – form structure; the other co – ordinate specifies location along the divergent – convergent axis.

The configuration scheme helps the designer or design team to identify national policies, programmes, projects, sub-assemblies and components associated with the product they are about to design. This is critical for resource allocation.

Application of the PDG and the relationships with organisational infrastructure and national policy have been demonstrated by the case studies. The findings have shown that the new methodology can save time (maize drier), can facilitate effective design evaluation (street light) and additionally enables clear documentation of the full design process. The design guidelines were shown to be flexible and not prescriptive as the framework allows different combinations of techniques to be used without losing the benefits of the overall methodology.

An original aim of this research was the development of product design guidelines to assist in overcoming problems in Botswana and other least economically developed countries (LDC). The Conceptual Framework developed to integrate design methodologies for the benefit of design teams in Botswana is, however, universal and may be beneficial for design projects in economically developed countries as well as the LDC.

The aims of the research have been achieved through the development of the product design guidelines. The research questions have been addressed and the two hypotheses have been validated by means of case studies.

7.2 Recommendations

It is recommended that more education and implementation of the product design guidelines be undertaken especially in research, science, technology and innovation institutions of the least economically developed countries. This research was undertaken in collaboration with Ministry of Infrastructure, Science and Technology in Botswana. The ministry oversees the operation of three institutions: the Botswana Technology Centre, The National Food Technology Research Centre and the Rural industries Promotions Company (Botswana). Although only the product design specifications were completed, the projects that were researched are useful and needed in Botswana. It would be beneficial to complete the development work using the product design guidelines.

The sponsorship for this research was through the “Training of Scientists and Technologists” pilot project. This thesis would provide valuable input towards the evaluation the pilot project.

7.3 Suggestions for Future Work

The aim of this research was to create a sound basis for appropriate design guidelines. It would be impossible for the guidelines to be in their final form within a four year period and further work is will be necessary before the methodology can be applied in practice.

The research methods used in this study relied mostly on interpretation or subjective decision making by the researcher. Although some objectivity was factored in, quantitative research methods still need to be utilised to validate the product design guidelines.

There was also the question of resources available for case study work. This was conducted in a setup that required industrial case applications in a least economically developed country. Supporting resources were found to be lacking in some instances.

As at the end of May 2011, the product design guidelines had forty – two techniques. Owing to fact that the sample of institutions surveyed in this research is small, it is difficult to state that the conceptual framework is complete. One other factor contributing to this is that the conceptual framework has a lot more techniques than any of the product design methods utilised in the institutions that were surveyed. It is therefore suggested that more work be undertaken by other researchers to address this situation.

References

1. Acquah, B., 2003. Making Technologies Work for the Resource-Poor Farmers in Botswana, *Pula: Botswana Journal of African Studies*. Gaborone, Botswana: Pula
2. Aganga, A, and Tsopito, C., n.d. Donkey Power Technology in the Gaborone Region of Botswana. In: P. Starkey and D. Fielding, n.d. e.d. Donkeys, People and Development. Wageningen, The Netherlands: Animal Traction Network for Eastern and Southern Africa, pp. 158 - 161

[accessed at <http://www.atnesa.org/donkeys/donkeys-aganga-gender-BW.pdf> in May 2008]

3. Ahmed, P., 1998. Culture and Climate for Innovation, *European Journal of Innovation Management*. Oxford, United Kingdom: Emerald Group Publishing Group, 1 (1), pp. 30 - 43
4. Ahn, Y., and Lee, K., 2006. Application of Axiomatic Design and TRIZ in Eco-Design, *The TRIZ Journal*. Washington, United States of America: CTQ Media
5. Akao, Y., 1990. An Introduction to Quality Function Deployment. In: Y. Akao, ed. 1990. *Quality Function Deployment: Integrating Customer Requirements into Product Design*. New York, United States of America: Productivity Press.
6. Akao, Y., Harada, A., and Matsumoto, K., 1990. Quality Function Deployment and Technology Deployment. In: Y. Akao, ed. 1990. *Quality Function Deployment: Integrating Customer Requirements into Product Design*. New York, United States of America: Productivity Press.
7. Akin, G. And Hopelain, D., 1986. Finding the Culture of Productivity, *Organisational Dynamics*. 14 (3), pp. 19 - 32
8. Amber, S., 2005. *A Manager's Introduction to The Rational Unified Process (RUP)* Ambysoft Copyright
9. Ansari, A., and Modareess, B., 1994. Quality Function Deployment, *Journal of Supply Chain Management*. New Jersey, United States of America: John Wiley and Sons Inc, 30 (4), pp. 27 – 35.
10. Apley, D., Jun, L., and Chen, W., 2006. Understanding the Effects of Model Uncertainty in Robust Design with Computer Experiments, *Journal of Mechanical Design*, Nevada, United States of America: ASME. 128, pp. 945 – 958
11. Asheim, B., 2002. Industrial Districts: The Contributions of Marshall and Beyond. In: G., Clark, M., Feldman and M., Gertler, ed. 2002. *The Oxford*

Handbook of Economic Geography. Oxford, United Kingdom: Oxford University Press

12. Auditor General, 2001. *Performance Audit Report No. 1: Management of ALDEP II.* Gaborone, Botswana: Ministry of Finance and Development Planning,
13. Bainer, R., Kepner, R., and Barger, E., 1955. *Principles of Farm Machinery.* New Jersey, United States of America: Wiley
14. Baker, D., and Siebert, J., 1986. Farming Systems Activities at Mahalapye: Summary 1982 – 85, *ATIP Research Report Number 1.* Gaborone, Botswana: ATIP
15. Baxter, M., 2002. *Product Design: Practical Methods for the Systematic Development of New Products.* Cheltenham, United Kingdom: Nelson Thornes
16. Beaton, G., 1980. *Mind and Nature.* New York, United States of America: Bantam Books
17. Beintema, N., M., Modiakgotla, E., and Mazhani, L., M., 2004. Botswana. *ASTI Country Report No. 19.* Washington DC: United States of America: IFPRI
18. Bhushan, N., 2007. Set-Based Concurrent Engineering and TRIZ: A Framework for Global Product Development, *The Proceedings of TRIZCON 2007.* Bangalore, India: Wipro Technologies
19. Blanchard, B., and Fabrycky, W., 2006. *System Engineering and Analysis.* New Jersey, United States of America: Prentice Hall
20. Bloch, P. H., 1995. Seeking the Ideal Form: Product Design and Consumer Response. *Journal of Marketing.* 59 (3) pp. 16 – 29
21. Boehm, B, 1988. A Spiral Model of Software Development and Enhancement, *Computer.* IEEE 21(5) pp. 61 - 72
22. Botswana Government, 1991. *National Policy on Agricultural Development.* Gaborone, Botswana: Botswana Press Agency
23. Botswana Government, 2009. *National Development Plan 10.* Gaborone, Botswana: Botswana Press Agency
24. Botswana Technology Centre, 1998. *Science and Technology Policy for Botswana.* Gaborone, Botswana: Botswana Press Agency

25. Bouchereau, V., and Rowlands, H., 2000. Methods and techniques to help Quality Function Deployment, *Benchmarking: An International Journal*. Oxford, United Kingdom: Emerald Group Publishing Group, 7 (1), pp. 8 - 20
26. Brown and Allport, 2010. *Developing Products with "Added Value"*. In: P. Harpum, 2010. *Portfolio, Program and Project Management in the Pharmaceutical and Biotechnology Industries*. New Jersey, United States of America: John Wiley and Sons Inc
27. Browning, T., R., 2001. Applying the Design Structure Matrix to System Decomposition and Integration Problems: A Review and New Directions. *IEEE Transactions on Engineering Management* 48 (3) pp. 292 - 306
28. Case, J., Chilver, L., and Ross, C., 1983. 3rd ed. *Strength of Material & Structures: With an Introduction to Finite Element Methods*. London, United Kingdom: Edward Arnold
29. Chanda, W., 1999. Technology Design and Manufacture - The Technology Transfer Programme in Botswana, *Appropriate technology for small and medium enterprises in SADC countries : papers presented to the workshop of the SEPAC Working Group "Information, Technology and Technology Transfer", Kanye, 2-3 November 1998*. Bonn, Germany: Friedrich-Ebert-Stiftung, p 58 – 64 ISBN 99912-916-5-2
30. Changeta, N, 2003. The Technology Based Incubation in Botswana, *Regional Workshop on Technology Based Incubators in SADC Countries: 24 – 28 February 2003*
31. Chikofsky, E., and Cross, J., 1990. Reverse Engineering and Design Recovery: A Taxonomy, *IEEE Software*. Ottawa, Canada: IEEE Software Society, 7 (1), pp. 13 - 17
32. Chiou, W., Kuo, H., and Lu, I., 1999. Technology Oriented Productivity Measurement Model, *International Journal of Production Economics*. Amsterdam, The Netherlands: Elsevier 60 – 61, pp. 69 – 77
33. Clausing, D., and Andrade, R. ed., 1996. *Creative Innovative Products using Total Design: The Legacy of Stuart Pugh*. Massachusetts, United States of America: Addison – Wesley Inc
34. Cooper, R., 1990. Stage – Gate Systems: A New Tool for Managing New Products, *Business Horizons*. Indiana, United States of America: The Kelly School of Business

35. Crispin, H., 1987. *Analysis of the Engineering Design Process in an Industrial Context*. Selwyn, United Kingdom: Gants Hill Publications
36. Cross, N., 1994. *Engineering Design Methods: Strategies for Product Design*. West Sussex, United Kingdom: John Wiley & Sons
37. Coulson, J., and Richardson, J., 1993. 2nd ed. *Chemical Engineering* Oxford, United Kingdom: Pergamon Press L.t.d., 6
38. Criscuolo, A., and Palmade, V., 2008. How Did the Most Successful Developing Countries Organise Themselves at the Outset?, *FIAS Policy Note N. 3* Washington DC, United States of America: World Bank
39. Cutherell, D., 1996. Product Architecture. In: M. Rosenau ed. *The PDMA Handbook of New Product Development*. New York, United States of America: John Wiley and Sons
40. Davis, J., B., C., 1983. Integrating Design and Manufacture, *Efficiency in the Design Office*, June, p.15 – 20
41. Dean, F., Bentz, B., and Bahill, T., 1997. *A Roadmap for Implementing System Engineering* California, United States of America: Sandia National Laboratories
42. Department of Defense, 2001. *Systems Engineering Fundamentals*. Virginia, United States of America: Defense Acquisition University Press
43. Devarajan, S., Easterly, W., R., and Pack, H., 2001. Is Investment in Africa Too Low or Too High? Macro and Micro Evidence *Policy Research Paper No. 2519*. Washington DC: United States of America: The World Bank Development Research Group, Public Economics and Macroeconomics and Growth
44. Dixon, J., 1966. *Design Engineering*. New York, United States of America: McGraw – Hill
45. Domb, E., and Kling, T., 2006. How to Reduce Cost in Product and Process using TRIZ, *The TRIZ Group* Michigam, United States of America: trizgroup.com
46. Dyer, B., Gupta, A., and Wilemono, D., 1999 What First-to-Market Companies Do Differently, *Research Technology Management*. Arlington, United States of America: Industrial Research Institute, Inc,
47. Dym, C., Agigono, A., Eris, O., Frey, D., and Leifer, L., 2005. Engineering Design Thinking, Teaching and Learning, *Journal of*

Engineering Education. Georgia, United States of America: American Society for Engineering Education pp. 103 - 120

48. Edosomwan, J., 1987. *Integrating Productivity and Quality Management*. New York, United States of America: Marcel Dekker Inc

49. Evans, B., 2000. *The Requirements Engineering Process for Custom and COTS Based Systems*, [presentation material from Lockheed Martin, Management and Data Systems]

[Accessed from www.incose.org/delvalley/031400r1.pdf]

50. Ezzy, D., 2001. Are Qualitative Methods Misunderstood? *Australian and New Zealand Journal of Public Health* Melbourne, Australia: The Public Health Association of Australia Inc. 25 (4) pp. 294 - 297

51. Fagnoli, M., Roviola, E., and Troisi, R., 2006. The Morphological Matrix: Tool for the Development of Innovative Design Solutions, *Proceedings of ICAD 2006 4th International Conference on Axiomatic Design in Firenze June 13 – 16 2006*. Firenze, Italy

52. Forsberg, K., and Mooz, H., 1995. *The Relationship between System Engineering and the Project Lifecycle*. California, United States of America: Center for Systems Management

53. Foster, R., *Timing Technological Transitions Technology in the Modern Corporation: A Strategic Perspective*, Pergamon Press, Inc 1986

54. Fraser, G. and Mabusela, L., 2003. Sustainability of Traditional Agriculture in the Southern African Savannas of Botswana, *South African Geographical Journal*. Pretoria, South Africa: Sabinet, 85 (1), pp. 11 - 17

55. Frey, D, Wijnia, Y., Katsikopoulos, K., Herder, P., Subrahmanian, E., Clausing, P., 2007. An Evaluation of the Pugh Controlled Convergence Method. *Proceedings of the ASME DETC Conference*. Nevada, United States of America: ASME.

56. Gaury, E., and Kleinjnen, J., 1998. Risk Analysis of Robust System Design, In: D. Medeiros, E., Watson, J., Carson, and M., Manivannan, ed. 1998 *Proceedings of 1998 Winter Simulation Conference*. New Jersey, United States of America: Institute of Electrical and Industrial Engineers, pp. 1533 - 1540

57. Glass, A., J., and Saggi, K., 1998. International Technology Transfer and the Technology Gap, *Journal of Development Economics*. Amsterdam, The Netherlands: Elsevier pp. 369 -398

58. Gonzalves-Coelho, A., 2004. Axiomatic Design and the Concurrent Engineering Paradigm, *Proceedings of the Computing and Solutions in Manufacturing Engineering*. Brasov, Romania: COSME
59. Grandstrand, O., 1998. Towards a Theory of the Technology-Based Firm, *Research Policy*. Amsterdam, The Netherlands: Elsevier, 29, pp. 1061 - 1080
60. Green, P., E., and Krieger, A., M., 1991. Segmenting Markets with Conjoint Analysis, *Journal of Marketing* Chicago, United States of America: American Marketing Association 55 pp. 20 - 31
61. Griffin, A., and Hauser, J., R., 1993. The Voice of the Customer. *Marketing Science*. 12 (1) pp. 1 – 27
62. Griffin, A., and Page, A., 1993. An Interim Report on Measuring Product Development Success and Failure, *Journal of Product Innovation Management*. Philadelphia, United States of America: Wiley – Blackwell, 10 (4), pp. 291 – 308
63. Guenov, M., and Barker, S., 2005. Application of Axiomatic Design and Design Structure Matrix to the Decomposition of Engineering Systems, *Systems Engineering*. Philadelphia, United States of America: Wiley Online Library, 8 (1), pp. 29 – 40
64. Halevi, G., *Handbook of Production Management Methods*. Massachusetts, United States of America: Elsevier Butterworth-Heinemann 2001
65. Harb, J., N., Durrant, S., O., and Terry, R., E., 1993. Use of the Kolb Learning Style and the 4MAT System in Engineering Education, *Journal of Engineering Education*. Washington DC, United States of America: American Society for Engineering Education 82 (2) pp. 70 - 77
66. Harzing, A., 2010. *The Publish or Perish Book: Your Guide to Effective and Responsible Citation Analysis*. Melbourne, Australia: Tarma Software Research Pty Ltd
67. Henderson, R., M., and Clark K., B., 1990. Architectural Innovation: The Configuration of Existing, *Administrative Science Quarterly*. New York, United States of America: S. C. Johnson Graduate School of Management 35 pp. 9 - 30
68. Hipple, J. 2006. *The Use of TRIZ Principles in Consumer Product Design, Proceedings of TRIZCON2006*. Milwaukee, United States of America: Altshuller Institute

69. Horvath, I., 2004. A Treatise on Order in the Engineering Design Research, *Research in Engineering Design*. London, United Kingdom: Springer – Verlag 15, pp. 155 - 181
70. Houshmand, M., and Jamshidnezhad, B., n.d., *Redesigning of an Automotive Body Assembly Line through an Axiomatic Design Approach*
[accessed from www.ifm.eng.cam.ac.uk/mcn/pdf_files/part8_2.pdf]
71. Horvath, I., 2004. A Treatise on Order in the Engineering Design Research, *Research in Engineering Design*. London, United Kingdom: Springer – Verlag 15, pp. 155 - 181
72. Howard, 1970.
73. Hubberman, M., A., and Miles, M. B., 2002. *The Qualitative Researcher's Companion* California, United States of America: Sage Publications
74. Hubka, V., and Eder, W., E., 1988. *Theory of Technical Systems*. Berlin, Germany: Springer
75. Imai, M., 2006. 5th ed., Chapter 8 Measurement, Analysis and Improvement. In: D. Hoyle, 2006. *ISO 9000: Quality Systems Handbook*. Massachusetts, United States of America: Elsevier Butterworth-Heinemann
76. Institute of Electrical and Electronics Engineering, 1994. *IEEE Std 1220 IEEE Standard for Application and Management the Systems Engineering Process*. New York, United States of America: IEEE
77. Inger, D., 1993. Poverty and Profits: The Work of RIPCO GTZ GATE Eschborn, Germany: Deutsche Gesellschaft fur Technische Zusammenarbeit 4
78. Jacobs, J., 1969. *The Economy of Cities*. New York, United States of America: Random House
79. Jayanti, S., Kalyanaraman, Y., Iyer, N., and Ramani, K., 2006. Developing an Engineering Shape Benchmark for CAD Models. *Computer Aided Design* 38 pp. 939 – 953
80. Jefferis, K., n.d. The New Policy on Small, Medium and Micro Enterprises, *BIDPA Briefing*. Gaborone, Botswana: Botswana Institute for Development Policy Analysis (BIDPA), ISSN 1560-5817
81. Justel, D., Vidal, R., and Chiner, M., 2006. TRIZ Applied to Innovate in Design for Disassembly, *The 13th CIRP International Conference on Life Cycle Engineering*. Paris, France: CIRP

82. Karlstrom, D., and Runeson, P., 2005. Combining Agile Methods with Stage – Gate Project Management, *IEEE Software*. Ottawa, Canada: IEEE Software Society, 22 (3), pp. 43 - 49
83. Keatimilwe, K., 2005. *Botswana National Research Science and Technology Plan*. Stellenbosch, South Africa: Council for Scientific and Industrial Research
84. Kgathi, D., Sekhwela, M., and Hamandawana, H., n.d. Sustainability of Commercial Agriculture and Forestry in Chobe District, Botswana, *South African Geographical Journal*. Pretoria, South Africa: Sabinet
- [accessed from
<http://www.savannas.net/botswana/ubforst.html#Acknowledgements>]
85. Lara, M., Witzerman, J., and Nof, S., 2000. Facility Description Language for Integrating Distributed Designs, *International Journal of Production Research*. Oxford, United Kingdom: Taylor & Francis, 38 (11), pp. 2471 to 2488
86. Laswai, H., Shayo, N., and Kundi, S., 2003. Collaborative Project to Investigate Consumer Preferences for Selected Sorghum and Millet Products in the SADCC Region of Africa. In: P. Belton and J. Taylor, 2003. *Conference Proceedings of the Afripro Workshop on the Proteins for Sorghum and Millets: Enhancing Nutritional and Functional Properties for Africa*. Pretoria, South Africa: Afripro
87. Laws, S., Harper, C., and Marcus, R., 2003. *Research for Development*. London, United Kingdom. Sade Publication
88. Lee, H., and Billington, C., 1994. Designing Products and Processes for Postponement. In: S., Dasu, and C., Eastman, *Management of Design: Engineering and Management Perspectives*. Massachusetts, United States of America: Kluwer Academic Publishers, pp. 105 - 122
89. Lemons, G., Carberry, A., Swan, C., Jarvin, L., and Rogers, C., 2010. The Benefits of Model Building in Teaching Engineering Design, *Design Studies*. Amsterdam, The Netherlands: Elsevier 31 (3) pp. 288 - 309
90. Leon-Rovira, N., 2002. A Proposal to Integrate TRIZ into the Product Design Process, *The TRIZ Journal*. Washington, United States of America: CTQ Media
91. Lewis, P. R., 2000. *Polymer Product Failures*. Shropshire, United Kingdom: iSmithers RAPRA Technologies LTD

92. Livingstone, I., 1980. *Alternative Approaches to Small Industry Promotion: Tanzania, Kenya and Botswana*, *Centre of African Studies Conference on Industrialisation in Africa Edinburgh Nov 30 – Dec 1st 1979* Norwich, United Kingdom: School of Development Studies
93. Long, J., 2002. *Relationships between Common Graphical Representations in Systems Engineering*. Virginia, United States of America: Vitech Corporation
94. Martin, S., 2007. Intelligence Analysis: Structured Methods or Intuition?, *American Intelligence Journal*, Virginia, United States of America: National Military Intelligence Association, pp. 7 -16
- [Accessed on <http://www.scribd.com/doc/48430001/Marrin-Intell-Analysis-Structured-Methods-or-Intuition-AIJ-2007-5> on 18 July 2011]
95. Madhusudan, T., 2005. An Agent – Based Approach for Coordinating Project Design Workflows, *Computers in Industry*. Amsterdam, The Netherlands: Elsevier, 56, pp. 235 – 259
96. Marshall, A. 1890. 8 ed. *Principles of Economics*. London, United Kingdom: Macmillan and Co
- [accessed from <http://www.econlib.org/library/Marshall/marP.html>]
97. McAdams, D., Stone, R., and Wood, K., 1999. Functional Interdependence and Product Similarity Based on Customer Needs, *Research in Engineering Design*. London, United Kingdom: Springer-Verlag, 11, pp. 1 – 19.
- [accessed from http://www.md.kth.se/mmk/gru/mme/mf2011/CourseMaterial/Seminar2/2_4_7N2UMCR981LJDA3Q.pdf]
98. Ministry of Commerce and Industry, 1999. *Policy on Small, Medium and Micro Enterprises in Botswana*. Gaborone, Botswana: Department of Information and Broadcasting
99. Ministry of Finance and Development Planning, 1997. *National Development Plan 8*. Gaborone, Botswana: Government Printer
100. Ministry of Finance and Development Planning, 2002. *National Development Plan 9 (2003 – 2009)*. Gaborone, Botswana: Department of Information and Broadcasting, pp. 121 - 122
101. Mmapatsi, M. D., and Maleke, J., M., 1996. Development of an Institutional Support Systems for Sorghum Milling Technology, *Drought Tolerant Crops for Southern Africa: Proceedings of the SADC/ICRISAT Regional Sorghum and Pearl Millet Workshop, 25-29 Jul 1994*.

International Crops Institute for Semi-Arid Tropics. Bulawayo, Zimbabwe: Socioeconomics and Policy Program pp. 7 - 18

102. Moore, G. 1991a. *Crossing the Chasm: Marketing and Selling High – Tech Products to Main Stream Customers*. New York, United States of America: Harper Business Essentials
103. Moore, G. 1998b. 2ed. *Crossing the Chasm* West Essex, United Kingdom: Capstone
104. Moyo, R., 1999. Technology Transfer and SMME Promotion through the Village Skills Training Programme in Botswana, *Appropriate technology for small and medium enterprises in SADC countries : papers presented to the workshop of the SEPAC Working Group "Information, Technology and Technology Transfer", Kanye, 2-3 November 1998*. Bonn, Germany: Friedrich-Ebert-Stiftung, 1999 p 58 – 64 ISBN 99912-916-5-2
105. Naddeo, A., 2006. Axiomatic Framework Applied to Industrial Design Problem Formulated by Para-Complete Logics Approach: The Power of Decoupling on the Optimization – Problem Solving, *Proceedings of ICAD 2006 4th International Conference on Axiomatic Design in Firenze June 13 – 16 2006*. Firenze, Italy
106. National Aeronautics and Space Administration, 1995. *Systems Engineering Handbook SP-610S*. Washington, D. C., United States of America: NASA
107. Nepal, B., Monplaisir, L., and Singh, N., 2006. A Methodology for Integrating Design for Quality in Modular Product Design, *Journal of Engineering Design*. Oxford, United Kingdom: Taylor & Francis
108. North Star INCOSE Chapter Meeting, 2008. *Functional Analysis and Decomposition*. Wisconsin, United States of America: Armstrong Process Group
109. Norton, R., 1996. *Machine Design: An Integrated Approach* New Jersey, United States of America: Prentice-Hall
110. O'Connor, P., 1994. From Experience Implementing a Stage – Gate Process: A Mulyi – Company Perspective, *Journal of Product Innovation Management*. Philadelphia, United States of America: Wiley – Blackwell, 11, pp. 183 - 200
111. Oladele, O. and Monkhei, M., 2009. Structural Changes in Livestock Marketing Cooperatives in Botswana: A Two Decades Analysis, *Livestock Research for Development*. Cali, Colombia: CIPAV, 21 (6)

112. Oliver, David Timothy P. Kelliher, and James G. Keegan, Jr. 1997. *Engineering Complex Systems with Models and Objects*. McGraw-Hill
113. Otto, K., and Antonsson, K., 1991. Extension to the Taguchi Method of Product Design, *ASME Journal of Mechanical Design*. United States of America: ASME
- [accessed from <http://design.caltech.edu/Research/Publications/90f.pdf>]
114. Otto and Wood 1999. Customer Integration Systematic Design, *Journal of Integrated Design and Process Science*. Amsterdam, The Netherlands: IOS Press 3 (4) pp. 61 - 74
115. Otto, K., N., and Wood K., L., 2001. *Product Design: Techniques in Reverse Engineering and New Product Development*. New Jersey, United States of America: Prentice-Hall
116. Pahl, G., and Beitz. W., 1996. *Engineering Design: A Systematic Design*. Translated from German by Ken Wallace, Lucienne Blesing and Frank Bauert London, United Kingdom: Springer
117. Pelotona, S., 2005. The Development of a Dehuller: A case of Rural Industries Promotion Company, *Proceedings of a Conference for Agricultural Research and Development in Botswana*. Sebele, Botswana: Botswana Agricultural Research Information Network (BARIN),
118. Pelt, A., and Hey, J., 2006. Using TRIZ and Human Centered Design for Consumer Product Development, *Procedia Engineering*. Amsterdam, The Netherlands: Elsevier, 9, pp. 688 - 693
119. Penny, R., 1970. Principles of Engineering Design, *Postgraduate Medical Journal*. London, United Kingdom: BMJ 46, pp. 344 - 349
120. Peters, T., 2006. 5th ed., Chapter 5 Management Responsibility. In: D. Hoyle, 2006. *ISO 9000: Quality Systems Handbook*. Massachusetts, United States of America: Elsevier Butterworth-Heinemann
121. Pimmler, T., and Eppinger, S., 1994. Integration Analysis of Product Decompositions, *Proceedings of the 6th International Conference on Design Theory and Methodology*. Minneapolis, United States of America: ASME, 68, pp. 343 - 351
122. Porter, M., 1990. *The Competitive Advantage of Nations*. London, United Kingdom: Macmillan

123. Porter, M., 1991. Towards a Dynamic Theory of Strategy, *Strategic Management Journal (1986 – 1998)*, New Jersey, United States of America: John Wiley and Sons, Ltd., 12, pp. 95 - 117
124. Prasad, B., 2000. A Concurrent Function Deployment Technique for a Work-Group-Based Engineering Design Process, *Journal of Engineering Design*. London, United Kingdom: Taylor and Francis, 11 (2), pp. 103 - 109
125. Pugh, S., 1991. *Total Design: Integrated Methods for Successful Product Engineering*. Reading (MA), United States of America: Addison-Wesley Publishing Company
126. Quality Office, 2010. *ISO 9000: 2000 Quality System Documentation Manual for RIPCO(B)*. Kanye, Botswana: Information Office
127. Ritchie, J., and Spencer, L., 1994. Qualitative Data Analysis for Applied Policy Research. In: Hubberman, M., A., and Miles, M. B., 2002. *The Qualitative Researcher's Companion* California, United States of America: Sage Publications
128. Rohrbach D., Mupanda, K., and Seleka, T., 2000. Commercialisation of Sorghum Milling in Botswana. *International Crops Institute for Semi-Arid Tropics*. Bulawayo, Zimbabwe: Socioeconomics and Policy Program
129. Rohrbach, D., and Kiriwaggulu, J., 2007. Commercialisation Prospects for Sorghum and Pearl Millet, *Open Access Journal published by ICRISAT*. Bulawayo, Zimbabwe: Socioeconomics and Policy Program
130. Romesburg, H., C., 1984. *Cluster Analysis for Researchers*. California, United States of America: Lifetime Learning Publications
131. Rosenberg, N., 1976. On Technological Expectations, *The Economic Journal*. New Jersey, United States of America: Wiley-Blackwell Publishing 86 (343) pp. 523 - 535
132. Ross, P., 1996. *Taguchi Techniques for Quality Engineering: Loss Function, Orthogonal Experiments, Parameter and Tolerance Design*. New York, United States of America: McGraw-Hill
133. Roth, D., 2005. The Emergence of Competitors to the Science Citation Index and the Web of Science, *Current Science*. Bangalore, India: Indian Academy of Sciences 89 (9) pp. 1531 - 1536

134. Saffold, G., 1988. Culture Traits, Strength, and Organisational Performance: Moving Beyond “Strong” Culture, *Academy of Management Review*. New York, United States of America: Academy of Management
135. Salter, C., Sami, S., Bruce, S., and Jim, W., 1998. Towards a Secure System Engineering Methodology, *Proceedings of the New Security Paradigms Workshop*. Santa Cruz, United States of America: ACM Press
136. Schmidt, O., G., 1987. The Sorghum Dehuller: A Case Study in Innovation *International Institute for Environment and Development's Conference on Sustainable Development* London, England
137. Schumacher, E., F., 1973. *Small is Beautiful: A Study of Economics as if People Mattered*. London, United Kingdom: Blond and Briggs
138. Scott, A., 1997. The Cultural Economy of Cities, *Journal of Urban and Regional Research*. Massachusetts, United States of America: Blackwell Publishers, 21, pp. 323 - 339
139. Selaolo, E., 2007. The National System of Innovation *Presented at the Innovation Forum*, Dublin: 6 – 8 March
140. Sekwati, L., 2011. Botswana: A Note on Diversification, *Botswana Journal of Economics*. Gaborone, Botswana: Botswana Economics Association
141. Sharp, J., E., Harp, J., N., and Terry, R., E., 1997. Combining the Kolb’s Learning Styles and Writing to Learn in Engineering Classes, *Journal of Engineering Education*. Washington DC, United States of America: American Society for Engineering Education 86 (2) pp. 93 – 101
142. Shenhav, Y., Habberfeld, Y., and Cohen, B., 1989. Contextual Analysis of the Team Productivity in the R&D Industry, *Scientometrics*. Budapest, Hungary: Akademiai Kiado, 17 (5 – 6), pp. 387 - 400
143. Shippen, J., and Turner, J., 1966a. Basic Farm Machinery. Oxford, United Kingdom: Pergamon Press, Vol 1
144. Shippen, J., and Turner, J., 1966b. Basic Farm Machinery. Oxford, United Kingdom: Pergamon Press, Vol 2

145. Segler, G., 1951. *Pneumatic Grain Conveying with Reference to Agricultural Application*. Silsoe, United Kingdom: National Institute Agricultural Engineers
146. Sosa, M., Eppinger, S., and Rowles, C. 2004. The Misalignment of Product Architecture and Organisational Structure in Complex Product Development, *Management Science*. Pennsylvania, United States of America: University of Pennsylvania, 50 (12), pp. 1674 - 1689
147. Sroufe, R., Curkovic, S., Montabon, F., and Melnyk, S., A., 2000. The New Product Design Process and Design for the Environment: "Crossing the Chasm", *International Journal of Operations Management*. Edinburgh, United Kingdom: University Press 20 (2) pp. 267 – 291
148. Starkey, P., 1988. *Animal Drawn Wheeled Toolcarriers: Perfected yet Rejected*. Lengrerich, Germany: Vieweg & Sohn
149. Steward, D. V., 1981. The Design Structure Matrix: A Method for Managing the Design of Complex Systems. *IEEE Transactions on Engineering Management* 28 pp. 71 – 74
150. Steward, D. V., 1981. *Systems Analysis and Management: Structure, Strategy and Design*. New York, United States of America: PBI
151. Stice, J., E., 1987. Using the Kolb's Learning Cycle to Improve Student Learning, *Journal of Engineering Education*. Washington DC, United States of America: American Society for Engineering Education
152. Suh, N., P., 1990. *The Principles of Design*. New York, United States of America: Oxford University Press
153. Suh, N., P., 1995. Designing-in of Quality through Axiomatic Design. *IEEE Transactions on Reliability*, 44 (2) pp. 256 – 264
[Access from 18.7.29.232/bitstream/handle/1721.1/25610/Suh-1995-Designing-in.pdf?sequence=1 on 17 May 2011]
154. Sussman, G., 2007. *Building Robust Systems: An Essay*. Massachusetts, United States of America: Massachusetts Institute of Technology,
- [accessed from citeseekx.ist.psu.edu/viewdoc/download?doi=10.1.1.113.1324&rep=rep1&type=pdf]
155. Szykman, S., Sriram, R., D., Bocheneck, C., Racz, J., W., and Senfaute, J., 2000. Design Repositories: Engineering Design's New

- Knowledge Base. *IEEE Intelligent Systems and their Applications*, 15 (3) pp. 48 – 55
156. Tagwa, B., 2005. Planter Development at the Rural Industries Innovation Centre, *Proceedings of a Conference for Agricultural Research and Development in Botswana*. Sebele, Botswana: Botswana Agricultural Research Information Network (BARIN),
157. Takai, S. 2005. Inference of Population Hierarchical Cluster of Customer Needs *Proceeding of International Design Engineering Technical Conferences and Computer and Information in Engineering*. California, United States of America: ASME
158. Tang, J., Zheng, Y., Tu, Y., Chen, Y., and Dong, Y., 2005. Synthesis, Evaluation and Selection of Parts Design Scheme in Supplier Involved Product Development, *Concurrent Engineering: Research and Applications*. California, United States of America: Sage Publications, 13 (4), pp. 277 – 290.
159. Teng-Zeng F. 2007. Botswana, *Baseline Study on Science and Technology Framework and Higher Education in the SADC Region*. Johannesburg, South Africa: SARUA Publications
160. Terniko, J., 1997. 2 ed. Step by Step QFD: CustomerDriven Product Design. Saint Lucie Pr
161. Thoben, K., Eschenbacher, J., and Jaddev, H., 2001. Extended Products: Evolving Traditional Product Concepts, *Proceedings of the 7th Conference on Concurrent Engineering 27 – 29 June*. Bremen, Germany, pp. 429 – 439
162. Togo, K., 2008. Development Assistance and Economic Growth: A Case Study of Botswana, *Musashi University Discussion Paper No. 48*, Tokyo, Japan: National Graduate Institute for Policy Studies
163. Transparency International, 2009. *Global Corruption Report 2009: Corruption and the Private Sector*. New York, United States of America: Cambridge University Press
164. Turton, R., Bailie, R., Whiting, W., and Shaeiwitz, J., 2003. *Analysis, Synthesis and Design of Chemical Processes*. New Jersey United States of America: Prentice Hall
165. Ulrich, K., and Tung, K., 1991. Fundamentals of Product Modularity, *Proceedings of the 1991 ASME Winter Annual Meeting Symposium*. Georgia, United States of America: ASME

166. Ulrich, K., 1995. The Role of Product Architecture in the Manufacturing Firm, *Research Policy*. Amsterdam, The Netherlands: Elsevier 24 (3), pp. 419 - 440
167. Ulrich, K., and Eppinger, S., 2003. 3rd ed. *Product Design and Development*. New York, United States of America: McGraw-Hill
168. van Wyk, R., 1985. The Notion of Technological Limits: An Aid to Technological Forecasting, *Futures*. Massachusetts, United States of America: Elsevier Butterworth & Co (Publishers) Ltd
169. Vision 2016 Taskforce, 1997. *A Framework for a Long Term Vision for Botswana*. Gaborone, Botswana: Botswana Department of Information and Broadcasting
170. Whitby, G., 1985. Intermediate Technology Research in Botswana, *Research for Development in Botswana. Proceedings of a Symposium held by the Botswana Society at the Gaborone Sun Conference Centre August 19 – 21 1985*. Gaborone, Botswana: The Botswana Society
171. Whiteside, M., 1997. *Encouraging Sustainable Family Sector Agriculture in Botswana*. Gaborone, Botswana: Cooperation for Research, Development and Education (CORDE)
172. Whitfield, R., Wright, P., Coates, G., and Hills, W., A Robust Design Methodology suitable for Application to One-Off Products, *Journal of Engineering Design*. Oxford, United Kingdom: Taylor & Francis, Vol. 9, No. 4, 1998
173. Wood, K., L., Jensen, D., Bezdek, J., and Otto, K., N., 2001. Reverse Engineering and ReDesign: Courses to Incrementally and Systematically Teach Design, *Journal of Engineering Education*. Washington DC, United States of America: American Society for Engineering Education 90 pp. 363 – 374
174. Wood, K., L., and Linsey, J., S., 2007. Understanding the Art of Design: Tools for the next Edisonian Innovators, *The Psychology of Learning and Motivation*. Amsterdam, The Netherlands: Elsevier 47 pp. 65 – 122
175. Xu, Q, Jiao, R., Yang, X., and Helander, M., 2008. An Analytical Kano Model for Customer Need Analysis, *Design Studies*. Amsterdam, The Netherlands: Elsevier 30 pp. 87 – 110

176. Yang, K., and Zhang, H., 2000. A comparison of TRIZ and Axiomatic Design, *The TRIZ Journal*. Washington, United States of America: CTQ Media
177. Zeng, Y., 2001. *Axiomatic Approach to Modelling of Product Conceptual Design Processes using Set Theory*. Ph. D. The University of Calgary
178. Zwicky, F., 1948. The Morphological Method Analysis and Construction, *Courant*. New York, United States of America: Interscience Publishers, Anniversary Volume, pp. 461 – 470.

Bibliography

1. Agriculture Engineering *Structure of New AEL Academic Programmes* Gaborone, Botswana: Botswana College of Agriculture, 2007
2. Anderson, P., and Tushman, M. 1990. Technological discontinuities and dominant designs: a cyclical model of technological change, *Administrative Science Quarterly*. 35 (4) pp. 604 - 634
3. Bahill, T., 2001. *What is Systems Engineering? A Consensus of the INCOSE Fellows*
4. Bonk, Curtis and Dennen, Vanessa *Frameworks for Research, Design, Benchmarks, Training, and Pedagogy in Web-Based Distance Education, Frameworks for Research* pp. 339 - 346
5. Bryman, 2004 *A Social Research Methods* Oxford, United Kingdom: Oxford University Press
6. Corbetta, P., 2003. *Social Research: Theory, Methods and Techniques*. London, United Kingdom: Sage,
7. Dillman, D., 2000. *Mail and Internet Surveys: The Tailored Design Method*, London, United Kingdom: John Wiley and Sons
8. Floyd, J., and Fowler, J., R., *Survey Research Methods*, London, United Kingdom: Sage, 2002
9. Groenewald, T., 2004. A Phenomenological Research Design Illustrated, *International Journal of Qualitative Methods*. Florida, South Africa: University of South Africa
10. Groves, R., 2004. *Survey Methodology*, London, United Kingdom: Wiley
11. Huang, G., 1996. *Design for X: Concurrent Engineering Imperatives*. London, United Kingdom: Chapman and Hall
12. Insight.mas *A White Paper on Research Sampling*, July 2005
13. Krick, E., 1969. 2nd ed. *An Introduction to Engineering and Engineering Design*. New York, United States of America: John Wiley and Sons, Inc,
14. Metzler, Dianne and Davis, Patricia *Employing a Mixed-Mode Qualitative Research Method Prior to Conducting Quantitative Research* Arkansas, United States of America: University of Arkansas at Little Rock

15. Moore, N., 2006. *How to do Research: A Practical Guide to Designing and Managing Research Projects*. London, United Kingdom: Facet Publishing
16. Muzumder, C., 2004. *Robust Design: Uncertainty Representation and Propagation* India: Indian Institute of Technology, 2004.
17. Projects Design Office, 2007. *Weekly Plans for the Period 04 January 2005 to 19 October 2007*. Kanye, Botswana: Information Unit,
18. Projects Design Office, 2007. *Quarterly Plans for the Period January - March 2005 to October – December 2007*. Kanye, Botswana: Information Unit
19. Punch, K., 2006. 2nd ed. *Developing Effective Research Proposals*. London, United Kingdom: SAGE Publishing
20. Question Bank, *Methods of Data Collection in Social Sciences*. Economic and Social Research Council
21. RIPC(B) Management *RIPC(B) 2008. Annual Calendars of Events 2003 to 2008* Gaborone, Botswana: Information Unit
22. RIPC(B) Management, 2002. *RIPC(B) Strategic Plan 2003/04 to 2008/09*. Gaborone, Botswana: Information Unit
23. Sapsford, R., 1999. *Survey Research* London, United Kingdom: Sage
24. The Design-Based Research Collective, 2003. Design Based Research: An Emerging Paradigm for Educational Inquiry, *Educational Researcher*. Pennsylvania, United States of America: Pennsylvania State University, 32(1) pp. 5 - 8
25. University of Botswana Calendar 2006

Websites

1. gd.tuwien.ac.at/systemeng/bahill/whatis/whatIs.doc accessed on June 2008
2. gd.tuwien.ac.at/systemeng/bahill/slides/similar.ppt accessed on June 2008
3. www.bca.bw
4. www.bidpa.bw
5. www.creativeandlive.com/archives/2008/05/27/origin-and-history-of-a-word-design accessed in June 2008
6. www.dezignare.com/definition.html accessed in June 2008
7. www.gov.co.com
8. www.moa.gov.bw
9. www.msct.gov.bw
10. www.naftec.co.bw
11. www.jeckle.de/files/uniproc.pdf accessed on Sunday, June 2008
12. www.incose.org/practice/fellowsconsensus.aspx accessed on June 2008
13. www.triz-journal.com/archives/what_is_triz/ accessed in May 2008
14. www.ub.co.bw

Appendix 1: Exploratory Data on Research, Science and Technology Institutions in Botswana

Product Method	Institution
Machinery Design	UB, RIPCO(B), BOTEC, DAR and BCA
Plant/Process (Engineering) Design	UB, RIPCO(B), BCA and NFTRC
Incubation	RIPCO(B)
Electrical Component Design	UB and BOTEC
Incorporated Technology	Institution
Renewable Energy Systems (Solar and Wind)	UB, RIPCO(B) and BOTEC
Draught Power	DAR, RIPCO(B) and BCA
Biomass	RIPCO(B) and BCA
Design Tool	Institution
CNC programming (Lathe & Milling)	UB and RIPCO(B)
3-D solid modeling CAD tool for Part and Assembly	UB, RIPCO(B) and BOTEC
2-D solid modeling CAD tool for Part and Assembly	UB, RIPCO(B), BOTEC and DAR
Numerical and Graphical Modeling Software for Synthesis of Mechanisms	UB
3-D Shape Accuracy Testing	UB
Rapid Prototyping	UB
Analytical Testing	UB and NAFTRC

Continues Next Page . . .

Appendix 1: Exploratory Data on Research, Science and Technology Institutions in Botswana (Cont...)

	Institution Name	Research Nature	Employee Number	Year of Establishment	Research Mandate
1	University of Botswana, (UB)	Tertiary Education	827 (15725 students (2830 in research, science and technology))	1982	Academic Research
2	Botswana College of Agriculture, (BCA)	Tertiary Education	.	1991	Academic Research
3	Rural Industries Promotions Company (Botswana), (RIPCO(B))	Semi-Government	281 (93 in Technical Department)	1974	Research and Development
4	National Food Technology Research Centre (NFTRC)	Semi-Government	57 (30 technical cadre)	1984	Research and Development
5	Botswana Technology Centre, (BOTECH)	Semi-Government	.	1979	Research and Development
6	Botswana Institute for Development Policy Analysis, (BIDPA)	Semi-Government	34 (19 Researchers)	1995	Research and Development
7	Botswana Vaccine Institute, (BVI)	Semi-Government	.	1977	Research and Development
8	Department of Agricultural Research, (DAR).	Semi-Government	252 (58 Professionals)	1969	Research and Development
9	Veld Products	Non-Governmental	20 but Variable (up-to 7 professionals)	1981	Extension
10	Thusano Lefatsheng	Non-Governmental	.	1984	Extension
11	Permaculture Botswana	Non-Governmental	.	1989	Extension
Total	N	11	6	11	11

Appendix 2: Covering Letter to Introduce the Researcher to Prospective Interviewees

Wolfson School of Mechanical and Manufacturing Engineering
Loughborough University Leicestershire LE11 3TU UK
Switchboard: +44 (0)1509 263171



To Whom It May Concern

I am Mr. Keaboka Sethebe, a 2nd Year PhD (Mechanical Engineering) research student at Loughborough University, United Kingdom. I am conducting a study to find out the different product design methods used by organizations both in Botswana and the United Kingdom. You are being invited to participate in the research which is funded by the Ministry of Communications, Science and Technology in Botswana. As part of this programme I need descriptions of the product design process as practised in companies and Research, Science and Technology Institutions in both Botswana and the United Kingdom.

I am requesting an outline description of the design process, or processes, normally used in your organisation. This would ideally be in the form of a flow chart showing the major stages of a design project together with a worded description, but may be in any format if another is more convenient. A very detailed description of the process is not required, it is envisaged that something suitable could be prepared in approximately 15 minutes. I might wish to contact you by telephone after receiving the flow chart if further clarification might be useful. An interview as such is not necessary. If you do not wish to receive a telephone call please indicate this with your description of the design process.

It would be helpful if the process descriptions could reach me by 31st August 2009. My e-mail address is K.M.Sethebe@lboro.ac.uk and the postal address is as above.

If you would like more information about my research please contact me. I would like to emphasize that I am not selling anything, this is purely research and you will not receive any other follow-ups from this work. I am working to the Loughborough University Code of Ethics, which means we cannot identify you or inform anybody outside of information you supply. These could be viewed at <http://www.lboro.ac.uk/admin/committees/ethical/gn/dcas.htm> and must comply with the Data Protection Act of 1998 which may be viewed at <http://www.lboro.ac.uk/admin/ar/policy/dpact/index.htm>. Your views will be reported mixed-in with others.

Your assistance is deeply appreciated.

Sincerely,

A handwritten signature in black ink, appearing to read 'Keaboka Sethebe', with a stylized flourish at the end.

Keaboka Sethebe

PhD Research Student



Appendix 3: Questionnaire used in Pilot Structured Interviews

1.0 Respondent Details (to establish organisational parameters for later use in classification)																
1.1 Mr/Mrs/Miss/Ms/Other	<input type="text"/>															
1.2 First Name	<input type="text"/>															
1.3 Surname	<input type="text"/>															
1.4 Company Position	<input type="text"/>															
1.5 Company Name	<input type="text"/>															
1.6 Address Line 1 (Town)	<input type="text"/>															
1.7 Address Line 2 (Post Code)	<input type="text"/>															
1.8 Address Line 3 (Country)	<input type="text"/>															
1.9 What is your customer base?	<table border="0"> <tr> <td><input type="checkbox"/></td> <td>1 - 999</td> <td></td> </tr> <tr> <td><input type="checkbox"/></td> <td>1000 - 9999</td> <td></td> </tr> <tr> <td><input type="checkbox"/></td> <td>More than 10 000</td> <td>_____ (Please print in the number)</td> </tr> </table>	<input type="checkbox"/>	1 - 999		<input type="checkbox"/>	1000 - 9999		<input type="checkbox"/>	More than 10 000	_____ (Please print in the number)						
<input type="checkbox"/>	1 - 999															
<input type="checkbox"/>	1000 - 9999															
<input type="checkbox"/>	More than 10 000	_____ (Please print in the number)														
1.10 How many employees work in your organisation?	<table border="0"> <tr> <td><input type="checkbox"/></td> <td>1 - 49</td> <td></td> </tr> <tr> <td><input type="checkbox"/></td> <td>50 - 199</td> <td></td> </tr> <tr> <td><input type="checkbox"/></td> <td>200 - 299</td> <td></td> </tr> <tr> <td><input type="checkbox"/></td> <td>300 - 499</td> <td></td> </tr> <tr> <td><input type="checkbox"/></td> <td>More than 500</td> <td>_____ (Please print in the number)</td> </tr> </table>	<input type="checkbox"/>	1 - 49		<input type="checkbox"/>	50 - 199		<input type="checkbox"/>	200 - 299		<input type="checkbox"/>	300 - 499		<input type="checkbox"/>	More than 500	_____ (Please print in the number)
<input type="checkbox"/>	1 - 49															
<input type="checkbox"/>	50 - 199															
<input type="checkbox"/>	200 - 299															
<input type="checkbox"/>	300 - 499															
<input type="checkbox"/>	More than 500	_____ (Please print in the number)														
1.11 What is the approximate number of designers in your organisation?	<table border="0"> <tr> <td><input type="checkbox"/></td> <td>1 - 49</td> <td>_____ (Please print in the number of students)</td> </tr> <tr> <td><input type="checkbox"/></td> <td>50 - 199</td> <td></td> </tr> <tr> <td><input type="checkbox"/></td> <td>200 - 299</td> <td>_____ (Please print in the number of staff)</td> </tr> <tr> <td><input type="checkbox"/></td> <td>300 - 499</td> <td></td> </tr> <tr> <td><input type="checkbox"/></td> <td>More than 500</td> <td>_____ (Please print in the number)</td> </tr> </table>	<input type="checkbox"/>	1 - 49	_____ (Please print in the number of students)	<input type="checkbox"/>	50 - 199		<input type="checkbox"/>	200 - 299	_____ (Please print in the number of staff)	<input type="checkbox"/>	300 - 499		<input type="checkbox"/>	More than 500	_____ (Please print in the number)
<input type="checkbox"/>	1 - 49	_____ (Please print in the number of students)														
<input type="checkbox"/>	50 - 199															
<input type="checkbox"/>	200 - 299	_____ (Please print in the number of staff)														
<input type="checkbox"/>	300 - 499															
<input type="checkbox"/>	More than 500	_____ (Please print in the number)														
1.12 What is the approximate turnover of the organisation?	<table border="0"> <tr> <td><input type="checkbox"/></td> <td>less than £49 999 (P499 999)</td> <td></td> </tr> <tr> <td><input type="checkbox"/></td> <td>£50 000 to £99 999 (P500 000 to P999 999)</td> <td></td> </tr> <tr> <td><input type="checkbox"/></td> <td>More than £100 000 (P1 000 000)</td> <td>_____ (Please print in the number)</td> </tr> </table>	<input type="checkbox"/>	less than £49 999 (P499 999)		<input type="checkbox"/>	£50 000 to £99 999 (P500 000 to P999 999)		<input type="checkbox"/>	More than £100 000 (P1 000 000)	_____ (Please print in the number)						
<input type="checkbox"/>	less than £49 999 (P499 999)															
<input type="checkbox"/>	£50 000 to £99 999 (P500 000 to P999 999)															
<input type="checkbox"/>	More than £100 000 (P1 000 000)	_____ (Please print in the number)														

Continues Next Page . . .

Appendix 3: Questionnaire used in Pilot Structured Interviews (Cont...)

2.0 Current Design Methods (to establish a preferred or recommended methods)

2.1 Give a description of the methods that you teach check for demonstrable evidence for requirements in usability *reliability, maintainability, affordability and supportability*

Requirement Analysis: sequence

Functional Analysis:

Requirements Allocation:

Trade-Off studies:

Synthesis:

Evaluation:

Specifications:

(Please use the back of the page if necessary, especially for diagrams)

2.2 Why do you choose that method?

2.3 Which part of the method(s) is (are) easy to use?

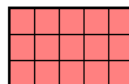

Simple
Medium
High

Put the method number(s) dependig on the required research intensiveness and give reasons on a separate sheet

2.4 Are ther any other methods, perhaps being taught by others?

Continues Next Page . . .

Appendix 3: Questionnaire used in Pilot Structured Interviews (Cont...)

3.0 Design Method Tools

3.1 Are there any meetings that affect/discuss design activity in your organisation?

(Please describe briefly, including members of the especially chairman and secretary)

Name of Meeting	Required Reports	Name of Meeting	Required Reports
_____	_____	_____	_____
_____	_____	_____	_____
_____	_____	_____	_____
_____	_____	_____	_____
_____	_____	_____	_____
_____	_____	_____	_____
_____	_____	_____	_____
_____	_____	_____	_____
_____	_____	_____	_____
_____	_____	_____	_____

(Please use the back of the page if necessary, especially for diagrams)

3.2 Which of the following records (copies) are you willing to release for analysis?

(Please put a 'X' on the appropriate box)

<input type="checkbox"/>	Syllabus and Lecture notes <i>(if providing training, on the job or otherwise)</i>
<input type="checkbox"/>	Plans and Reports on Planning
<input type="checkbox"/>	Minutes and Material for Discussion on Issues related to Design

3.3 Which working codes you use?

<input type="checkbox"/>	In-House	_____
<input type="checkbox"/>	(Inter)national	_____

Please specify all the standards and give reasons for choosing them overleaf

3.4 What prompts improvements to your methods?

<input type="checkbox"/>	Changes in Mission, Vision or Values	How many times	<input type="checkbox"/>	1 - 3
<input type="checkbox"/>	Improvements in other Process		<input type="checkbox"/>	4 - 6
<input type="checkbox"/>	Users		<input type="checkbox"/>	7 - 10

Please put a 'X' where appropriate

3.5 Is your organisation accredited to any Body?

Please specify all appropriate Accreditation Bodies and give reasons overleaf

Continues Next Page . . .

Appendix 3: Questionnaire used in Pilot Structured Interviews(Cont...)

4.0 Company Products

4.1 How does your deal with categorise of products? Variant Design

Depending on the required research intensiveness and give examples if you have been involved with any of them

Adaptive Design

Original Design

4.3 How fast can your method deal with developing products fast?

4.4 How does your method address the concerns for manufacturing, maintenance and support?

5.0 Declaration

5.1 Invitation Letter

An invitation letter from Loughborough University is sent by post, fax or e-mail to your company to prompt you to answer the questionnaire and the letter will also contain pertinent information related to the study.

5.2 Consent

Information regarding plans and reports e.t.c. will be retain for the purpose of analysis by the researcher only.

5.3 Confidentiality

Anonymity of your company will be preserved in the presentation of the study results. Information about yur company will not be given to any company.

5.4 Keeping you Informed

Your company will be given a report of the survey findings and specific analysis pertaining to your company can be given upon written request to Loughborough University in the address given below

Appendix 4: Final Version Questionnaire (Cont...)

2.0 Products	
2.1 How do you categorize your products (Please put an 'X' on all appropriate boxes)	<input type="checkbox"/> Variation or Modifications to Existing Products <input type="checkbox"/> Adaptations or Adoptions of Existing Products <input type="checkbox"/> Invention of New Products <input type="checkbox"/> Extension Services <input type="checkbox"/> Other _____ (Please Specify)
2.2 Where do you market your products (Please put an 'X' on all appropriate boxes)	<input type="checkbox"/> Worldwide <input type="checkbox"/> European Economic Area (EEA) <input type="checkbox"/> North American Free Trade Area (NAFTA) <input type="checkbox"/> Union of South American Nations (UNASUR) <input type="checkbox"/> Association of South Eastern Nations (ASEAN) <input type="checkbox"/> South Asian Association for Regional Cooperation (SAARC) <input type="checkbox"/> Caribbean Community (CAICOM) <input type="checkbox"/> African Economic Community incl. SADC, COMESA, ECOWAS <input type="checkbox"/> Other _____ (Please Specify)
2.3 Which performance metric best defines your product e.g. Energy, Extraction Rate, Information Processing, Power, e.t.c (Please Specify)	_____ _____
2.4 What is your companies approximate average investment in new products or product improvements per annum? (Please Specify to the nearest US\$ 000 000)	_____ in Figures _____ in Words _____
2.5 How fast must you come with newly developed products annually? (Please put an 'X' on the appropriate box)	<input type="checkbox"/> 1 - 3 <input type="checkbox"/> 4 - 6 <input type="checkbox"/> 7 - 10 <input type="checkbox"/> Other _____ (Please Specify)
2.6 How do you augment your product? (Please put an 'X' on all appropriate boxes)	<input type="checkbox"/> Delivery _____ (Please Specify Period in months) <input type="checkbox"/> Warranty _____ (Please Specify Period in months) <input type="checkbox"/> Maintenance Serve <input type="checkbox"/> Installation <input type="checkbox"/> Training <input type="checkbox"/> Other _____ (Please Specify)

Continues Next Page . . .

Appendix 4: Final Version Questionnaire (Cont...)

3.0 Methods	
3.1 Fill in a description of the design method followed in your company (including responsible committees, engineers, e.t.c)	
<input type="text"/>	<input type="text"/>
<input type="text"/>	<input type="text"/>
<input type="text"/>	<input type="text"/>
<input type="text"/>	<input type="text"/>
3.2 How does your company organise for product development and how do you perceive its success on a scale of 1 - Poor, 5 - Good? (Put an 'X' on the appropriate box)	
<input type="checkbox"/>	Functional Teams <input type="checkbox"/> 1 <input type="checkbox"/> 3 <input type="checkbox"/> 5
<input type="checkbox"/>	Matrix Teams
<input type="checkbox"/>	Project Teams
<input type="checkbox"/>	Other _____ (Please Specify)
3.3 What is your companies positioning strategy? (Put an 'X' on the appropriate box)	
<input type="checkbox"/>	Process Focus
<input type="checkbox"/>	Product Focus
<input type="checkbox"/>	Intemediate Focus
3.4 Which working codes do you use? (Please Specify all Standard Codes)	
<input type="checkbox"/>	In - House
<input type="checkbox"/>	(Inter)national
4.0 Declaration	
4.1 Invitation Letter	An invitation letter from Loughborough University is sent by post, fax or e-mail to your company to prompt you to answer the questionnaire and the letter will also contain pertinent information related to the study.
4.2 Consent	Information regarding plans and reports e.t.c. Will be retained for the purposes of analysis by the researcher only
4.3 Confidentiality	Anynomity of your company will be preserved in the presentation of the study results. Information about your company will not be given to any company.
4.4 Keeping you Informed	Your company will be given a report of the survey findings and specific analysis pertaining to your company can be written upon written request to Loughborough University in the address given below.
4.5 Address	Loughborough University Research Student Office Academic Registry Leicestershire LE11 3TU United Kingdom Tel: +44 (0) 1509 263171 Fax: +44 (0) 1509 223938 e-mail: PGResearch@lboro.ac.uk

Appendix 5: The UK Interview Respondents for Pilot and Final Structured Interviews

Pilot Structured Interview Respondents

1. Mr. Paul King
Wolfson School of Mechanical and Manufacturing
Head of Postgraduate Studies and Formula Student Coordinator
Senior Lecturer
Loughborough University
2. Dr. Bob Young
Wolfson School of Mechanical and Manufacturing
Programme Director, PDMr
Senior Lecturer
Loughborough University
3. Dr. Peter Willmot
Wolfson School of Mechanical and Manufacturing
Head of Undergraduate Studies
Programme Director, EST / Mech Eng and Mech Eng Part A Tutor
Loughborough University
4. Dr. Philip Fletcher
Wolfson School of Mechanical and Manufacturing
Part time University Lecturer

Final Structured Interview Respondents

1. Prof. Simon Austin
Civil and Building Engineering
Professor of Structural Engineering
Loughborough University
2. Mr. Ross Weir
Progressive Sports Ltd
Sports Technology
Director

Appendix 6: The Botswana Interview Respondents for the Final Structured Interviews and the Participants in Kanon Model Activities

Final Structured Interview Respondents

1. Mr. Segwati Pelotona
Business, Marketing and Extensions Department
Chief Engineer – Technology Transfer
Rural Industries Promotions Company (Botswana)
2. Dr. Edward Dintwa
Department of Food Technology
Process Engineer
National Food Technology Research Centre
3. Mr. James Molemga
Renewable Energy
Acting Principal Engineer
Botswana Technology Centre Centre
4. Mr. Shadrack Situmbeko
Department of Industrial Design and Technology
Lecturer
University of Botswana

Participants in the Kolb's Model

1. Mrs. Kepotlake Kolane
Project Development Section
Product Design Office
Engineer – Design
Rural Industries Promotions Company (Botswana)
2. Mr. Joshua Ntwa
Energy Section
Electrical and Electronics Engineer
Rural Industries Promotions Company (Botswana)
3. Mr. Sebetso Tsie
Project Development Section
Product Design Office
Engineer – Design
Rural Industries Promotions Company (Botswana)

4. Mr. Batumile Matake
Project Development Section
Product Design Office
Engineer – Design
Rural Industries Promotions Company (Botswana)

Appendix 7: The Application of the PDG to the Design of the Planter – A Short Presentation

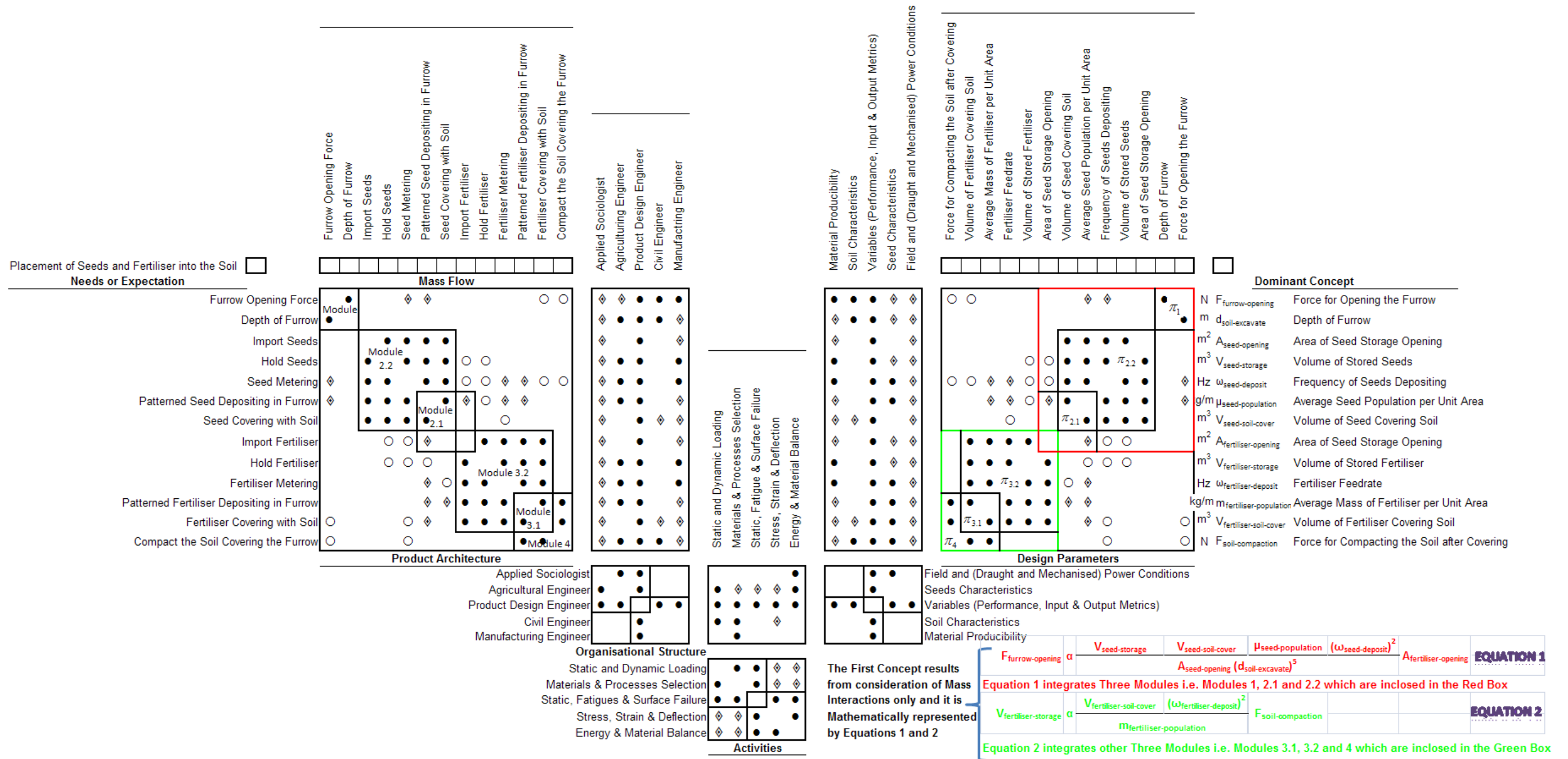

The illustration shows a selected few techniques from the PDG and concentrates on the product design drivers only. The headings are identical to those that were used during the formative stages of the PDG. The above analysis illustrates focuses on mass flow only; separate analysis must be made for energy flow, geometric (or spatial) Requirements, Signal Flow and a combination of all these in order to select the dominant for product realisation

Appendix 7: The Application of the PDG to the Design of the Planter – A Short Presentation (Cont ...)

The following is a dimensional analysis to derive Equations 1 and 2.

For Dimensional Consistency π_1 , $\pi_{2,1}$ and $\pi_{2,2}$ are treated together (They are Dimensionally Inconsistent on their Own; hence, their Incapability to Generate any Product Concept)

Dimensions	Metrics	Variables	Descriptions
[MLT ⁻²]	N	$F_{\text{furrow-opening}}$	Force for Opening the Furrow
[L]	m	$d_{\text{soil-excavate}}$	Depth of Furrow
[L ²]	m ²	$A_{\text{seed-opening}}$	Area of Seed Storage Opening
[L ³]	m ³	$V_{\text{seed-storage}}$	Volume of Stored Seeds
[T ⁻¹]	Hz	$\omega_{\text{seed-deposit}}$	Frequency of Seeds Depositing
[ML ⁻²]	kg/m ²	$\mu_{\text{seed-population}}$	Average Seed Population per Unit Area
[L ³]	m ³	$V_{\text{seed-soil-cover}}$	Volume of Seed Covering Soil
[L ²]	m ²	$A_{\text{fertiliser-opening}}$	Area of Fertiliser Storage Opening

Dimensions	Recurring Variables
[MLT ⁻²]	$F_{\text{furrow-opening}}$
[L]	$d_{\text{soil-excavate}}$
[T ⁻¹]	$\omega_{\text{seed-deposit}}$
Number of Variables: 8	
Number of Fundamental Units: 3 [M],[L] and [T]	
Number of Dimensionless Groups: 5	

$$\pi_a = \frac{A_{\text{seed-opening}}}{(d_{\text{soil-excavate}})^2}$$

$$\pi_b = \frac{V_{\text{seed-storage}}}{(d_{\text{soil-excavate}})^3}$$

$$\pi_c = \frac{\mu_{\text{seed-population}} d_{\text{soil-excavate}} (\omega_{\text{seed-deposit}})^2}{F_{\text{furrow-opening}}}$$

$$\pi_d = \frac{V_{\text{seed-soil-cover}}}{(d_{\text{soil-excavate}})^3}$$

$$\pi_e = \frac{A_{\text{fertiliser-opening}}}{(d_{\text{soil-excavate}})^2}$$

$$\pi_a \propto (\pi_b, \pi_c, \pi_d, \pi_e)$$

$$\frac{A_{\text{seed-opening}}}{(d_{\text{soil-excavate}})^2} \propto \frac{V_{\text{seed-storage}}}{(d_{\text{soil-excavate}})^3} \frac{\mu_{\text{seed-population}} d_{\text{soil-excavate}} (\omega_{\text{seed-deposit}})^2}{F_{\text{furrow-opening}}} \frac{V_{\text{seed-soil-cover}}}{(d_{\text{soil-excavate}})^3} \frac{A_{\text{fertiliser-opening}}}{(d_{\text{soil-excavate}})^2}$$

$$F_{\text{furrow-opening}} \propto \frac{V_{\text{seed-storage}} V_{\text{seed-soil-cover}} \mu_{\text{seed-population}} (\omega_{\text{seed-deposit}})^2}{A_{\text{seed-opening}} (d_{\text{soil-excavate}})^3} A_{\text{fertiliser-opening}} \quad \text{EQUATION 1}$$

For Dimensional Consistency $\pi_{3,1}$, $\pi_{3,2}$ and π_4 are treated together (They are Dimensionally Inconsistent on their Own; hence, their Incapability to Generate any Product Concept)

Dimensions	Metrics	Variables	Descriptions
[L ²]	m ²	$A_{\text{fertiliser-opening}}$	Area of Seed Storage Opening
[L ³]	m ³	$V_{\text{fertiliser-storage}}$	Volume of Stored Fertiliser
[T ⁻¹]	Hz	$\omega_{\text{fertiliser-deposit}}$	Fertiliser Feedrate
[ML ⁻²]	kg/m ²	$m_{\text{fertiliser-population}}$	Average Mass of Fertiliser per Unit Area
[L ³]	m ³	$V_{\text{fertiliser-soil-cover}}$	Volume of Fertiliser Covering Soil
[MLT ⁻²]	N	$F_{\text{soil-compaction}}$	Force for Compacting the Soil after Covering

Dimensions	Recurring Variables
[L ²]	$A_{\text{fertiliser-opening}}$
[T ⁻¹]	$\omega_{\text{fertiliser-deposit}}$
[ML ⁻²]	$m_{\text{fertiliser-population}}$
Number of Variables: 6	
Number of Fundamental Units: 3 [M],[L] and [T]	
Number of Dimensionless Groups: 3	

$$\pi_f = \frac{(V_{\text{fertiliser-storage}})^2}{(A_{\text{fertiliser-opening}})^3}$$

$$\pi_g = \frac{(V_{\text{fertiliser-soil-cover}})^2}{(A_{\text{fertiliser-opening}})^3}$$

$$\pi_h = \frac{F_{\text{soil-compaction}} (\omega_{\text{fertiliser-deposit}})^4}{(m_{\text{fertiliser-population}})^2}$$

$$\pi_f \propto (\pi_g, \pi_h)$$

$$\frac{(V_{\text{fertiliser-storage}})^2}{(A_{\text{fertiliser-opening}})^3} \propto \frac{(V_{\text{fertiliser-soil-cover}})^2}{(A_{\text{fertiliser-opening}})^3} \frac{F_{\text{soil-compaction}} (\omega_{\text{fertiliser-deposit}})^4}{(m_{\text{fertiliser-population}})^2}$$

$$V_{\text{fertiliser-storage}} \propto \frac{V_{\text{fertiliser-soil-cover}} (\omega_{\text{fertiliser-deposit}})^2}{m_{\text{fertiliser-population}}} F_{\text{soil-compaction}} \quad \text{EQUATION 2}$$

Appendix 7: The Application of the PDG to the Design of the Planter – A Short Presentation (Cont ...)

Below is a presentation of the optimisation results using data from a previously tested planter from RIPCO (B).

$$\pi_8 \alpha (\pi_1, \pi_2, \pi_3, \pi_4, \pi_5, \pi_6, \pi_7, \pi_9, \pi_{10})$$

$$m_{\text{fertiliser-population}} \propto \frac{A_{\text{seed-opening}} V_{\text{seed-storage}} V_{\text{seed-soil-cover}} A_{\text{fertiliser-opening}} V_{\text{fertiliser-storage}} V_{\text{fertiliser-soil-cover}} \omega_{\text{fertiliser-deposit}} F_{\text{soil-compaction}}}{F_{\text{furrow-opening}} (d_{\text{soil-excavate}})^{14} \omega_{\text{seed-deposit}}} \mu_{\text{seed-population}}$$

Constants	Sorghum	Maize	Cowpea	Groundnuts	Sunflower	Units
$A_{\text{seed-opening}}$	0.0176	0.0176	0.0176	0.0176	0.0176	m ²
$A_{\text{fertiliser-opening}}$	0.0176	0.0176	0.0176	0.0176	0.0176	m ²
$F_{\text{furrow-opening}}$	53.193	53.19296703	53.19296703	53.19296703	53.19296703	N
Design Variables						
$V_{\text{fertiliser-storage}}$	0.00519	0.00519	0.00519	0.00519	0.00519	m ³
$V_{\text{seed-storage}}$	0.00260	0.00260	0.00260	0.00260	0.00260	m ³
$V_{\text{seed-soil-cover}}$	0.00176	0.00176	0.00176	0.00176	0.00176	m ³
$V_{\text{fertiliser-soil-cover}}$	0.00176	0.00176	0.00176	0.00176	0.00176	m ³
$\omega_{\text{fertiliser-deposit}}$	0.208	0.347	0.139	0.139	0.0347	Hz
$\omega_{\text{seed-deposit}}$	0.104	0.174	0.069	0.069	0.0347	Hz
$F_{\text{soil-compaction}}$	1324	1324	1324	1324	1324	N
Performance Variables						
$m_{\text{fertiliser-population}}$	32.083	32.083	44.916	64.166	0.000	kg/m ² (To be Calibration from Experiments)
Constraints						
$d_{\text{soil-excavate}} \geq$	0.1	0.1	0.1	0.1	0.1	m
$\mu_{\text{seed-population}} \leq$	5	5	7	10		kg/m ²

(Source: Validation Report - Modular Type and Double Row Tractor Drawn Planter, RIPCO(B) Quality Office)

Required Plant-Food Constituents per kg of Fertiliser

Nitrogen	N	38%	56%
Phosphorus	P	18%	22%
Potassium	K	43%	22%

Objective:

Maximise the $\mu_{\text{seed-population}}$ and $m_{\text{fertiliser-population}}$ in 1 m² of Soil Area

or

$$m_{\text{fertiliser-population}} = \frac{A_{\text{seed-opening}} V_{\text{seed-storage}} V_{\text{seed-soil-cover}} A_{\text{fertiliser-opening}} V_{\text{fertiliser-storage}} V_{\text{fertiliser-soil-cover}} \omega_{\text{fertiliser-deposit}} F_{\text{soil-compaction}}}{F_{\text{furrow-opening}} (d_{\text{soil-excavate}})^{14} \omega_{\text{seed-deposit}}} \mu_{\text{seed-population}}$$

Subject to:

$$\mu_{\text{seed-population}} \leq 5$$

$$m_{\text{fertiliser-population}} \leq 32.083$$

	Design Variables	Objective Function		Constraints	
		$\mu_{\text{seed-population}}$	$m_{\text{fertiliser-population}}$	$\mu_{\text{seed-population}}$	$m_{\text{fertiliser-population}}$
		kg/m ²	kg/m ²	kg/m ²	kg/m ²
	1		6.417	5	32.083
	2		12.833	5	32.083
	3		19.250	5	32.083
	4		25.666	5	32.083
Sorghum & Maize	5		32.083	5	32.083
	6		38.499	5	32.083
Cowpea	7		44.916	5	32.083
	8		51.332	5	32.083
	9		57.749	5	32.083
Groundnuts	10		64.166	5	32.083
	11		70.582	5	32.083

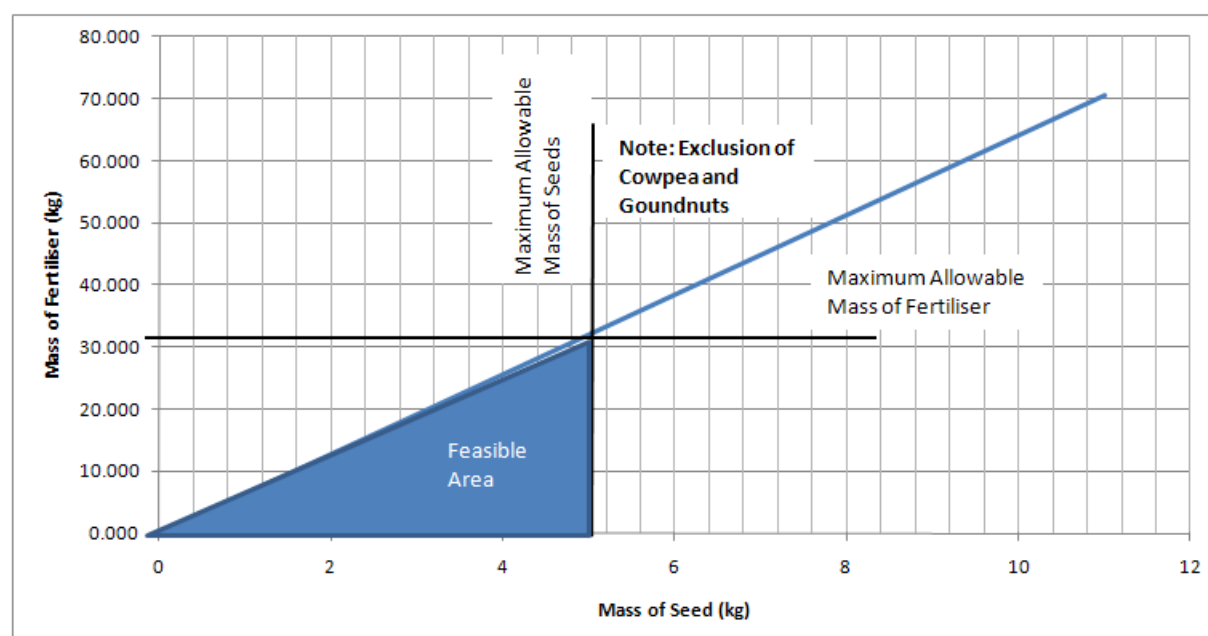

Appendix 8: Job Description - Grain/Food Production and Processing Programmes

Job Title: Morama Processing Team	Job Category: Project Management	Location: Kanye
Department:	Job Code: Product Design	Position Type: Contract & Part-Time
Responsible to:	Responsible for: Crop Protection Environmental Assessment Food Research	Food Process Design Product Technology Development Technology Transfer
Job Purpose: Accomplishes Project Objectives by Planning and Evaluating Project Activities		
Duties:	<ol style="list-style-type: none"> 1. Accomplish Human Resource Objectives Recruitment, Training and Coaching Resource Scheduling, Appraising and Job Expectation Communication Policies and Procedures Enforcement 2. Achieve Operational Objectives Contribution to, and Reviewing of, Strategic Plans Preparing and Completing Action Plans Implementing and Auditing Customer-Service Standards; Identifying Trends 3. Meet Financial Objectives Earned Value Management and Budget 	Skills/Qualifications: Project Management Process Improvement Performance Management
Approved by: Date:	Last Updated by: Date:	Date of Next Review:

Job Description

Appendix 9: Paper to be Presented at the 12 Biennial Conference of the Botswana Institute of Engineers, 2011

From Botswana Brand to the *Kgotla* Economy: Using Botswana’s Cultural Heritage to inspire Innovative Product Design Activities

Keaboka Motona Sethebe, Andrew John Taylor and Prof. Weeratunga Malalasekera

Synopsis:

The work described provides the development, implementation and evaluation of engineering product design guidelines suitable for designers in the least economically developed countries (LDC). The motivation arises from efforts that continue to be made by the LDC and international agencies towards the development of technology transfer mechanisms. It is argued here that the product design guidelines which are derived from existing and successful product design methods provide more capacity for devising intermediate technologies than the product design methods that are in current use by research, science, technology and innovation institutions (RSTI) located within the LDC.

A specific focus is placed on the policy implementation efforts of Botswana that are geared towards establishing a culture of productivity; a proposal is made to place engineering product design activity on the agenda as a means of achieving industrial development and economic transformation. This paper looks at the development of intermediate technologies by downscaling productive and automated technologies of the most economically developed countries (MDC) and demonstrates one way by which appropriate technology that is indigenous to the LDC can be upgraded. Two aspects of the North – South International Technology Transfer are dealt with: the development of the cereal milling technology by a partnership between Canada, an MDC, assisted Botswana and other LDC. This study, which has resulted in the proposal of product design guidelines, is conducted through training in the United Kingdom, an MDC, as part of a pilot project initiated by the Ministry of Infrastructure, Science and Technology in Botswana through the Department of Research, Science and Technology (DRST) and Rural Industries Promotions Company (Botswana) [RIPCO (B)].

Key Words: Botswana Brand, Vision 2016, *Kgotla* Economy, Appropriate Technology, Intermediate Technology, Product Design.

1. Introduction

Schumacher [1] established the expression “Intermediate Technology” (ITech) to describe a new technology suitable for the least economically developed countries (LDC) that may represent economic growth on a continuum from the “Appropriate Technology” (ATech; Table 54) that is indigenous to the LDC to productive and automated technology of the most economically developed countries (MDC). In certain circumstances, ITech is also preferred by the MDC.

Appropriate Technology (ATech)	Intermediate Technology (ITech)
Provides questionable solution i.e. the solution has potential to cause additional problems more especially within a network solutions.	Engages the whole problem i.e. the solution is complete and is viewed as a potential within other possible solutions.
Bear no relationship to the market leading technology and have no timing or forecasting for its introduction.	Result from a purposeful strategy to lag behind technology developed by market leaders to affect the timing of innovation adoption and impose lower adoption cost to customers.

Table 54: Summarised Differences between Appropriate Technology and Intermediate Technology

The Vision 2016 Taskforce [2] have observed that Botswana:

“has set itself a low benchmark by comparing itself with poor countries, rather than with the best in the world.”

Thus the question of devising or adopting appropriate technologies does not match the economic success of Botswana; then, a question that arises is how to benchmark “the best in the world”?

Also still needed is a culture of productivity to promote a visible, coherent and adaptable work structure that integrates all activities of organisational teams to tackle national problems and the development of detailed

descriptions of how employees should organise their experience to achieve productive accomplishments within particular settings [3]; such a culture of productivity that is developed by organisational teams may be established to find solutions to the problems that are more prevalent in the LDC.

Through co-ordinated participation of design teams in organisations, structured product design activities can open opportunities to expand the markets of the LDC as well as economic transformation and diversification that results from an increased number of tradable commodities. In this regard, product design activities aimed at the development of intermediate technologies may be a vehicle towards the quick achievements of national priorities set out by the policy making structures of the LDC; a case in point is Botswana Vision 2016.

2. Culture and Competitive Enterprising between Districts

Product design requires technology deployment [4]. In the case of the LDC, such as Botswana, ITech is being advocated according to Whitby [5] who categorised the basic needs of the LDC as follows (Table 55):

1. Water and Sanitation	2. Employment	3. Energy
c. Water Collection d. Water Conservation a. Water Supply	b. Small Scale Industry c. Income Generation Activities	c. Cooking d. Warmth d. Lighting
4. Food Nutrition and Health	5. Building and Construction	6. Transport
c. Food Production d. Food Processing a. Food Storage	c. Low Cost Housing d. Building Materials e.g. Clay and Paint	d. Animal Drawn Carts e. Bicycle f. Road

Table 55: Categories of Basic Needs of the Least Economically Developed Countries (Source: Adapted from Whitby, 1985)

Product design can establish, maintain and expand both national and international markets for the LDC by contributing towards industrial development; this entails initially addressing the needs of a single country followed by the establishment of a sphere of influence that may increase to regional and continental markets.

The work of the International Development Research Centre (IDRC), which is based in Canada, provides an example that may be cited on the approaches that have been successfully used to address the food nutrition and health basic needs of the LDC. The IDRC recognized the efforts of African policy makers to encourage the production and processing of drought resistant crops and sought to assist in the development of intermediate technologies, [6]. The aim was not to come up with ‘one solution fits all’ but to evolve the food processing intermediate technology through co-ordinated research for development (R4D) activities performed on a visible operational structure that includes possible re-designs, as well as occasional freezing of changes to the associated products, to address the nuances of the basic needs in different countries. As cited by Bassey and Schimidt [6], Reichert and Youngs [7-8] state that the evolution of the abrasive-disk dehullers was started by the Prairie Regional Laboratory (PRL, now the Plant Biotechnology Institute, PBI) which operates as part of the National Research Council of Canada (NRCC). In 1974, PRL modified a barley thresher, used by farmers in Canada, into an effective dehuller prototype for use in Nigeria as a sub-system of a food processing plant consisting of the dehuller, hammermill and a diesel engine as a prime mover. The PRL food processing plant was used also in Ghana and Senegal; a mini-PRL dehuller was developed and used in Ethiopia, Gambia, Sudan and Zimbabwe.

Whilst focusing on the success of the sorghum dehuller design in Botswana, Schmidt [9] explains the R4D process that was applied to support the Rural Industries Innovation Centre (RIIC) and Botswana Agricultural Marketing Board (BAMB) – this gave birth to the renowned RIPCO (B) milling package which is structurally similar to the PRL food processing plant. RIIC is a subsidiary of the Rural Industries Promotions Company (Botswana) [RIPCO (B)] which is a research, science, technology and innovation institution (RSTI) whilst BAMB is a grain storage agency of the Botswana Government. Organisations that are specifically established to innovatively exploit advances in applied science to provide entrepreneurial technologies may be referred to as research, science, technology and innovation institutions (RSTI). RIPCO (B) was established in 1974 and was supported from 1974 - 1984 by Friedrich Ebert Stiftung Foundation (FES), from Germany, in partnership with the Botswana Government [10]. The mandate of RIPCO (B) was to:

“advise, assist and build up rural light industry by disseminating appropriate technologies on a commercial basis. The aim was to help the people in Botswana’s rural regions who have remained poor in spite of the economic miracle because rapid growth has not alleviated social inequalities”

RIIC modified the PRL dehuller to suit the conditions of Botswana that were identified by Hamilton [11]. The PRL/RIIC sorghum dehuller was then diffused from Botswana to ten other African countries, namely: Lesotho, Malawi, Mali, Namibia, Senegal, South Africa, Swaziland, Tanzania, Zambia and Zimbabwe [12]. According to Rohrbach et. al. [13], the sorghum dehuller is currently contracted for other countries such as South Africa and Zimbabwe although RIIC remains as the main supplier in Botswana. This demonstrates the increase in the geographical coverage to penetrate the Southern African Customs Union (SACU), Southern African Development Community (SADC) and Economic Community of West African States (ECOWAS) markets (Figure 112). The success rate of establishing cereal mills differs in the different countries because of the following factors which hinge on a culture of productivity:

1. The relative strength of consumer demand for sorghum flour;
2. The cereal milling technology for was readily available;
3. The magnitude of government financial support for development of the industry;
4. The reduction of import barriers for grain; and
5. The reliable and readily available quality grain necessary to operate throughout the year.

A semi-automated sorghum mill with an output of 2500 kg/hr had been installed by RIIC in Botswana and the diversity of products have increased to include food fortification through a double ribbon reversible mixer designed in 2004 in collaboration with the National Food Technology Research Centre (NFTRC); both RIIC and NFTRC are conducting research to introduce the milling of legumes – a fact that would require another re-design that ensures and re-enforces the drive for economic diversification.

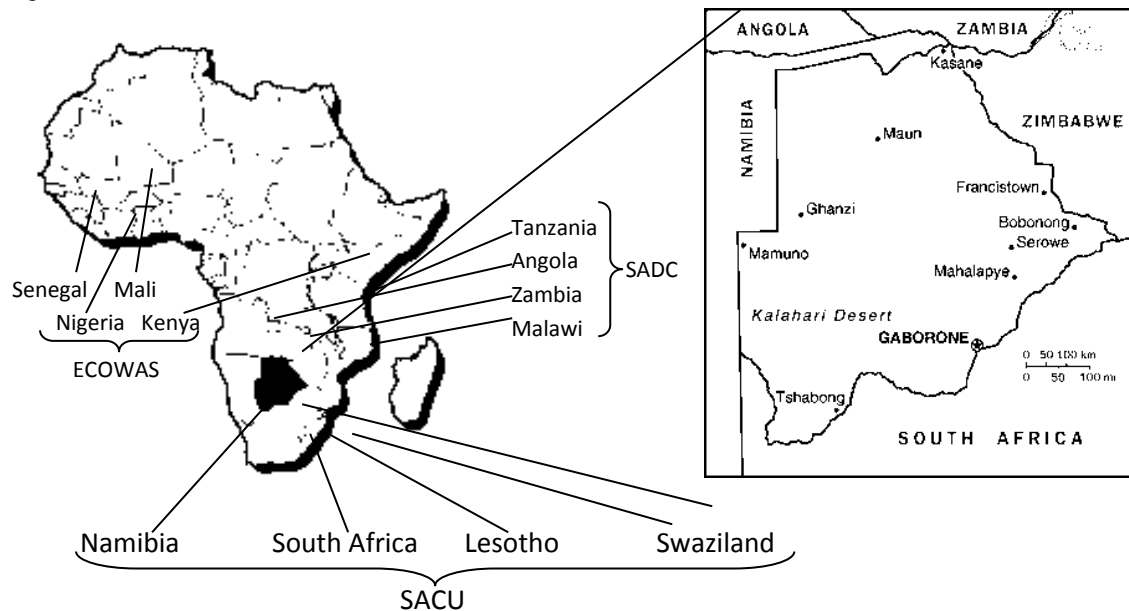

Figure 112: Location of Botswana relative to SACU, SADC and ECOWAS Member Countries where the Dehuller was diffused

Rosenberg [14] coined the idea of "technological expectations" which is well recognized by those examining the diffusion of innovation. Livingstone [15] summarised that, the "technological expectations" of LDC revolve around the interest for the development of small, micro and medium scale enterprises (SMME) particularly in rural industries because of:

1. Aspirations for localisation and local control of industry;
2. Emphasis on rural development;
3. A search for more labour intensive "appropriate technology" and its improvement coupled with a concern for growth of employment associated with import substitution by the formal sector – this research is particularly focusing on "intermediate technologies"; and
4. The aim to diffuse industry

There is heterogeneity in such technological expectations which may be referred to as "customer preferences" [16]. The technology adoption lifecycle (TAL) is a statistical normal curve for understanding the acceptance of new technologies that divides the market into five segments, each occupying a single standard deviation: innovator, early adopter, early majority, late majority and a laggard [17]. The market segments are delimited by

chasms identifiable by technology gaps which signal the need for innovative re-design (represented by a line at every standard deviation) and any technology transfer between the market segments should diffuse by “crossing the chasm” starting from the innovators and developing its market sequentially towards the laggards.

The development of SMMEs should therefore be through a visible business operational structure that has product design at its core. Such a SMME – oriented development is two fold:

3. The SMME entity should have its business designed as a productive workspace where employees integrate their knowledge and experience in product design to realise the intended business goals; and
4. The collective action of several SMME should be designed such that they collectively and productively contribute in a complementary manner to the business goals through the TAL based on the fact that each market segment has a different set of customer preferences i.e. it should be appreciated that markets, as segmented and served by the SMME, should have the emerging characteristics similar to the TAL.

Hence, product design activity is inevitably intertwined with the business design activity [18]. Glass and Saggi [19] had put together a model that seeks to place ITech as part of TAL by linking foreign direct investment (FDI) and technology transfer from the MDC to the LDC. The diffusion of technologies may require segmentation of countries into markets along the TAL; to “cross the chasm” product designers need to re-design products within and across industries thereby transforming the economic base of these countries. The chasm of interest occurs between the early adopters and the early majority; this is because current research suggests that the difference between needs or factors that affect the innovators and early adopters are significantly different from those that affect the early majority, late majority and laggards [17], [20]. Therefore, it is worthwhile to treat the TAL as having two pseudo-market segments separated by an ITech gap (Figure 113).

In their investigation of the relationship between poor economic performances as signaled by the growth of gross domestic product (GDP) and low rates of investment (both public and private investment) in African countries, Devarajan et. al. [21] established that Botswana, Comoros, Equatorial Guinea, Lesotho, Mozambique, Sao Tome and Zambia were outliers; they found that the relationship was non-linear and that low investment as well as low performance growth rates seemed to be symptoms of the following five factors – all of which must be addressed concurrently and not in isolation:

1. Low usage of available capacity;
2. Limited absorption of acquired skills;
3. Loss of highly productive sectors (into low productivity);
4. The existence of state-owned enterprises; and
5. Poor policies.

The formula for calculating the formula for *GDP* is (Equation 1):

$$GDP = PC + I + G + (eX - i)$$

Where *PC* = Private Consumption, *I* = Gross Investment, *G* = Government Spending, *eX* = Exports and *i* = Imports

Equation 54: Gross Domestic Product

The current economic state for any country may be reflected by the GDP. The ideal economic state for any country that wants to diversify its economy through product design would be to have economic measures reflected in its product design activities. As may be concluded from Devarajan et. al. [21]), the national problem would be any gap in the following factors:

6. **Consumption:** The products consumed must be designed to address the basic needs or welfare of a nation and there must be adequate absorption of such products including employment of human skills. In such a case, the nation would be a consumer of both goods and services provided by human skill;
7. **Investment:** The increase in providing high capital per worker to boost and gain high output per worker and insure high returns from product design activities
8. **Government Expenditure:** Provision of good policies, state owned enterprises that support the product design practice and lack of constraints towards acquisition of skills by product design professionals.
9. **Export:** Goods and services provided by citizens to foreigners; and
10. **Imports:** Goods and services provided by foreigners to citizens.

The problem of the LDC may be addressed through implementation of product re-design strategies that target the ITech gap (Figure 113).

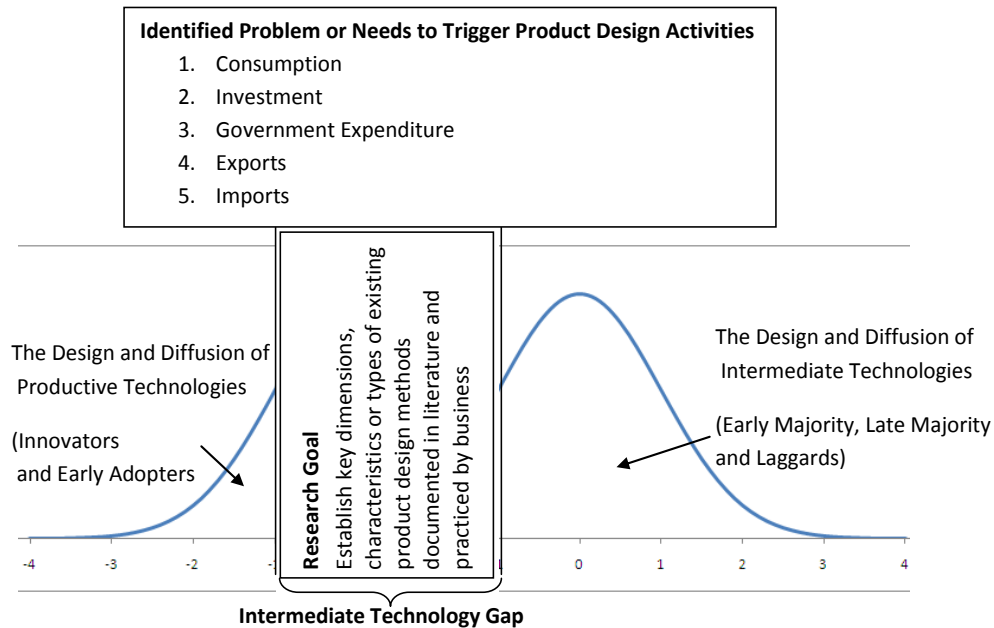
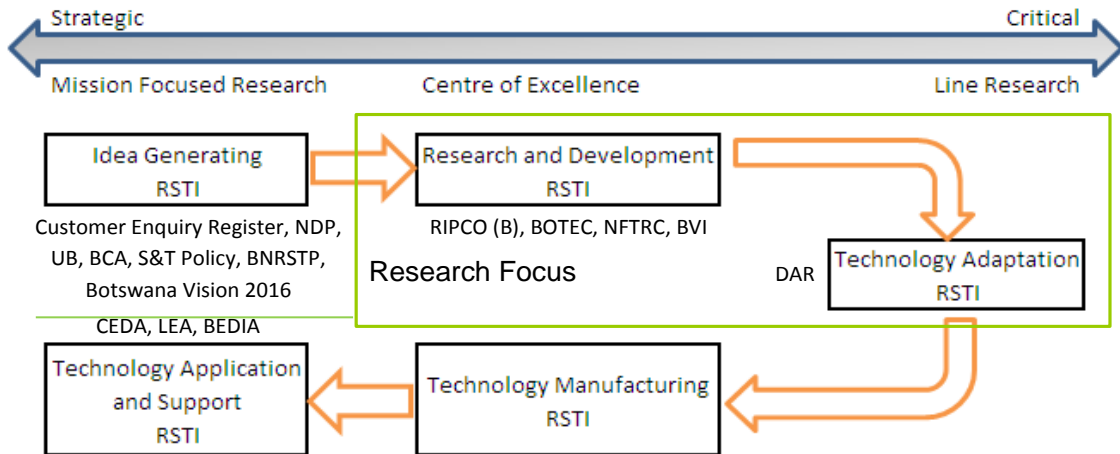

Figure 113: Crossing the Chasm to address an ITech gap [17]

3. The Product Design Guidelines (PDG)

The Science and Technology Policy for Botswana (S&TP-B) supports the empowering of national innovation organisations that design, develop, adapt and apply technology [22-23]. The Botswana National Science and Technology Plan (BNRTP) identifies priority research areas which are grouped into three main research platforms showing a continuum from critical to strategic [24-25].

The work environment within which the S&T Policy and the BNRSTP are implemented is comprised of RSTI whose performance may be characterised as illustrated Figure 114. Using internet, secondary data sources, observational visits and questionnaires, thirteen RSTI were identified in Botswana. It is convenient to propose a categorization of the activities performed by these RSTI. The Idea Generation RSTI (IG-RSTI) triggers and funds the national technology development and transfer activities and is typically not an entity but a policy implementation facility generated by policy formulating entities whose work are outside the scope of this research. The other RSTI develop projects and products to address the requirements of the IG-RSTI. Based on the activities of these RSTI, it may be stated that the role of the IG-RSTI is to identify the ITech gap and set in motion the activities to close it. The Technology Application and Support RSTI (TAS-RSTI) have one or more departments structured to assist entrepreneurs who source machinery and know-how from the Research and Development RSTI (R&D-RSTI). The Technology Adaptation RSTI (TA-RSTI) provides knowledge support to the R&D-RSTI. This categorization of RSTI is in line with the basic needs of the LDC from the work of Whitby [5]. In terms of the BNRSTP, the IG – RSTI and the TAS – RSTI would be mission focused, the centre of excellence would comprise R&D – RSTI while line research would be through the TA – RSTI. Visibly, Botswana may appear not to have a centre of excellence in manufacturing i.e. it appears there is no Technology Manufacturing RSTI (TM – RSTI).



Key:

- BCA:** Botswana College of Agriculture
- BOTEC:** Botswana Technology Centre
- CEDA:** Citizen Entrepreneurial Development Agency
- LEA:** Local Enterprise Authority
- BEDIA:** Botswana Export Development and Investment Authority
- RIPCO (B):** Rural Industries Promotions Company (Botswana)
- UB:** University of Botswana
- BVI:** Botswana Vaccine Institute
- DAR:** Department of Agricultural Research
- NFTRC:** National Food Technology Research Centre
- NDP:** National Development Plan

Figure 114: Categorisation of RSTI according to Research Platforms required by the S&TP-B and BNRSTP

One way by which the ITech gap may be addressed is through the development of product design guidelines. The engineering product design guidelines that are proposed by this research are comprised of a catalogue of the quantitative and qualitative engineering and management techniques inclusive of those used across the following nine product design methodologies documented in literature: Axiomatic Design, Quality Function Deployment (QFD), Reverse Engineering and Re-Design, Robust Design (Taguchi Methods), Stage-Gate New Product Development, Systematic Engineering Design Approach (Pahl and Beitz Method), Teoriya Resheniya Izobretatelskikh Zadatch (TRIZ), Total Design and R4D. It is observed that product designers, especially in the LEDC, are confronted with, and must choose from among, the many product design methodologies; this is the case even though the world is abounding with examples of product failure across a lot of industrial applications and stretching more than a century (Table 56) – there is need for a product design guidelines that are suitable for their needs.

			Year
Disasters	Marine	Loss of RMS Titanic	1912
	Mining	Senghenydd Colliery	1914
		Creswell Crag	1954
		Markham Colliery	1973
	Structural	Tay Bridge	1879
		Summerland Fire	1965
		Alexander Kielland Oil Rig	1980
	Aerospace	Comet Crashes	1955
		Challenger Space Shuttle	1988
	Nuclear	Chernobyl	1984
Business	Kodak Infringement	1986	
	BP Infringement	1998	
Serious Accidents	Automotive	Ford Pinto Fires	1967
		Fiat Mirafiori Fires	1978

Table 56: Examples of Product Failures by Severity [26]

The product design guidelines proposed by this research are comprised of the following features:

1. The conceptual framework which is a graphical co-ordinate system of forty-two engineering and management techniques used by designers to carry out product design activities. The conceptual framework is arranged according to two orthogonal axes that describe the structure of product design process; firstly, the need – function – form structure as observed by Otto and Wood [27-28] and Wood and Lindsey [29] and

secondly the divergent – convergent structure as posited by Pugh [18] and Cross [30]. In addition, the conceptual framework takes account of the product design drivers [28], [31], product realisation process and the product development lifecycles.

2. The product design method notation which is a register of the expression derived from the conceptual framework and is used to denote a group of techniques being implemented, or intended for implementation. Such expressions are henceforth referred to as product design procedures and aid in the selection as well as communication of these product design procedures among the design team – in this report this is achieved via dots and lines (Figure 4); and
3. The configuration scheme which provides a clear link between components, sub-assemblies, products, projects, programmes and policies.

At the time of policy implementation roll out by the IG-RSTI, the configuration scheme should be detailed out to fund and control technology development activities through a monitoring system comprising of the product design method notation (Figure 115).

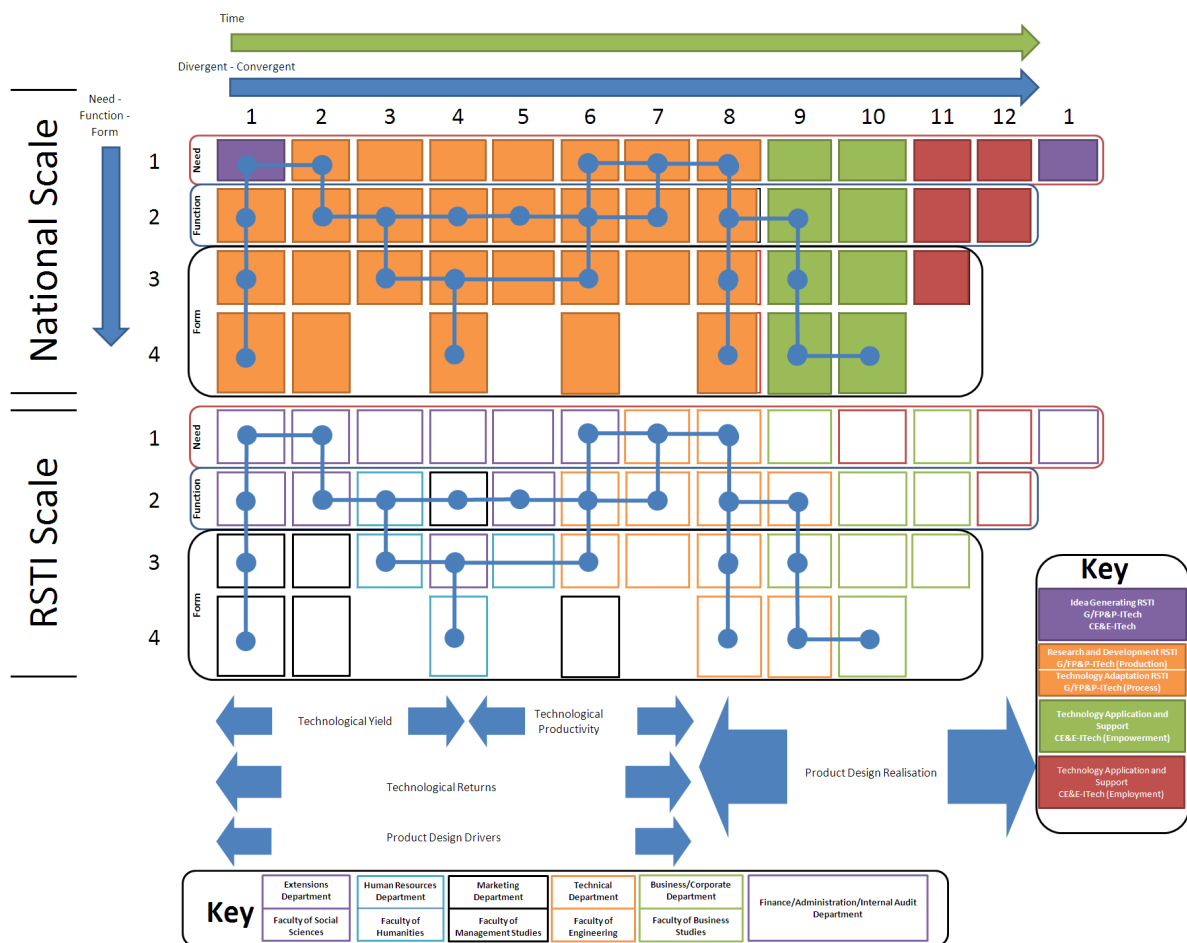

Figure 115: Strategic Workforce Planning for RSTI based in LDC. The dots indicate the techniques utilised in case study work to develop products for the Integrated Support Programme for Arable Agricultural Development (ISPAAD) and Young Farmers Fund (YFF) Programme

4. Evolving the Appropriate Technologies into Intermediate Technologies

In this research, it is proposed that a group of products that share the same human and non-human resources in an institution be referred to as a project and a programme be referred to as a group of projects that share a common pool of resources in institutions; a policy is comprised of a battery of programmes. The implementation of any ITech programme must identify all of its projects and products. Of necessity, the product design specifications of such projects and products should be synchronised within the programme.

During the study period from January 2008 to December 2010, case study work was conducted in conjunction with RIPCO (B). Products which are associated with the ISPAAD programme dominated the product design activities at the Project Development Section of RIPCO (B). ISPAAD, as a programme concerned with products for grain or food production and processing, should deal with eleven grain or food products which have been identified from literature [32-34]. These products can be grouped as projects for particular grain varieties; three projects were undertaken with regard to maize grain, *morama* bean and sorghum grain. Traditionally, these projects were executed by RIPCO (B), through memoranda of agreement with DAR, NFTRC and UB (Figure 114). Additionally, this research proposes to include the TAS-RSTI which administers the Young Farmers Fund (YFF). Funding and priorities for these programmes are provided through NDP 10 for the period 2009 – 2014 [35].

Figure 116 shows that the ISPAAD and YFF benefit from an array of technology development policies as spelled out in the National Policy on Agricultural Development [36].

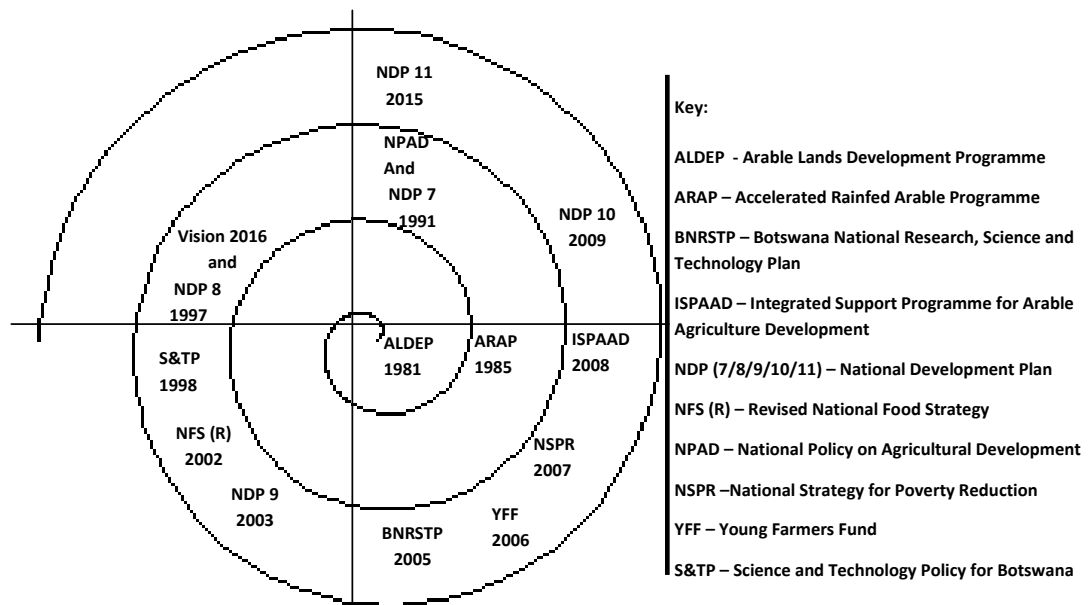

Figure 116: The Spiral Model Life Cycle of the Arable Agricultural Policy and Development Planning Programmes in Botswana

The product design drivers which are part of the conceptual framework provide activity measures that should be added in the calculation of GDP by any country that wants to transform its economy through product design. The product design drivers may be specifically documented as product design specifications and are sub-divided into two, using terminology suggested by Foster [37]:

1. Technological Yield (TY) which is a measure of the extent to which the difference between the current technical performance and the technical performance limitations set by laws of nature is translated into actual technical performance. TY is determined by the first set of four columns of the conceptual framework and is inherently concerned with industrial competitiveness; and
2. Technological Productivity (TP) which is the amount of effort (including resources) invested to design a product taking advantage of the difference between the current technical performance and the technical performance limitations set by laws of nature. TP is determined by the second set of four columns of the conceptual framework.

Product realization (PR), which is also part of the conceptual framework, refers to the transformation of the product design drivers into realised product concepts. PR is determined by last set of six columns of the conceptual framework.

The product design method notation records the portion of the conceptual framework that is used to address the requirements of particular policies. The notation is shown as big dots connected by thick lines in Figure 4. This notation is cascaded to programmes, projects and products as recorded by the configuration scheme. The syntax of the configuration scheme is (Expression 1):

Expression 1: Syntax of the Configuration Scheme

For example, the maize dryer product would have the following reference (Expression 2):

ISPAAD.YFF – PDG – Maize - Dryer

Expression 55: Syntax of the Maize Dryer (Excluding the Policies, Sub-Assemblies and Components)

The TY requires the eleven products associated with ISPAAD to be prioritized. The analytical Kano model technique developed by Xu et. al [38] has been suitably used for such an activity as this case study (Figure 117).

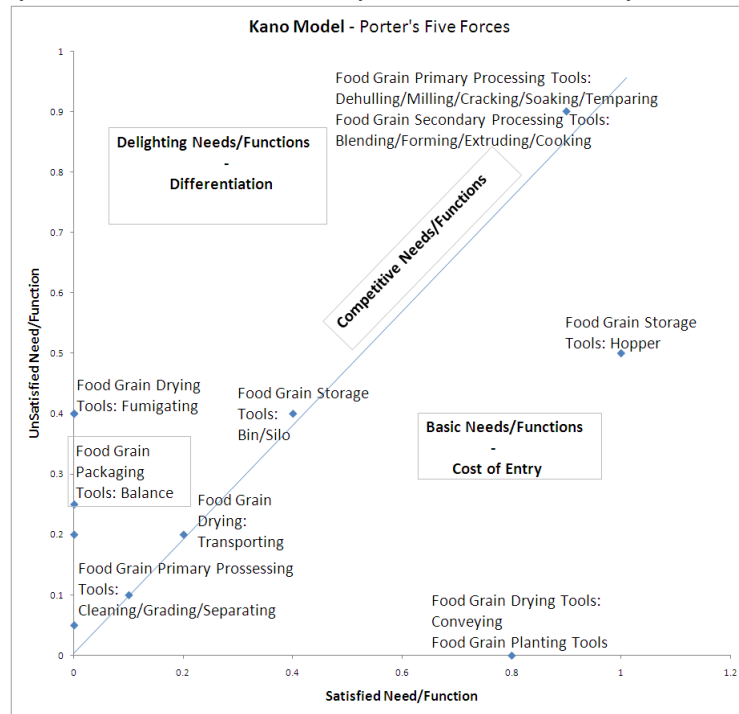

Figure 117: The Analytical Kano Model and Porter's Five Forces used to prioritise products for the ISPAAD and YFF Programmes

Porter [39] encourages the establishment of industrial districts to improve industrial competitiveness i.e. the TY (Figure 117 and 118). Figure 118 shows the arbitrary allocation of technologies to the geographical locations in Botswana that is meant merely as an illustration. This is because industrial districts tend to foster innovation and the dissemination of information caused by local competition and industrial concentration stimulates productivity growth. Recently, Botswana Export Development and Investment Agency (BEDIA) launched the Botswana Brand to boost the culture of productivity. The Botswana Brand logo shows the sun with rays emerging from the centre. This helps to stimulate product design activities as it shows a link with the divergent – convergent structure of the product design process. In this case the Botswana Brand figuratively shows divergence through exports. To address the needs within Botswana requires convergence which is well demonstrated by the *kgotla*. The *kgotla* is a productive traditional cultural meeting place where communities assemble. It is delimited by tree log pillars assuming a horse-shoe shape. However, the *kgotla* concentrates more on speeches and, for agricultural activities, it makes the pronouncements to start planting. The harvesting period takes place through *molaletsa* activities where communities participate in self help enterprise. This research proposes a similar arrangement implemented through the PDG to set up a hub and satellite industrial clusters with ISPAAD as the customer and the YFF as the supplier. The hub would be comprised of RSTI and the satellites would be comprised of YFF suppliers.

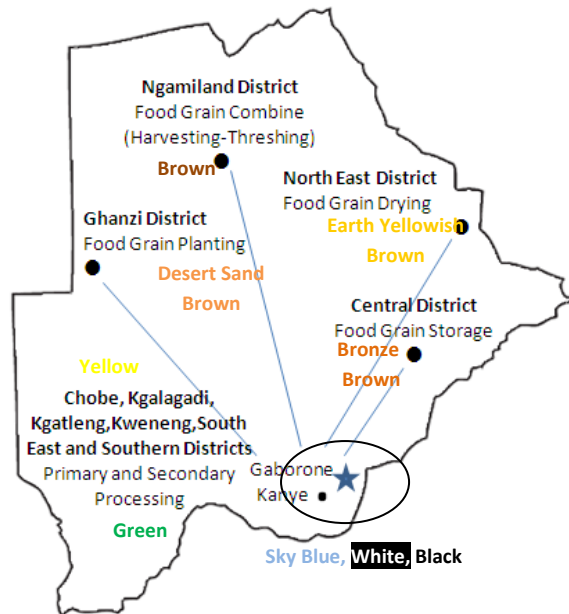

Figure 118: An Arbitrary Institutional Distribution Cluster (or Industrial Districts) for the ISPAAD and the YFF Programme showing Dots reminiscent of the Botswana Brand and the *Kgotla* Pillars and the colours from the Botswana Brand

Modular products provide improvements to product design by introducing variants due to addition of sub-assemblies or modules to a product platform, to enable performance of different overall functions. This means that a common set of sub-systems must be used for the product family. This may be achieved through modular products. A bulk storage bin was designed as part of the case study to be the product platform for ISPAAD. In general, the sequence or cluster of creativity methods used in this research is as illustrated in Figure 119. Figure 120 shows the implementation of these creativity methods applied to the bulk storage bin. From the bulk storage bin, a product family comprised of eleven products was designed to address the needs of ISPAAD.

The YFF as a supplier would be operational through a supply chain of related modular products. Each YFF supplier may be further developed into an original equipment manufacturer (OEM) for specific components and sub-assemblies. As a pool of OEM, the YFF would be in a position to export commodities to markets outside Botswana and contribute to the Botswana Brand.

It must be noted that the transformation of the traditional artifact requires the application of mathematics and engineering principles; in the event that intellectual property rights are infringed, it should be easy to alter and localize the new technologies. Intellectual property is a business way to progress technical performance of products towards the limits set by natural laws – a clear contribution to the product design drivers. The LDC stand to benefit from indigenous technologies that are innovatively transformed in this manner.

Evidently, the proposed product design guidelines may be used to evolve appropriate technologies and by being based on methods such as R4D the guidelines would also enable the downscaling of productive and automation technologies.

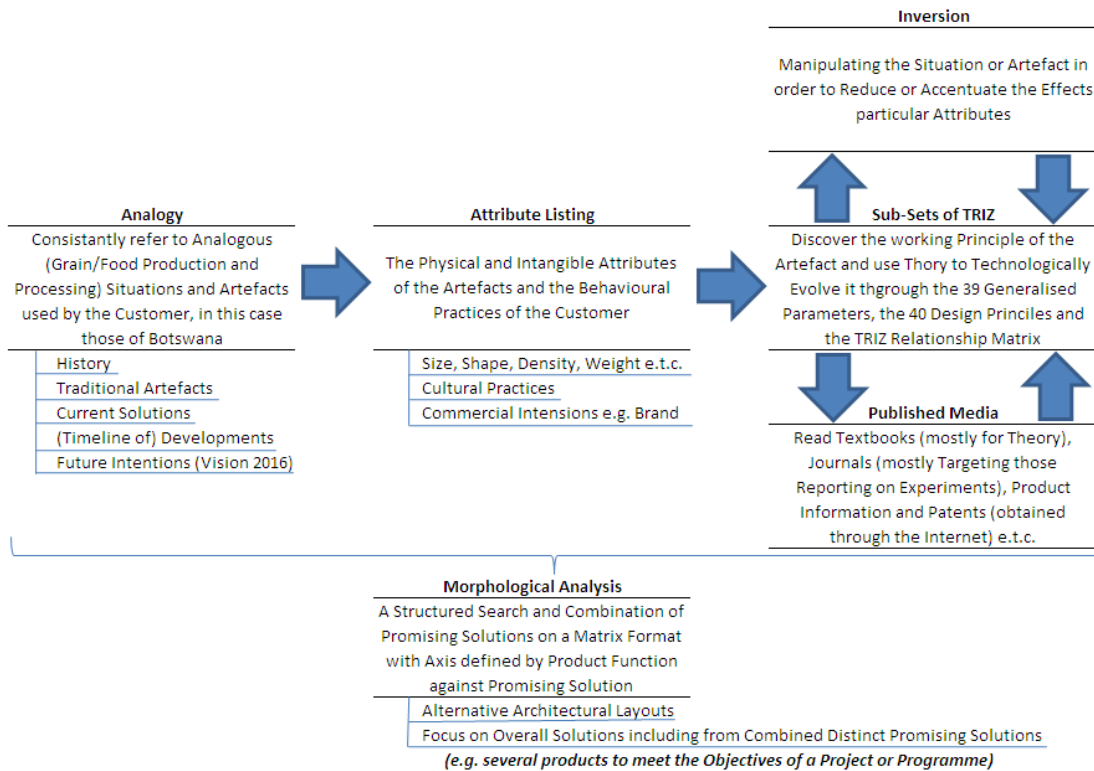

Figure 119: Sequence or Cluster of Creativity Aiding Methods

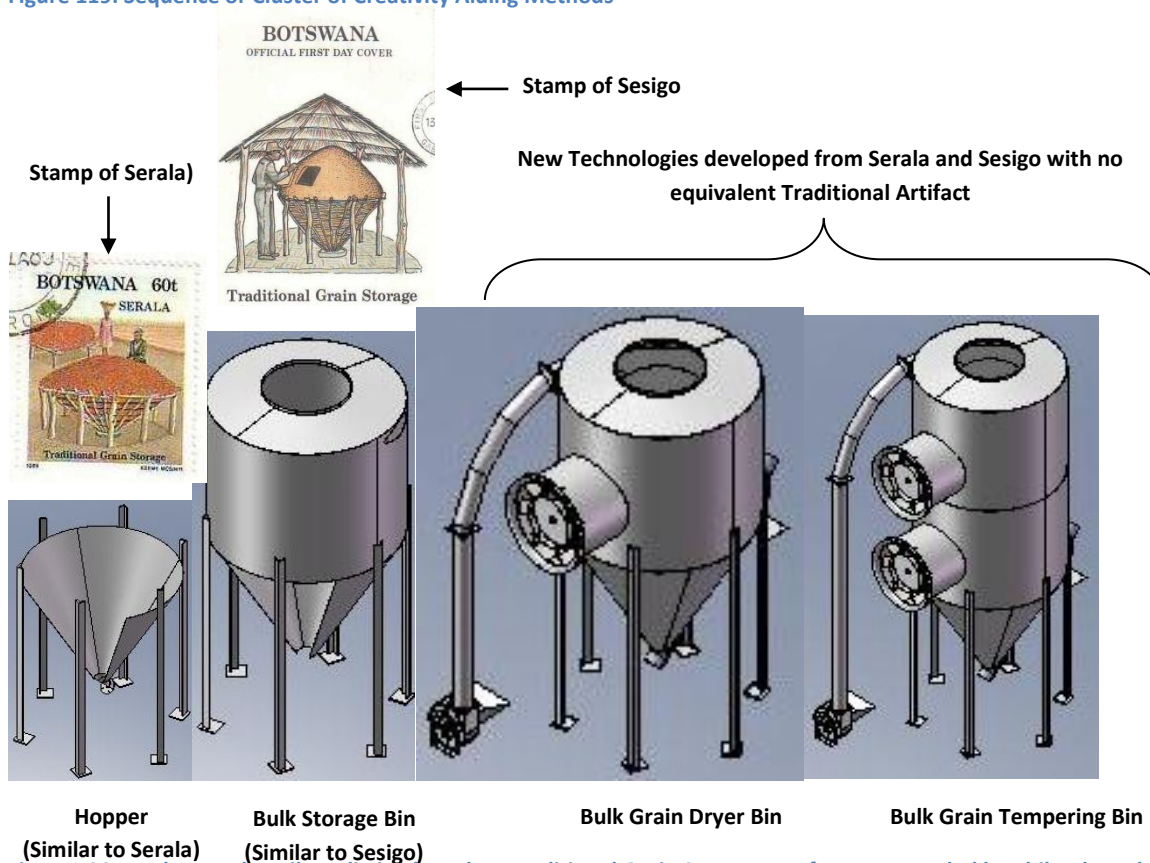

Figure 120: Analogy and attribute listing based on Traditional Grain Storage Artefacts as recorded by philately and the internet (Source: Stamps pictures adapted from http://images-01.delcampe-static.net/img_large/auction/000/118/923/204_001.jpg)

5. Conclusions

Engineering product design is a key factor in the economic development of Botswana and other LDCs. Well-structured product design guidelines can assist the process, but addressing only the design of the physical hardware will not guarantee success. The product design guidelines proposed in this research have been developed to be able to take account of the regional and societal characteristics within Botswana and also of other African countries.

References

1. Schumacher, E., F., "Small is Beautiful: A Study of Economics as if People Mattered." London, United Kingdom: Blond and Briggs, 1973.
2. Vision 2016 Taskforce, "A Framework for Long Term Vision of Botswana." Gaborone, Botswana: Botswana Press Agency, 1997.
3. Akin, G., and Hopelain, D., "Finding the Culture of Productivity", *Organisational Dynamics*. 14 (3), 1986. pp. 19 - 32
4. Akao, Y., Harada, A., and Matsumoto, K., "Quality Function Deployment and Technology Deployment." In: Y. Akao, ed.. "Quality Function Deployment: Integrating Customer Requirements into Product Design." New York, United States of America: Productivity Press, 1990.
5. Whitby, G., "Intermediate Technology Research in Botswana", *Research for Development in Botswana*. Proceedings of a Symposium held by the Botswana Society at the Gaborone Sun Conference Centre August 19 – 21 1985. Gaborone, Botswana: The Botswana Society, 1985.
6. Bassey, M., and Schimidt, O., "Abrasive Disk Dehullers in Africa: From Research to Dissemination." Ottawa, Canada: International Development Research Centre, 1989.
7. Reichert, R., Youngs, C., "Dehulling Cereal Grains and Grain Legumes for Developing Countries: I. Quantitative Comparison between Attrition and Abrasive Type Mills", *Cereal Chemistry*. Minnesota, United States of America: American Association of Cereal Chemists, 53(6), 1976. pp. 829 – 839.
8. Reichert, R., Youngs, C., "Dehulling Cereal Grains and Grain Legumes for Developing Countries: II. Chemical Composition of Mechanically and Traditionally Dehulled Sorghum and Millet", *Cereal Chemistry*. Minnesota, United States of America: American Association of Cereal Chemists, 54(1), 1977. pp. 174 – 178.
9. Schmidt, O., G., "The Sorghum Dehuller: A Case Study in Innovation", *International Institute for Environment and Development's Conference on Sustainable Development*. London, England 1987.
10. Inger, D., "Poverty and Profits: The Work of RIPCO, GTZ GATE." Eschborn, Germany: Deutsche Gesellschaft fur Technische Zusammenarbeit 4, 1993.
11. Hamilton, A., "A Review of Post – Harvest Technologies, Botswana." Ottawa, Canada: Canadian University Service Overseas, 1975, pp. 200
12. Mmapatsi, M. D., and Maleke, J., M., "Development of an Institutional Support Systems for Sorghum Milling Technology, Drought Tolerant Crops for Southern Africa" *Proceedings of the SADC/ICRISAT Regional Sorghum and Pearl Millet Workshop*, 25-29 Jul 1994. International Crops Institute for Semi-Arid Tropics. Bulawayo, Zimbabwe: Socioeconomics and Policy Program, 1996. pp. 7 - 18
13. Rohrbach D., Mupanda, K., and Seleka, T., "Commercialisation of Sorghum Milling in Botswana", *International Crops Institute for Semi-Arid Tropics*. Bulawayo, Zimbabwe: Socioeconomics and Policy Program, 2000.
14. Rosenberg, N., "On Technological Expectations", *The Economic Journal*. New Jersey, United States of America: Wiley-Blackwell Publishing 86 (343), 1976. pp. 523 - 535
15. Livingstone, I., "Alternative Approaches to Small Industry Promotion: Tanzania, Kenya and Botswana," *Centre of African Studies Conference on Industrialisation in Africa* Edinburgh Nov 30 – Dec 1st 1979. Norwich, United Kingdom: School of Development Studies, 1980.
16. Green, P., E., and Krieger, A., M., "Segmenting Markets with Conjoint Analysis," *Journal of Marketing* Chicago, United States of America: American Marketing Association, 55, 1991, pp. 20 – 31
17. Moore, G. 2ed. "Crossing the Chasm" West Essex, United Kingdom: Capstone, 1998.
18. Pugh, S., "Total Design: Integrated Methods for Successful Product Engineering." Reading (MA), United States of America: Addison-Wesley Publishing Company, 1991

19. Glass, A., J., and Saggi, K., "International Technology Transfer and the Technology Gap," *Journal of Development Economics*. Amsterdam, The Netherlands: Elsevier, 55, 1998. pp. 369 -398
20. Sroufe, R., Curkovic, S., Montabon, F., and Melnyk, S., A., *The New Product Design Process and Design for the Environment: "Crossing the Chasm"*, International Journal of Operations Management. Edinburgh, United Kingdom: University Press, 20 (2), 2000, pp. 267 – 291
21. Devarajan, S., Easterly, W., R., and Pack, H., "Is Investment in Africa Too Low or Too High? Macro and Micro Evidence," Policy Research Paper No. 2519. Washington DC: United States of America: The World Bank Development Research Group, Public Economics and Macroeconomics and Growth, 2001.
22. Botswana Technology Centre, "Science and Technology Policy for Botswana." Gaborone, Botswana: Botswana Press Agency, 1998.
23. Ntshole, P., "Botswana Technology Centre," Regional Seminar for the Benefits of the Intellectual Property System for Universities, University Researchers and Research and Development Organisations: Country/Organisation Reports. Dar es Salaam, Tanzania: World Intellectual Property Organisation, 2000.
24. Keatimilwe, K., "Botswana National Research Science and Technology Plan." Stellenbosch, South Africa: Council for Scientific and Industrial Research, 2005.
25. Selaolo, E., "The National System of Innovation" [Presentation to the Innovation Forum] Dublin: 6 – 8 March, 2007
26. Lewis, P. R., "Polymer Product Failures." Shropshire, United Kingdom: iSmithers RAPRA Technologies LTD, 2000.
27. Otto, K., and Wood, K., "Customer Integration Systematic Design," *Journal of Integrated Design and Process Science*. Amsterdam, The Netherlands: IOS Press 3 (4) 199, .pp. 61 - 74
28. Otto, K., N., and Wood K., L., "Product Design: Techniques in Reverse Engineering and New Product Development." New Jersey, United States of America: Prentice-Hall, 2001.
29. Wood, K., L., and Linsey, J., S., "Understanding the Art of Design: Tools for the next Edisonian Innovators," *The Psychology of Learning and Motivation*. Amsterdam, The Netherlands: Elsevier, 47, 2007,.pp. 65 – 122
30. Madhusudan, T., "An Agent – Based Approach for Coordinating Project Design Workflows," *Computers in Industry*. Amsterdam, The Netherlands: Elsevier, 56, 2005. pp. 235 - 259
31. Cross, N., "Engineering Design Methods: Strategies for Product Design." West Sussex, United Kingdom: John Wiley & Sons, 1994.
32. Bainer, R., Kepner, R., and Barger, E., "Principles of Farm Machinery." New Jersey, United States of America: Wiley, 1955.
33. Shippen, J.,and Turner, J.,. "Basic Farm Machinery." Oxford, United Kingdom: Pergamon Press, Vol 1, 1966a
34. Shippen, J.,and Turner, J., "Basic Farm Machinery." Oxford, United Kingdom: Pergamon Press, Vol 2, 1966b.
35. Government of Botswana, "National Development Plan 10." Gaborone, Botswana: Botswana Press Agency, 2009.
36. Government of Botswana, "National Policy on Agricultural Development." Gaborone, Botswana: Botswana Press Agency, 1991.
37. Foster, R., 1986. Timing Technological Transitions. In: M., Horwitch, e.d., "Technology in the Modern Corporation: A Strategic Perspective." Oxford, United Kingdom: Pergamon Press, 1986.
38. Xu, Q, Jiao, R., Yang, X., and Helander, M., "An Analytical Kano Model for Customer Need Analysis," *Design Studies*. Amsterdam, The Netherlands: Elsevier 30 2008. pp. 87 - 110

