

This item was submitted to Loughborough University as a PhD thesis by the author and is made available in the Institutional Repository (<https://dspace.lboro.ac.uk/>) under the following Creative Commons Licence conditions.



For the full text of this licence, please go to:  
<http://creativecommons.org/licenses/by-nc-nd/2.5/>

LOUGHBOROUGH  
UNIVERSITY OF TECHNOLOGY  
LIBRARY

AUTHOR/FILING TITLE

TAYLOR, P T

ACCESSION/COPY NO.

036000039

VOL. NO.

CLASS MARK

LOAN COPY

~~17 MAY 1991~~

~~17 JUN 1991~~

- 5 MAR 1993

036000039 8



THIS BOOK WAS BOUND  
BY BADMINTON PRESS  
AT THE HALFCROFT  
SYSTEM  
LEICESTER LE1 8LD  
0533 60218

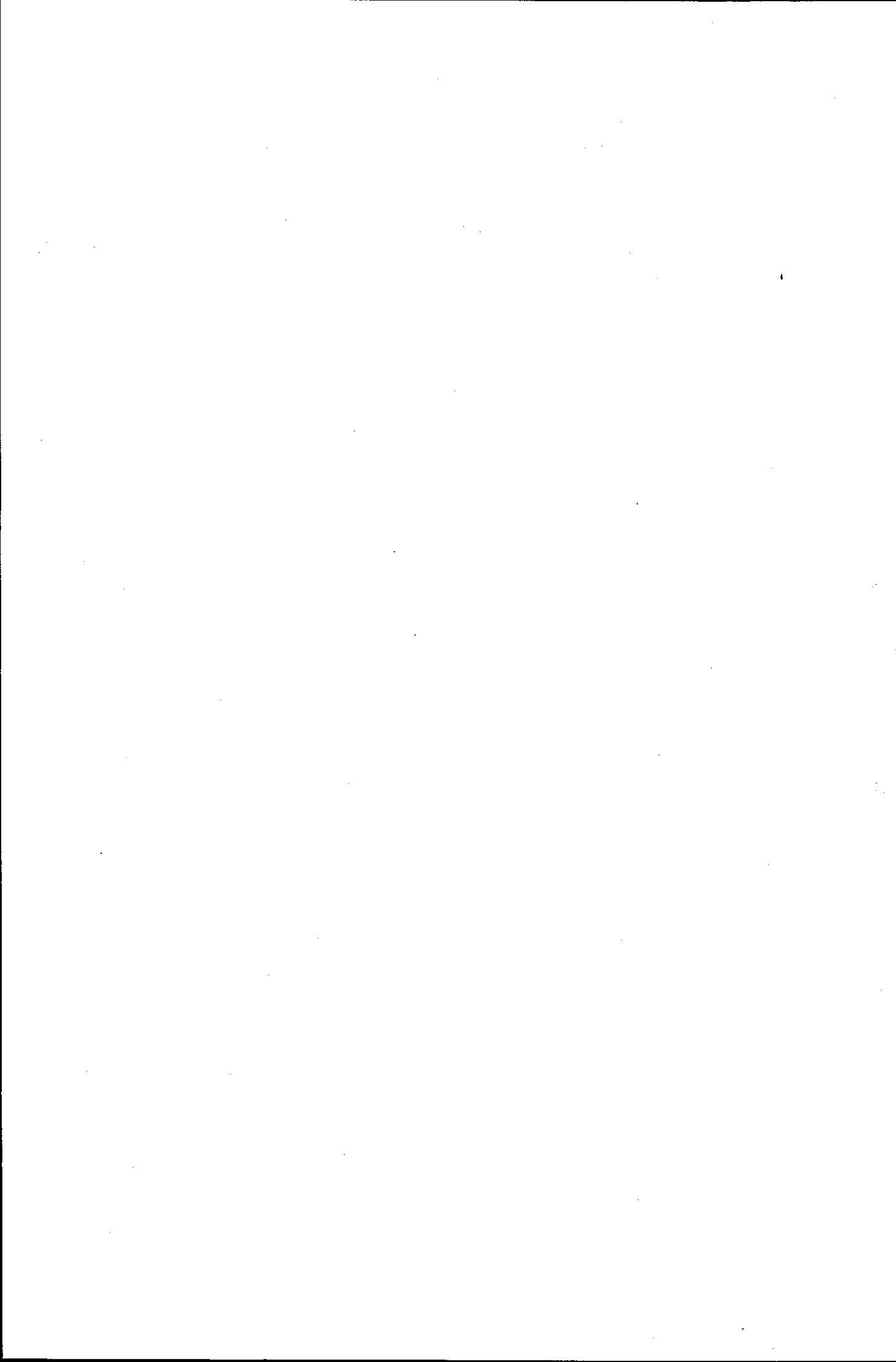

AN INVESTIGATION INTO THE  
MECHANISM OF ACTION OF  
NITROIMIDAZOLE ANTIBIOTICS

by

Peter Farnsworth Taylor

A Doctoral Thesis submitted in partial fulfilment of the  
requirements for the award of Doctor of Philosophy of the  
Loughborough University of Technology

June 1990

© Peter Farnsworth Taylor, 1990

Loughborough University of Technology Library	
Date	Jan 91
Class	
Acc No.	036 0000 39

y990834x

## CONTENTS

Acknowledgements	
Summary	
INTRODUCTION	1
RESULTS AND DISCUSSION	30
1 Radical anions of nitroimidazoles as putative reactive intermediates in the mechanism of action	33
1.1 Preparation of required nitroimidazoles	33
1.2 Electron spin resonance (e.s.r.) spectroscopic studies	45
1.3 Reduction reactions of nitroimidazoles	49
2 Putative dissociation of the nitro radical anion	61
2.1 Dissociation of the nitro radical anion	61
2.2 Synthesis of halogenoimidazoles	62
2.3 <sup>13</sup> C n.m.r. spectroscopy of halogenimidazoles	70
2.4 E.s.r. spectroscopy of halogenimidazoles	72
2.5 Reactions involving 5-imidazolyl radicals	75
2.6 Conclusions	89
3 Nitrosoimidazoles: possible intermediates in the mechanism of action of nitrosoimidazole antibiotics	91
3.1 Evidence for nitrosoimidazoles as putative reactive intermediates	91
3.2 Preparation of nitrosoimidazoles	94
3.3 E.s.r. spectroscopy of nitrosoimidazoles	111
3.4 Reactions of nitrosoheterocycles	113
3.5 Conclusions.	128
CONCLUSIONS	129
EXPERIMENTAL	132
Index of Experiments	132
1 General Procedures and Instrumentation.	138
2 Preparation of Nitroimidazoles	140
3 Reduction Reactions of Nitroimidazoles using Sodium Dithionite as Reductant	150
4 Electrochemical Reduction of Nitroimidazoles	153
5 Preparation of Halogenoimidazoles	158
6 Reduction Reactions of Halogenoimidazoles using Tributyltin Hydride as Reductant	166
7 Reduction Reactions of Halogenoimidazoles using Sodium/Liquid Ammonia as Reductant	170
8 Attempted S <sub>N</sub> 1 Reactions with Halogenoimidazoles	172
9 Preparation of Nitroso-Heterocycles	174

10	Reactions between Aromatic Amines and Nitroso Compounds	186
11	Reactions between Thiols and Nitroso-Heterocycles	190
	REFERENCES	198
	APPENDIX	

## LIST OF TABLES

1	The e.s.r. spectra of some substituted nitroimidazoles	45
2	$^{13}\text{C}$ N.M.R. spectroscopic chemical shift ( $\delta/\text{ppm}$ ) data for halogenoimidazoles	71
3	The e.s.r. spectra of selected halogenoimidazoles	72
4	e.s.r spectroscopic data for the nitrosoimidazole 111 radical anions	111



## ACKNOWLEDGEMENTS

I would like to thank:

The Boots Company Ltd., Bombay and the Boots Company p.l.c. (Nottingham) and S.E.R.C. for their financial support.

Dr. W.R.Bowman for his constant patient support and encouragement.

Prof. M.C.R.Symons (Leicester University) for running and interpreting the e.s.r. spectra.

Dr. J.R. Housley, Dr. Sudarsanam and Dr. Kaul, (The Boots Company p.l.c.) for their valuable advice.

Dr. P.Mitchell, (Electrochemistry Department at Loughborough University) for his assistance with the electrochemical reductions.

The Medicinal Chemistry Department at the Boots Company p.l.c., (Nottingham) for their friendly assistance during my industrial training period.

The academic staff, technicians and my colleagues at Loughborough University, Department of Chemistry, for their advice and encouragement.

## SUMMARY

The three most likely intermediates in the mechanism of action of 5-nitroimidazole antibiotics (the radical anions of nitroimidazoles, imidazol-5-yl radicals and 5-nitroso imidazoles) have been studied.

A range of 5-nitroimidazoles have been synthesised and analysed by electron spin resonance spectroscopy, (e.s.r.), and the electron spin density of their radical anions has been determined. Under reducing conditions known to proceed by a radical mechanism, a number of 5-nitro imidazoles did not undergo intramolecular cyclisation, [e.g. 1-(but-3-en-1-yl)-2-methyl-5-nitroimidazole], form stable covalent adducts with nucleotide bases, or dissociate to nitrite anions and the corresponding imidazol-5-yl radicals. This disproves the putative explanation for the generation of nitrite anions in the antimicrobial mode of action of 5-nitroimidazoles. A mechanism has been proposed to explain the release of nitrite in the mechanism of action of 5-nitroimidazoles.

Imidazol-5-yl radicals have been generated as reactive intermediates in reduction reactions, e.g. the reduction of 5-bromo-1,2-dimethylimidazole with Na/NH<sub>3</sub>/Bu<sup>t</sup>OH and the Bu<sub>3</sub>SnH. The imidazol-5-yl radical resulting from the Na/NH<sub>3</sub>/Bu<sup>t</sup>OH and Bu<sub>3</sub>SnH reductions of 5-bromo-1-(but-3-en-1-yl)-2-methylimidazole has been trapped by exo-radical cyclisation to yield a bicyclic imidazole product. <sup>13</sup>C NMR spectroscopy has been used to distinguish between 4- and 5-bromo- and iodo-imidazoles.

Nitroso-imidazoles and -indoles have been synthesised and reacted with thiols as a model for possible reactions with intracellular repair thiols which may play a part in the mode of action of 5-nitrosoimidazole antibiotics.

## INTRODUCTION

### The History of Antibiotics

The term antibiotic is used to describe any compound which is effective in the treatment of disease caused by microorganisms. Originally, an antibiotic was a naturally occurring substance, either inorganic or organic, which was used with or without any preparation. Compounds once known as chemotherapeutics, that is, man made substances, are now usually also referred to as antibiotics.

The development of antibiotics can be roughly divided into four historical phases. Before the seventeenth century minerals and plants were used to treat illness, largely in ignorance, although some remedies contained beneficial chemicals. By the end of the nineteenth century, an extract of cinchona tree bark was used in the treatment of malaria and the subsequent development and use of alkaloids derived from natural products led to other treatments. Antimicrobial chemotherapy really began with Ehrlich's magic bullets around 1900, when he discovered that rabbits infected with syphilis could be cured by certain dyes including trypan red. Over the next twenty years a number of related compounds were developed including salvarsan, suramin and mepacrine. In 1935 Domagk discovered the first of the sulphonamides, prontosil, which was effective against streptococcal infections. The announcement by Florey and his team in 1940 of the chemotherapeutic potential and potency of penicillin, discovered by Fleming in 1929, marks the start of the modern antibiotic revolution which still continues today.

### General Modes of Action

The range of compounds used as antibiotics today is vast,

but their modes of action can be generalised.

- (1) Inhibition of the cell wall function - compounds which cause a breach in the cell wall leading to cell death by virtue of the internal osmotic pressure. The group includes the penicillins and cephalosporins which interfere with the biosynthesis of the cell wall by inhibiting the formation of peptides from amino acids.
- (2) Inhibition of membrane function - in addition to surfactants, antiseptics and phenol-based disinfectants which cause disruption of the cell membrane, this group can be divided into three groups.
  - (a) The tyrocidins, polymycins and polyene antibiotics, which function by disruption of the cell membrane.
  - (b) The gramicidins, valinomycin, nonacitin and polyether antibiotics, which act by altering the cell membrane permeability.
  - (c) Compounds such as oligomycin, antimycin and dicyclohexyl-carbodiimide, which interfere with membrane enzyme systems.
- (3) Inhibition of protein synthesis - These compounds bind to the ribosomes of the target cell thereby preventing the synthesis of proteins. This category can also be further divided according to the type of site on the ribosome, 30 S (aminoglycoside antibiotics and tetracyclines) or 50 S (chloramphenicol, erythromycin, clindamycin and fusidic acid), to which they bind.
- (4) Inhibition of nucleic acid function - This group covers a wide variety of modes of action.
  - (a) Antifolate drugs which inhibit or disrupt nucleotide biosynthesis by inhibiting the reduction of

dihydrofolic acid to tetrahydrofolic acid by the enzyme dihydrofolate reductase. They include pyrimethamine, methotrexate and trimethoprim.

- (b) Antimetabolites which inhibit the synthesis of naturally occurring compounds by blocking their site of production. They include purine and pyrimidine analogues.
- (c) Intercalating drugs which inhibit the synthesis of RNA primarily but also DNA at higher concentrations. Examples include proflavine, ethidium and actinomycin D.
- (d) Drugs which cross-link DNA which operate by alkylation of DNA bases forming covalent linkages between opposite strands of the helix. They include nitrogen mustards, mitomycin, ethylenamines and porfiromycin.
- (e) Drugs which inhibit the transcription of enzymes and DNA replication. They include rifampicin, arylhydrazinopyrimidines and nalidixic acid.
- (f) Drugs which cause strand breakages in DNA, such as bleomycin, neocarzinostatin, nitrofurans and nitroimidazoles.

## Nitroimidazole Antibiotics

Nitroimidazoles are antibiotics whose mode of action is thought to fall into the latter category - drugs which cause DNA strand breakages. Despite the general mode of action, little is known about the specific mechanisms involved. A precise knowledge of the reactions in nitroimidazole mode of action would almost certainly allow for the design of more effective drugs.

### What is a Nitroimidazole Antibiotic?

There are three possible isomeric structures with the nitro group substituted at C-2 (1), C-4 (2) or C-5 (3) in the heterocyclic ring.

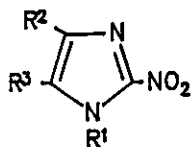

2-NITRO (1)

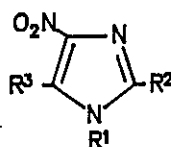

4-NITRO (2)

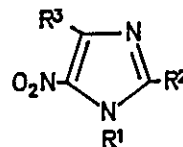

5-NITRO (3)

Of these, only the 2- and 5-nitroimidazoles display appreciable biological activity.

### Mode of Action

The important feature of nitroimidazole antibiotics is their selective activity towards anaerobic cells (without oxygen), indicating that they either interfere with some biochemical process unique to anaerobic cells or that aerobic cells can counter the effect of the nitroimidazole antibiotics.

It was shown by Edwards *et al* 1,2 in studies with Trichomonas vaginalis that the normal production of H<sub>2</sub> gas was inhibited but that the evolution of CO<sub>2</sub> gas was unaffected by nitroimidazoles. Later it was shown that the H<sub>2</sub> gas originated from the pyruvate phosphoroclastic system (see Figure 1).

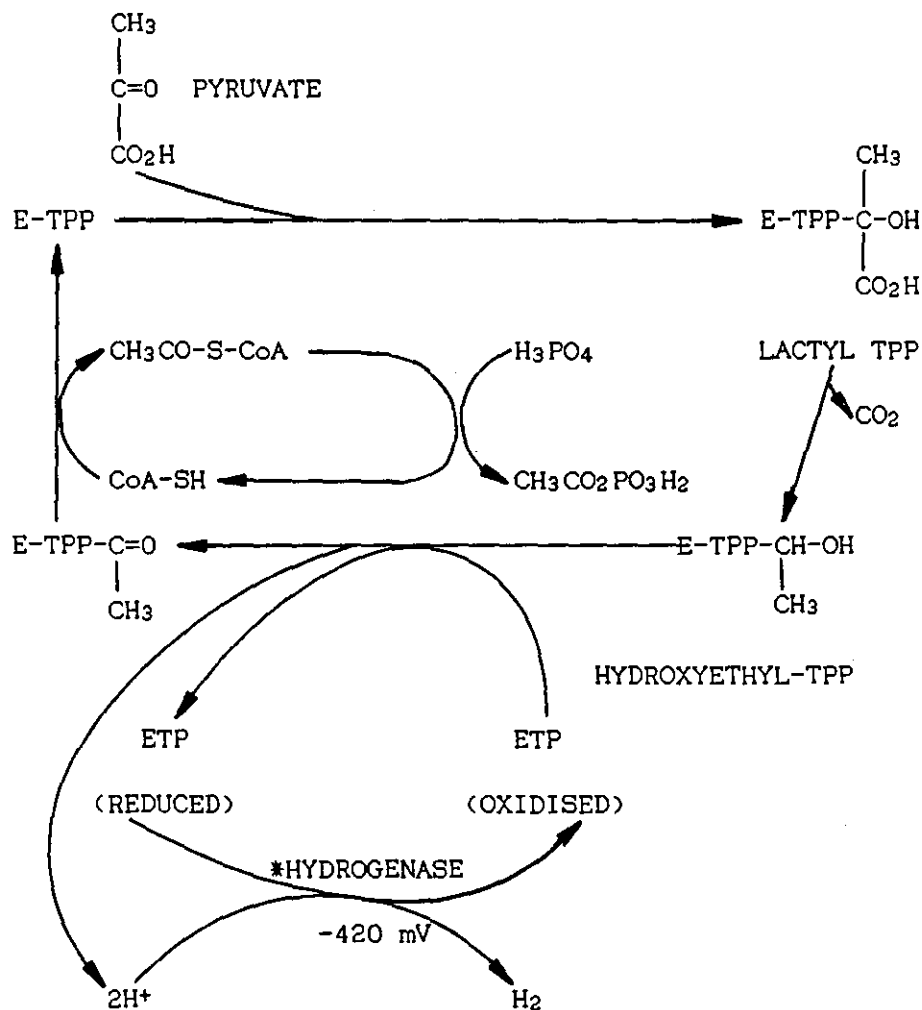

\* - position of interaction with nitroimidazoles

E - enzyme complex

TPP - thiamine pyrophosphate

ETP - electron transfer protein

#### The Pyruvate Phosphoroclastic System

Figure 1.

In this reaction, since H<sub>2</sub> evolution was inhibited and acetyl phosphate and CO<sub>2</sub> was not, it indicated that the drug was acting at the hydrogenase step, either directly with the enzyme or as an electron sink accepting electrons from the reduced electron transfer protein in *T. vaginalis* or reduced

ferredoxin in Clostridia. The lethal step does not appear to be the reduction of the nitro group because the evolution of H<sub>2</sub> recommences once the drug is consumed.

From these observations it was assumed that the reduction products of the drug were the active species in the mode of action.

The reduction of nitroimidazoles, unlike nitrofurans, does not require a nitroreductase enzyme, but is achieved byferredoxin oxireductase which has a comparable reduction potential of around -430 mV. It is interesting to note that the lowest reduction potential so far discovered in aerobic cells is -350 mV, insufficient to reduce nitroimidazoles. The reduction potential not only explains the lack of activity toward aerobes but also the inactivity of the 4-nitroimidazoles which have a higher reduction potential 3,4 than the 2- or 5-nitroimidazoles.

In addition to the redox potential differences between aerobic and anaerobic cells, the O<sub>2</sub> present in aerobic cells can react with the nitro product, in what is referred to as the O<sub>2</sub> futile cycle, to regenerate the nitroimidazole and produce superoxide (Equation 1). The immediate removal of the reduced material from the cell would prevent further reaction and therefore inhibit the activity.

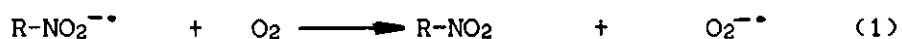

Nitro-Radical Anion                      Nitroimidazole                      Superoxide

Studies by Edwards et al <sup>5</sup>, showed that metronidazole decreased the hyperchromicity and renaturation of DNA, decreased the viscosity of DNA, decreased the molecular weight of DNA as shown by agarose gel electrophoresis, increased the amount of single-strandedness of DNA as shown by hydroxyapatite chromatography and decreased the amount of intact helix in DNA as shown by binding of acridine orange.



The same authors also show that metronidazole-treated DNA sediments to a less dense region in sucrose sedimentation gradients and inhibits the action of DNAase-1.

With regard to the site of attack by the reactive reduced species, no conclusive evidence has been published although it is possible that the reduced species alkylates the DNA, and enzyme or some other macromolecule causing cell death. Direct interaction with DNA, by the formation of covalent adducts<sup>6-9</sup> or by single strand breakage<sup>10-16</sup> have both been suggested as possible modes of action. Cellular breakages are somewhat controversial as they are not always observed<sup>8,9</sup>, and the nature of the DNA base which is alkylated is unclear. Contradictory reports that covalent bond formation is proportional to cytosine and guanine<sup>6,8,9,17</sup> as well as to adenine and thymine<sup>10,11,14</sup> have both been published. In all of these studies, no covalent adduct has actually been isolated.

Evidence for the reaction between reduced nitroimidazole and cellular thiols, such as glutathione or cysteine<sup>19-21</sup>, at the C-4 position has been proposed. Formation of such adducts would remove compounds which play a central role in cell repair mechanisms and would therefore lead eventually to cell death. Cellular repair thiols are not specific to anaerobic cells and if this is the main mode of action the only plausible explanation for the anaerobic selectivity displayed by nitroimidazoles could be based on the differences in redox potentials in anaerobic and aerobic cells.

Although DNA would appear to be the site of attack in bacteria, the carbohydrate metabolism in protozoa is also a possible candidate<sup>22</sup>. In protozoa, the inhibition of H<sub>2</sub> gas is irreversible and cell death results, whereas in other anaerobic cells after the drug has been consumed the

pyruvate cycle is capable of regenerating H<sub>2</sub> evolution.

From the work carried out previously, no clear mode of action has become apparent as many of the results published contradict each other. It may be possible that there is more than one mechanism in a given cell. The only certain known fact about nitroimidazoles is that they require reduction before they show activity.

#### Nitroimidazoles as Radiosensitisers

Nitroimidazoles have found a use as radiosensitisers in the treatment of cancer cells. The nitroimidazoles, being small molecules, are able to penetrate cells more easily than some drugs into tumour cells. Tumour cells are hypoxic (low oxygen concentrations), and nitroimidazoles selectively sensitise these cells toward radiation. Unfortunately, the more effective a sensitiser the nitroimidazole is, the more toxic it is, for example, misonidazole is a better sensitiser than metronidazole but is also more toxic.

The effectiveness of nitroimidazoles is probably connected with their action on DNA, as virtually all radiosensitisers have a mechanism involving inhibition of DNA structure and function. Reduction products arising from 2-nitroimidazoles are more stable than from 5-nitroimidazoles and it is presumably this stability difference which accounts for both the effect as a sensitiser and the toxicity because the cytotoxic reduction products can migrate to healthy normal cells more easily.

### The Market Leading Nitroimidazoles

A wide range of nitroimidazoles are in commercial production, the leading ones being: metronidazole (4), tinidazole (5), ornidazole (6), nimorazole (7), dimetridazole (8), panidazole (9), and the 2-nitroimidazole, misonidazole (10).

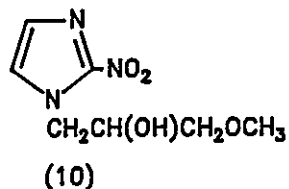
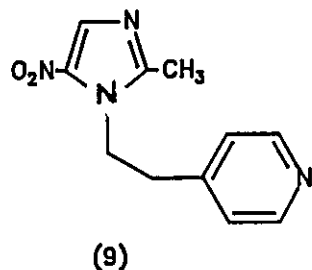
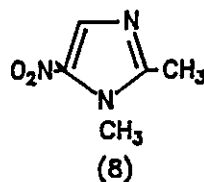
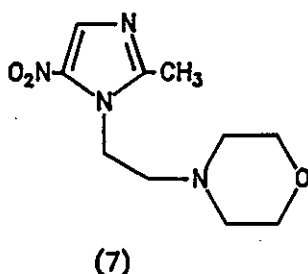
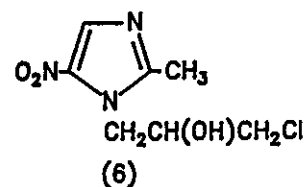
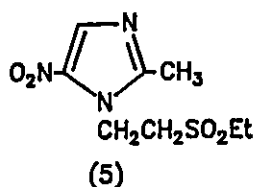
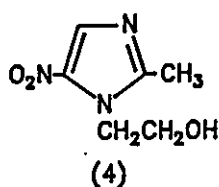

#### Metronidazole (4)<sup>23</sup>

Metronidazole was the first 5-nitroimidazole antibiotic, used first in 1960, and is still the market leader despite extensive development of analogues. It is used in the treatment of a number of diseases including amoebiasis, trichomoniasis, and giardiasis. As a result of its effectiveness, short duration of therapy, and minor toxicity, metronidazole is still the first choice drug for amoebic dysentery. During the seventies, metronidazole

found extensive use against a number of anaerobic bacterial infections such as endocarditis, osteomyelitis, lung abscess, peritonitis, septicaemia, and pelvic infections.

Although some results show that reduced metronidazole is mutagenic, (cancer causing), the degree to which this occurs indicates it is not a significant problem, particularly as mammalian cells are incapable of reducing metronidazole .

#### Tinidazole (5)<sup>23</sup>

Tinidazole was developed in an attempt to improve on the potency of metronidazole. In trials against trichomoniasis it performed with equal efficiency although against amoebiasis the clinical response of patients was slower but resulted in superior cure rates. Tinidazole also exhibited greater potency towards giardiasis than did metronidazole or nimorazole. Side effects are minor and transient from large dosages.

#### Ornidazole (6)<sup>23</sup>

Ornidazole is a particularly effective agent against trichomoniasis and has found use in the treatment of giardiasis and severe cases of hepatic amoebiasis. In certain strains of bacteria, ornidazole was found to be mutagenic although it has been demonstrated that there is no such effect on mammalian chromosomes. In comparison with metronidazole, ornidazole has a longer half-life, 13 as opposed to 8 hours.

Nimorazole (7)23

Nimorazole is primarily used as a trichomonacide and exhibits activity comparable to metronidazole. In tests against E. histolytica nimorazole proved less effective than metronidazole or ornidazole.

Dimetridazole (8)23

Dimetridazole has both therapeutic and prophylactic activity against experimentally transmitted swine dysentery. The mutation rate of K. pneumoniae and E. coli is increased by dimetridazole

Panidazole (9)23

In comparison with metronidazole, panidazole proved to be equiactive. Trials have shown that panidazole has similar pharmacological profiles to metronidazole although against vaginal trichomoniasis it proved inferior.

Misonidazole (10)23

Misonidazole is the leading 2-nitroimidazole and displays activity against T. vaginalis, T. foetus, and E. histolytica similar to metronidazole .

### Structure Activity Relationships

Of the three possible isomeric nitroimidazoles only the 2- and the 5-nitroimidazoles show considerable biological activity, and then only under anaerobic conditions. 4-Nitroimidazoles are well known but have no biological activity.

An enormous range of 2- and 5-nitroimidazoles have been prepared and tested for antimicrobial activity. All these are active but only a small number have significantly high activity against a wide range of anaerobic organisms. Some examples of the compounds with significant activity are shown below.

#### 2-nitroimidazoles

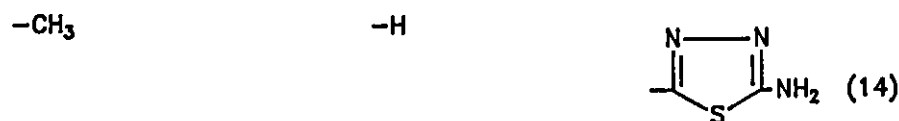
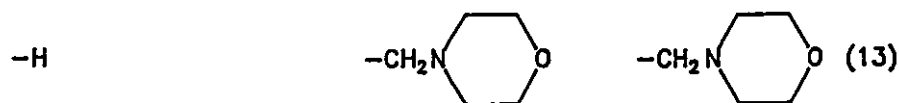
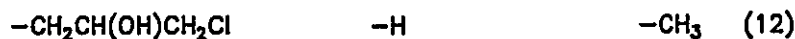
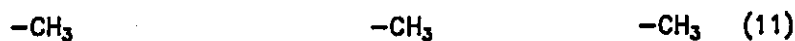
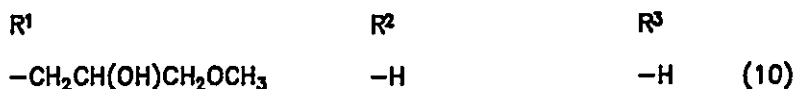
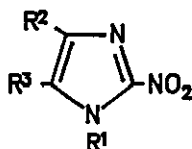

Although there have been a wide range of 5-nitroimidazoles prepared there has not been any significant improvement on the activity of the original compound, metronidazole.

5-nitroimidazoles

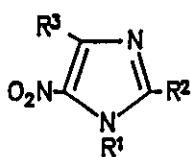
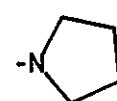
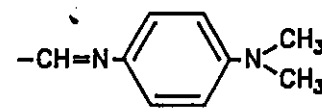
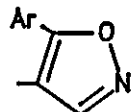
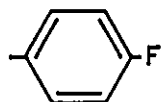
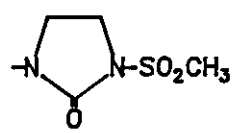
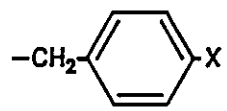
	R <sup>1</sup>	R <sup>2</sup>	R <sup>3</sup>
	-CH <sub>3</sub>	-CH <sub>3</sub>	-H (8)
	-CH <sub>2</sub> CH <sub>2</sub> OH	-CH <sub>3</sub>	-H (4)
	-CH <sub>3</sub>	-SCH <sub>3</sub>	-H (15)
	-CH <sub>3</sub>	-SO <sub>2</sub> CH <sub>3</sub>	-H (16)
	-CH <sub>3</sub>		-H (17)
	-CH <sub>3</sub>		-H (18)
	-CH <sub>3</sub>	-CH <sub>2</sub> CN	-H (19)
	-CH <sub>3</sub>		-H (20)
	-CH <sub>3</sub>		-H (21)
	-CH <sub>3</sub>		-H (22)
	-CH <sub>3</sub>		-H (23)

It is far from obvious how substituents affect the activity but clearly they do as some nitroimidazoles are more active than others.

There is a requirement for substitution other than hydrogen at the N-1 position,<sup>3</sup> usually as an alkyl group, which can prevent the rapid tautomeric exchange which is a characteristic feature of imidazole chemistry. Presumably

the reduction potential of the 4(5)-nitroimidazole is too high to allow for reduction in anaerobic cells.

As discovered during the development of tinidazole (5) and nimorazole (7), the side chain at N-1 must not sterically hinder the nitro group,<sup>3</sup> preventing the approach of the reactive site.

Substitution of the side chain with electronegative groups (i.e. -OH, -Cl, etc.) as in metronidazole (4) and ornidazole (6) enhances activity as does the presence of substituents thought to provide a radical stabilising effect, as shown by the Merck compound, flunidazole (21). The effect of polar electronegative groups may be to enhance the partition coefficient of solubilities, thereby enhancing penetration of the cell wall and membranes, rather than a chemical effect on the nitroimidazole nucleus.

Many compounds substituted at the C-2 position, such as satranidazole (22), have shown relatively high levels of activity, leading to the development of a number of compounds with the -CH<sub>2</sub>-X functional group at C-2, (where X- is aromatic heterocyclic, or aliphatic).

No clear trends have been discerned on the nature of substituents at C-2, C-4 and N-1 in 5-nitroimidazoles and C-4, C-5 and N-1 in 2-nitroimidazoles. Initial reports that C-4 substituents in 5-nitroimidazoles were not favoured have not proved to be correct, the difficulty in preparing these compounds is more likely the problem.



### MODE OF ACTION

The only clear proven part of the mode of action is the requirement that the nitroimidazole is reduced prior to any observable activity. Therefore, the reduction of nitroimidazoles is of particular importance.

Nitroimidazoles are reduced in anaerobic bacteria by ferredoxin oxireductase in the target cell to give initially the nitroradical anion (25), which itself can be reduced further to give a range of reduced species, (Equation 2).

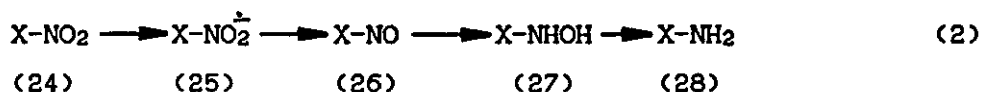
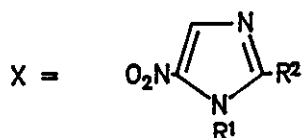

The reduction sequence is similar to that observed in other aromatic nitro-compounds, consisting of a series of single electron transfer (s.e.t.), protonation and dehydration reactions (Scheme 1).

The overall reaction can be represented by the equation



There is no clear evidence published to date as to which of the possible reduced species is the reactive intermediate in the mode of action of nitroimidazoles, although several proposals have been put forward.

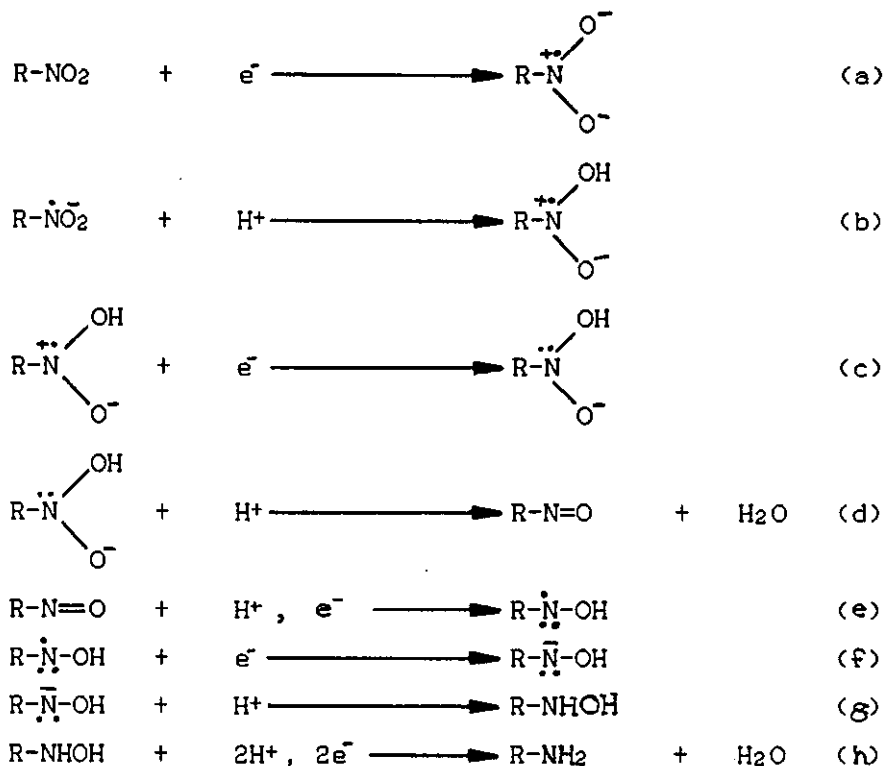

Scheme 1

#### The Amino Derivative (28)

It would appear that the amine is not the reactive intermediate in the mode of action of 5-nitroimidazoles, because the amine derivative of metronidazole (4), prepared by Sullivan *et al*<sup>24</sup>, was found to be inactive. The amino derivative of misonidazole (10) has been detected in hypoxic lung fibroblasts<sup>25</sup> and in hypoxic liver cells,<sup>26</sup> although whether it derives from the reduction (Scheme 1h), or the disproportionation (Equation 4) of the hydroxylamine, is not clear.

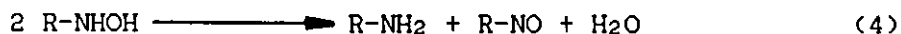

#### The Hydroxylamino Derivative (27)

Much interest has recently been shown toward the

hydroxylamino reduction of misonidazole (10). It has been reported that the hydroxylamine can rearrange<sup>27,28</sup> to give glyoxal (29) which can react with guanine<sup>29</sup> (30) or glutathione<sup>30</sup> (31) to give adducts. (Scheme 2).

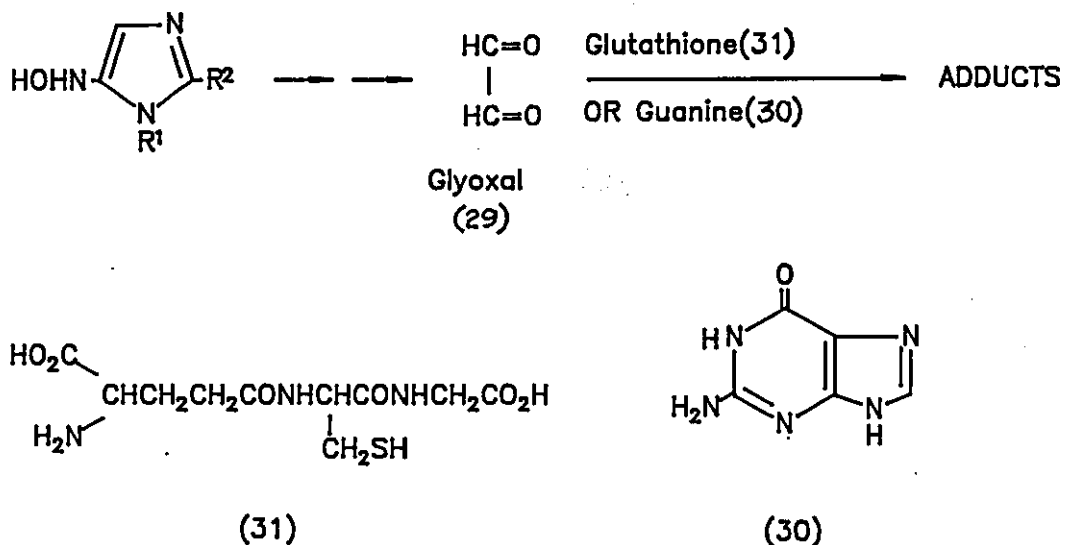

Scheme 2

This rearrangement has been shown by McClelland and co-workers<sup>31</sup> to be analogous to the Bamberger rearrangement. Such a rearrangement cannot occur for 5-nitroimidazoles, and glyoxal does not form adducts with DNA, indicating that this is not the active intermediate. Further reports indicate that the hydroxylamine, 5-hydroxylamino-1-methyl-4-phenyl imidazole, requires oxidation before becoming active.<sup>32</sup> Despite extensive research, hydroxylamine derivatives cannot definitely be assigned as the reactive species although they still remains a possibility. The hydroxylamino compounds are thought to be the degradation products of nitroimidazoles responsible for the mutagenic effects. Acetyl derivatives, of the hydroxylamino analogues of dimetridazole (32) and metronidazole (33), have proven inactive against a range of bacteria normally sensitive to nitroimidazoles, although whether the non-acetyl derivatives are active has not been investigated.

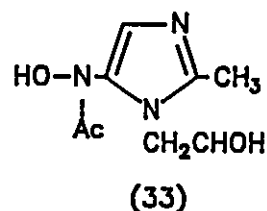
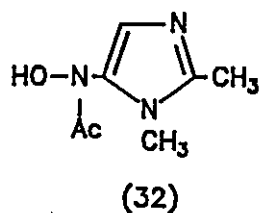

#### The Nitro Radical Anion (25)

It is well known that both electrophiles and radicals react with DNA and therefore it appears likely that the radical anion may also react due to its radical character. The radical anion is the first species in the reduction sequence produced by a s.e.t. reaction involving ferredoxin oxireductase. This step is reversible, and oxygen can accept the electron in a futile cycle to regenerate the nitro compound and give superoxide, (Equation 5).

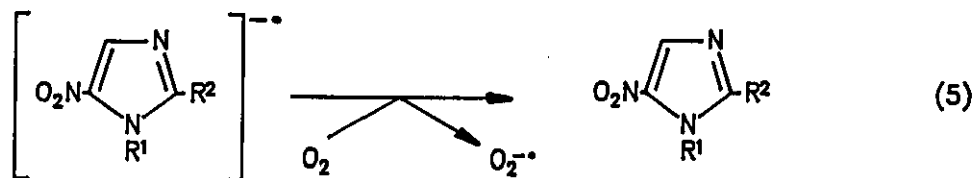

An interaction of this type could explain the lack of activity in aerobic cells and the selective toxicity toward anaerobes.

Studies using electron spin resonance (e.s.r.) spectroscopy have detected the presence of nitro radical anions in

protozoal and anaerobic bacterial cells,<sup>33</sup> suggesting that they are relatively stable and may survive long enough to react with some intracellular species. Furthermore, Bowman and Symons,<sup>34</sup> have shown that the nitro radical anion is more stable than might otherwise have been expected.

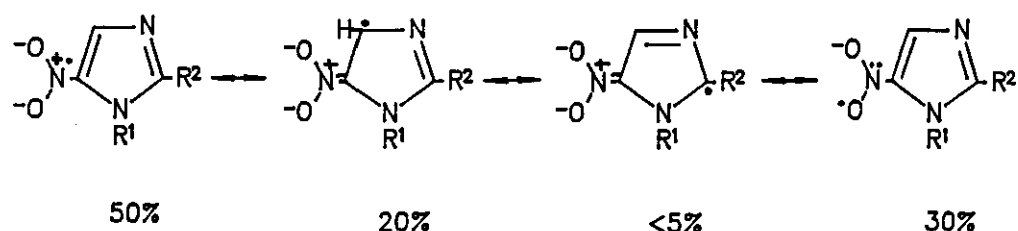

Scheme 3

Interestingly, the electron distribution in 4- and 5-nitroimidazole radical anions is almost identical,<sup>34</sup> (Scheme 3), with most of the radical character being associated with the nitro group and the C-4 or C-5 in 4-nitroimidazoles.

These observations do not explain the differences in activity between 4- and 5-nitroimidazole if the radical anion is in fact the reactive intermediate. The reactivity in this case must be wholly due to the difference in reduction potentials of the imidazoles.

Edwards *et al*<sup>13,35</sup> and Gattavecchia *et al*<sup>36</sup> have suggested a dissociation of the 5-nitro radical anion (34) to give nitrite and a 5-imidazolyl radical (35), and it is this radical which is the reactive intermediate, (Equation 6).

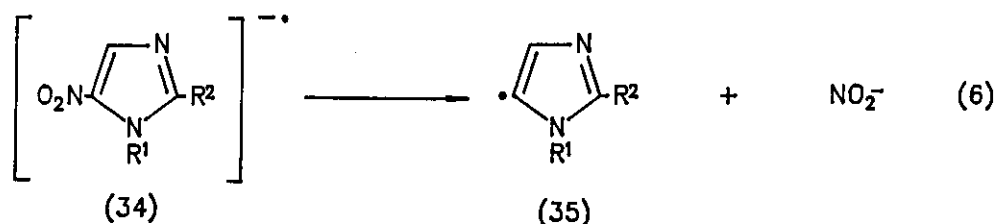

This theory is based on the observation of the release of nitrite ions (up to 30%)<sup>36-38</sup> in studies with 5-nitroimidazoles, although only very small amounts of nitrite were detected in the case of 2-nitroimidazoles. In addition, no other aromatic nitro compound is known to give a radical anion which dissociates in this manner, which perhaps suggests that this idea is unlikely.

#### The Nitroso Derivative (26)

Little work has been carried out into the possibility of a nitroso reactive intermediate, probably because it is never isolated in reduction studies. It is believed that the nitroso species is rapidly reduced to the hydroxylamino compound in reduction studies, and this reactivity has resulted in it not being seriously considered as the reactive intermediate. Studies indicating that the hydroxylamino derivative requires oxidation before becoming active,<sup>32</sup> strengthen the argument in favour of the nitroso species as the reactive intermediate as it is the immediate oxidation product.

Recently, Ehlar *et al*<sup>39</sup> have synthesised the 4- and 5-nitroso analogues, (36, 37), of 4- and 5-nitroimidazoles, (38, 39), and compared their biological activity towards a number of anaerobic micro-organisms.

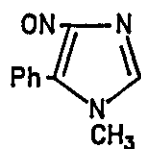

(36)

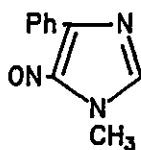

(37)

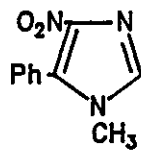

(38)

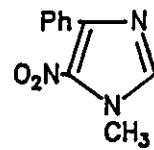

(39)

The 5-nitroimidazole, (37), was found to be between 2 and 5 times as potent as its nitro analogue, (39), despite the

rapid degradation of the nitroso compound in the bacterial culture. During the period prior to decomposition it was approximately 50 times that of (39). The 4-nitroimidazole (36), displayed comparable activity to the related 5-nitroimidazole (39), whereas the 4-nitro analogue, (38), was inactive.

These results provide further evidence for the reduction potential being the primary factor in determining the activity of nitroimidazoles, and suggest that the nitroso species is the reactive intermediate.

The only factor distinguishing 4-nitro from 5-nitroimidazoles appears to be the reduction potential, i.e. once the nitroimidazoles are reduced there is no discernible difference in reactivity.

### General Imidazole Chemistry

Imidazole is an aromatic, five membered heterocyclic molecule with two nitrogen atoms and a single carbon atom between them.

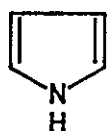

PYRROLE

(40)

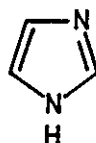

IMIDAZOLE

(41)

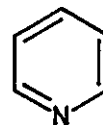

PYRIDINE

(42)

The two nitrogens in the ring are chemically different, N-1 being like that found in pyrrole whilst N-3 is pyridine-like. The two nitrogens differ in that N-3 has an available pair of electrons which can react with electrophiles, (e.g. with  $H^+$  to give salts), whereas the lone pair of N-1 is incorporated into the aromatic sextet.

The  $pK_a$  of protonation for imidazole is 6.95, similar to that of pyridine which is 5.2, whereas the  $pK_a$  for deprotonation is 14.44 as compared with 17.5 for the corresponding process in pyrrole. Imidazoles can therefore react as pyridines or as pyrroles depending on the conditions employed. As might be expected, ring substituents can affect the basicity of the doubly bonded nitrogen as follows:

- (a) Methyl substituents increase the basicity due to their mesomeric and inductive electron donor effect, (+I).
- (b) Phenyl groups reduce the basicity because though they are weak resonance donors, they are inductive acceptors, (-I).



- (c) Amino groups are base strengthening, due to their strong mesomeric donating ability, particularly when directly conjugated with the basic centre, (+M, -I).
- (e) Halogens cause a marked decrease in basicity, especially when in  $\alpha$ -positions, because of their inductive acceptor nature, (+M, -I).
- (f) the  $pK_a$  values are almost unaffected by fused benzene rings.
- (g) Nitro substituents exert a base-weakening effect due to their inductive acceptor properties, (strong -I, -M).

### Electrophilic Substitution

Electrophilic attack can occur at N-3 or any of the carbon atoms. In imidazole, C-2 and C-4 are like the deactivated  $\alpha$ -positions in pyridine (42), the C-5 is like the  $\beta$ -position. As a result, imidazole lies between pyridine and benzene in reactivity towards electrophiles, and is much less reactive than pyrrole (40).

In the case of nitration, the order of reactivity is pyridine > imidazole > benzene. Nitration of imidazole is carried out by a mixture of concentrated nitric and sulphuric acids at 160°C and proceeds by attack of the protonated species (43) by  $\text{NO}_2^+$  to give the doubly charged intermediate (44), (Equation 7).

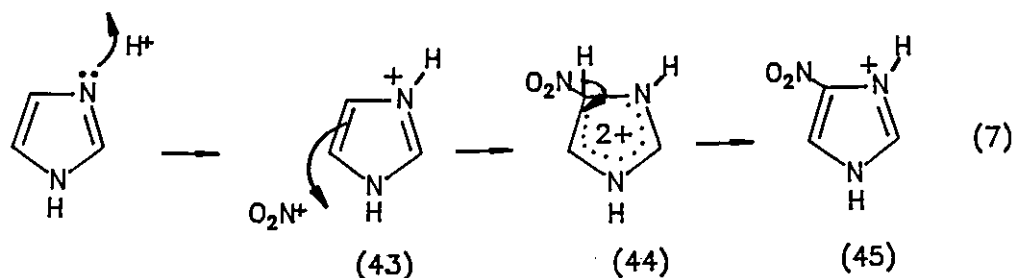

The intermediate (44) deprotonates to give the protonated nitroimidazole (45), which is a mixture of two tautomeric forms (46, ~~47~~), (Equation 8).

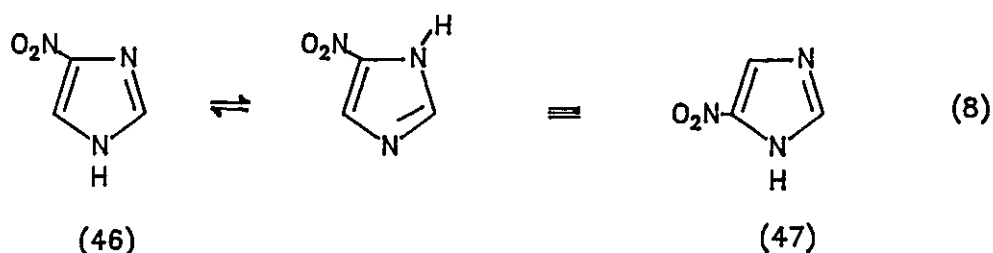

### Tautomerism

Imidazole is subject to rapid interconversion between two tautomeric forms, (Equation 9).

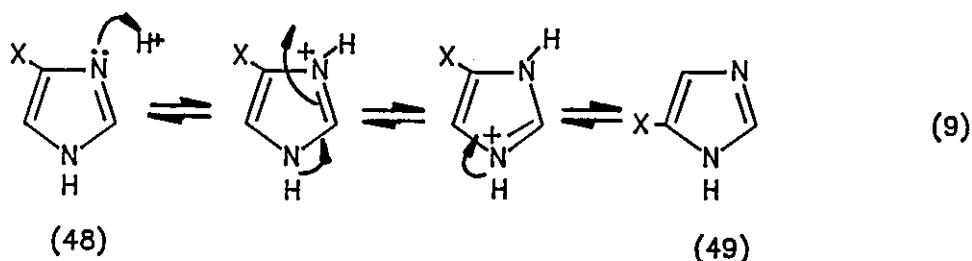

When there are no ring substituents, the two tautomers are identical, but if substituents are present at C-4/C-5 they are non-equivalent. In these cases, the nature of the substituent determines the proportion of the two tautomers, (Equation 9). If the substituent is  $-\text{NO}_2$ , (electron withdrawing), a base weakening effect is exerted on N-3 making protonation less favourable. In the C-4 tautomer (48), the base-weakening is more pronounced than in the C-5 tautomer (49) because the substituent is adjacent to the N-3 position. As the tautomerism is acid catalysed, (i.e. requires protonation), the resulting difference in basic strength shifts the tautomeric equilibrium toward the 4-tautomer because N-3 in the 5-tautomer protonates more

readily, (Equations 10 and 11).

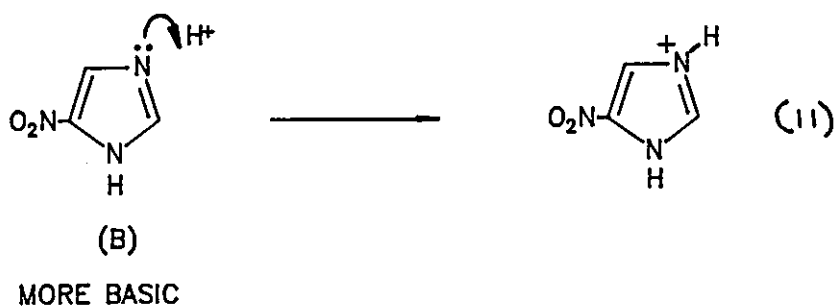
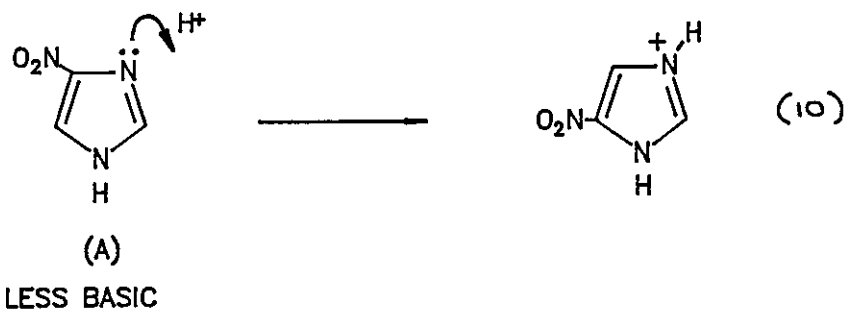

Isomer (A) is favoured in tautomerism.

As a result, 4-nitroimidazole exists with 5-nitroimidazole in a ratio of 400:1. When one tautomer is preferred, it is denoted by writing the minor ring site in brackets, [e.g. 4(5)-nitroimidazole].

#### Isomerism

N-Alkylation of imidazoles substituted at the 4- or 5-positions gives rise to the formation of isolable isomers, possessing different physical and chemical properties.

The ratio of isomers depends on the reaction conditions employed as can be seen in the case of methylation of

nitroimidazoles,<sup>40</sup> (Scheme 4).

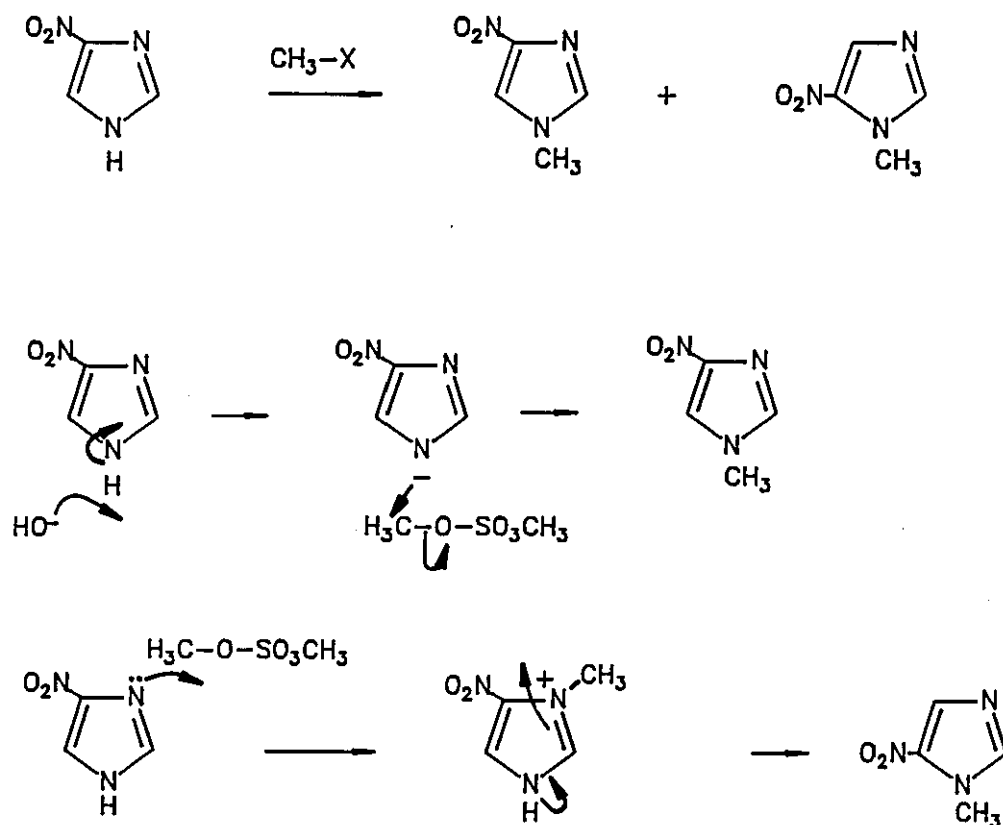

Scheme 4

At high pH values imidazole acts as the conjugate base, (Scheme 4), and reaction occurs at the more reactive anionic N-1 site. However, under neutral conditions, attack occurs at the more basic pyridine-like N-3. By carefully selecting the reaction conditions the desired isomer can be prepared.

#### Nucleophilic Displacements at C-2<sup>23</sup>

A useful synthetic methodology often found in the preparation of nitroimidazole antibiotics is the displacement of a sulphonyl group, (-SO<sub>2</sub>Me), from the C-2

position by some nucleophilic species. The  $S_NAr$  reaction parallels the  $S_NAr$  activity of 2-substituted pyridines, (Equation 12).

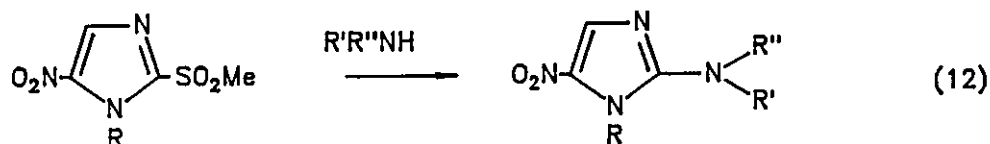

A wide range of amino derivatives have been successfully prepared using this methodology.

#### Ring Synthesis<sup>40</sup>

If the desired imidazole cannot be prepared by a substitution reaction on the ring, it must be made by synthesising the whole ring. Numerous approaches to imidazole ring synthesis have been successfully employed, depending on the substitution pattern required. Some of these approaches can be generalised as shown below:

(a) C-C + N-C-N; e.g.  $\alpha$ -Haloketones (50), when heated together with amidines (51), give imidazoles, (Equation 13).

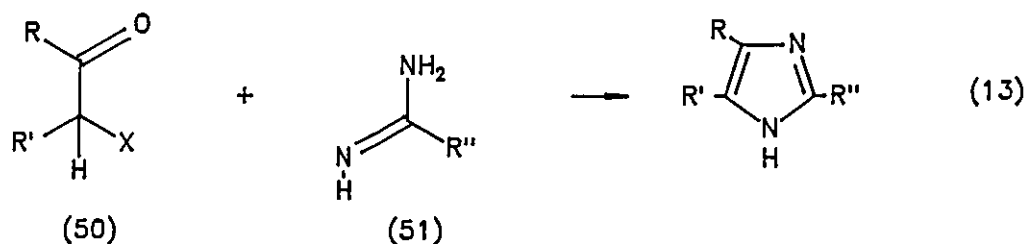

(b) C-C-N-C + N; e.g.  $\alpha$ -Acylamino ketones (52), give imidazoles when heated with ammonium acetate. This method is particularly suited to the synthesis of

2,4,5-triarylimidazoles, (Equation 14).

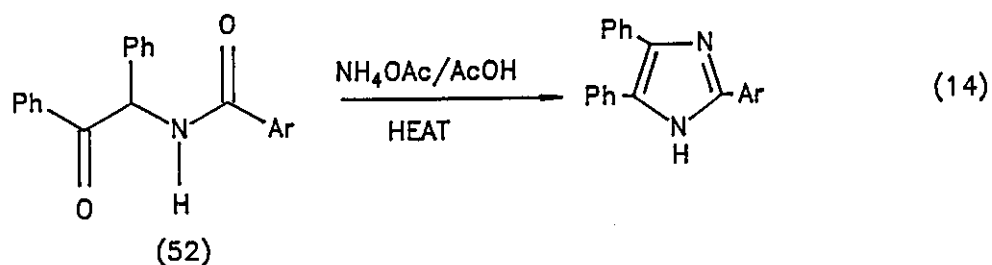

(c) Cyclisations of C-C-N-C-N fragments; e.g.  $\alpha$ -Acylamino Schiff's bases (53) give 1-substituted imidazoles when cyclised by treatment with phosphoryl chloride, (Equation 15).

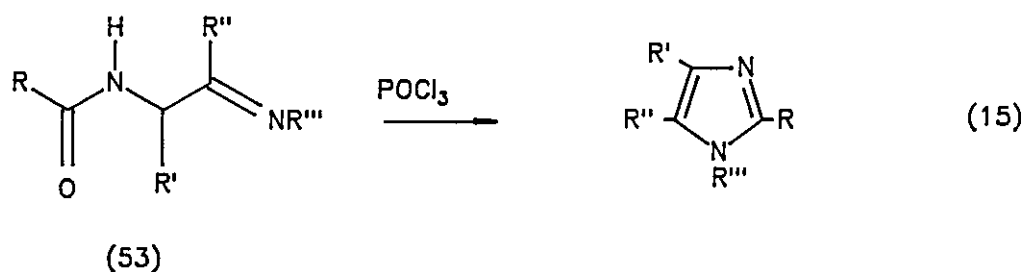

(d) 1,3-Dipolar addition to give C-C; e.g. Treatment of the precursor (54), with sodium ethoxide in DMF gives the imidazole (55), (Equation 16)

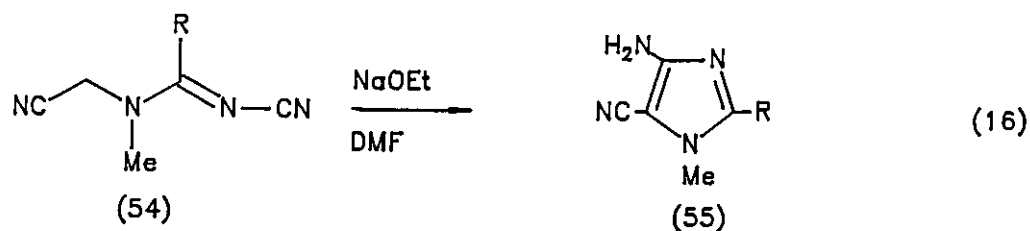

(e) Synthesis from other heterocycles; There are two main synthetic approaches from other heterocycles,

(i) from the facile ring opening of aziridines (56) by sodium iodide to give imidazolines (57) which can then be converted into the appropriate imidazole, (Equation 17).

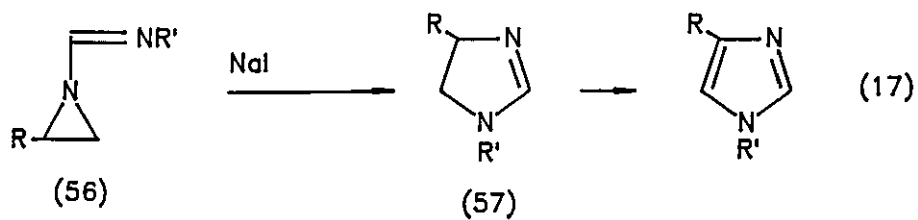

(ii) from rearrangements, such as in the photoisomerisation of pyrazoles, or the exchange of heteroatom, as in the case of oxazoles (58) and oxazole-4-carboxylic acids, (Equation 18).

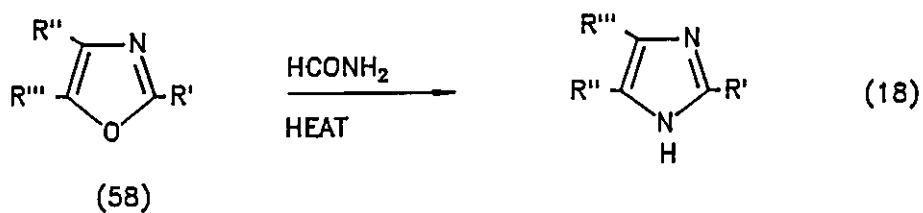

## RESULTS AND DISCUSSION

### INTRODUCTION

The study of nitroimidazole antibiotics has in the past centred on the biological effects and has avoided examination of the chemical mechanisms involved.

It is known that nitroimidazoles require reduction before becoming active. In the cell this reduction is achieved by single electron transfer (s.e.t.) from ferredoxin oxireductase, (a hydrogenosomal enzyme), to give initially the radical anion (59). Subsequent reduction can occur to give a range of reduction products, as is the case for other aromatic nitro compounds, resulting in the primary amine (60), (Equation 19).

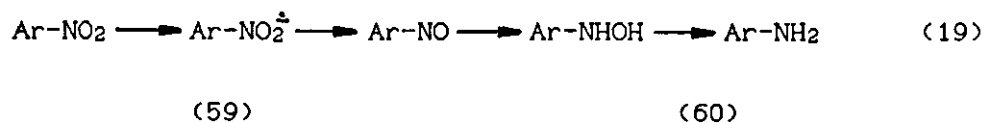
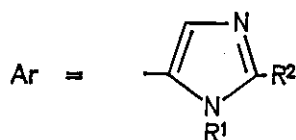

Although there are several possible sites of attack in the cell, (e.g. energy cycle, repair mechanisms, etc.), the most likely is thought to be DNA, (Figure 2).

Research into nitroimidazoles has shown that they cause extensive DNA strand breakage which kills the cell. It is believed that the reduced nitroimidazole interacts with the DNA, possibly by the formation of a covalent adduct, and interferes with the replication of DNA. However, no adducts have been isolated to date to indicate which reduced species is responsible for the activity.



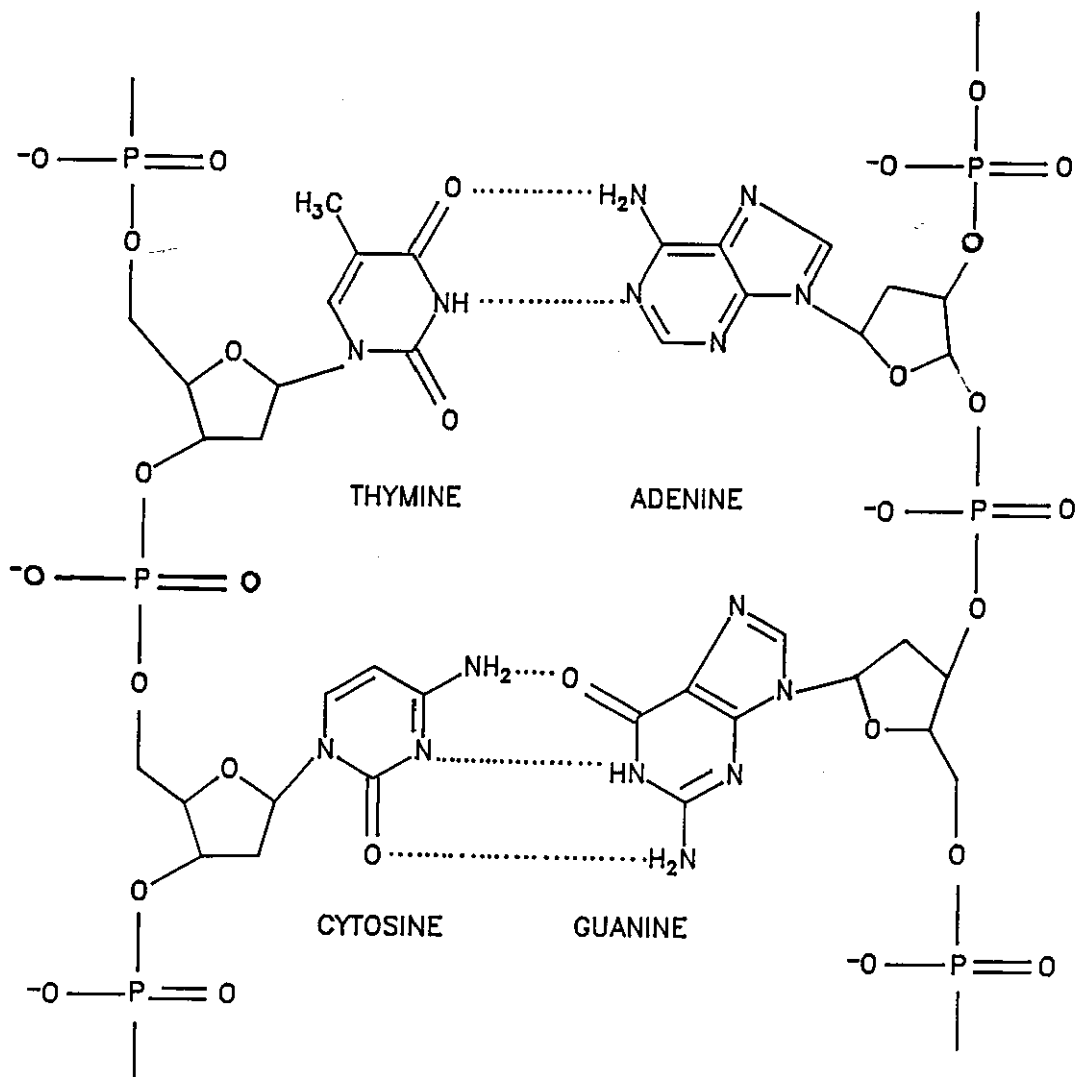

Figure 2

DNA is a nucleophilic molecule and it is known that reaction with electrophilic species and radicals is possible. It would appear therefore that the reactive intermediate involved is likely to be electrophilic or radical in nature. Some of the possible reactions are as follows:

- (a) DNA and the nitro radical anion (a nucleophile but also a radical)
- (b) DNA and the imidazol-5-yl radical, from the dissociation of the radical anion

- (c) DNA and the nitroso species
- (d) DNA and the nitroso radical anion
- (e) DNA and the hydroxylamino species
- (f) DNA and the amino species.

This research project has concerned itself with (a) to (d), because in the case of (e) and (f), hydroxylamine and amine derivatives were found to require an oxidation step before displaying activity and consequently appear unlikely candidates.

The results discussed in this thesis are arranged into sections in the following order:

- Section 1 - Radical anions of nitroimidazole as putative reactive intermediates in the mechanism of action
- Section 2 - Putative dissociation of the nitro radical anion
- Section 3 - Nitrosoimidazoles : possible intermediates in the mechanism of action of nitroimidazole antibiotics

## SECTION 1 RADICAL ANIONS OF NITROIMIDAZOLES AS PUTATIVE

### INTERMEDIATES IN THE MECHANISM OF ACTION

#### 1.1 PREPARATION OF REQUIRED NITROIMIDAZOLES

Various nitroimidazoles were prepared for studies in this section for two reasons. The first was to examine the radical anions of nitroimidazoles with different ring substituents by e.s.r. spectroscopy to determine whether the electronic nature of the substituent had any effect on the electron distribution (unpaired electron in the radical anion, (Scheme 5).

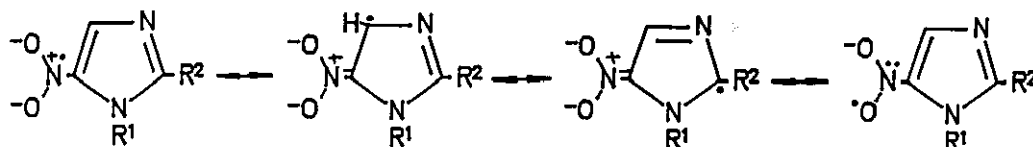

Scheme 5

If the radical anion is the reactive intermediate, one would expect activity to be related to the electron distribution of the radical (unpaired electron) across the molecule. By studying the effect of ring substituents on the e.s.r. spectra one should therefore expect to see differences in electron distribution which may correlate with differences in antibacterial activity.

There appeared to be a correlation between radical stabilising groups and high antimicrobial activity, (i.e. low M.I.C.), e.g. a 2-vinyl-5-nitroimidazole is particularly active. Dialkylamino groups are known to strongly stabilise free radicals, and nitroimidazoles with amino substituents

at C-2, e.g. satranidazole, give particularly interesting activity.

Therefore, we sought to obtain or prepare a range of 1-methyl-5-nitroimidazoles to test this hypothesis. The groups chosen were 2-Me<sup>41</sup> (+I), 4-Me<sup>42</sup> (+I), 4-NH<sub>2</sub><sup>43</sup> (-I,+M), 2-H<sup>42</sup> (no effect), 2-SMe<sup>44</sup> (-I,+M), 2-pyrrolidino<sup>44</sup> (-I,+M), and 2-SO<sub>2</sub>Me<sup>44</sup> (-I), because syntheses were known in the literature.

Satranidazole<sup>45</sup> (22) was obtained from the Boots Company (India).

The second group of nitroimidazoles to be synthesised were N-alkenyl compounds, for the study of possible intramolecular cyclisation reactions.

The descriptions of the syntheses of the chosen compounds are detailed below.

(a) Preparation of nitroimidazoles substituted at C-2

The simplest example of a nitroimidazole substituted at C-2 is 1,2-dimethyl-5-nitroimidazole (8), which is a commercially produced drug under the name of dimetridazole.

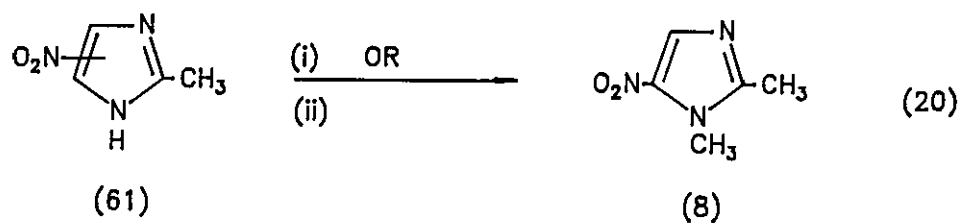

(i) CH<sub>2</sub>N<sub>2</sub>/Et<sub>2</sub>O/18h

(ii) CH<sub>3</sub>OTs/120 °C/4h

It was prepared by treatment of 2-methyl-4(5)-nitroimidazole (61) with diazomethane or with methyl *p*-toluenesulphonate,

both of which gave the required compound in moderate yield, (Equation 20).

The mechanism for the methyl *p*-toluenesulphonate reaction which is shown in Equation 21, involves S<sub>N</sub>2 attack by the lone pair (on N-3) on the methyl group of the methyl *p*-toluenesulphonate followed by elimination of the N-1 proton to give the desired 5-isomer (8).

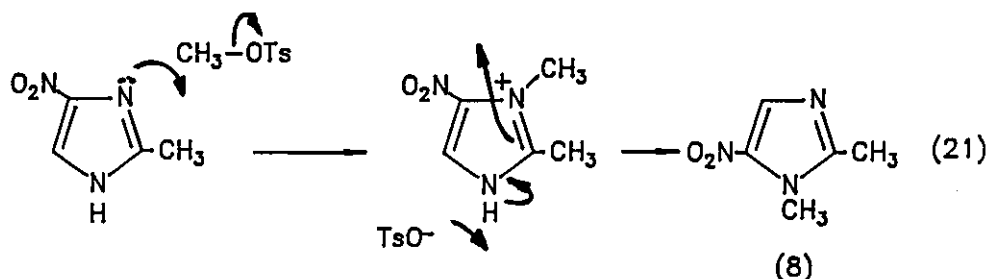

It has been suggested that methylation by diazomethane proceeds via the transition state shown below. It is probably the neutral nitroimidazole which attacks protonated diazomethane that explains why substitution gives predominantly the 5-nitro product. If the anion of the nitroimidazole was the attacking species, then the 4-nitro product would be expected.

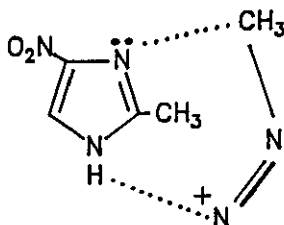

The mechanism initially involves the abstraction of a proton by diazomethane followed by attack of the methyl group by the lone pair on N-3 in the ring, resulting in the elimination of nitrogen gas. Aromaticity is restored by loss of the N-1 proton, (Scheme 6).

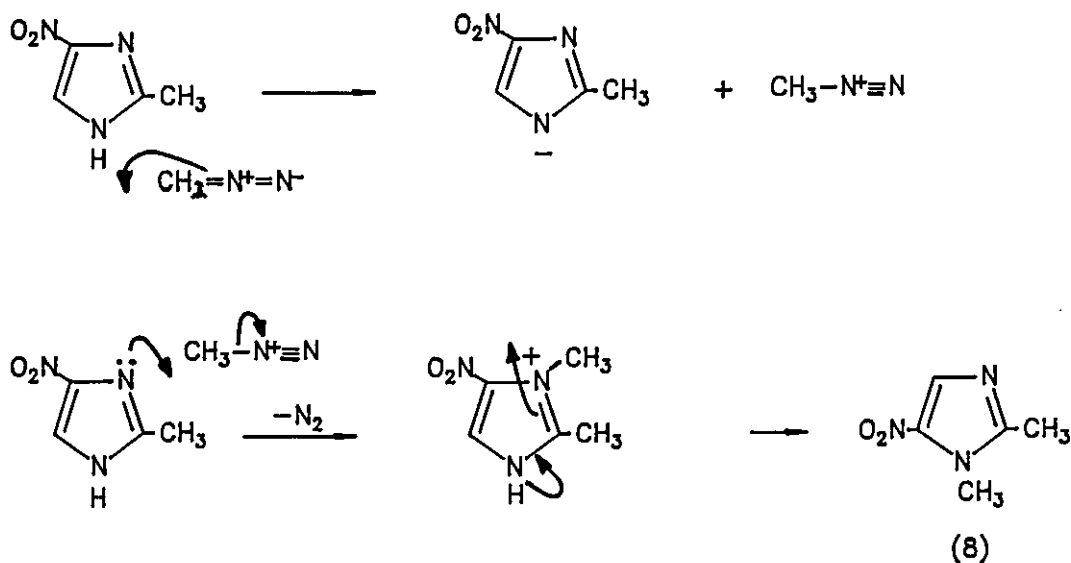

Scheme 6

Both of these methods proved useful synthetically. The MeOTs route being less complicated and more reliable in the long run because of the quality of the diazomethane, which we prepared from the action of alcoholic KOH on the amide (62), was inconsistent, (Equation 22).

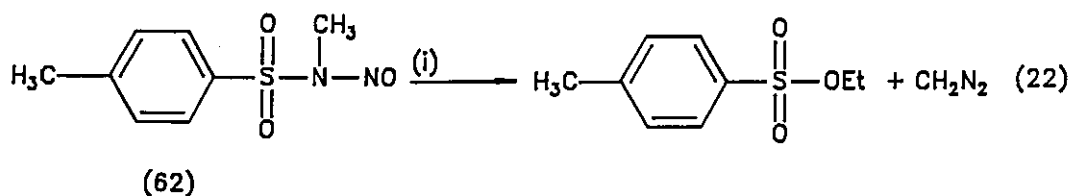

(i) KOH/EtOH/H<sub>2</sub>O/60 °C

When the methylation with MeOTs was attempted using toluene as a solvent none of the required material was obtained. We believe that the boiling temperature of toluene, 110°C, was insufficient to facilitate reaction. In addition, the melt reaction normally employed allows a more intimate contact between the reactants, (i.e. higher concentration), giving

an increased rate of reaction.

Other substituents with electron releasing or withdrawing properties were introduced into the ring system by functionalisation of an existing ring or by whole ring synthesis.

Methylmercapto (15) and methylsulphonyl (16) derivatives were prepared from 2-methylmercapto-1-methylimidazole (64) by nitration with  $\text{HNO}_3$  to give (15), (Equation 23).

Subsequent oxidation with monopero-phthalic acid gave the sulphone (16) in moderate yield. The nitration can be performed on the N-methyl compound due to the S-methyl group directing attack entirely at the 5-position and activating the ring towards electrophilic attack. Both compounds, (15) and (16), were highly crystalline and were ultimately purified by recrystallisation, whereas the intermediate (64) was a liquid which we did not attempt to purify but used directly in the next stage of the synthesis.

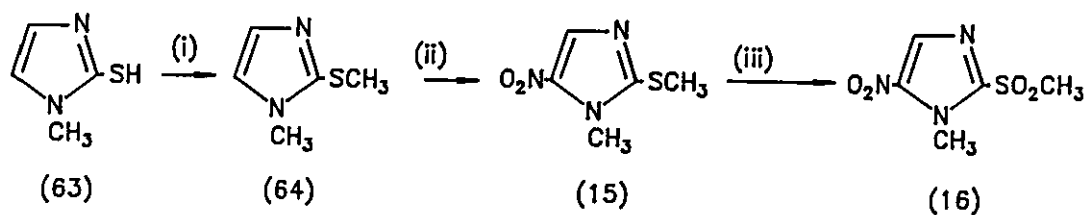

(i) BASE/Mel

(ii)  $\text{HNO}_3$

(iii) MPPA

(23)

Satranidazole (22), a commercially produced drug, is prepared from the sulphonyl derivative (16) by  $\text{S}_{\text{N}}\text{Ar}$  substitution,<sup>45</sup> (Equation 24). A sample of satranidazole was provided by the Boots Company plc (India) for use in

e.s.r. spectroscopic studies.

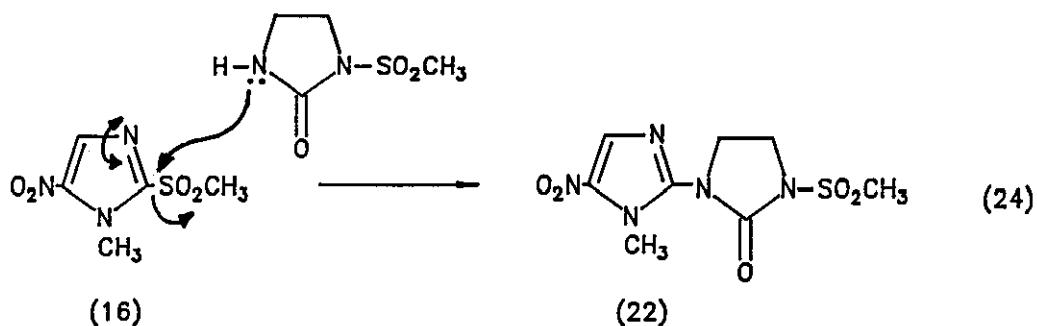

1-Methyl-2-pyrrolidino-5-nitroimidazole (17)<sup>45</sup> with an electron releasing pyrrolidinyl group at the 2-position was prepared from methyl isothiocyanate (65) and pyrrolidine (66) as shown in Scheme 7.

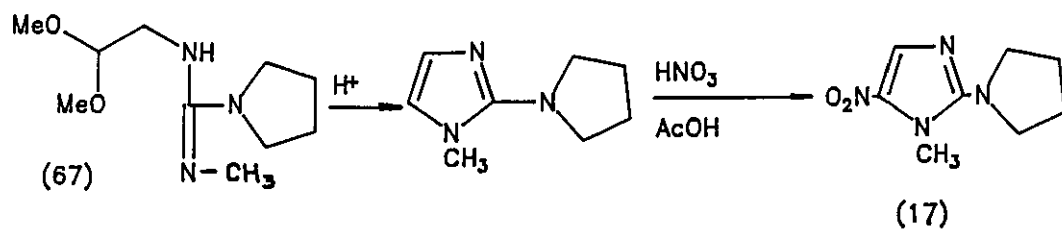
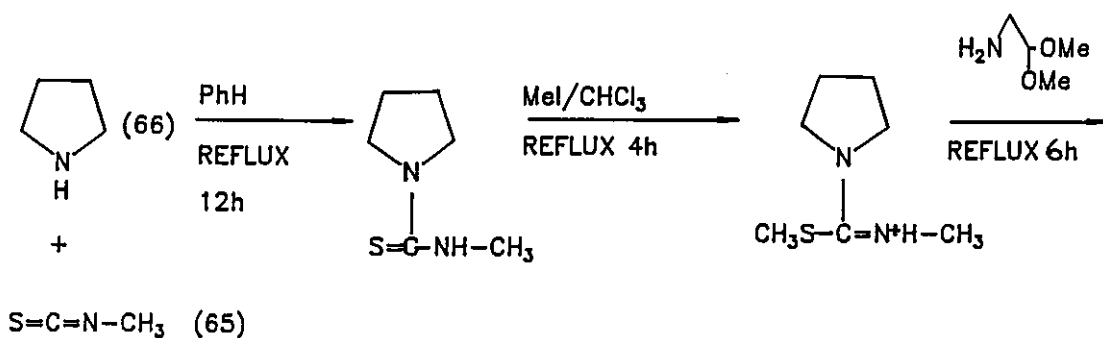

Scheme 7

No yield is given for the intermediate (67) because it was not isolated. All steps in the synthesis were high yielding except the final nitration reaction, (8%), which by mistake was allowed to react for a longer period of time



than was recommended.<sup>46</sup> The particularly low yield is probably attributable to oxidation of the imidazole ring leading to its decomposition when exposed to the nitration conditions for long periods of time. The actual nitration is probably rapid because the pyrrolidinyl substituent will activate the ring towards electrophilic substitution in the same way as the 2-SMe derivative.

(b) Preparation of 4-substituted nitroimidazoles

Previously it had been reported<sup>3</sup> that 5-nitroimidazoles, substituted at the 4-position, were not very active, but this is probably due to the difficulty in synthesising them. There is little data in the literature pertaining to the antimicrobial activity of 4-substituted nitroimidazoles. We prepared a number of nitroimidazoles with combination of methyl and nitro groups in 4- and 5- positions (68-70)<sup>47</sup>.

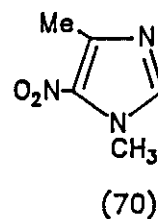
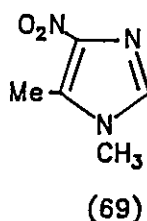
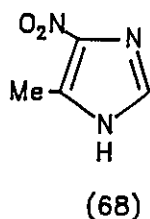

4(5)-Methylimidazole (71) was nitrated with conc. HNO<sub>3</sub>/conc. H<sub>2</sub>SO<sub>4</sub> to give (68). Methylation of 5(4)-methyl-4(5)-nitroimidazole (68) with dimethyl sulphate in basic conditions gave predominantly 1,5-dimethyl-4-nitroimidazole (69) together with some 1,4-dimethyl-5-nitroimidazole (70), (Equation 25).

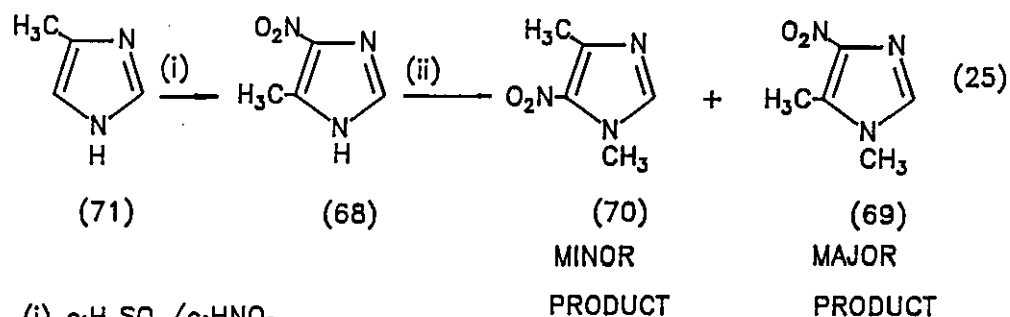

(i)  $\text{c}\cdot\text{H}_2\text{SO}_4/\text{c}\cdot\text{HNO}_3$

(ii)  $(\text{CH}_3\text{O})_2\text{SO}_2/\text{OH}^-$

The compounds were separated using a combination of column chromatography and fractional recrystallisation. Both isomers were observed to discolour on standing, whether on the bench or in the freezer, over a few days. 1,4-Dimethyl-5-nitroimidazole (70) was prepared by methylation with methyl *p*-toluenesulphonate. A small quantity of 1,5-dimethyl-4-nitroimidazole (69) was also produced but was separated as already indicated. 1-Methyl-4-nitro- (72) and 1-methyl-5-nitroimidazole (73) were synthesised in a similar fashion from 4(5)-nitroimidazole (46), (Equation 26).

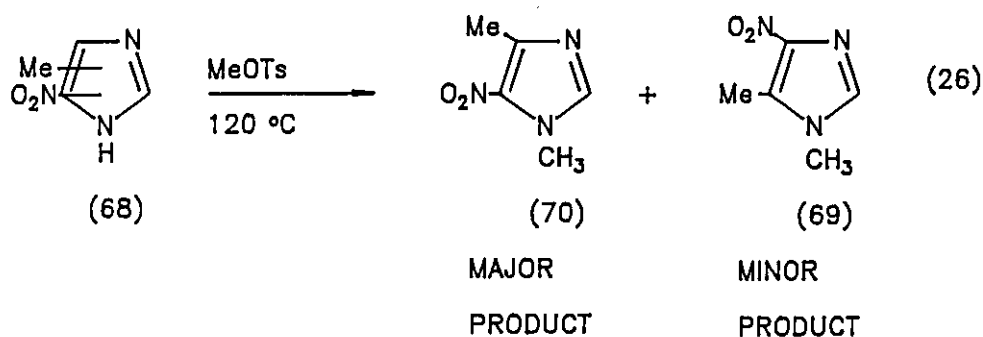

Much lower quantities of the minor isomers were produced than in the case of the dimethyl nitroimidazoles and therefore these required little or no separation by comparison. The reason for this difference in selectivity is probably due to the effect of the methyl at C-4/-5 which will decrease the basicity of N-3 and increase the acidity of N-1 by virtue of its +I nature. Such a change will alter

the balance of the free base tautomerism toward 4(5)-methyl-5(4)-nitroimidazole (74).

We attempted to prepare 4-amino-1,2-dimethyl-5-nitroimidazole (75) from 1,2-dimethyl-5-nitroimidazole (8) as described in the literature,<sup>43</sup> by treatment with hydroxylamine hydrochloride and base in ethanol solution, (Scheme 8). Repeated attempts gave none of the expected compound and only unreacted starting materials. We believe that extraneous water was the reason for our lack of success, but even when rigorously dried equipment and solvents were used, no product was obtained.

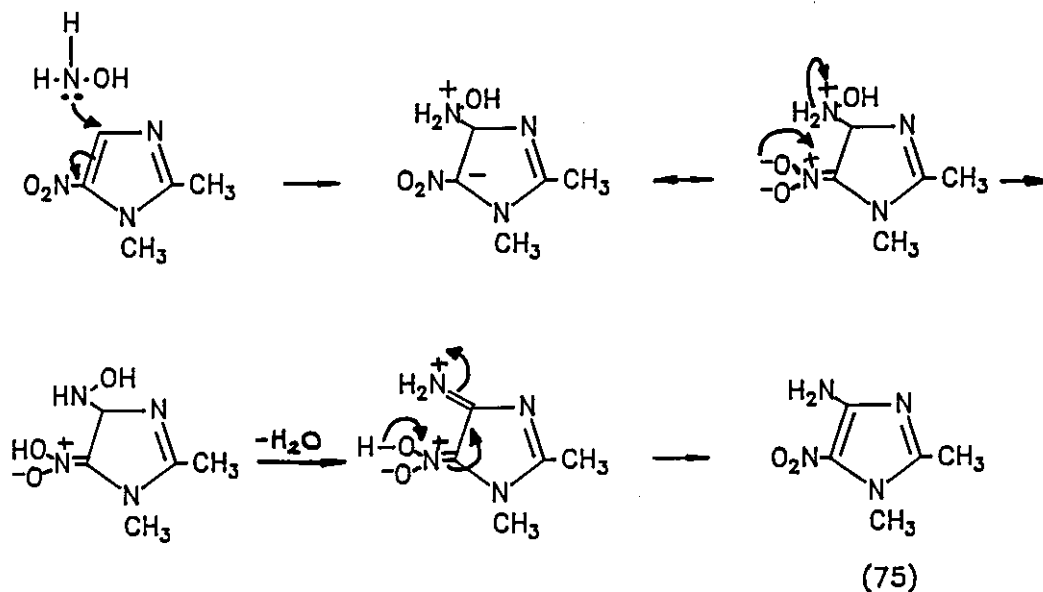

Scheme 8

It was intended that the amine and the dialkyl derivatives (76) be used in e.s.r. spectroscopic studies as examples of nitroimidazoles with -I, +M substituents in the 4-position.

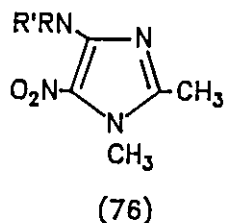

c) Preparation of 1-alkenyl substituted nitroimidazoles

In addition to the e.s.r. spectroscopic analysis of the nitroimidazoles already described, we planned to trap the radical anions generated by single electron reduction of nitroimidazoles by intra- and inter-molecular means. The intramolecular route would probably be more favourable in terms of kinetic considerations due to the unimolecular nature of the reaction. The simplest trapping species suitable for trapping radicals is an unsaturated bond and therefore we planned to incorporate such a functional group into a nitroimidazole as a side chain with various numbers of  $-\text{CH}_2-$  units between the ring and the terminal double bond.

Two 5-nitroimidazoles with alkenyl side chains at the 1-position (77) and (78) were prepared from 2-methyl-4(5)-nitroimidazole by treatment with the alkenyl *p*-toluene-sulphonates (79) and (80) respectively, (Equation 27).

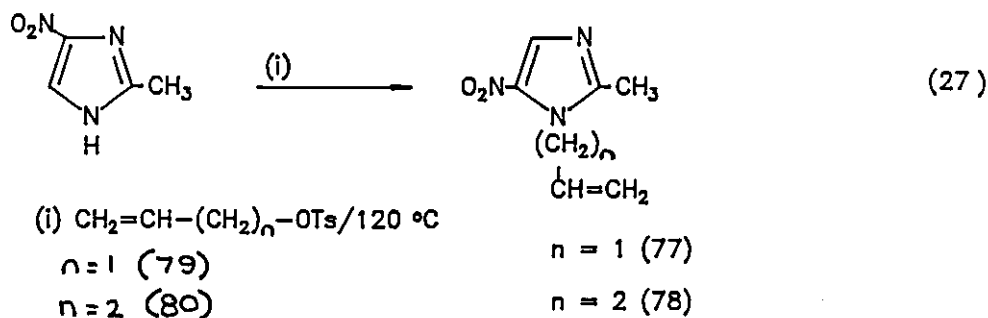

1-Allyl-2-methyl-5-nitroimidazole (77) was prepared as reported in the literature,<sup>48</sup> in low yield (~ 25%). The compound was isolated as an oil which resisted attempts to crystallise it. We believed that the compound was impure and tried unsuccessfully to purify it using column chromatography and derivatisation as the hydrochloride salt. The hydrochloride salt was highly hygroscopic and could not be crystallised effectively. The regenerated free base, an

oil, solidified on cooling but became liquid at or around room temperature. Distillation was not attempted as we believed that the compound was too unstable.

The 1-(3-buten-1-yl) compound (78), is novel and was produced in even lower yields (~12%) than the allyl compound. The compound was obtained as a crystalline solid after purification as the hydrochloride salt obtained followed by rebasification. Preparation of 1-(3-buten-2-yl)-5-nitroimidazole has been reported<sup>49</sup> with yields of less than 10%.

As with the methylations using MeOTs, attempts to alkylate with alkenyl tosylates using toluene as solvent proved unsuccessful, probably for the same reasons as previously discussed.

The tosylates were prepared in a different way to that of the normal solvolysis method in pyridine. In the case of allylic alcohols, the displaced chloride from *p*-toluenesulphonyl chloride attacks the newly formed tosylate displacing the tosyl group and giving the allylic chloride via a S<sub>N</sub>2 mechanism. Therefore 25% aqueous NaOH solution was used instead of pyridine as a base, and 2 equivalents of the alcohol were used. This method gave high yields for both of the alkenyl tosylates tried (~80% with respect to the *p*-toluenesulphonyl chloride), (Scheme 9).

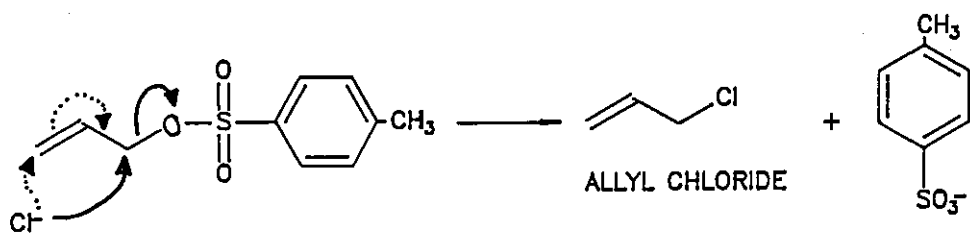
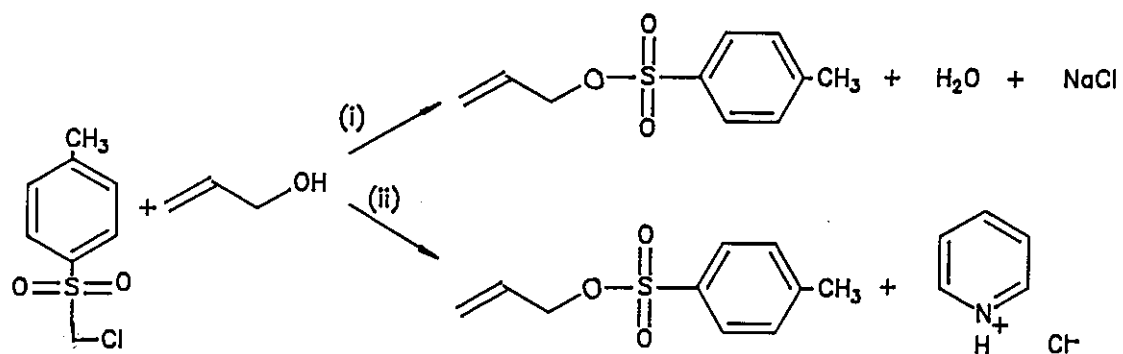

Scheme 9

- (i) NaOH  
 (ii) Pyridine.

## 1.2 ELECTRON SPIN RESONANCE (E.S.R.) SPECTROSCOPIC STUDIES

This thesis does not include an interpretation of the e.s.r. spectroscopy but uses the interpretations and conclusions drawn by Professor Martyn C.R.Symons. The results obtained are shown in Table 1 and are shown for reference only.

IMIDAZOLE	SUBSTITUENTS		COMPOUND	SOLVENT	NUCLEUS	A/G <sub>a</sub>			
						A <sub>n</sub>	A <sub>1</sub>	A <sub>iso</sub>	
5-NO <sub>2</sub>	1-Me	2-Me	(8)	CD <sub>3</sub> OD or MeTHF	<sup>14</sup> N	31	8	15.7	
5-NO <sub>2</sub>	1-Me	2-CH <sub>2</sub> Cl <sub>b</sub>	(81)	CD <sub>3</sub> OD	<sup>14</sup> N <sup>35</sup> Cl	31.5	9	16.5	
				MeTHF	<sup>14</sup> N <sup>35</sup> Cl	30.5 0 ± 3	d		
5-NO <sub>2</sub>	1-Me	2-CH <sub>2</sub> Br <sub>b</sub>	(82)	CD <sub>3</sub> OD	<sup>14</sup> N <sup>81</sup> Br	31 19	d		
5-NO <sub>2</sub>	1-Me	2-CH <sub>2</sub> OH <sub>b</sub>	(83)	CD <sub>3</sub> OD	<sup>14</sup> N	31.5	8	16.2	
					<sup>1</sup> H	5			
				MeTHF	<sup>14</sup> N <sup>1</sup> H	31 5	d		
5-NO <sub>2</sub>	1-Me	2-CH <sub>2</sub> N <sup>+</sup> Me <sub>3</sub> <sub>b</sub>	(84)	CD <sub>3</sub> OD	<sup>14</sup> N	32	9	16.7	
					<sup>1</sup> H	5			
				MeTHF	<sup>14</sup> N <sup>1</sup> H	31 5	d		
5-NO <sub>2</sub>	1-Me	2-SMe	(15)		<sup>14</sup> N	32	~7		
					<sup>1</sup> H	~6			
5-NO <sub>2</sub>	1-Me	2-pyrrolidinyI	(17)		<sup>14</sup> N		31	~7	
					<sup>1</sup> H	~5			
5-NO <sub>2</sub>	1-Me	2-SO <sub>2</sub> Me	(16)		<sup>14</sup> N	30	~5		
					<sup>1</sup> H	~6			
5-NO <sub>2</sub>	1-CH <sub>2</sub> CH <sub>2</sub> OH	2-Me <sub>b</sub>	(14)	CD <sub>3</sub> OD	<sup>14</sup> N	32	7.5	15.7	
					<sup>1</sup> H	5			
5-NO <sub>2</sub>	1-Me	4-Me	(70)		<sup>14</sup> N	33	~5		
	1-Me	4-NO <sub>2</sub>	2-Me	(85)	CD <sub>3</sub> OD	<sup>14</sup> N	32	8	16
					MeTHF	<sup>14</sup> N	31	8	15.7
	1-H end	1-Me	2-NO <sub>2</sub>	(86,87)	CD <sub>3</sub> OD and MeTHF	<sup>14</sup> N	25	9	14.3

Table 1: The e.s.r. spectra of some substituted nitroimidazoles

NB:  $A_{N_{\parallel}}$  parallel hyperfine coupling constant (in Gauss)

$A_{N_{\perp}}$  perpendicular

$A_{iso}$  isotropic

-I refers to negative inductive effect

+I " " positive " " "

+M " " " mesomeric "

$a$  1G =  $10^{-4}$  T : G = Gauss; T = Tesla;  $b$  Reference<sup>34</sup>

Previous studies of simple alkyl substituted nitroimidazoles<sup>34</sup> have demonstrated the similarity between the radical anions of 4- and 5-nitroimidazoles in terms of the distribution of the radical across the ring, (Figure 3).

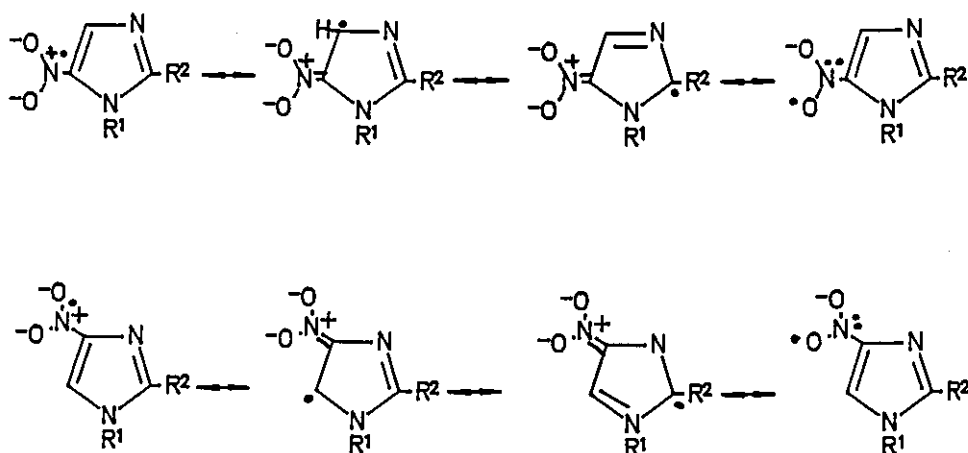
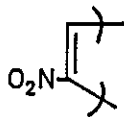

Figure 3

In excess of 95% of the radical character is centred on the nitroalkenyl portion, (see below), which includes the C-4 and C-5 atoms, [ca 50% on the nitro N-atom, ca 20% on C-4 (5-NO<sub>2</sub>)N C-5 (4-NO<sub>2</sub>), and presumably ca 30% on the nitro O-



atoms].34



The canonical forms representing simple 1,2-dialkylated-5-nitroimidazoles are also shown in Figure 3, indicating that radical stabilising groups at C-2 and C-4 should have some effect, and that the effect at C-4 would be predicted to be more significant than at C-2.

We expected that the inclusion of radical stabilising/destabilising groups around the imidazole ring would have greater effect on the electron distribution in the radical anion. However, as can be seen from Table 1, the observed effects of a number of different substituents is minimal.

The introduction of +I groups at the 4-position would be expected to alter the electron distribution in the radical anion significantly, but as can be seen from the results in Table 2., the inclusion of a methyl substituent in the 4-position has no effect. However, other groups such as NMe<sub>2</sub>, Ph or vinyl, may exhibit significant effects.

From the e.s.r. spectra run so far, it would appear that the inclusion of radical stabilising groups around the ring has little effect on the electron distribution of nitroimidazole radical anions. We know that nitroimidazoles with different substituents display a range of biological activities but, according to the e.s.r. spectroscopic data, the radical anions of different 5-nitroimidazoles are essentially identical. In addition, the radical anions of 4-nitroimidazoles are also very similar to those of the analogous 5-nitroimidazoles. This similarity in electron distribution cannot explain the activity differences within

a series of 5-nitroimidazoles nor can it explain the very low levels of activity observed in 4-nitroimidazoles. What is clear is that if the nitro radical anion is the reactive species in the mode of action, it is due solely to the specific electronic structure of the (-CH=C-NO<sub>2</sub>-) portion of the molecule.

The e.s.r. results do not preclude the nitro radical anion from being the reactive intermediate. The lack of activity of 4-nitroimidazoles can be explained by their much higher reduction potential which prevents the initial reduction step in anaerobic cells. Similarly, the range of biological activities displayed by 5-nitroimidazoles could be solely determined by the partition coefficients which govern transport across cell membranes. If this were in fact the case, ring substituents could be viewed as aids to deliver the active radical to the site of reaction.

Whilst being of interest, we still do not understand the underlying reaction mechanisms involved in the mode of action, the identity of the reactive site within the cell, or whether the nitro radical anion is the reactive drug intermediate.

### 1.3 REDUCTION REACTIONS OF NITROIMIDAZOLES

In order to understand the reactivity and to gain evidence that the nitroimidazole radical anion is possibly the active intermediate in the mode of action of nitroimidazole antibiotics, we decided to undertake reduction studies in which the radical anion would be trapped inter- and intramolecularly.

#### Putative intramolecular trapping of nitroimidazole radical anions

So far as we are aware, there are no literature reports of the trapping of nitro radical anions, and therefore, the exact nature of the species resulting from trapping is unclear, although in the case of the nitroimidazole radical anion, a number of possible cyclisation routes may be postulated. Different canonical forms have been used to illustrate possible intramolecular trapping of the radical anion. Other speculative routes could be proposed and other N-side chains could have been used, e.g.  $(\text{CH}_2)_n\text{CH}=\text{NO}_2^-$ . The hope was that products could be isolated and identified that would indicate trapping of the radical anion.

Of the possible products resulting from cyclisation in Scheme 10, the nitron (88) appears to be possible. Cyclisations leading to seven membered intermediates are less favourable. Structure (89) and (90) resulting from cyclisation at C-2 would also seem less likely because from our e.s.r. spectroscopic evidence less than 5% of the radical character is centred on C-2. No consequence of reaction at C-4 is given because it involves a highly sterically unfavourable linkage across the imidazole ring. Any, and all, of these structures are likely to be quite unstable and may react further to give any number of decomposition products. It may be the case that cyclisation is taking place but the resulting species are too short

lived to be isolable. What is clear is that all of the starting material is consumed quickly to give a wide variety of minor products.

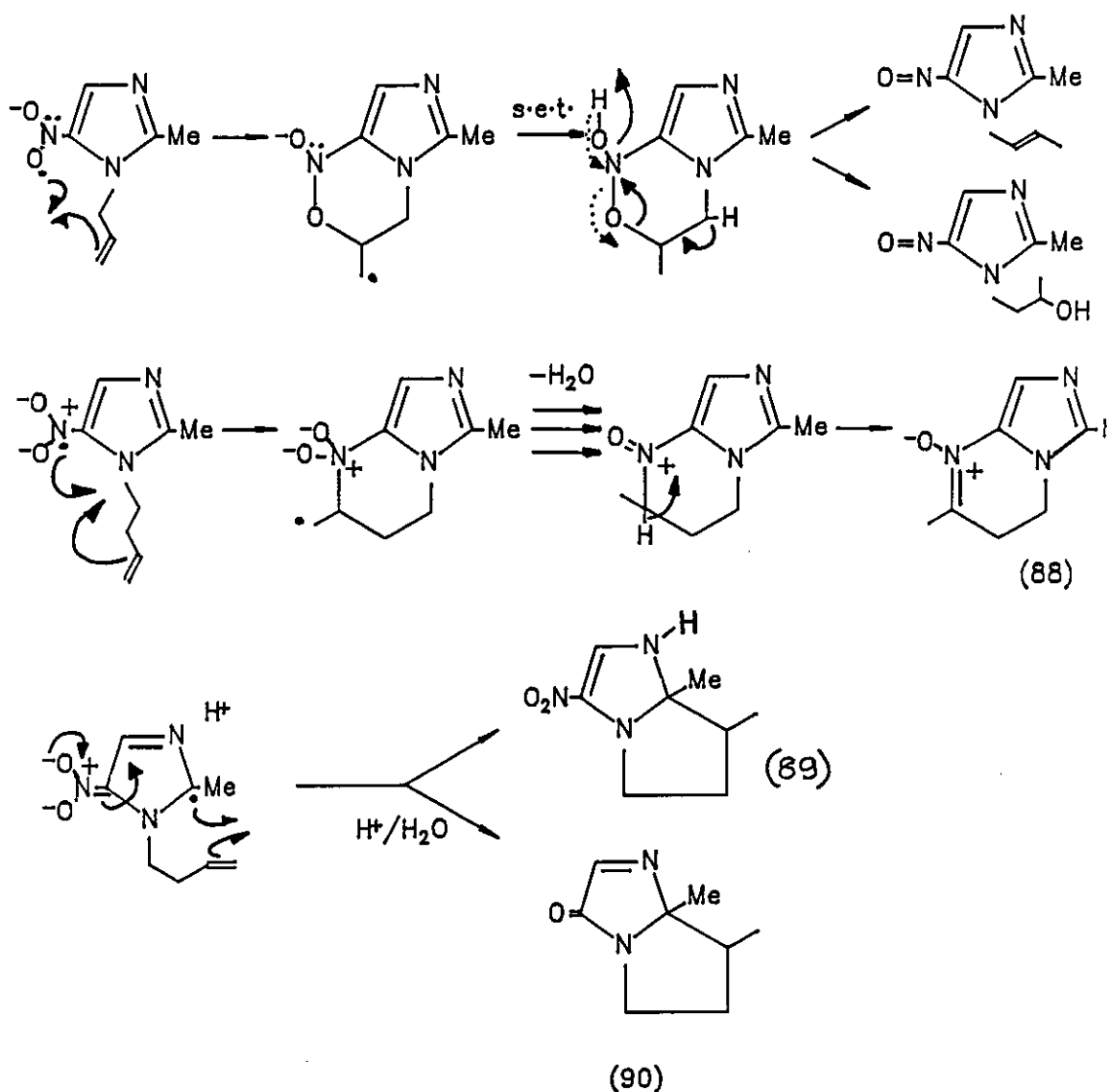

Scheme 10

Putative internal reaction between nitroimidazole radical anions and nucleosides

An important precedent in the literature<sup>50</sup> suggests that the radical anions of nitroimidazoles can be trapped intermolecularly. Crozet and co-workers<sup>50</sup> have used the anion of 2-nitropropane to reduce 1,2-dimethyl-5-nitroimidazole to

its radical anion and to trap it once reduced, (Scheme 11). The anion of 2-nitropropane is more nucleophilic than the hetero-rings of nucleosides but possibly provides a guide to potential reactions. Although interaction between the radical anions of nitroimidazoles and nucleosides proposed is a long shot, we thought that it deserved some initial studies.

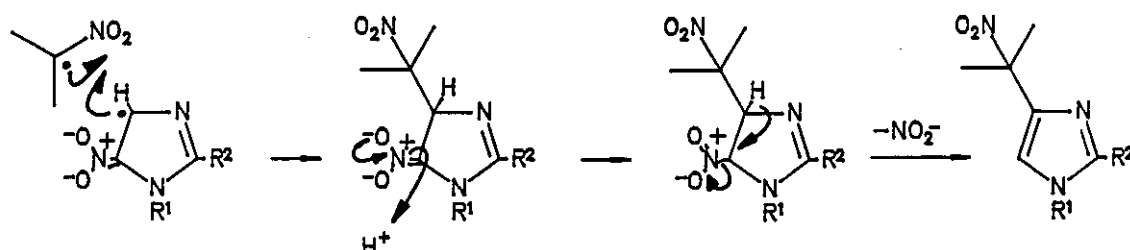

Scheme 11

A number of reductive conditions were employed including  $\text{Bu}_3\text{SnH}$ , liquid  $\text{NH}_3/\text{Na}$ , sodium dithionite/ $\text{H}_2\text{O}$ , and electrochemical reduction. Intramolecular trapping studies were carried out on 1-(3-buten-1-yl)-2-methyl-5-nitroimidazole (78) whilst the intermolecular reactions were performed using 1,2-dimethyl-5-nitroimidazole (8).

(a) Reductions using Aqueous Sodium Dithionite

Sodium dithionite has been used to reduce nitroimidazoles prior to biological testing under aqueous conditions at various pH's. Edwards<sup>5</sup> and LaRusso<sup>8</sup> demonstrated that metronidazole (4) causes DNA strand damage to calf thymus DNA when reduced with aqueous sodium dithionite under anaerobic conditions.

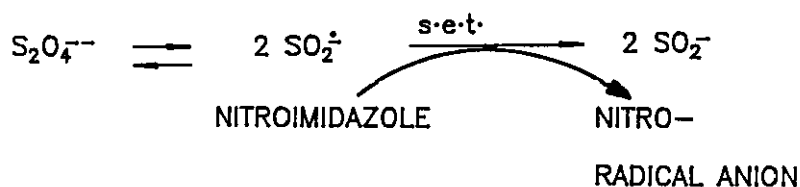

Scheme 12

Such work suggests that aqueous sodium dithionite is a suitable reductive system for radical trapping reaction, (Scheme 12).

The addition of 1-(3-buten-1-yl)-2-methyl-5-nitroimidazole (78) to sodium dithionite in aqueous  $K_2HPO_2/KH_4PO_4$  buffer resulted in a virtually instantaneous colour change from colourless to yellow which probably indicates the onset of reduction and possibly the formation of the radical anion (Equation 26).



Reactions were run for 30 min to 3 h at pH values of 7.5, 8.5, and 9.5. In all cases when analysed by t.l.c., the reaction product mixtures were found to consist of many highly coloured compounds which were inseparable. Such compounds are probably the result of polymerisation, and of the azo, azoxy and other reduction products which are produced during the reduction of aromatic nitro compounds. An alternative explanation reported in the literature<sup>4</sup>, is that one of the coloured compounds may have a similar structure to the 5,5-di-imidazole-4-one (91) which resulted from the exposure to air of reduced 4(5)-nitroimidazole. At no time did we detect any cyclised species which would result from the intramolecular cyclisation onto the radical anion.

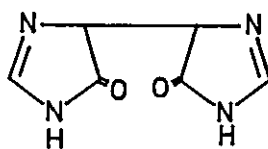

(91)

Reductions of 1,2-dimethyl-5-nitroimidazole (8) in the presence of thymine (92) using dithionite as a reductant were carried out in an attempt to intermolecularly trap the radical anion. Thymine was chosen as a model for a possible

DNA site of reaction in anaerobic microorganisms. A possible interaction between the radical anion and thymine (92)/thymidine (93) is shown below (Scheme 13). This mechanism could explain the formation of nitrite observed in biological studies.<sup>13,35-37</sup> We stress that this mechanism is purely speculative.

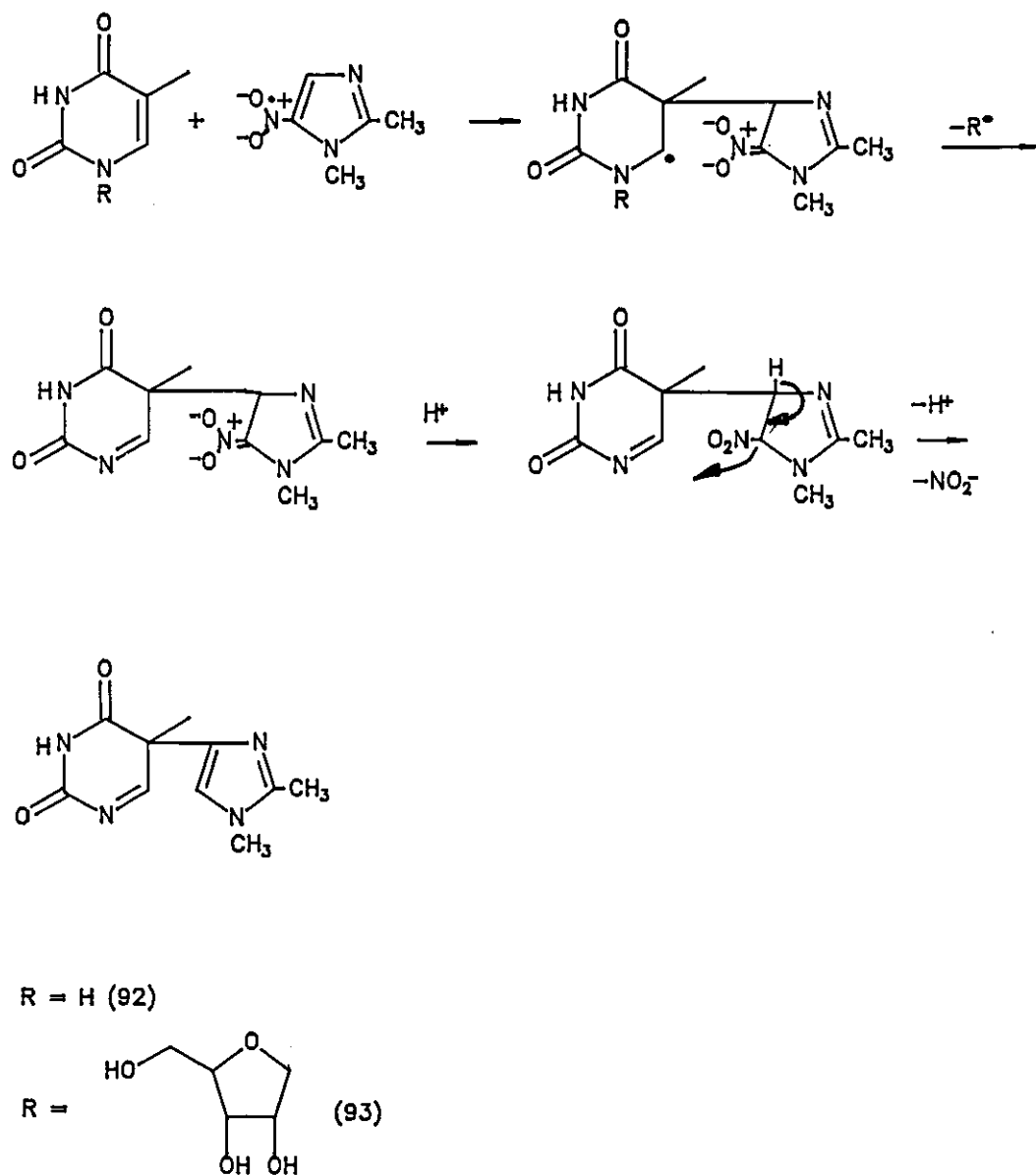

Scheme 13

All attempts to trap the radical anion with thymine were

unsuccessful even when high dilution conditions were employed to prevent reaction between two radical anions. (Equation 29)



Recovered thymine and similar coloured products as found in the intramolecular studies indicate that under these specific reduction conditions, reduced 5-nitroimidazole radical anions cannot easily be trapped and that reactions resulting in extensive decomposition occur preferentially to interaction with thymine or with internal sites. Such trapping would appear to be either thermodynamically or kinetically unfavourable.

(b) Electrochemical Reduction of 5-nitroimidazoles

Many biological studies have been performed on nitroimidazoles using electrochemical reduction to generate reduced drug species and to study their subsequent effects on DNA. The methods reported in the literature 4,5,16,51-55 usually employ a fixed potential which is delivered via a dropping mercury pool cathode system. Aqueous sodium citrate buffer is the most common medium used in literature reactions, although this is often supplemented with low concentrations of EDTA, presumably to complex certain unwanted metal ions. Unfortunately, the experimental conditions cited in the literature were somewhat ambiguous, so we consulted Dr. P. Mitchell of the Electrochemistry Section at Loughborough, about a suitable apparatus and methodology.

The electrochemical studies were carried out with the assistance of Dr. P. Mitchell of the Department of Chemistry at Loughborough University in the electrochemistry laboratories. For our electrochemical studies, we used a



specially designed cell. (Figure 4). 0.1 M NaCl aqueous buffer, a lead cathode, and a platinum foil anode were used.

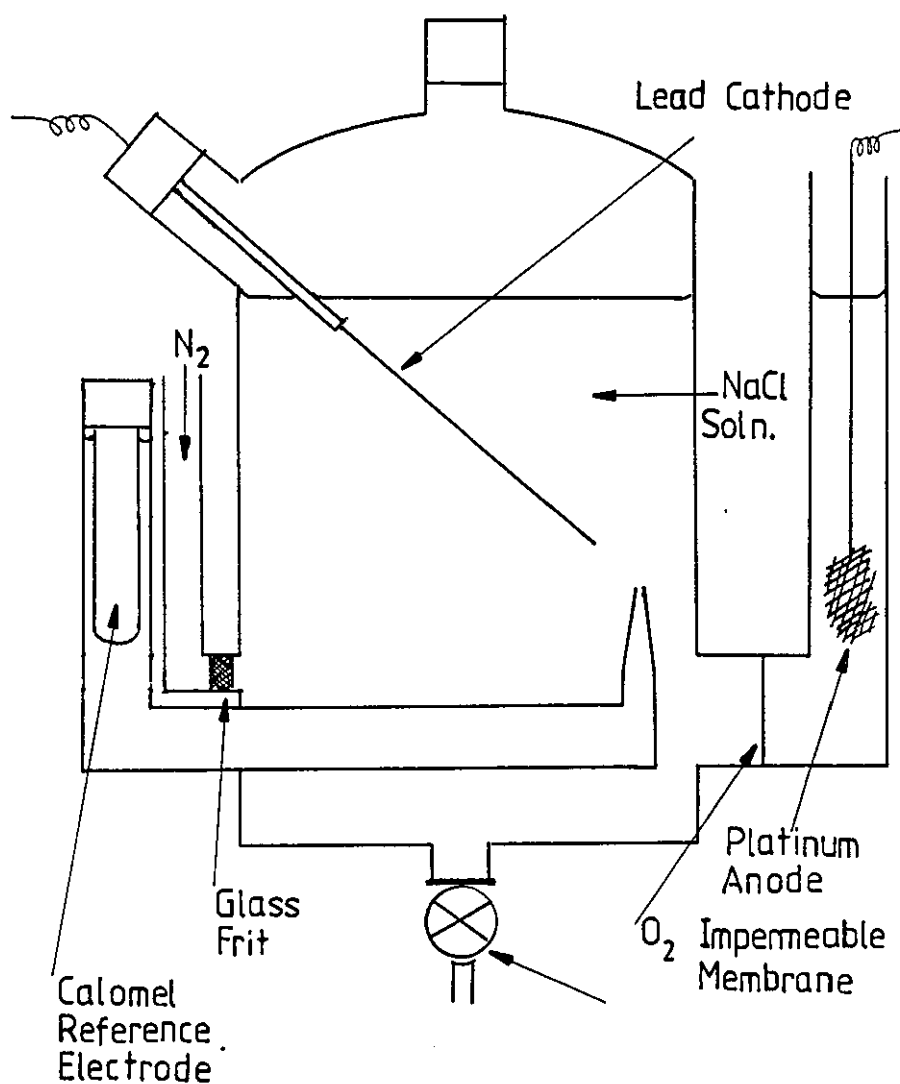

Figure 4

The optimum reduction potential was determined by scanning a cell containing buffer solution only to ascertain whether any interference from buffer/electrode reactions occurred. It was found that the useable potential window for our system was between -800 mV and -1000 mV (with respect to saturated sodium calomel reference electrode). At potentials more negative than -1000 mV, reduction of PbCl<sub>2</sub> (formed by the reaction between buffer and cathode) was observed and

above -1400 mV, H<sub>2</sub> was evolved. All reactions were carried out at a constant potential of 800 mV, (Equation 29a).



Reactions involved the reduction of 1,2-dimethyl-5-nitroimidazole (8) in the presence of thymine(92), thymidine (97) cysteine (94), cytosine (95), adenine (96), and guanosine (97) at potentials between -680 and -800 mV. Blank runs were performed to ensure that the compounds listed did not react at the same potentials employed.

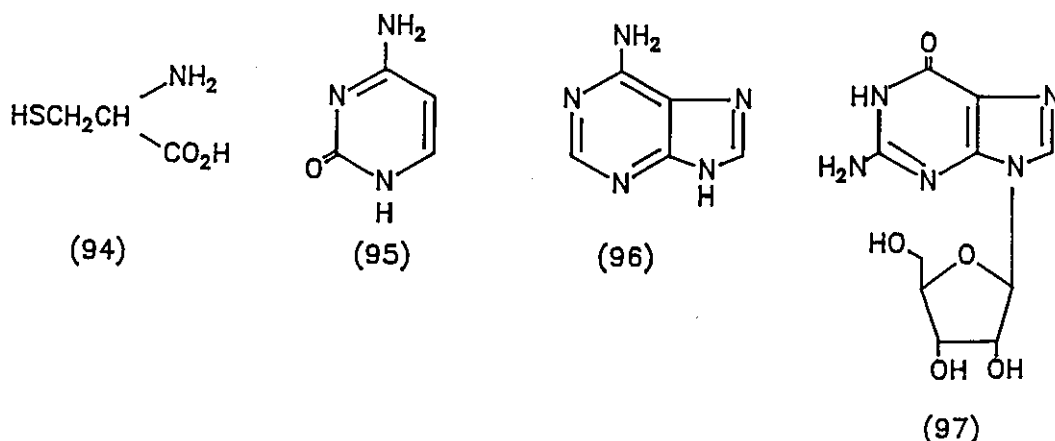

In each case the addition of the nitroimidazole resulted in a yellow-coloured reaction solution which increased in intensity during the reaction. Also associated with the addition was an instantaneous rise in current indicating that some chemical reaction was occurring. During the reactions, the current decreased and the reactions were stopped when no further decrease was evident (i.e. essentially zero current). The progress of the reactions was monitored by u.v. spectroscopy of aliquots run against 0.1 M NaCl aqueous buffer solution. In all cases examined, the u.v. absorptions corresponding to the trapping agents remained unchanged whereas the nitroimidazole absorptions gradually declined as the reaction progresses toward

completion. Work-up consisted of extraction with organic solvent. The organic extracts contained traces of residual trapping agents and similar multicoloured breakdown products as found in the dithionite reductions.

The reactions were complicated by the low solubilities of all the reagents in the aqueous buffer that was required, and of the trapping agents in organic solvents.

Clearly, the conditions employed were reducing the nitroimidazole but no reaction with the nucleoside bases was evident. This may have been due to the relatively low concentrations used or because the nitro radical anion, or some other reduction product, does not react in the proposed manner with the trapping agents chosen. Alternative acrylic type radical traps were not tried because of solubility problems in aqueous solutions required in electrochemistry.

Intermolecular trapping reactions with 1-allyl-2-methyl-5-nitroimidazole (77) and 1-(3-buten-1-yl)-2-methyl-5-nitroimidazole (78) were also attempted, but also resulted in the familiar mixture of coloured decomposition products as found in the dithionite reactions. At no time was any trace of cyclised material resulting from the intramolecular trapping of the nitro radical anion observed.

(c) Bu<sub>3</sub>SnH reduction of 5-nitroimidazoles

These reactions, unlike those previously discussed, were carried out in non-aqueous conditions. Tri-n-butylin hydride (Bu<sub>3</sub>SnH) is a commonly used source of radicals in organic chemistry. When photolysed in the presence of a radical initiator, such as azobisisobutyronitrile (AIBN), in hydrophobic solution, Bu<sub>3</sub>SnH gives Bu<sub>3</sub>Sn• radicals (Scheme 14).

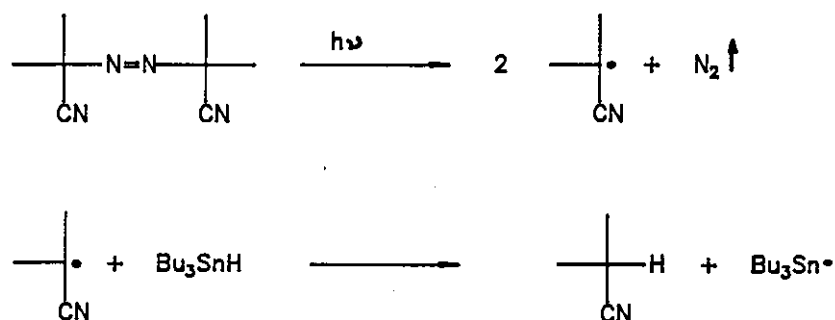

Scheme 14

1,2-Dimethyl-5-nitroimidazole (8), 1-(3-buten-1-yl)-2-methyl-5-nitroimidazole (78), and 1-allyl-2-methyl-5-nitroimidazole (77) were reacted with  $\text{Bu}_3\text{SnH}$  under the conditions outlined. In every case the result was a mixture of highly coloured breakdown products as witnessed in other reductions studies.

A more detailed analysis of these results is to be found in Section 2.5(b).

(d) Other reduction reactions of 5-nitroimidazoles

The reaction between 1,2-dimethyl-5-nitroimidazole (8) and sodium metal in liquid ammonia/*t*butanol is fully discussed in Section 2.5(c).

Crozet<sup>50</sup> has shown that 5-nitroimidazoles can react with the anion of 2-nitropropane by a single electron transfer mechanism to give the radical anion of the nitroimidazole. We attempted to repeat this reaction with the inclusion of thymine as an intermolecular trapping agent, (Scheme 11).

After refluxing 1,2-dimethyl-5-nitroimidazole (8), thymine (92) and the sodium salt of 2-nitropropane in benzene/water for 24 h whilst irradiating with tungsten white light lamps, none of the expected adduct (98) was found. The reaction gave only recovered unreacted starting materials and was not

studied further.

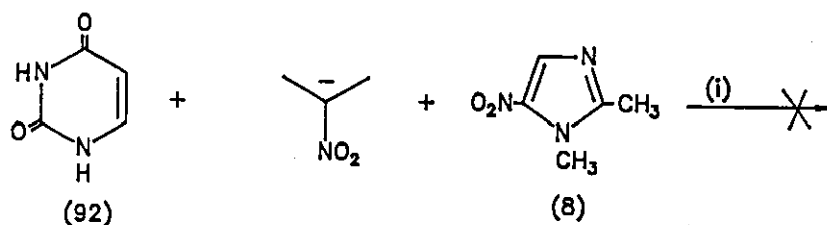

(e) Conclusion to Reduction Reactions

Our brief and incomplete studies of the reactivity of nitroimidazole radical anions did not produce any evidence to support the intermediacy or nitroimidazole radical anions as the active intermediate in the mechanism of action. More detailed studies could possibly still produce a clear identification of reactivity. We decided to abandon this section of the work because considerable time had been spent without tangible signs of success.

Further evidence against the radical anion as reactive intermediate has come from studies by Symons and co-workers<sup>56</sup> using radical anions of nitroimidazoles generated by  $\gamma$ -rays at low temperatures in the presence of DNA. No sign of interaction with DNA was observed at any time.

In contrast, the work of Crozet and co-workers,<sup>50</sup> has indicated the possibility of reaction between nitroimidazole radical anions and nucleophiles, albeit under fairly vigorous conditions.

The failure to observe any interaction of the nitroimidazole radical anion may not necessarily be significant. Many compounds that interrupt DNA production and function often only react at minimal and undetectable levels because even minute amounts of damage or DNA are magnified many times over during replication and thereby cause significant damage. Therefore, the radical anions of nitroimidazoles

could still be the reactive intermediate, but some evidence is required before they can be implicated.

## SECTION 2 PUTATIVE DISSOCIATION OF THE NITRO RADICAL ANION

### 2.1 DISSOCIATION OF THE NITRO RADICAL ANION

An alternative reaction as a possible mode of action involving the radical anion of nitroimidazoles has been proposed by Edwards,<sup>13,35</sup> Unlike other mechanisms put forward, this involved the dissociation of the radical anion to give a 5-imidazolyl radical and nitrite anion, (Equation 30). It was suggested that this imidazolyl radical could react with DNA to give a covalent adduct which would lead to strand breakage and death.

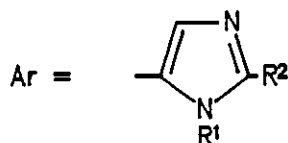

Although there is no other reported incidence of an aromatic nitro radical anion undergoing dissociation in this way, we decided that this process should be investigated further.

Our first aim was to generate the 5-imidazolyl radical and thereby its suitability as a reactive species in the mechanism of action. We decided to generate 5-imidazolyl radicals from the analogous 5-halogenoimidazoles because the carbon-halogen bond is weaker than the carbon-nitrogen bond in the nitroimidazole and dissociation is therefore more likely. Generation of a carbon radical centre from an aryl or alkyl halide is a very well researched area.<sup>57</sup>

We planned to trap the imidazolyl radicals generated by the radical reduction of selected 5-halogenoimidazoles by the

inter and intramolecular means described in Section 1.

## 2.2 SYNTHESIS OF HALOGENOIMIDAZOLES

In recent years, much has been discovered about the kinetics of halogenation of imidazoles,<sup>58,59</sup> although synthetic methods derive from the first quarter of the twentieth century. The bulk of the research was performed by Pauly,<sup>60,61</sup> Pyman<sup>62-64</sup> and their respective co-workers.

Some of the structural assignments made by Pauly<sup>60</sup> were before the advent of modern spectroscopic techniques and have subsequently been demonstrated to be incorrect.<sup>65</sup> For instance, base catalysed iodination of imidazole gives 4,5-di-iodoimidazole and not 2,4(5)-di-iodoimidazole as earlier reported.

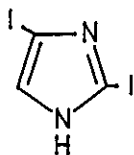

PAULY'S ASSIGNMENT

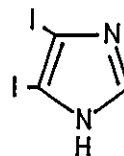

CORRECT ASSIGNMENT

### (a) Bromination of Imidazole

Selective bromination of imidazole, as described by Calo,<sup>66,67</sup> using 2,4,4,6-tetrabromocyclohexa-2,5-dienone (99), to give a 4(5)-bromoimidazole (100) (Equation 31), resulted in a mixture of the required material, 4,5-dibromo-2,4,5-tribromo-, and regenerated 2,4,6-tribromophenol (101).



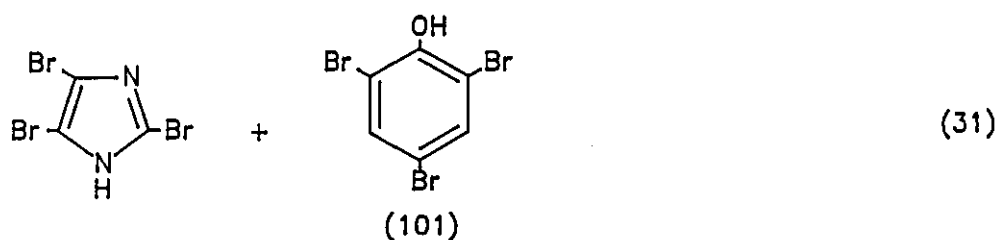
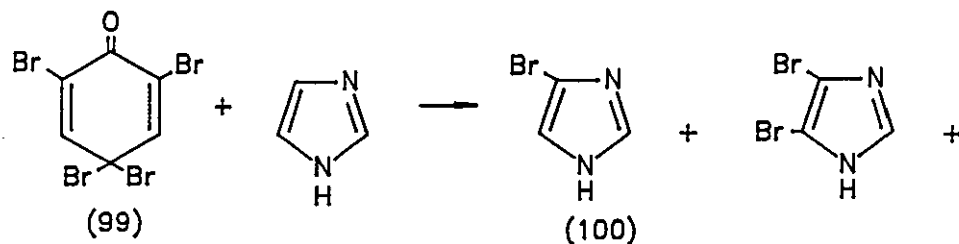

The dienone (99), was prepared from tribromophenol (101) by treatment with bromine in acetic acid, as shown in Equation 32. The dienone acts as a source of positive bromine and is converted back to the phenol.

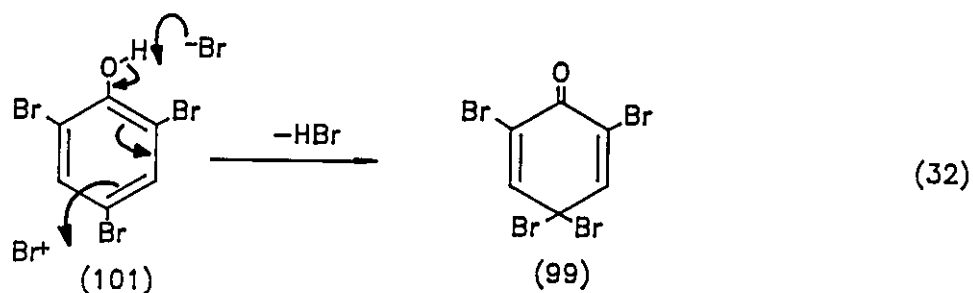

Polybrominated products arise from the equilibrium shown in Equation 33.

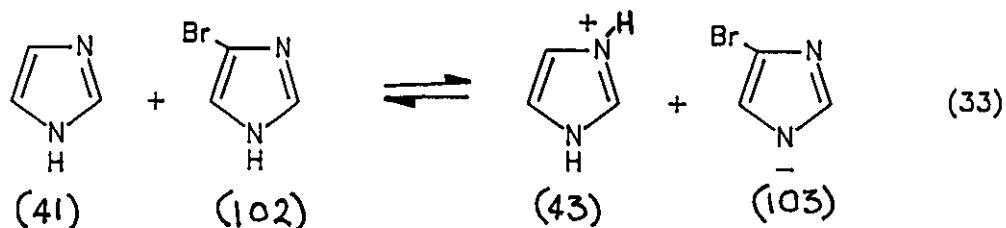

This method proved to be unsatisfactory on a large scale due to the complex separation required, and was abandoned in favour of polyhalogenation followed by reduction to give mono-substituted products.

At this point, imidazole was changed for 2-methylimidazole (104), because the C-2 methyl provided a convenient marker for n.m.r. spectroscopic identification. In addition, only one possible polybrominated product can be formed as opposed to two in the case of imidazole itself.

Brominations<sup>64</sup> were carried out in chloroform with bromine to give the hydrobromide salt of 4,5-dibromo-2-methylimidazole (105) which was basified to yield the free base (106), (Equation 34).

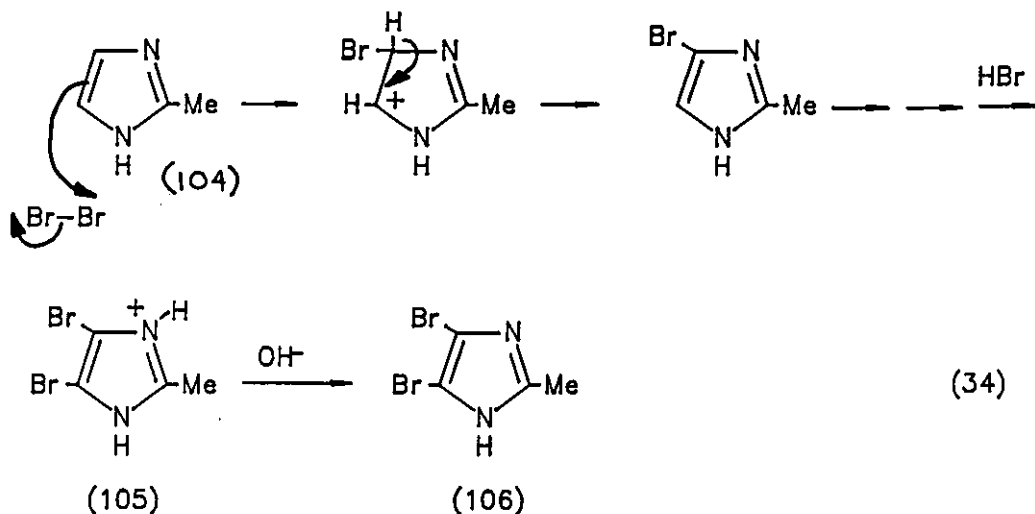

(b) Iodination of Imidazole

The iodinations<sup>60,61</sup> were also performed using 2-methylimidazole (104), by the action of iodine and 2 M aqueous sodium hydroxide solution. Unlike the bromination, (Equation 34), it is the anion which is iodinated to give the anion of 4,5-di-iodoimidazole. This anion (107) was then protonated by acidification with 2 M aqueous

hydrochloride acid to give 4,5-di-iodo-2-methylimidazole (108), (Equation 35).

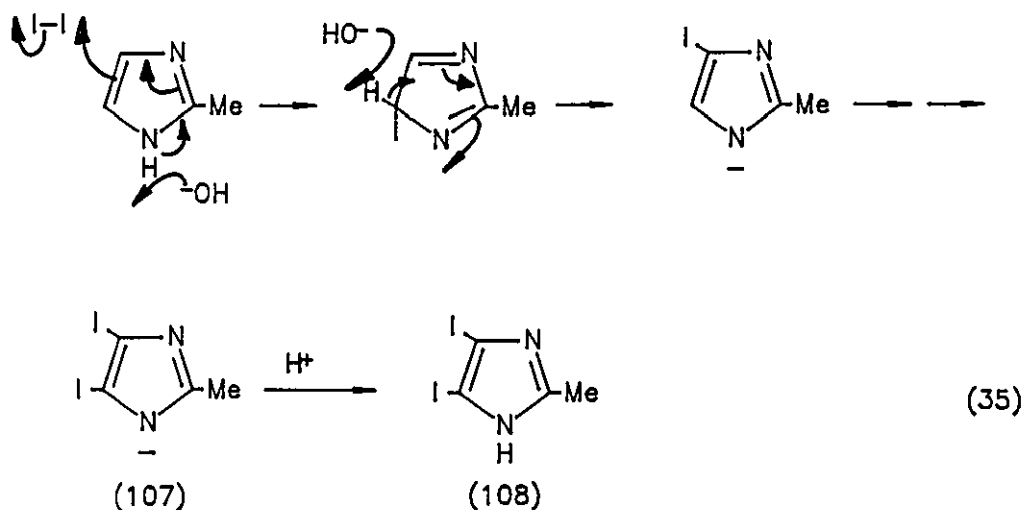

(c) Reduction of the dihalogenoimidazoles

Reduction of the dihalogenoimidazoles (106) and (108) by heating under reflux with 20% aqueous sodium sulphite solution<sup>68</sup> gave the desired monohalogenoimidazoles (109) and (110) in moderate to good yield, (Equation 36).

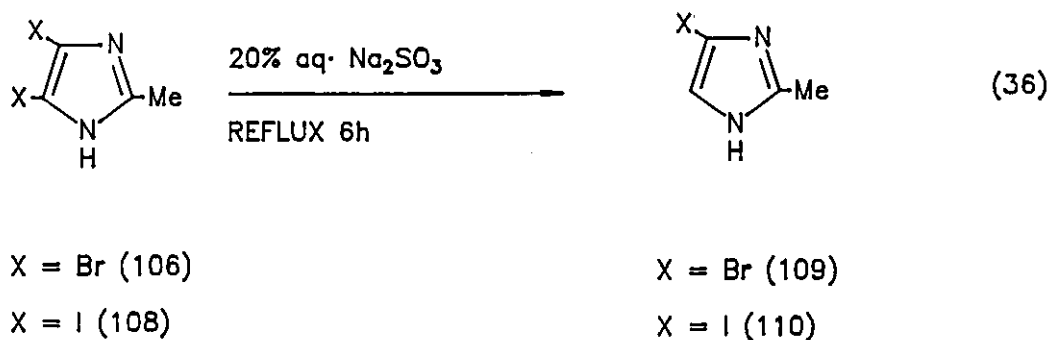

The mechanism involved in the reduction is unclear, proceeding by either a radical mechanism, (Scheme 15), or by the formation of an ylid<sup>69</sup> (Scheme 16).

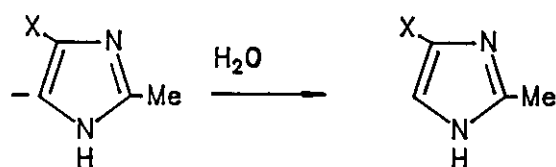
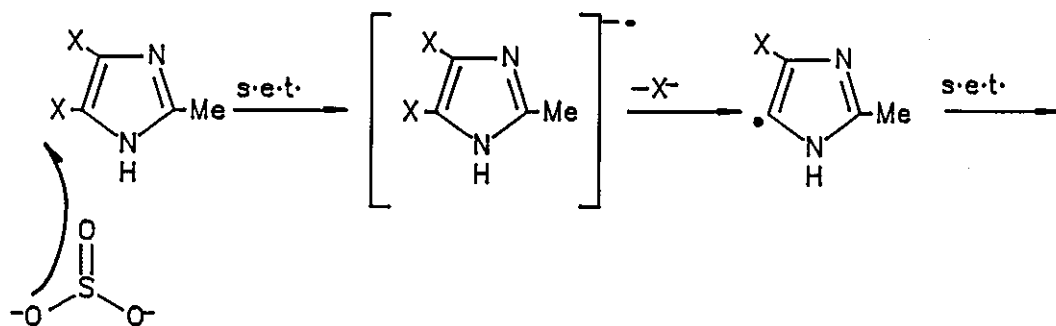

X = Br, I

Scheme 15

The radical mechanism can be used to explain the removal of only one halogen if the reduction potential of the sulphite is insufficient to reduce the monohalogenoimidazole and thereby remove the final halogen.

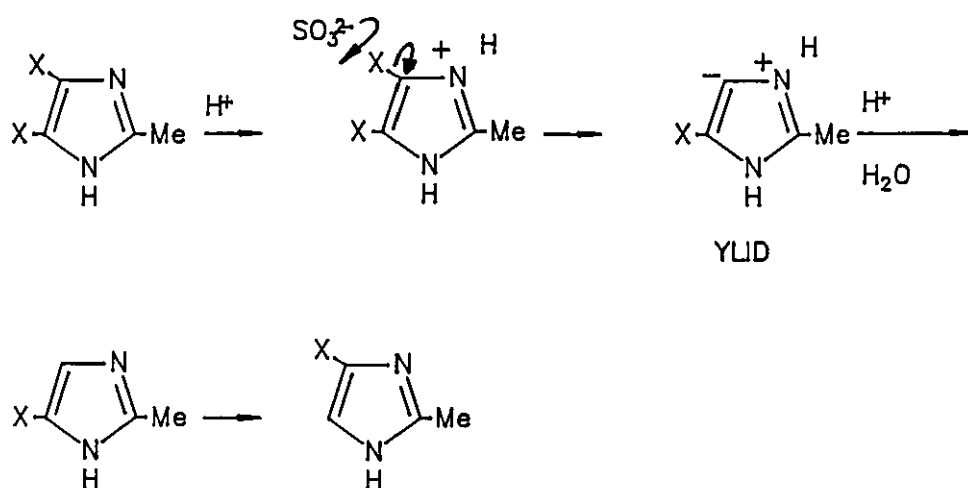

Scheme 16

Similarly, the ylid mechanism would indicate that reduction is halted because removal of the final halogen does not result in the formation of an ylid. (In the reduction of 2,4,5-tribromoimidazole the final product is 2-bromoimidazole.)

(d) Preparation of 1,2-dimethyl-5-halogenoimidazoles.

The synthesis of 1,2-dimethyl-5-halogenoimidazoles required for radical reduction studies proved troublesome. Due to the weaker directing effects of the halogens in comparison with nitro groups, all methylation routes normally used for the selective methylation of nitroimidazoles yielded approximately equal mixtures of the 4- and 5-halogenoimidazoles which are very difficult to separate because of their similar chemical properties.<sup>69</sup>

Only one route giving the required 5-isomers (111, 112) is described in the literature.<sup>70,71</sup> This route involves the treatment of 1,2-dimethylimidazole (113), with n-butyl lithium at  $-78^{\circ}\text{C}$  to give the anion at C-5, followed by reaction with a selective halogenating agent (e.g. N-bromosuccinimide), (Scheme 17).

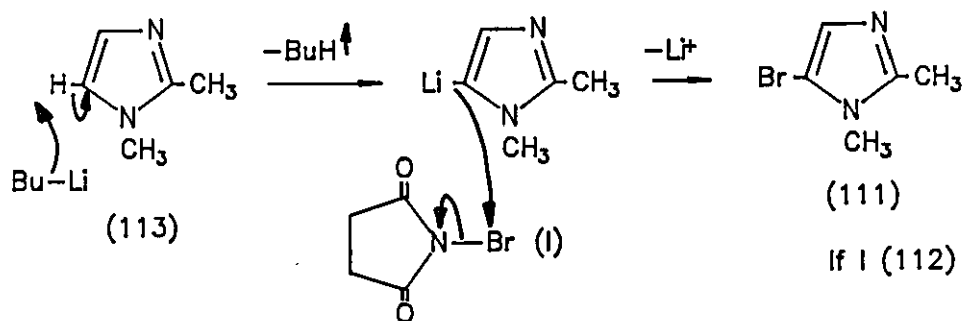

Scheme 17

The reaction proved unsatisfactory giving low yields (ca.

10%), together with some dibrominated material, presumably resulting from an excess of butyl lithium. Similar reservations about the original method of Tertov<sup>70</sup> were voiced by Iddon<sup>71</sup> in a subsequent publication.

A higher yielding alternative was developed from a method used for the alkylation of nitroimidazoles involving the treatment of the 4(5)-halogenoimidazole with methyl *p*-toluenesulphonate. The methylation, as shown in Equation 37, occurs at the pyridine-type nitrogen, N-3, to give a positively charged intermediate which deprotonates to give the desired isomer.

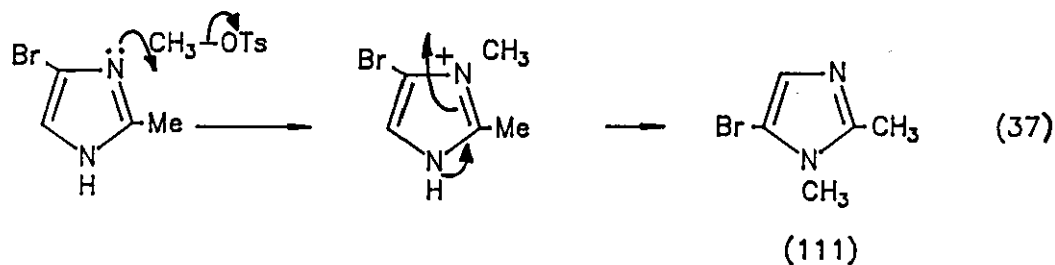

Attempts at methylation using diazomethane, which gives predominantly the 5-substituted isomer with nitroimidazoles, were unsuccessful resulting in a mixture of products. This surprising lack of specificity when compared with the corresponding nitroimidazole was probably due to the lower acidity of the N-H in the halogenoimidazole. It is assumed that the diazomethane is unable to abstract the less acidic proton from the halogenoimidazole as readily as it can for the nitroimidazole thus giving rise to products resulting from reaction at both N-1 and N-3.

An alternative route, (Equation 38), involving the methylation of the dihalogenoimidazoles by the action of dimethyl sulphate under alkaline conditions to give the dihalogenodimethylimidazoles, followed by reduction with tri-

n-butyltin hydride or sodium sulphite, proved unsuccessful.

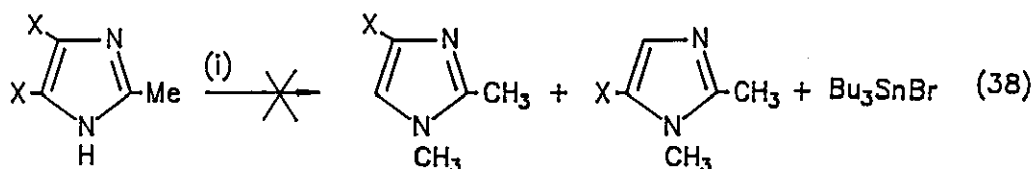

(i)  $\text{Bu}_3\text{SnH/AIBN/PhH/REFLUX}$

(e) Preparation of 1-alkenyl-5-halogenoimidazoles

Other alkylations were successfully carried out on the 4(5)-bromo-2-methylimidazole (109) using allyl- and but-3-en-1-yl p-toluenesulphonates (79,80), to give the corresponding N-substituted alkenylimidazoles, (114, 115), as shown in Equation 39.

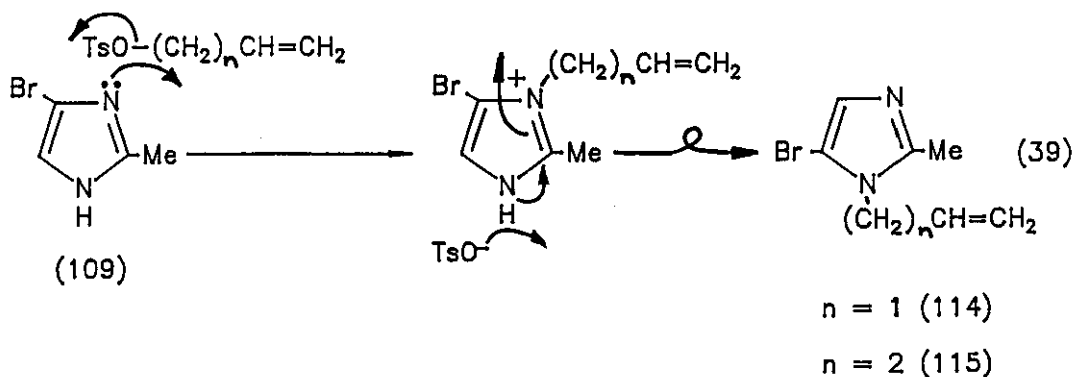

Unfortunately, attempts to prepare the 5-iodo analogues proved unsuccessful. We believe that this was due to the greater reactivity of the iodo compounds arising from their weaker carbon-halogen bond. As a result, the iodo products probably decomposed after formation under the severe reaction conditions which were employed. Had we been able to prepare the iodoimidazoles, useful kinetic comparisons would have been made in the subsequent reduction studies.

### 2.3 <sup>13</sup>C.N.M.R.SPECTROSCOPIC ANALYSIS OF HALOGENOIMIDAZOLES

Identification of the prepared halogenoimidazoles proved difficult because, as previously mentioned, their chemical and physical properties are similar. <sup>1</sup>H N.m.r. spectroscopy can be used to differentiate between the different N-methylated isomers but the chemical shift differences are small, typically 0.03 to 0.08 ppm. <sup>13</sup>C N.m.r. spectroscopy provided a useful means of distinguishing between the isomers as the shift differences were much larger, (ca. 52 ppm for iodine and 18 for bromine). The values obtained for imidazoles are analogous to those for furans and thiophenes with respect to the large upfield shifts.

The shift values for a number of imidazoles can be seen in Table 2. (Overleaf).

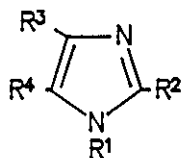

As can be seen from Table 2, <sup>13</sup>C n.m.r. spectroscopy gives unequivocal identification of chemically very similar halogenoimidazoles.

With a satisfactory technique for distinguishing between isomers, we were able to prepare pure samples of the desired 5-halogenoimidazoles for both e.s.r. spectroscopic studies and reduction/radical reactions.



CHEMICAL SHIFT  $\delta$ /ppm

COMPOUND	R <sub>1</sub>	R <sup>2</sup>	R <sub>3</sub>	R <sub>4</sub>	C-2	C-4	C-5	N-Me	C-2(Me)	OTHER
(41)	H	H	H	H	138.3	129.6	120.3			
(113)	Me	Me	H	H	144.9	126.8	120.4	32.6	12.6	
(106)	H	Me	Br	Br	145.8	106.2 <sup>a</sup>	105.9 <sup>a</sup>		14.0	
(116)	Me	Me	Br	Br	146.0	113.8	102.8	32.8	13.8	
(109)	H	Me	Br	H	144.5	112.1	114.9		13.6	
(118) <sup>b</sup>	Me	Me	Br	H	114.7	112.3	118.8	32.4	12.1	
(111) <sup>b</sup>	Me	Me	H	Br	145.3	126.7	102.0	30.9	13.5	
(111)	Me	Me	H	Br	145.5	126.5	101.6	30.9	13.5	
(114)	C <sub>3</sub> H <sub>5</sub>	Me	H	Br	145.8	127.7	102.1		13.9	46.7, 117.2 131.7 (CH <sub>2</sub> CH=CH <sub>2</sub> )
(108)	H	Me	I	I	150.0	84.7	84.7		13.8	
(117)	Me	Me	I	I	149.1	93.1 <sup>c</sup>	83.4 <sup>c</sup>	35.5	14.0	
(110)	H	Me	I	H	146.4	78.7	122.6		13.7	

Table 2: <sup>13</sup>C N.M.R. spectroscopic chemical shift ( $\delta$ /ppm) data for halogenoimidazoles.

a - Indicates a broad signal with two centres.

b - Calculated by subtraction of signals in a mixture of 4- and 5-bromo isomers.

c - Exact assignment uncertain.

2.4 ELECTRON SPIN RESONANCE (E.S.R.) SPECTROSCOPIC STUDIES  
OF HALOGENOIMIDAZOLES

All e.s.r. spectroscopic analyses and interpretations were carried out at Leicester University by Professor M.C.R. Symons and are intended for reference only.

A number of mono and di-halogenoimidazoles were analysed using e.s.r spectroscopy to determine the structure of their radical anions, if they were formed. It was hoped that we would be able to determine whether the radical anions would dissociate or not and if the result would be the 5-imidazolyl radical predicted by the dissociation theory.

The results obtained are shown in Table 3.

COMPOUND	R <sup>1</sup>	R <sup>2</sup>	R <sup>3</sup>	R <sup>4</sup>	X	NUCLEUS	HYPERFINE COUPLING/G <sup>a</sup> b	
							A <sub>  </sub>	A <sub>⊥</sub>
(109)	H	Me	X	H	Br	<sup>81</sup> Br	487	133
(110)	H	Me	X	H	I	<sup>127</sup> I	560	260
(111)	Me	Me	H	X	Br	<sup>81</sup> Br	433	153
(112)	Me	Me	H	X	I	<sup>127</sup> I	530	240
(116)	Me	Me	X	X	Br	<sup>81</sup> Br	480	130
(117)	Me	Me	X	X	I	<sup>127</sup> I	560	260

Table 3: The e.s.r. spectra of selected halogenoimidazoles.

a - 1 G = 10<sup>4</sup> T.

b - Results for CD<sub>3</sub>OD and the MeTHF were similar

NB A<sub>||</sub> = parallel hyperfine coupling constant (in Gauss)

A<sub>⊥</sub> = perpendicular.

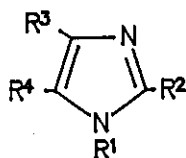

Preliminary results<sup>72</sup> and a full paper<sup>73</sup> reporting these results have been published.

The spectra were dominated by features characteristic of hyperfine coupling to halogen, over a wide field range.

Interpretation of these couplings indicates  $\sigma^*$  radical anions (119) rather than the expected  $\pi^*$  structures (120). The radical anions of halogenoimidazoles have structures in which the unpaired electron is situated in the  $\sigma^*$  orbital of the carbon-halogen bond and not as might have been predicted, in the  $\pi^*$  orbital of the imidazole ring.

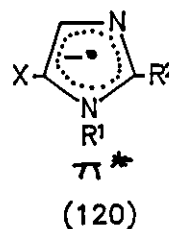
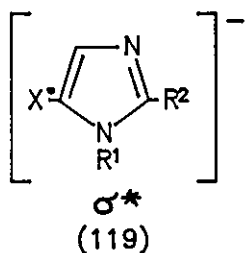

For the iodoimidazoles, but not the bromoimidazoles, raising the temperature from ca. 140K gave a second radical anion which was tentatively assigned to iodine atoms weakly bonded to CD<sub>3</sub>OD solvent molecules, (I<sup>•</sup>-O(D)CD<sub>3</sub>). Alternatively the species detected could be the radical anion, (CD<sub>3</sub>O-I)<sup>•-</sup>, resulting from proton loss. It would appear that for iodides, two possible routes of dissociation are available, (Equations 39a and 40).

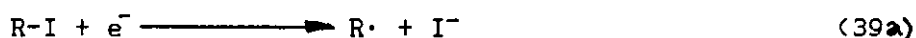

If the halogeno radical anions were to dissociate, there is unequivocal evidence that the precursor to dissociation is the  $\sigma^*$  radical anion. The tendency for dissociation for  $(R-X)^{\cdot-}$  to proceed to  $R^-$  and  $X^\cdot$ , rather than to  $R^\cdot$  and  $X^-$ , is favoured in the order:  $I > Br > Cl$ . This would indicate that any dissociation of the bromo radical anion would lead to a 5-imidazolyl radical and bromide anion. The reverse is true for the iodo radical anion.

These observations suggest that if the nitroimidazole radical anion did dissociate, it would be more likely to resemble the behaviour of the bromo radical than the iodo radical anion because the bond strengths and polarisation follow the trend,  $C-I < C-Br < C-NO_2$ .

## 2.5 REACTIONS INVOLVING THE 5-IMIDAZOLYL RADICAL

### (a) 5-Imidazolyl Radicals - Reactive Intermediates in the Mechanism of Action of Nitroimidazole Antibiotics?

The e.s.r. spectroscopic studies of halogenoimidazoles, (Section 2.4), have shown that the radical anions of halogenoimidazoles are stable species. Of the examples tested, iodides showed a tendency to dissociate to 5-imidazolyl anion and iodine radicals. The bromides tested did not dissociate under the conditions employed, but that does not preclude either of the possible dissociation routes under different conditions. We would, however, predict that the corresponding nitroimidazole radical anions would be less likely to dissociate than the bromoimidazoles due to the greater bond strength of the C-NO<sub>2</sub> with regard to the C-Br bond. In fact, nitroimidazole radical anions have been shown by e.s.r. spectroscopy to be especially stable, even for short times at room temperature.

### (b) Tri-n-Butyltin Hydride Reductions

Tri-n-butyltin hydride has been widely employed in organic synthesis as a source of radicals for chain reactions and the preparation of cyclic structures.<sup>57</sup> The relatively weak Sn-H bond is readily cleaved by the attack of a radical initiator, although thermal or irradiation initiation is also possible. One commonly used initiator is azobisisobutyronitrile (AIBN), which is cleaved by irradiation with white light, or heat, to give two radicals with the elimination of gaseous nitrogen, (Scheme 14).

5-Bromo-1,2-dimethylimidazole (111), 5-bromo-1-(but-3-en-1-yl)-2-methylimidazole (115), 1-allyl-5-bromo-2-methylimidazole (114) and 1,2-dimethyl-5-iodoimidazole (112) were used in the reduction studies. The reactions were carried

out in an atmosphere of dry oxygen-free nitrogen in refluxing toluene with  $\text{Bu}_3\text{SnH}$  (5 equiv.) and AIBN (0.1 equiv.), whilst irradiating with Tungsten White Light Lamps (150 W). The duration of the reaction was typically 48 h. Anhydrous reaction conditions were ensured by rigorous drying of the equipment.

We found that 5-bromo-1,2-dimethylimidazole (111) and 1,2-dimethyl-5-iodoimidazole (112) both gave 1,2-dimethylimidazole (113) in yields of 50 and 53% respectively. The yields were determined using  $^1\text{H}$  n.m.r. spectroscopy with an internal standard (*p*-dinitrobenzene). The identity of the 1,2-dimethylimidazole was confirmed by comparison with commercially available material.

The probable mechanism for these reactions is shown in Equation 41; abstraction of halogen by  $\text{Bu}_3\text{Sn}\cdot$  radicals to yield hydrogen from  $\text{Bu}_3\text{SnH}$  to yield the product (113) and  $\text{Bu}_3\text{Sn}\cdot$  radicals to yield the intermediate imidazolyl radical (121) which abstracts hydrogen from  $\text{Bu}_3\text{SnH}$  to yield the product (113) and  $\text{Bu}_3\text{Sn}\cdot$  radicals which act as the chain carrier.

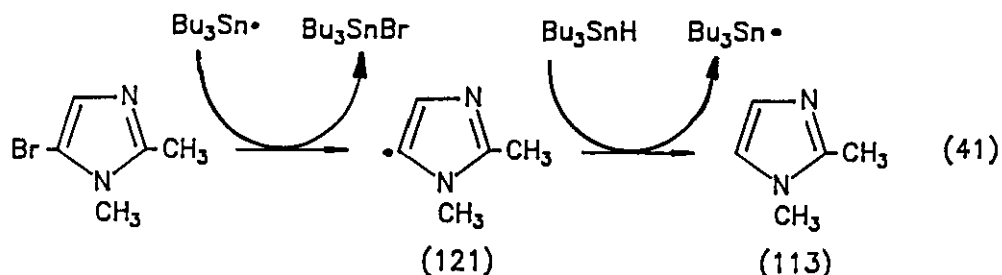

Oxygen gas and di-*t*-butylnitroxide are efficient radical traps and should inhibit chain reactions. Inhibition studies with oxygen gas replacing nitrogen gas or with added di-*t*-butylnitroxide (50 mol.%) gave reduced yields of (113) but did not fully inhibit the reactions. We believe that this incomplete inhibition was a result of the length and vigorous nature of the reaction conditions which possibly gave some  $\text{Bu}_3\text{SnH}$  radicals via a thermal route. However, the

reduction in yields indicates that the reaction probably proceeds via radical intermediates and a chain reaction.

Further evidence of the intermediacy of imidazolyl radicals was obtained by intramolecular cyclisation. 5-Bromo-1-(but-3-en-1-yl)-2-methylimidazole (115) was reduced under the same conditions as above to yield the novel cyclised imidazole (122) in 80% yield. We believe, as shown in Scheme 18, that cyclisation takes place prior to abstraction of hydrogen from  $\text{Bu}_3\text{SnH}$  leading to the formation of (122).

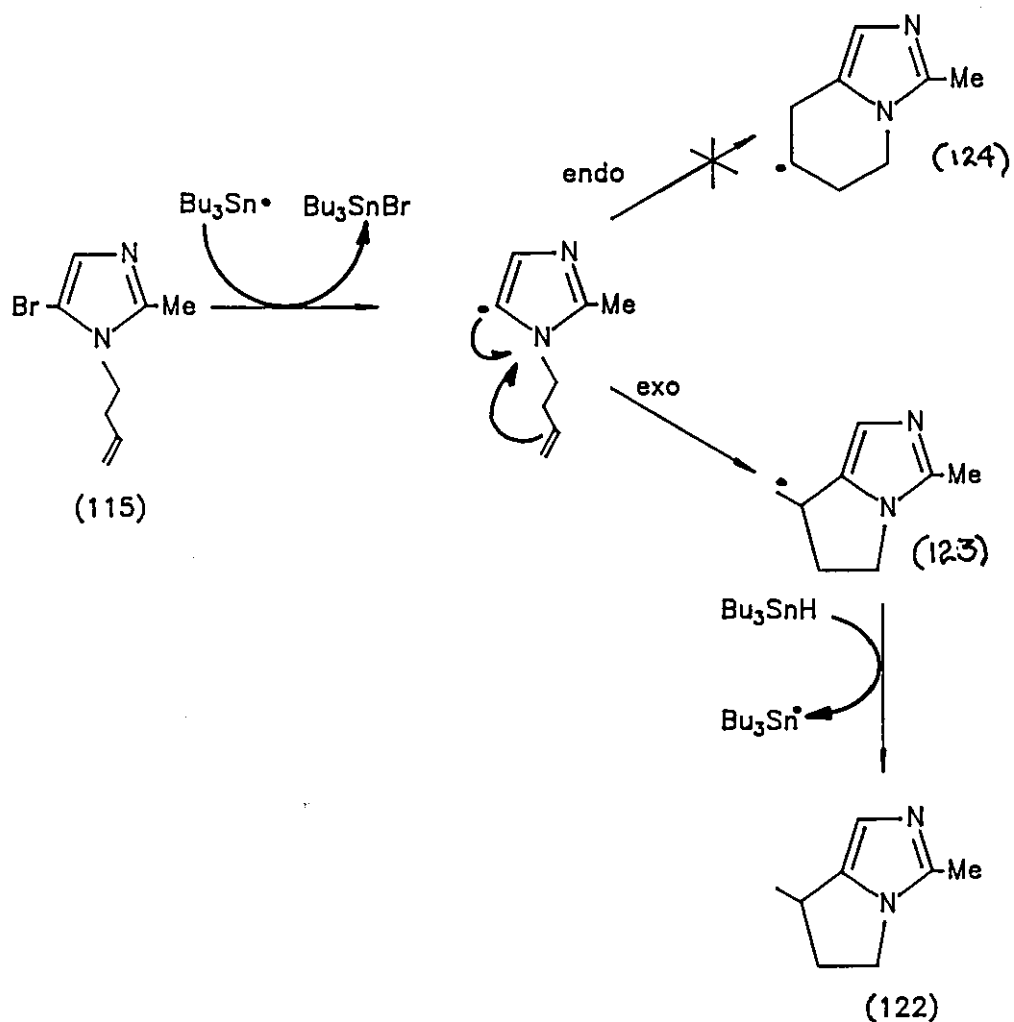

Scheme 18

As can be seen, two possible cyclisation routes are available either via an exo-5-membered ring intermediate radical (123) or an endo-6-membered ring intermediate radical (124). None of the product arising from the 6-membered ring intermediate (125) was observed. Although the reaction between an aromatic ring carbon atom and a carbon-carbon double bond is well documented,<sup>57</sup> we believe that our results are the first involving an intramolecular cyclisation using a 1-alkenyl-5-halogenoimidazole as precursor. It is possible that this reaction may be of synthetic importance as imidazoles are found in many naturally occurring compounds.

The cyclisation of o-butenyl radicals has been extensively studied <sup>74-76</sup> and only the product deriving from exo-cyclisation has been observed. Although the six-membered ring endo radical would be expected because it is more stable than the primary exo radical, the cyclisations are apparently under kinetic control and favour the 5-membered ring transition state.

When 1-allyl-5-bromo-2-methylimidazole (114) was reduced under identical conditions, the only product was 1-allyl-2-methylimidazole (126), resulting from a reduction (intermolecular trapping of the radical), as was observed in the case of the 1,2-dimethyl-5-halogenoimidazoles, (Scheme 19).

No material resulting from the intramolecular cyclisation of the 5-imidazolyl radical was observed. Examination of the two possible cyclic radical intermediates shows that the more favoured endo cyclisation would result in a highly strained four membered species (127), whereas a five membered intermediate arises from the less favourable exo cyclisation. As previously stated, endo cyclisation to yield a five membered ring is unfavoured. Even if the exo four membered ring product (127) were formed, the rate of ring opening is certainly much faster than ring closure and



therefore would not be expected.

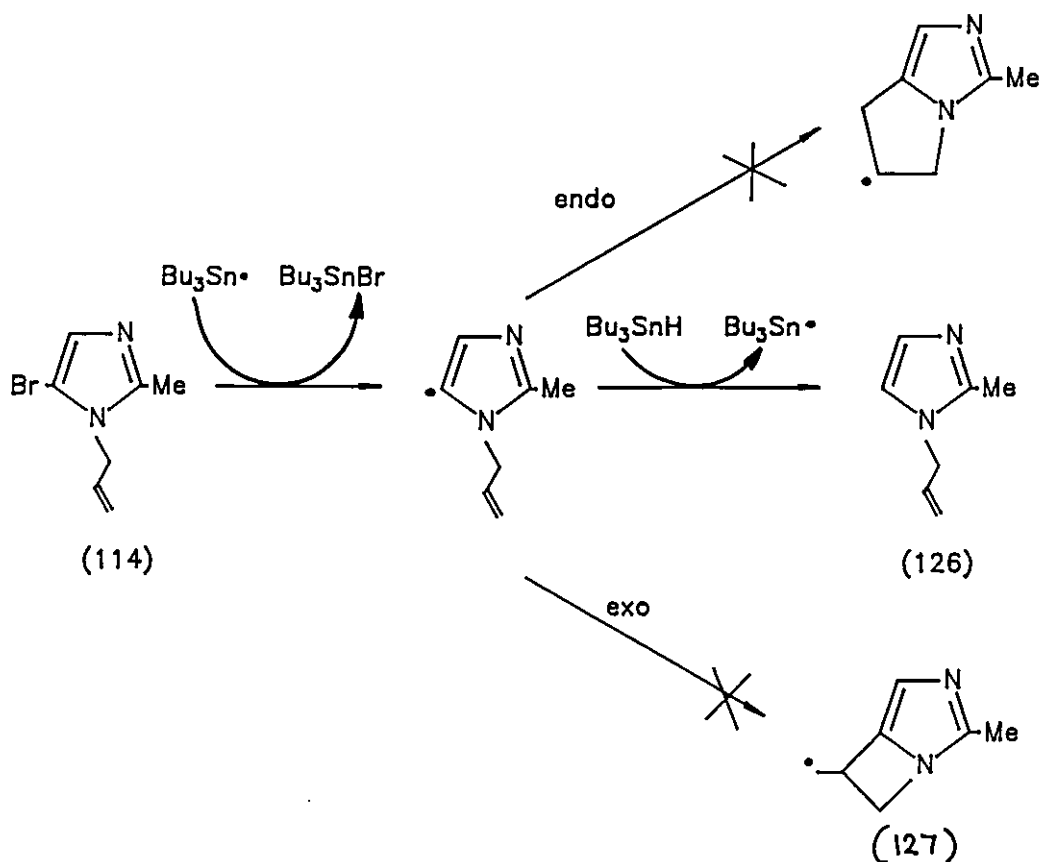

Scheme 19

From these results, we can suggest that the rate of cyclisation is greater than the rate of hydrogen abstraction providing that steric constraints are not excessive. Also, the rate of hydrogen abstraction appears to be greater than that of the endo cyclisation in the case of the allyl compound.

When 1,2-dimethyl-5-nitroimidazole (8) and 1-(but-3-en-1-yl)-2-methyl-5-nitroimidazole (78) were treated with  $\text{Bu}_3\text{SnH}$  under the same conditions, both gave a multitude of coloured breakdown products similar to those observed when dithionite or electrochemical reduction was employed, (see Section 1.4b).

$\text{Bu}_3\text{Sn}\cdot$  radicals are believed to be able to act as electron

donors (reductants) as well as abstracting groups (S<sub>H</sub>2 reactions). The bright colours would suggest that the former function is dominant, although the other routes may be in an equilibrium, (Scheme 20).

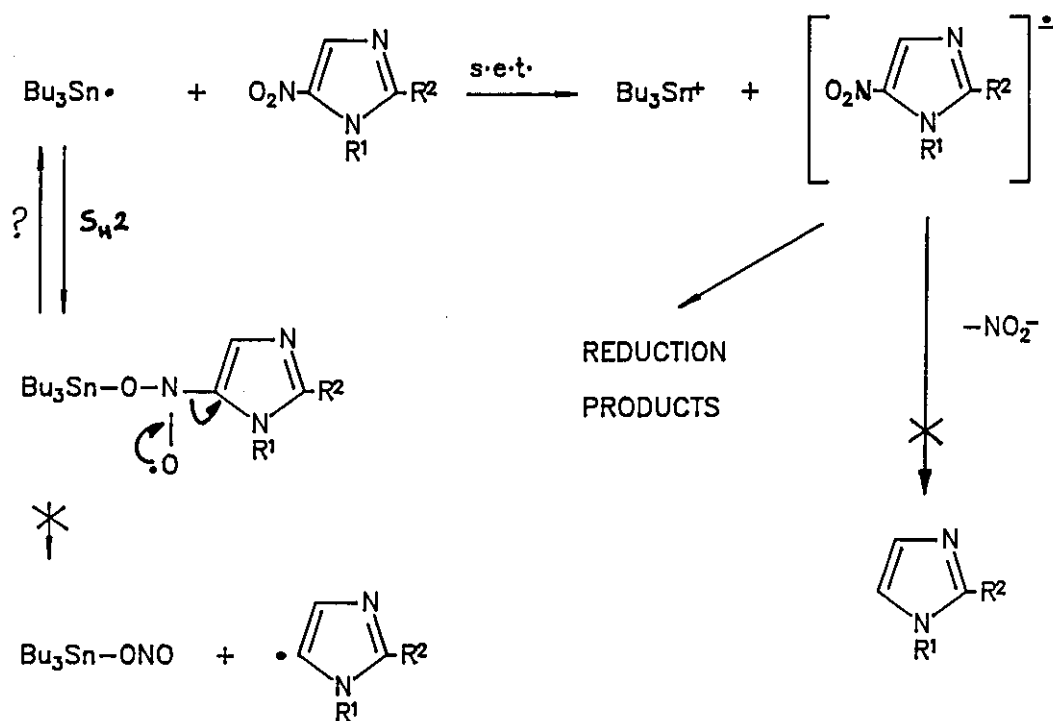

Scheme 20

(c) Sodium/Liquid Ammonia Reductions

Beckwith and Bunnett<sup>74</sup> have used a Na/NH<sub>3</sub>/t-BuOH system to study radical processes of analogous arene molecules, (Scheme 21), and therefore there is considerable evidence that reduction carried out using these conditions proceed via radical intermediates.

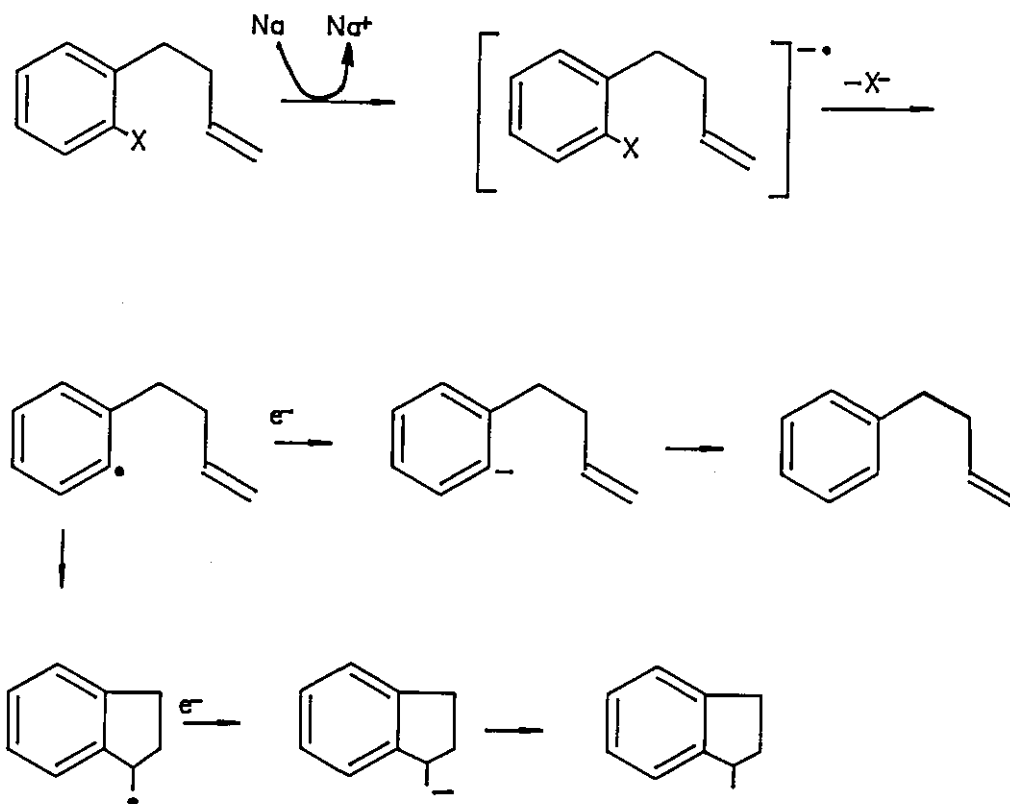

Scheme 21

5-Bromo and 5-iodo-1,2-dimethylimidazole were treated with sodium (3 equiv.) in  $\text{NH}_3/\text{t-BuOH}$  at ammonia reflux, under anhydrous oxygen-free  $\text{N}_2$ . In both cases, addition of the sodium resulted in a blue colour which persisted for about 5 minutes. After the colour had disappeared, the reactions were neutralised with ammonium nitrate and worked up as usual. Both substrates gave 1,2-dimethylimidazole as the sole product in 48 and 15% yields, (bromo and iodo respectively). The low yield from the iodo compound probably results from poor solubility in  $\text{NH}_3$ . The yields were determined by  $^1\text{H}$  n.m.r. spectroscopy with an internal standard (*p*-dinitrobenzene) and the identity of the products by comparison with authentic commercially produced material.

When 5-bromo-(but-3-en-1-yl)-2-methylimidazole (115) was treated using the same procedure, the blue colour observed

persisted for about 15 sec indicating a more rapid reaction. The product obtained was shown to be the novel cyclic material (122) resulting from intramolecular trapping of the 5-imidazolyl radical in almost quantitative yield.

The mechanism of this reaction (Scheme 22) involves an electron transfer from sodium to the imidazole substrate to give a radical anion (129). The radical anion can then either eliminate halogen radical to give a 5-imidazolyl anion (130), or it can eliminate halide anion to give a 5-imidazolyl radical (121), as outlined in the results of our e.s.r. spectroscopic studies (Section 2.4). If an imidazolyl radical results, a second electron transfer can result giving a 5-imidazolyl anion (130). Protonation of the anion yields 1,2-dimethylimidazole (113), as shown in Scheme 22.

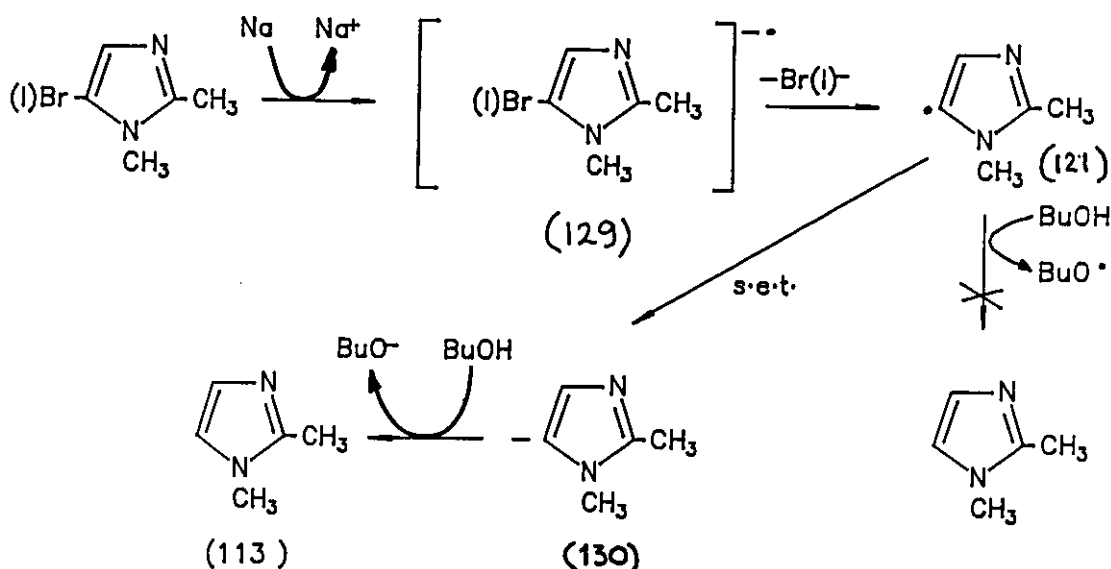

Scheme 22

When the substrate is the but-3-en-1-yl compound, the initial radical anion loses bromide anion to form the 5-imidazolyl radical (131). We believe that the radical cyclisation takes place to give the exo cyclic radical species (123) although there is a possibility that a second electron can add to give the 5-anion (132), and that the anion is the species which undergoes cyclisation, (Scheme 23). The evidence would suggest, however, that the former course of events is more likely.

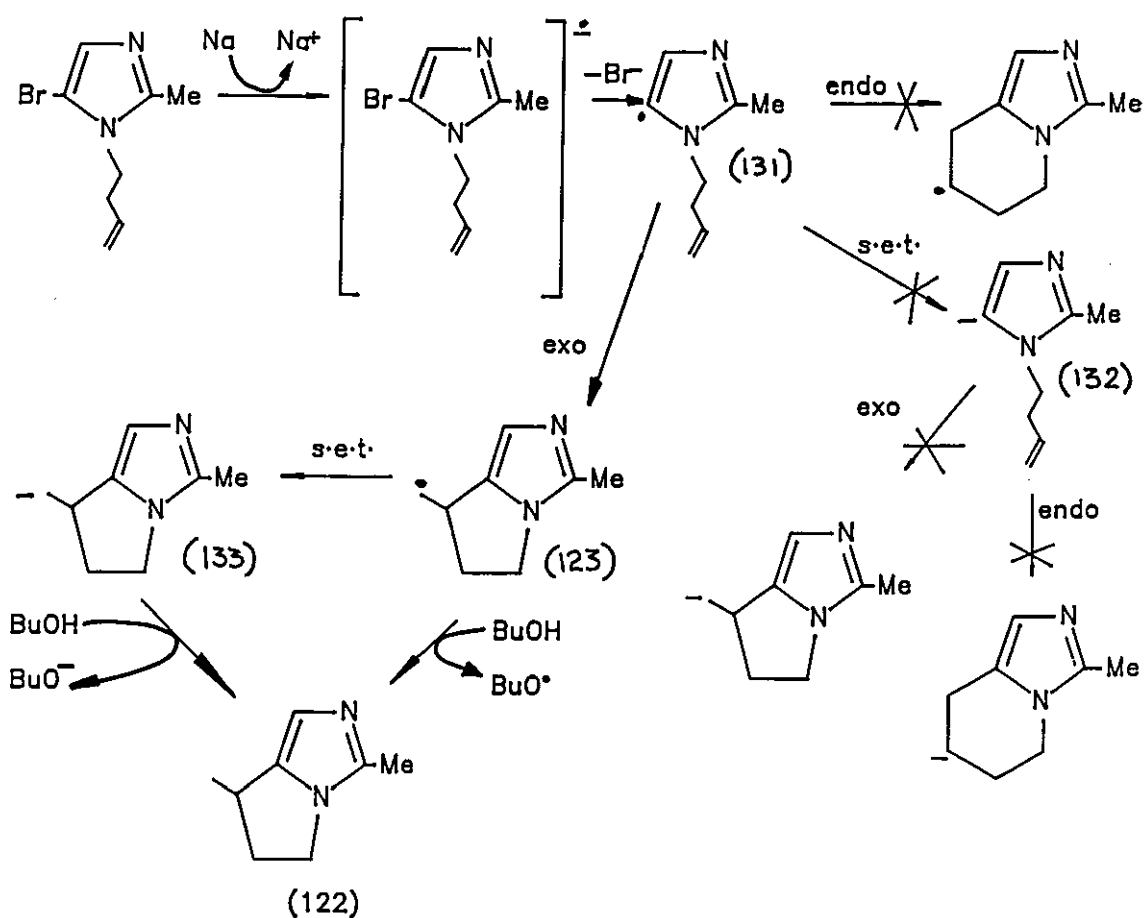

Scheme 23

The cyclic radical intermediate (123) can accept an electron to give the cyclic anion (133), as shown in Scheme 23, which then protonates to give the final cyclised product (122). A

less likely route would result from the abstraction of H $\cdot$  from t-butyl alcohol by the cyclic radical intermediate. Protonation by the t-butyl alcohol is a more favourable process than the aforementioned H $\cdot$  radical abstraction.

The rate of cyclisation ( $k_{cycl.}$ ) is obviously considerably faster than the rate of reduction ( $k_{redn}$ ) indicating yet again that this cyclisation is particularly favourable. A second possible mechanism, previously mentioned, has been shown not to be present in the corresponding arene reactions. Cyclisation via the 5-anion is also possible as shown in Scheme 23. Beckwith and Bunnett<sup>74</sup> have also pointed out that the rate of protonation of the phenyl anion is very much faster than the rate of cyclisation and therefore reduced non-cyclised material would be expected if the second reduction (to the anion) is faster than the cyclisation of the intermediate radical.

Study of the analogue 1-(but-3-en-1-yl)-5-iodo-2-methylimidazole, in which the radical anion may dissociate directly to the anion (128) by loss of I $\cdot$ , was precluded because the required N-butenyl-5-iodoimidazole could not be synthesised due to rapid decomposition during the butenylation.

As was observed for the Bu<sub>3</sub>SnH reductions, (Section 2.5b), the only cyclised material was that resulting from endo cyclisation for presumably similar reasons.

We believe that the iodo and bromo substrates react differently to each other in accordance with the above proposed reaction pathways. It is our belief that the iodo radical anion dissociates to give 5-imidazole anion and iodine radical, whereas the bromo radical anion dissociates to give 5-imidazolyl radical and bromide anion. This suggestion is in agreement with the results from our e.s.r. spectroscopic studies, (Section 2.4), where iodoimidazoles

were observed to dissociate preferentially as described. We would, however, have expected the cyclisation to have been unsuccessful or to have proceeded in lower yields than for the bromo analogue.

When analogous nitroimidazoles were reacted under the same conditions, addition of sodium gave rise to a red colour which persisted throughout work up. Both 1,2-dimethyl- and 1-(but-3-en-1-yl)-2-methyl-5-nitroimidazole gave a mixture of unreacted starting materials and coloured breakdown products. Neither gave any traces of the reduction of products observed for the analogous halogeno compounds, i.e. 1,2-dimethylimidazole, 1-allyl-2-methylimidazole. It is our belief that the red colour observed was associated with the nitro radical anion which appears to be quite stable. Due to the persistence of the red colour and therefore the apparent stability of the nitro radical anion, we suggest that the nitro radical anion is very unlikely to dissociate as no clear evidence of dissociation was seen.

Further, the lack of reactivity towards the intramolecular alkenyl group casts doubt on the possibility of reaction between the radical anion and some external species as a mechanism of action of nitroimidazole antibiotics.

#### (d) SRN1 Reactions

The term SRN1 is used to describe a unimolecular reaction involving a nucleophilic substitution reaction with a radical species. The mechanism for aromatic SNR1 reactions is shown in Scheme 24. A large number of aryl and heteroaryl substrates with X = halogen, OP(OR)<sub>2</sub>, SR, etc. have been shown to undergo radical nucleophilic substitution with a wide range of nucleophiles e.g. enolates, thiolates, phosphates, anions of alkyl cyano compounds, nitronates,

etc.

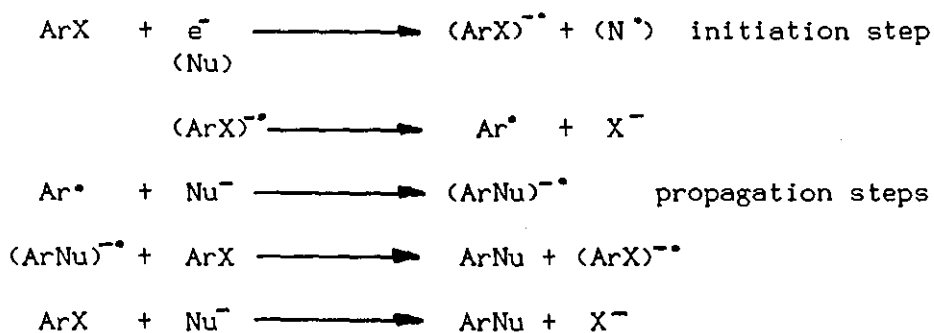

Scheme 24

#### SUMMARY

In the case of 5-halogenimidazoles, it is expected that s.e.t. gives a radical anion which would then dissociate to yield a 5-yl radical, which in turn would react with a nucleophile to give a new radical anion and eliminate halide anion, as shown in Scheme 25.

The  $\text{S}_{\text{RN}}1$  reaction therefore appeared an excellent reaction to show addition of an electron to give radical anion and dissociation of the radical anion to 5-imidazolyl radicals. The expected  $\text{S}_{\text{RN}}1$  mechanism is shown in Scheme 25. The intention was to show the  $\text{S}_{\text{NR}}1$  mechanism for halogenimidazoles and then apply it to nitroimidazoles for comparison as done in the  $\text{Bu}_3\text{SnH}$  and  $\text{Na}/\text{NH}_3$  reactions.

We used reaction conditions previously employed with success on aromatic and heterocyclic substrates.<sup>77,78</sup> 1,2-Dimethyl-5-halogenimidazoles were treated with sodium hydride under oxygen-free nitrogen. The reaction mixture was irradiated, (350 nm), during the course of the reaction. The nucleophiles used were diethylphosphite and *p*-chlorothiophenol.



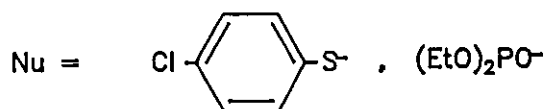
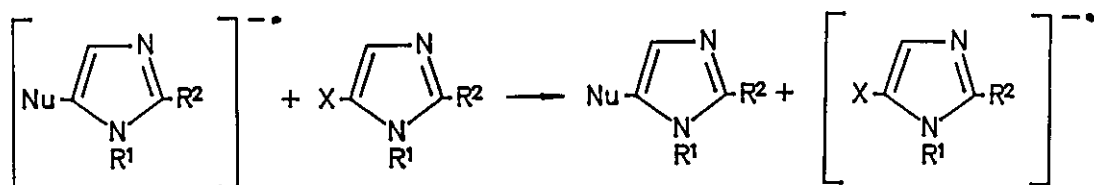
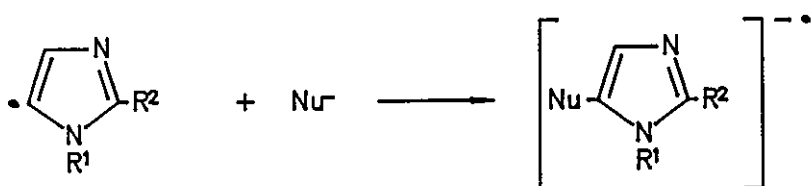
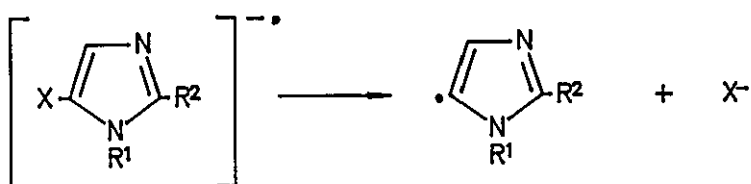
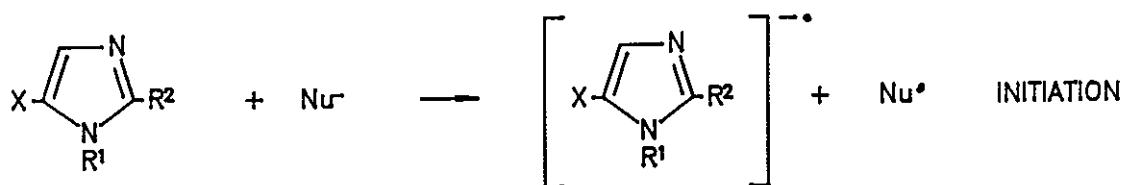

Scheme 25

Despite repeated reactions using prolonged forcing conditions, no adducts resulting from successful  $S_{RN}1$  reaction with diethylphosphite (134) or *p*-chlorothiophenol (135) were observed.

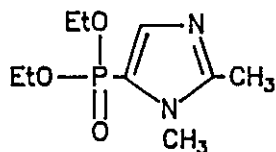

(134)

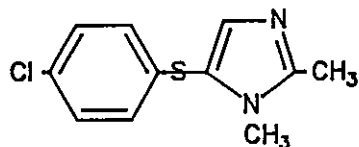

(135)

Alternative reaction conditions, (Na/NH<sub>3</sub> and *p*-chlorothiophenol at ammonia reflux for 6h), also gave none of the expected product.

The lack of reaction is surprising, particularly as phenylthiolate has been reported to undergo  $S_{RN}1$  reactions with iodobenzene, 2-chloro-pyridine, quinoline, and pyrimidine, and with 4-bromoquinoline.<sup>79-81</sup> Iddon and co-workers<sup>82</sup> also reported that phenylthiolate does not react with 5-bromo-1,2-dimethylimidazole in dioxane or dimethyl sulphoxide, but irradiation was not used. Reaction<sup>82</sup> between phenylthiolate and 2,4,5-tribromo alkylimidazoles gave substitution at the 2-position, but presumably by an  $S_{RN}1$  mechanism.

Whilst disappointing the results indicate that the halogenoimidazoles are relatively stable under quite vigorous conditions and that they resist reaction with nucleophilic species. The most probably explanation for the lack of reaction is the lack of initiation, i.e. the nucleophiles are not able to transfer electrons to the halogenoimidazoles. Nitroimidazole radical anions, which have been shown by e.s.r. spectroscopy to be more stable than their halogeno analogues, would therefore appear less likely to react. The consequence is that  $S_{RN}1$  type reactions between nitroimidazoles and nucleophiles in the much milder

conditions of the cells, would seem unlikely as a possible mechanism of action.

## 2.6 CONCLUSIONS

The studies using 5-halogenoimidazoles as precursors for 5-imidazolyl radicals were undertaken to examine the dissociation of nitroimidazoles as a potential mechanism of reaction. We have discovered that halogenoimidazoles can be reduced to give 5-imidazolyl radicals which in turn can be trapped inter and intramolecularly. Also, we have shown that under identical reaction conditions, nitroimidazoles do not dissociate but decompose to give a multitude of coloured reaction products typical of the reductions of nitroarenes.

E.s.r. spectroscopic studies showed that the radical anions of halogenoimidazoles were surprisingly stable, although iodides did dissociate even at low temperatures.

Furthermore, the radical anions were not the expected  $\pi^*$  type, but were  $\sigma^*$ , that is the unpaired electron resides in the C-X bond and is not delocalised in the aromatic ring. This discovery in itself is of importance, being unusual, but moreover, indicates that the C-X bond is stronger than would otherwise have been expected, (bond order effectively 1.5), (i.e. a three electron bond as shown below).

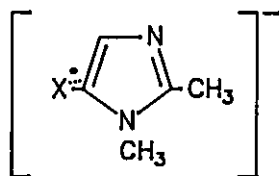

An indication of this stability can also be seen when the electron distribution in the contributing canonical forms is considered, (Equation 42).

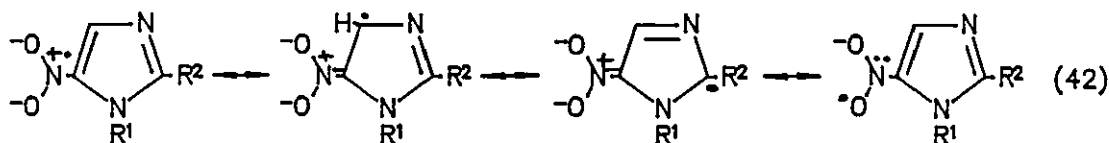

It has been shown that 25% of the contributing structure have C=N character which means that the overall order of the C-N bond is greater than 1, suggesting dissociation is unlikely.

We have demonstrated that the 5-imidazolyl radical is a feasible intermediate in the mechanism of action of nitroimidazole antibiotics, but the proposed process leading to the formation of the 5-imidazolyl radical is unlikely. The work of Crozet<sup>50</sup> has shown a possible source of nitrite anion, thus explaining the reason underlying the observation which originally led Edwards to suggest the dissociation theory.<sup>13,35</sup>

The nitrite observed in biological studies is undoubtedly formed but our results suggest that it arises from some biological reaction other than the dissociation of the nitro radical anion. Possibly some, as yet undetected, interaction between DNA and the nitro radical anion leads to nitrite elimination.



When we consider the fate of the nitro radical anion in the aqueous environment of the cell, we can assume that the radical anion exists not as an independent species, but hydrogen bonded to water molecules. Evidence in support of this comes from studies of the reaction of halogeno-nitroalkanes in which Bowman and Co-workers<sup>83</sup> have shown that protic solvation of nitro compounds plays an important role in their reactivity. It is likely that if the intermediate radical anion is solvated, the nitroimidazole itself will probably be solvated also. This solvation (protonation) would lower the energy of the orbital and make electron capture easier.

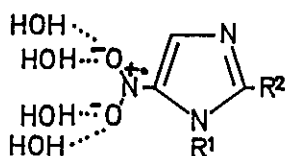

It would also appear likely that rapid protonation occurs giving, by a series of stages, the next intermediate in the reduction sequence, namely the nitrosoimidazole, (Scheme 26).

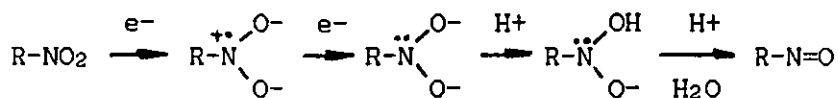

OR

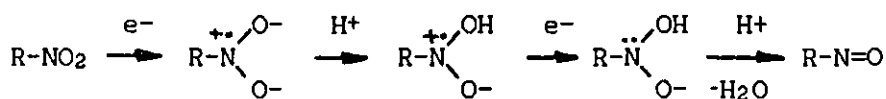

Scheme 26

The alternative route to the nitroso compound from the nitro radical anion via a bimolecular reaction between ( $\text{RNO}_2^{\cdot-} + \text{RNO}_2^{\cdot-}$ ), ( $\text{R-N}\ddot{\text{O}}_2 + \text{R-N}\ddot{\text{O}}_2\text{H}$ ), or ( $\text{R-N}\ddot{\text{O}}_2\text{H} + \text{R-N}\ddot{\text{O}}_2\text{H}$ ) is unlikely.

The concentration of the drug in the cell is likely to be low in the proximity of the point of reduction and therefore the aforementioned bimolecular reactions are improbable. It would seem that the lifetime of the radical anion is identifiable because O<sub>2</sub> will interrupt nitroimidazole activity by reaction at the radical anion stage.

(b) Strategy of the Investigation

Isolation of nitrosoimidazole reactive intermediates in biological studies have to our knowledge not been reported in the literature, and the preparation and reaction of nitrosoimidazoles are similarly scarce. These two factors appear to have caused most researchers to largely ignore the nitrosoimidazole as a possible reactive intermediate. However the short lifetime of the nitroso species in the reduction sequence of nitrosoimidazoles may also indicate high reactivity, and the lack of research into the preparation of nitrosoimidazoles stems from the apparent lack of any use.

It was our intention to synthesise the couple of nitrosoimidazoles reported in the literature,<sup>39,84,85</sup> to attempt to synthesise novel examples analogous to commonly used nitroimidazoles, and to react the resultant compounds with primary aromatic amines or thiols which are model compounds for reaction in the cell.

### 3.2 PREPARATION OF NITROSOIMIDAZOLES

#### (a) Preparation of Nitrosoimidazoles Reported in the Literature

The only nitrosoimidazoles reported in the literature to our knowledge are 2, 5(4)-diphenyl-4(5)-nitrosoimidazole (136), 4(5)-nitroso-5(4)-phenylimidazole (137), and the two N-methyl derivatives (36) and (37). Attempts to prepare 4(5)-methyl-5(4)-nitrosoimidazole (138) by a similar route were reported to be unsuccessful, giving multiple decomposition products.<sup>84</sup>

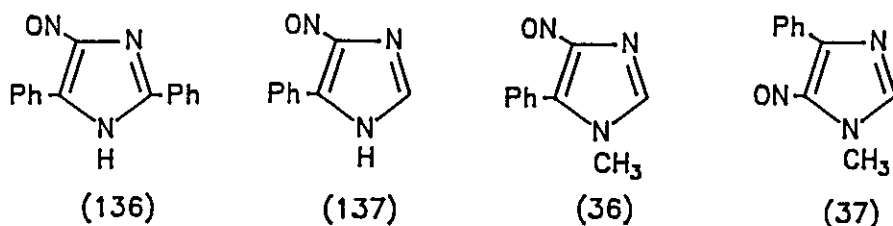

We synthesised 4(5)nitroso-5(4)-phenylimidazole (137) by the method reported by Calo *et al*<sup>85</sup> and by Ehlerdt *et al*,<sup>39</sup> in which 4(5)-phenylimidazole (139) is treated with Na/MeOH to give the anion (140), and subsequently with isoamyl nitrite to give the anion (141) of the nitroso compound. Work up consisted of quenching with water followed by ether extraction to remove isoamyl alcohol, produced as a by-product, and careful treatment of the aqueous phase with CO<sub>2</sub> to precipitate the nitrosoimidazole (137), (Equation 44).

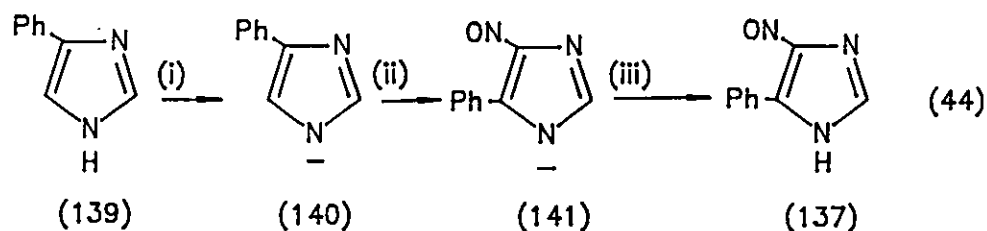

(i) EtOH/Na; (ii) C<sub>5</sub>H<sub>11</sub>ONO/N<sub>2</sub>/3 DAYS; (iii) CO<sub>2</sub>/H<sub>2</sub>O



We found that yields were disappointing compared with those reported in the literature, (65%), our best being about 9%. This disparity was, we believe, a result of insufficiently dry EtOH. Despite drying of the apparatus and using EtOH freshly distilled from Mg/I<sub>2</sub>, no significant increase in yield was observed. As a result of trial and error, we found that yields of 50 to 60% were possible when MeOH was used instead of EtOH. MeOH being readily dried. The optimum reaction time was found to be 3 days.

The recommended purification was by recrystallisation from a small quantity of acetone or from aqueous EtOH. Both of these methods resulted in losses of product of 80%. We were surprised at the suggested purification procedures because Beaulieu and Goldman<sup>39</sup> reported reactions between the nitrosoimidazole and water or MeOH. Alternative purification techniques were limited by the lack of solubility in most organic solvents and the sensitivity toward acid. Chromatographic and spectroscopic analysis of the crude material showed there to be only relatively low levels of contaminants and the crude material was taken to the next stage without further purification. Samples of recrystallised material were analysed using high field <sup>1</sup>H n.m.r. and e.s.r. spectroscopy.

The mechanism of the reaction is fairly straightforward, involving removal of a proton from the starting material (139) to give the anion (140). We believe that the anion then attacks the isoamyl nitrite displacing amoxy anion. On work up, the nitrosated imidazole anion (141) is protonated to give the product which precipitates out of solution, as shown in Equation 45.

When we prepared the reaction using 4(5)-methylimidazole (142), 2-methylimidazole (104), and imidazole (41) work up yielded a mixture of decomposition products which could not be separated or identified. These observations were in

accordance with those in the literature.

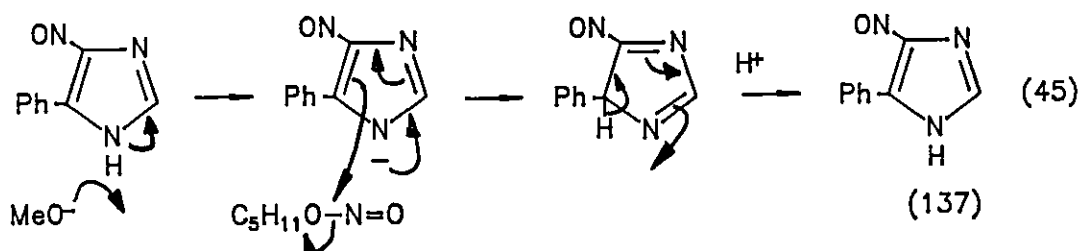

A possible explanation for the difference in reactivity is that the phenyl groups stabilise the nitroso intermediate whereas the methyl groups cannot. Such stabilisation would explain why the literature cites two examples both of which possess a phenyl substituent at the 4-position. It may be that substituents other than phenyl can stabilise the anionic intermediate sufficiently but unfortunately we were unable to pursue this particular approach.

Methylation of 4(5)-phenyl-5(4)-nitrosoimidazole (137) using methyl iodide/acetone/potassium carbonate, gave a mixture of 1-methyl-4-nitroso-5-phenylimidazole (36) and 1-methyl-5-nitroso-4-phenylimidazole (37), as reported in the literature.<sup>39</sup> Whilst giving some product, it proved to be low yielding. The literature reports of this methylation deal with 10 mg of compound and attempts to scale up to a synthetically useful level, (0.5 g and greater), resulted in large quantities of reddish decomposition products, (Equation 46).

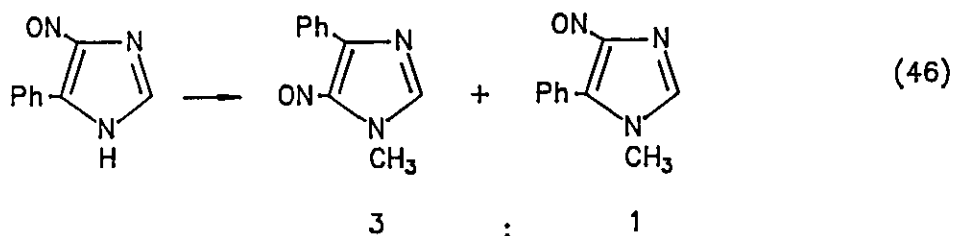

The method is reported to preferentially give the 5-nitroso isomer (37). The mechanism could either involve deprotonation of the imidazole by the potassium carbonate to give the anion which then reacts with the methyl iodide or the lone pair of N-3 attacks the methyl iodide directly. The resulting 3:1 ratio of 5-nitroso to 4-nitroso products would indicate that the same type of electronic effect as a nitro substituent but of smaller magnitude. The phenyl groups could influence the direction of reaction sterically. The directing effect on the nitroso group is difficult to predict but if similar to the nitro group, the predominance of the 5-NO product would suggest the second mechanism, (Scheme 27).

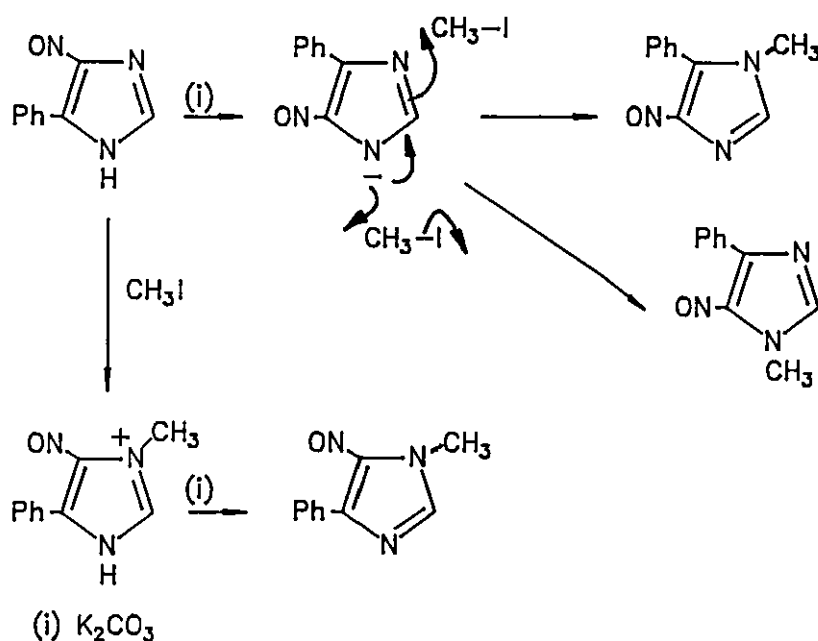

Scheme 27

After trying the methylation techniques employed successfully on nitroimidazoles, methyl *p*-toluenesulphonate and dimethyl sulphate, without success, we found that diazomethane gave the required product in good yield. 4(5)-Nitroso-5(4)-phenylimidazole (137) was dissolved in

anhydrous ether and treated with an ethereal solution of diazomethane. The imidazole was only partially soluble in the quantity of ether used giving a green solution. Addition of the ethereal diazomethane caused a change of colour from green to red and the gradual solution of the imidazole as the reaction proceeded. The reaction was terminated when all the imidazole had been dissolved and the ether removed under reduced pressure. The residue was chromatographed on a short column which gave a green band of the desired product. Any unreacted starting material was left at the top of the column and the red decomposition products were easily separable. The fraction containing the product was evaporated to dryness under reduced pressure to give a green solid which was further purified by recrystallisation from petroleum ether (b.p. 100-120°C). Reaction times of about 15 min gave the best yields (~60%), the yield dropping rapidly as the reaction time increases due to the formation of the reddish secondary products. Reaction using THF as solvent gave low yields because the starting material is more soluble and therefore reacts more quickly with the diazomethane and is consequently difficult to control, (Equation 47).

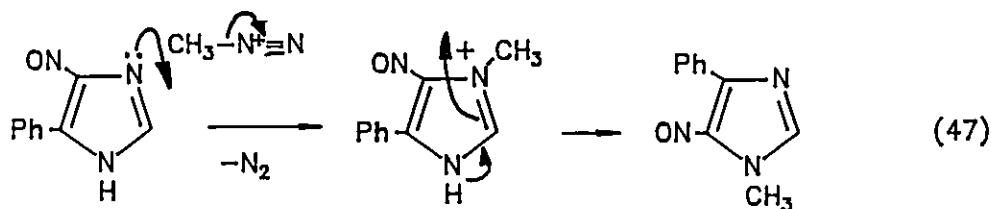

The rapid reaction with diazomethane suggests that the nitrosoimidazole N-H is more acidic than the corresponding nitroimidazole N-H. Reaction with diazomethane, as mentioned previously (Section 1.1a), involves protonation of the diazomethane, which is in turn dependent on the acidity of the proton being removed. Comparison of the reaction

times of nitro and nitrosoimidazoles, 12 h and 15 min respectively, indicates a difference in their relative acidities.

(b) Preparation of Novel Nitrosoimidazoles

Our main target was the synthesis of the nitroso analogue of dimetrimidazole, (1,2-dimethyl-5-nitroimidazole), 1,2-dimethyl-5-nitrosoimidazole (143). We tried to synthesise 2-methyl-4(5)-nitrosoimidazole (144) by treatment of 2-methylimidazole with sodium methoxide and isoamyl nitrite as for the phenyl compound in Section 3.2a. This resulted in only decomposition products.

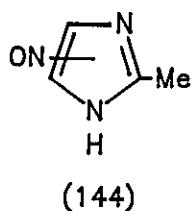

We then turned our attention on the reaction between 1,2-dimethylimidazole and isoamyl nitrite. This reaction would involve the abstraction of a proton from the imidazole ring at the 5-position by a strong base, and then subsequent reaction with isoamyl nitrite would give the required product, (Equation 48).

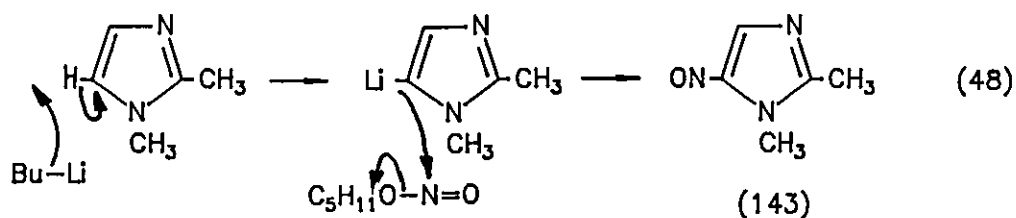

The obvious choice of base was butyl lithium. Iddon and co-workers<sup>71</sup> have carried out many of this type of reaction involving a wide range of electrophiles in various solvents and at various temperatures. The best results seem to come from using ether or THF, as the solvent, at about room temperature. It appears that the choice of solvent/temperature system to some extent determines the site of attack by the butyl lithium and therefore the product resulting.

We repeated the reaction performed by Iddon and Lim<sup>71</sup> between 1,2-dimethylimidazole and benzophenone in ether at room temperature to test out technique. The resulting yield and proportion of the two carbinols resulting from reaction at the C-2-Me and C-5 positions were in accordance with that reported in the literature<sup>71</sup> (Equation 49).

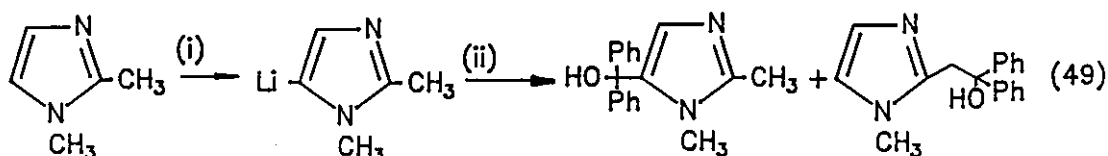

(i) BuLi/Et<sub>2</sub>O

(ii) Ph<sub>2</sub>C=O

A solution of 1,2-dimethylimidazole in anhydrous ether was treated with ~10% solution of *n*-butyl lithium in hexane at room temperature under an atmosphere of nitrogen. After 1 h, isoamyl nitrite was added carefully and the resulting mixture was allowed to stand for 0.5 to 18 h. A quantity of methanol was added followed by water and the reaction mixture was extracted with ether. The ethereal extracts contained unreacted 1,2-dimethylimidazole only. At no time did we observe any of the expected product or any species which resembles an aromatic nitroso compound. Repeated reactions involving THF as solvent, low temperatures (-5 to -78°C) or changes in the reaction times gave no nitrosated

imidazole.

An alternative to the direct reaction of 1,2-dimethylimidazole with isoamyl nitrite is to first introduce a good leaving group, such as trialkylsilyl or trimethylstannyl, followed by electrophilic substitution with a source of  $\text{NO}^+$ . Bartlett *et al*<sup>86</sup> were able to synthesise a number of aromatic nitroso-compounds (145) by reacting substituted trimethyl(phenyl)stannanes (146) with nitrosyl chloride (147), (Equation 50).

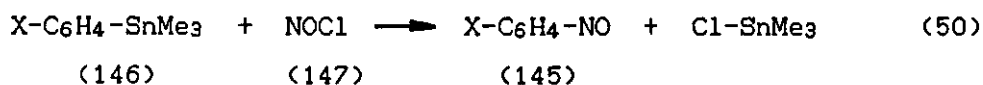

Unfortunately, the prohibitive cost of nitrosyl chloride prevented us from attempting an analogous reaction with a 5-trimethylstannyl substituted imidazole.

We attempted to synthesise 1,2-dimethyl-5-trimethylstannylimidazole (148) and 1,2-dimethyl-5-trimethylsilylimidazole (149) as described by Iddon *et al*<sup>71</sup> by treating 1,2-dimethylimidazole with BuLi in ethereal solution with either chlorotrimethylstannane or chlorotrimethylsilane, without success, (Equation 51).

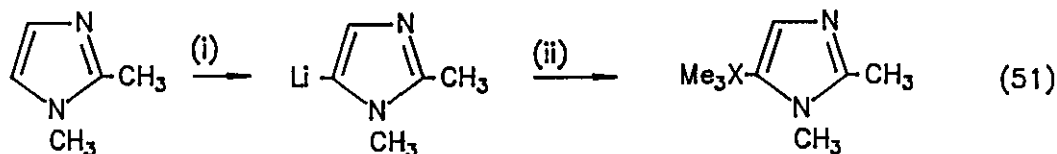

(i) BuLi/Et<sub>2</sub>O

(ii) Me<sub>3</sub>XCl, where X = Sn, Si

X = Sn (148); Si (149)

It was our intention to react the prepared trimethylstannyl- and trimethylsilylimidazoles with isoamyl nitrite to give 1,2-dimethyl-5-nitrosoimidazole (143), (Equation 52).

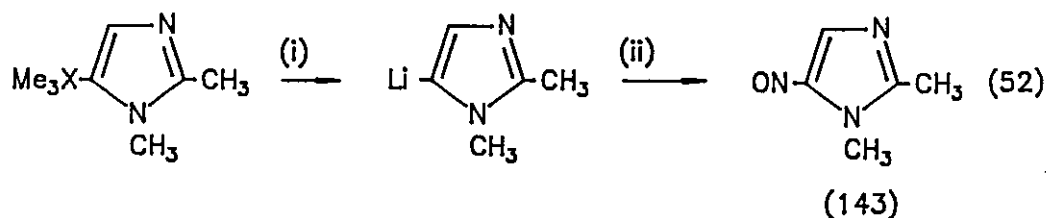

(i) BuLi/Et<sub>2</sub>O

(ii) C<sub>5</sub>H<sub>11</sub>ONO

The reason for our lack of success was not obvious, and time restrictions prevented us from pursuing an otherwise potentially promising synthetic route.

We were unable to prepare the Grignard (150) from 5-bromo-1,2-dimethylimidazole (111) and Mg/I<sub>2</sub> using ether or THF as solvent, which we hoped then to react with isoamyl nitrite to give the nitrosoimidazole (143), (Equation 53).

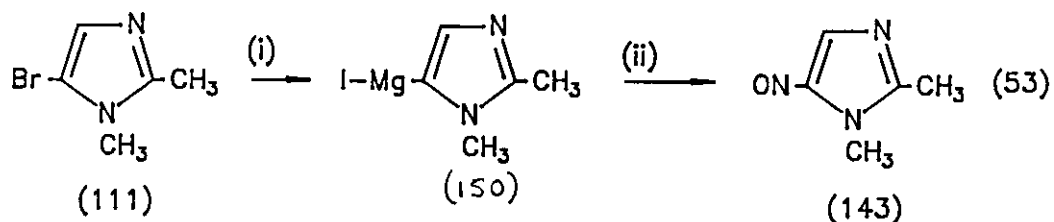

(i) Mg/I<sub>2</sub>/THF

(ii) C<sub>5</sub>H<sub>11</sub>ONO

Attempts to synthesise other nitrosoimidazoles by treating 2-phenylimidazole (151), 4(5)-methylimidazole (141) and imidazole (41) with NaOMe/MeOH/isoamyl nitrite, proved unsuccessful. The only products were typically dark



red/purple oils which were found by t.l.c. and  $^1\text{H}$  n.m.r. spectroscopic analysis to consist of many decomposition products. These unsuccessful preparations also indicate the apparent requirement of a suitable stabilising group at the C-4(5) position for this type of nitrosation.

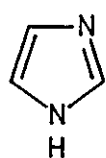

(41)

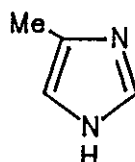

(141)

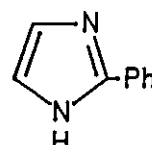

(151)

(c) Preparation of Nitroso-Heterocycles

A decision was made to synthesise some other nitroso-heterocycles in order to compare their behaviour with that of nitrosoimidazoles in subsequent model reaction studies. Reports of nitroso-heterocycles in the literature are few but several examples are reported in intermediates usually in purine syntheses,<sup>87-89</sup> (Equation 54).

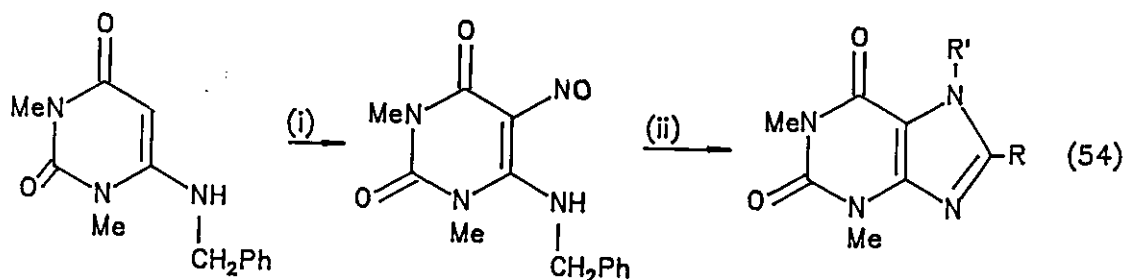

(i)  $\text{C}_5\text{H}_{11}\text{ONO}$

(ii) XYLENE/BuOH/HEAT

We attempted to synthesise several nitroso pyrroles by treatment with NaOMe/MeOH/isoamyl nitrite as described

previously. In the case of pyrrole-2-carboxaldehyde (152), pyrrole-2-carboxylic acid (153), and pyrrole (40) itself, after 14 days the reactions gave no sign of any nitrosated products.

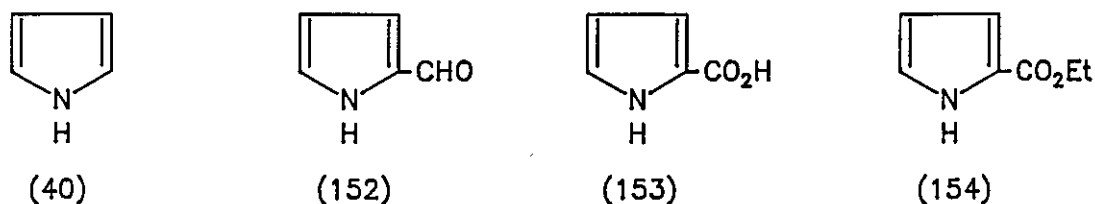

We believe that pyrrole-2-carboxylic acid (153) was unreactive because attack by  $\text{MeO}^-$  gives initially the carboxylate anion in preference to the anion at nitrogen. There must be a reluctance toward the formation of a double anion, (155), which therefore results in no further reaction even though we used 2 equivalents of  $\text{NaOMe}$ , (Equation 55).

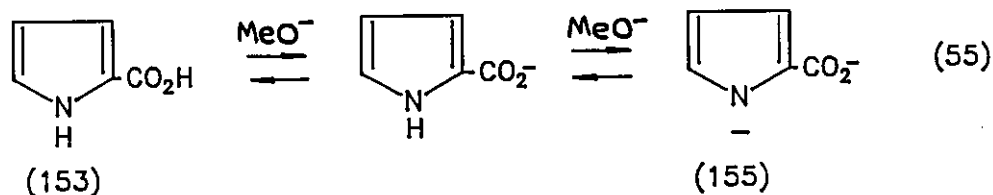

The  $-\text{CHO}$  and  $-\text{CO}_2\text{Et}$  groups in pyrrole-2-carboxaldehyde and pyrrole-2-carboxylic acid ethyl ester probably deactivate the pyrrole ring toward electrophilic substitution so that reaction cannot take place.

We believed that pyrrole itself, when nitrosated, would exist as the oxime (156) rather than the free nitroso form because of intramolecular H-bonding, (Equation 56).

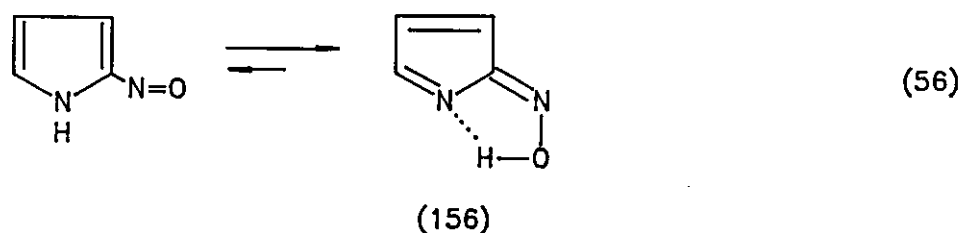

However neither the oxime or the free nitroso compounds were observed at any time during our investigations.

Nitrosation of 2,5-dimethylpyrrole gave signs of some green nitrosated material (157) on workup, as reported<sup>89</sup> but despite several repeated attempts, we were unable to prevent total decomposition of the product post reaction. The reaction method was the same as outlined earlier involving treatment with NaOMe/MeOH/isoamyl nitrite then subsequent acidification with gaseous CO<sub>2</sub>, (Equation 57).

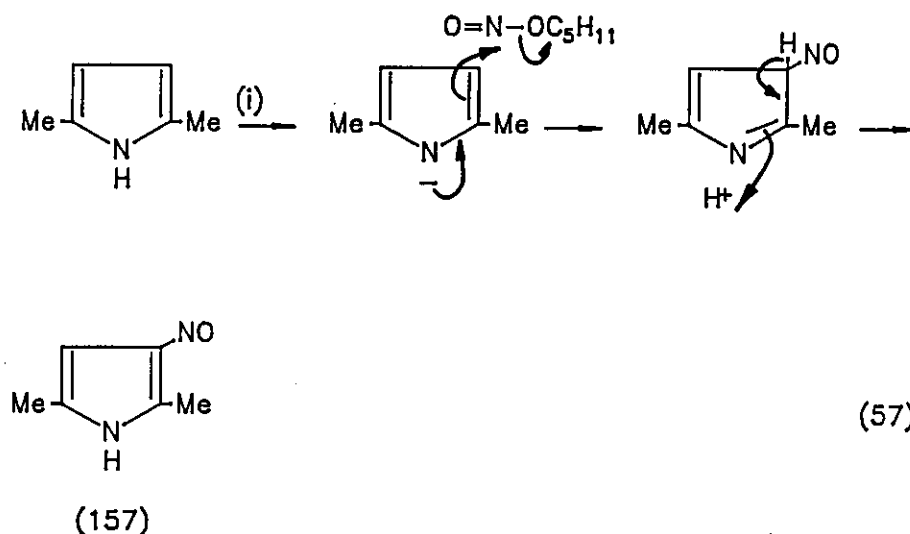

Two routes were employed in the synthesis of 1,2-dimethyl-3-nitrosoindole (158), 1-methyl-3-nitroso-2-phenylindole (159) and 1-methyl-3-nitrosoindole-2-ethylcarboxylate (160)

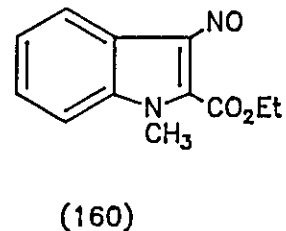
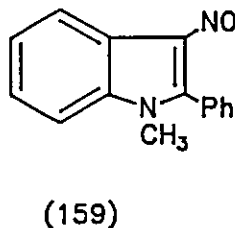
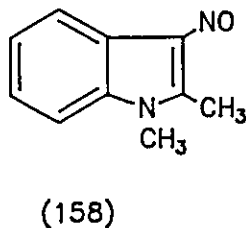

The initial approach was to N-methylate using KOH/dimethylsulphate as described by Heaney *et al*<sup>90</sup> followed by nitrosation with conc. HCl/NaNO<sub>2</sub> at -10°C, (Equation 58).

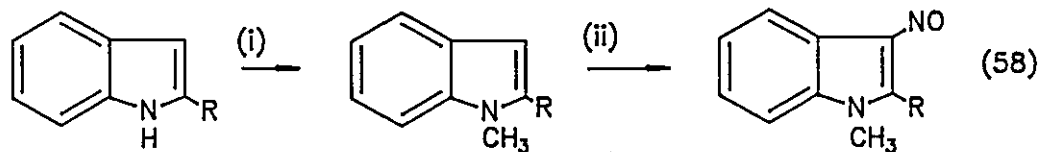

R = Me, Ph, CO<sub>2</sub>Et

(i) KOH/DMSO/CH<sub>3</sub>I

(ii) HNO<sub>2</sub>

The yields of the initial methylations were typically between 80 and 90%. The mechanism of the methylation involves the removal of the N-H proton by the naked, (non-solvated), OH<sup>-</sup>. Attack of methyl iodide by the resulting indole anion gives the N-Me compound, (Equation 59).

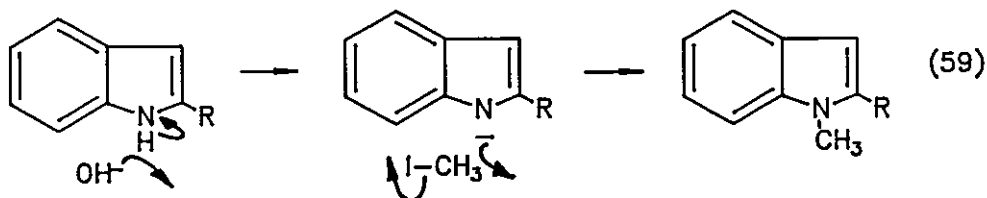

R = Me, Ph, CO<sub>2</sub>Et

The nitrosation stage involved the reaction of nitrous acid, (NaNO<sub>2</sub>/HCl), with the N-Me substrate at the temperature below 0°C. The reactions were typically allowed to run for up to 30 min, after which they were quenched with water and the precipitated crude product was separated by filtration. Purification was achieved by recrystallisation. The nitrous acid acts as a source of NO<sup>+</sup> which reacts with the more electron rich 5-membered ring of the indole at the only available position, C-3. The C-3 proton is then removed by base to restore aromaticity, (Equation 60).

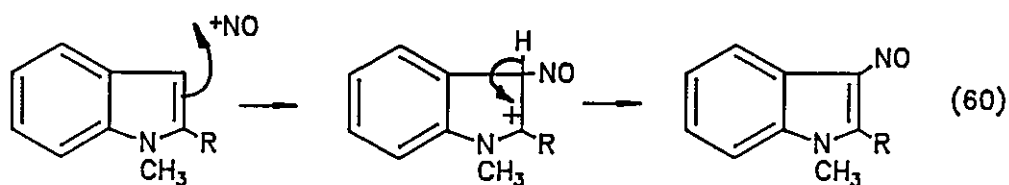

R = Me, Ph, CO<sub>2</sub>Et

Of the three indoles treated in this manner, (1,2-dimethyl-, 1-methyl-2-phenyl-, and 1-methyl-2-ethoxycarbonyl), only 1-methyl-2-phenylindole gave the nitrosated product as a green crystalline material. We assume that the reason for other indoles not reacting as expected is because the 2-substituent either did not activate the ring sufficiently toward electrophilic attack, (1,2-dimethylindole), or deactivated it, (1-methylindole-2-ethylcarboxylate)

The alternative route we adopted was to nitrosate the N-H form of the indole by treatment with MeOH/NaOMe/isoamyl-nitrite as reported in the literature,<sup>89</sup> then methylation of the resulting nitrosoindole would give the desired compounds, (Equation 61).

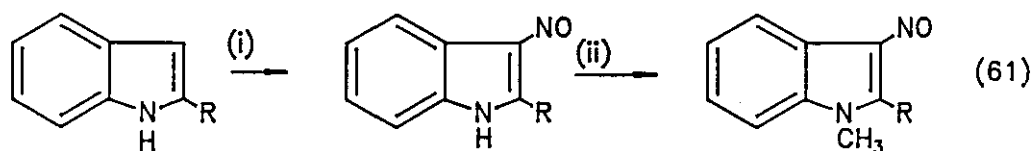

R = Me, PH, O<sub>2</sub>Et

(i) MeOH/Na; C<sub>5</sub>H<sub>11</sub>ONO

(ii) KOH/DMSO/CH<sub>3</sub>I

The 2-CO<sub>2</sub>Et group deactivated the indole toward electrophilic attack thereby preventing the nitrosation reaction taking place under the conditions we employed. When we

reacted 2-phenylindole with NaOMe/isoamyl nitrite an orange product resulted which was insoluble in organic solvents and water. Ultraviolet spectroscopic analysis did not show the presence of a nitroso group. Further spectroscopic analysis appeared to support the literature suggestion that product was in the oxime form (161).<sup>87</sup>

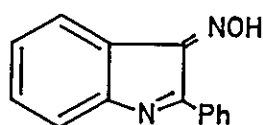

(161)

2-Methylindole gave virtually quantitative yields of a yellow crystalline material, which was soluble in polar organic solvents to give a green solution. It is believed that the compound exists in the dimeric form (162) as a solid but in solution as the free nitroso species (163), (Equation 62).

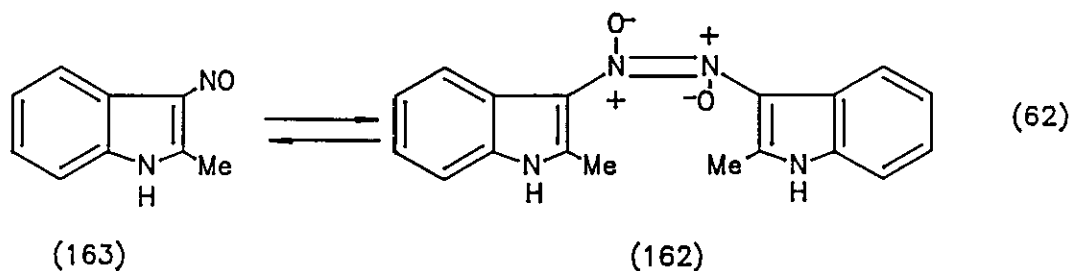

This supposition is supported by certain other nitroso compounds, (164), and by u.v. spectroscopic analysis of the compound in ethanolic solution.

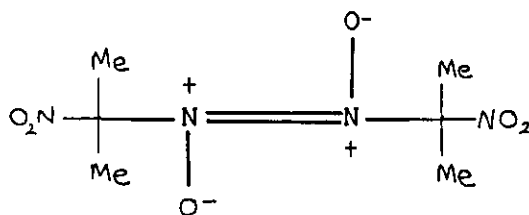

(164)

The second stage in the preparation involved reaction of the nitrosated species with KOH/DMSO/MeI as described earlier. The oxime form of the 2-phenyl compound did not give the expected 1-methyl-3-nitroso-2-phenylindole because the stable oxime does not have the N-H required for this reaction, (Equation 63).

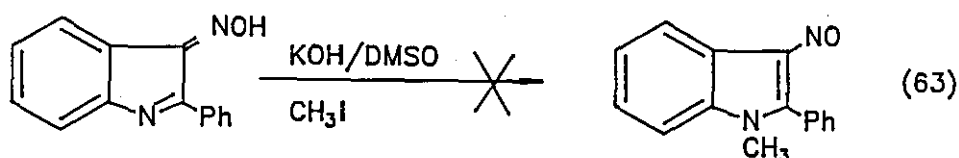

The 2-methyl-3-nitrosoindole gave an intense green solution, probably due to the anion of the free nitroso species (165), which changed to brown as the reaction progresses. The reaction yielded a brown gummy material which resisted any attempt to purify it. Analysis using a number of spectroscopic and chromatographic techniques indicated that there was no nitroso group present.

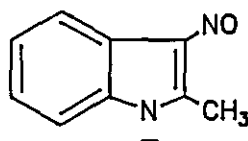

(165)

Due to lack of time, we were unable to pursue these reactions any further or to attempt the preparation of any other examples.

#### (d) Conclusions

It is clear that the preparation of nitrosated heterocycles is not as straightforward as it might at first appear. Their instability particularly toward acid precludes certain

synthetic routes, i.e. alkyl nitrites and acidic media. Reaction via a N-anion is apparently dependent on ring substituents either to activate the ring or, as is the case for imidazoles, to stabilise an intermediate in the reaction mechanism.

We were prevented from investigating further into what is clearly an area of interest by the limitations of time, and so only a small number of nitroso-heterocycles were prepared for use in model reactions designed to mimic possible reactions in the mechanism of action of nitroimidazole antibiotics.



### 3.3 ELECTRON SPIN RESONANCE (E.S.R.) SPECTROSCOPY OF NITROSOIMIDAZOLES

This thesis does not include an interpretation of the e.s.r. spectroscopy results but uses the interpretations and conclusion drawn by Professor Martyn C.R.Symons. The results obtained are shown in Table 4 and are shown for reference only.

COMPOUND	SOLVENTS	NUCLEUS	A/G <sup>a</sup>		
			A <sub>  </sub>	A <sub>⊥</sub>	A <sub>iso</sub> <sup>b</sup>
4(5)-Nitroso-5(4)-phenylimidazole (137)	CD <sub>3</sub> OD	<sup>14</sup> N	26.5	≤ 7	8.8
	MeTHF		25	≤ 7	8.3
1-Methyl-5-nitroso-4-phenylimidazole (37)	CD <sub>3</sub> OD	<sup>14</sup> N	25	≤ 7	8.8
	MeTHF		24.5	≤ 7	8.2
(PhNO) <sup>-</sup> c (158)	CD <sub>3</sub> OD	<sup>14</sup> N	26	< 7	~8.1
	MeTHF		26	≤ 7	~8.1

Table 4: e.s.r. spectroscopic data for the nitrosoimidazole radical anions

a 1 G = 10<sup>-4</sup> T.

b Using A ≈ 0 which is normal for  $\pi$ -radicals.

c 3 H (ave) ≈ 3.8 G [A<sub>iso</sub> = 7.90 G and 4H = 2.90, 2.983 (o), 1.01 (m), and 3.90 (p)].

A<sub>||</sub> parallel hyperfine coupling constant

A<sub>⊥</sub> perpendicular hyperfine coupling constant

A<sub>iso</sub> isotropic hyperfine coupling constant

Earlier in this thesis, we discussed the reduction intermediates between the nitroimidazole and the amine end product, (Equation 64).

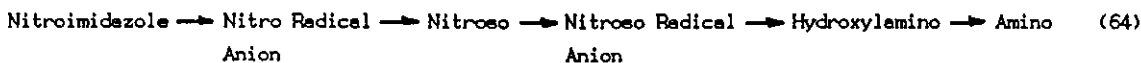

We initially discounted the nitroso radical anion as a potential reactive intermediate on the grounds that it would probably be a highly unstable species which would not have a sufficiently long half life. The two nitrosoimidazoles, (37 and 137), were examined using e.s.r. spectroscopy, (Table 4), as no data for nitrosoimidazole radical anions could be found in the literature. Our preliminary results have been accepted for publication.<sup>91</sup>

Contrary to our expectations, the nitrosoimidazoles gave stable radical anions at 77 K. The radical anions are of the theoretically predicted  $\pi$ -type consistent with having a  $-N=O$  unit coplanar with the ring, (cf.  $\text{PhNO}^{\cdot-}$ ).<sup>92,93</sup> The results indicate that in both the 4- and 5-nitrosoimidazoles, 39% of the radical character is associated with the nitroso N atom. By comparison, in 4- and 5-nitroimidazole radical anions, ~50% of the spin density is situated on the nitro N atom.<sup>34</sup>

The unexpected stability of the nitroso radical anion indicates that it is a potential reactive intermediate in the mechanism of action on the antimicrobial activity and the radiosensitisation in chemotherapy of nitroimidazoles. Unfortunately, we were unable to further investigate the nitroso radical anion as a possible intermediate. We believe, however, that this is an area which requires more detailed study.

### 3.4 REACTIONS OF NITROSO-HETEROCYCLES

#### (a) Background

In order to investigate the potential of the nitroso-imidazole as the reactive intermediate in the mechanism of action of nitroimidazole antibiotics, we devised some model reactions. These reactions were intended to mimic those which could possibly occur in the target organism but be suitable for carrying out on the bench.

As has already been mentioned in this thesis, DNA is the most commonly postulated site of attack in the target cell. Disruption of the DNA helix or to the replication process would result in the death of the organism. Therefore, the reaction need not necessarily be particularly complex to achieve the desired result.

The primary amino groups present in all of the nucleosides in DNA, except thymidine, represent a possible site of attack by the nitroso reactive intermediate. The mechanism by which primary aromatic amines and nitroso compounds react is known as the Mills reaction,<sup>94</sup> which results in the formation of a diazene, (Equation 65).

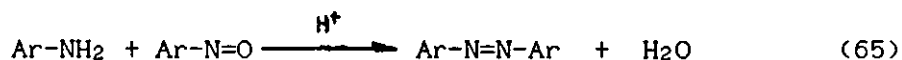

Diazene

The reaction requires acid catalysis and can be thought of as similar to that between an aldehyde and amine which results in the formation of a Schiff's base, (Equation 66).

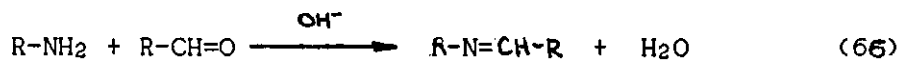

Schiff's base

Subsequent work,<sup>95</sup> has shown that the reaction can also be performed in the presence of base in certain circumstances,

(Equation 67).

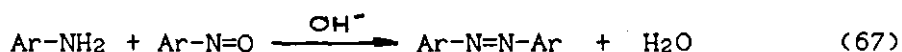

An alternative reaction site is with one of the various thiol species present in the target organism. One such type of thiol are the repair enzymes which are responsible for repairing the damage caused by foreign materials, including antibiotics, without which would result in the disruption of the DNA leading to cell death. Glutathione (31) is responsible for maintaining a reduced level of thiols in living cells, and if depleted by reaction with the nitrosoimidazole then damage can occur. Other thiol species are present in the cell, cysteine (166) for example, as well as sulphur containing compounds, one of which is the enzyme ferredoxin oxireductase responsible for the reduction of the nitroimidazole in the cell.

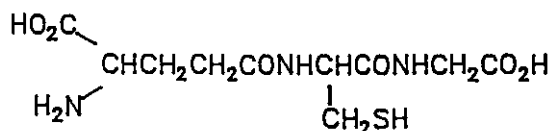

(31)

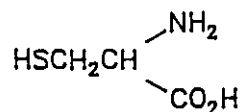

(166)

Our approach was to model the possible reactions between cellular thiols or primary amine sites with nitrosoheterocycles using initially very simple analogues to establish suitable conditions as a precedent for later reactions between more realistic models or even the biological fragments themselves.

We do not claim that the reactions we have chosen to examine are the only possible ones, simply the most probable in our opinion. With this in mind, what follows is necessarily limited by the restriction of time.

(b) Reactions between nitroso compounds and primary aromatic amines

Our initial studies involved repeating certain literature reactions reported by Mills<sup>94</sup> using more modern techniques where required.

The most simple example of a reaction between aromatic nitroso and aromatic primary amino compounds was that between nitrosobenzene and aniline to give diphenyl diazene (167), (Equation 68).

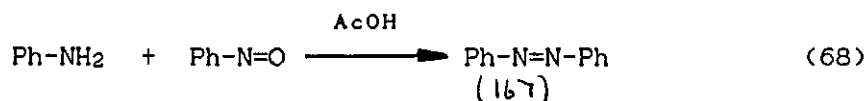

The reaction was performed in glacial acetic acid at 0 to 5°C and gave the diazene in virtually quantitative yield. Nitrosobenzene and *p*-toluidine were reacted under identical conditions to yield 1-phenyl-2-(*p*-tolyl)diazene (168) also in very high yields.

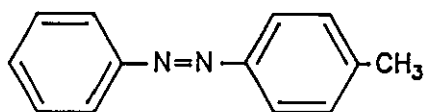

(168)

We adapted the original method of Mills,<sup>94</sup> in which acetic acid was used as the reaction medium, by substituting ethanol as solvent with just traces of acetic acid as a catalyst. The reaction times achieved were longer than with only acetic acid but yields were still high. This seemed to indicate that the reaction was indeed acid catalysed and analogous to the formation of a Schiff's base.

When 4(5)-nitroso-5(4)-phenylimidazole was reacted with *p*-

toluidine in the presence of traces of acetic acid we were unable to detect any species which contained a diazene functional group, as determined by u.v. spectroscopy, (Equation 69).

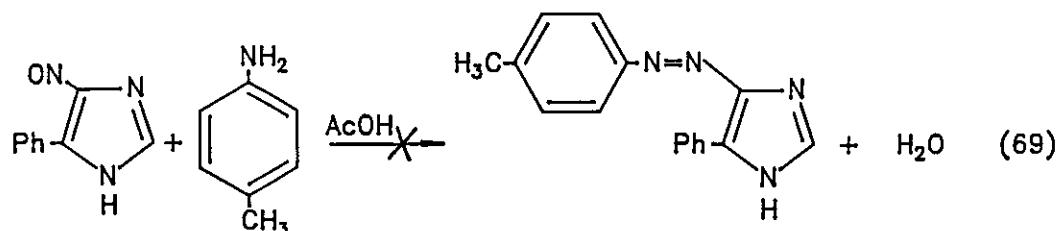

Despite repeated attempts, nitrosobenzene when reacted with 9-benzyladenine (169), (formed by the benzylation of adenine),<sup>96</sup> gave no species containing a diazene functional groups, (Equation 70).

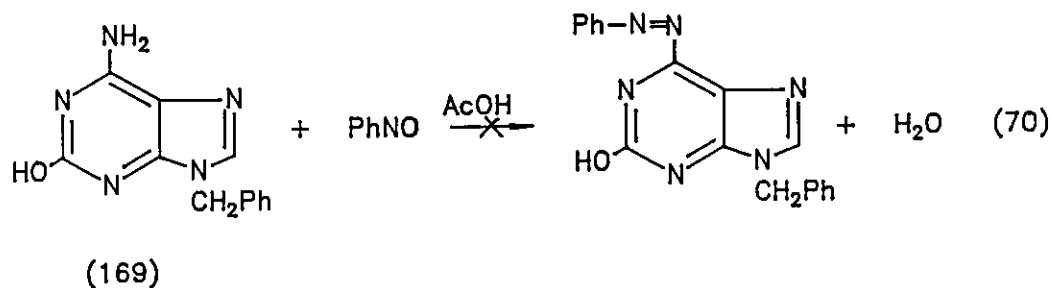

At this stage, we wondered whether the models we had chosen were really close enough to the actual molecules involved. We therefore looked to 2- and 4-amino pyridines, (170 and 171), which contain a similar arrangement of functional groups to those in nucleoside bases, such as adenine.

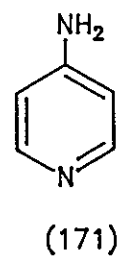
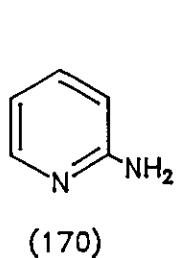

All attempts to promote a coupling reaction in acidic conditions between aminopyridines and nitroso compounds were unsuccessful. Reports in the literature,<sup>95</sup> indicated that such reactions were possible in basic media. Protonation of the amino groups of the aminopyridines unlike the amines used previously, results in structures which prevent further reaction as required.

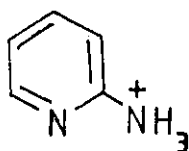

Reaction involved treatment of the amino and nitroso species with 50% aqueous NaOH solution at 50°C with traces of toluene to aid the dissolution of the reactants. Vigorous stirring or shaking was employed to ensure maximum contact between the two phases. The products were isolated from the toluene phase by evaporation to dryness under reduced pressure followed by column chromatography and recrystallisation where required.

We believe that the reaction in basic conditions resembles that in the Aldol condensation, involving attack of the nitrogen of the nitroso group by the amino lone pair of the amine. The OH<sup>-</sup> facilitates the removal of a proton by the elimination of water. Subsequent loss of water gives the diazene, (Scheme 28).

We can see that the electropositive nitrogen of the -N=O group resembles that of the carbon atom of the >C=O group in the aldol condensation, (Scheme 29).

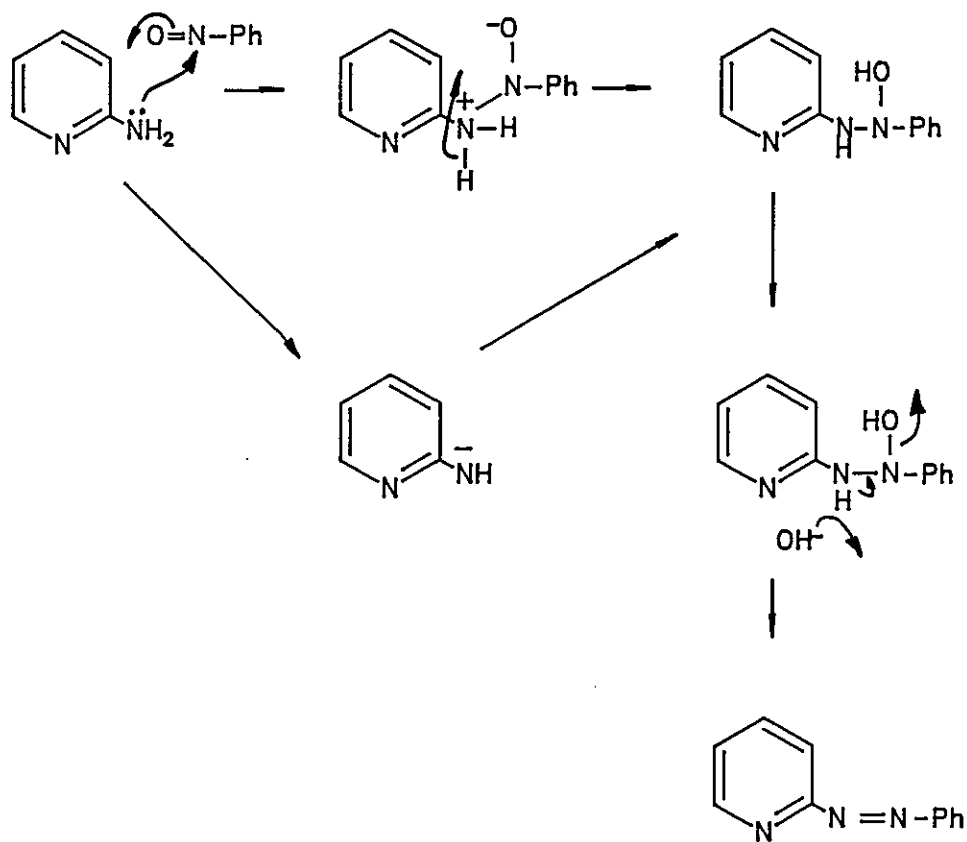

Scheme 28

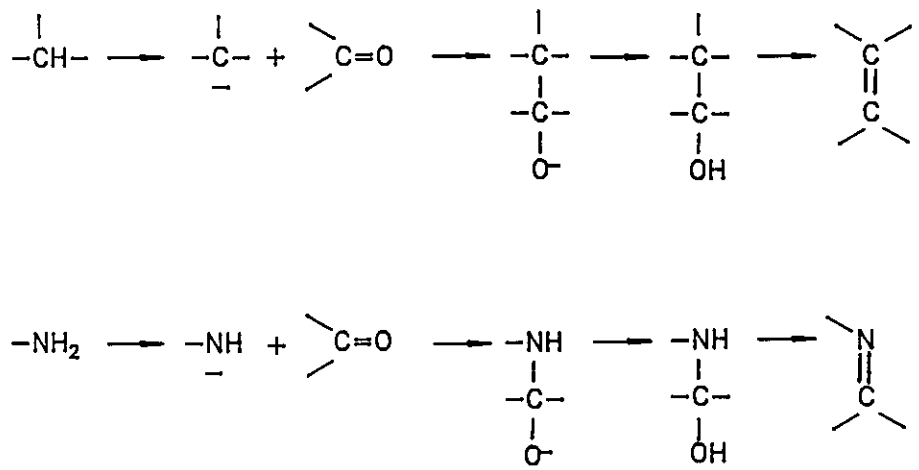

Aldol Condensation

Scheme 29



The diazenes resulting from the condensation of nitrosobenzene, 2-aminopyridine, (172) and 4-aminopyridine, (173), are red solids which were produced in moderate yield.

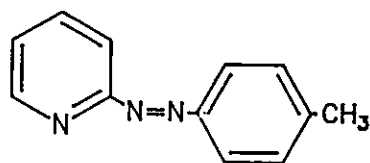

(172)

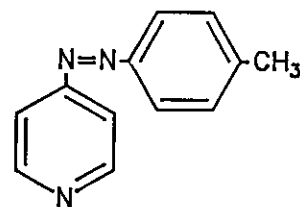

(173)

Reaction between 4(5)-nitroso-5(4)-phenylimidazole and aminopyridines under basic conditions gave no products which contained the -N=N- functional group, as determined by u.v. spectroscopy. We were unable to react 4(5)-nitroso-5(4)-phenylimidazole with *p*-toluidine or 9-benzyladenine to give the respective diazenes (174, 175).

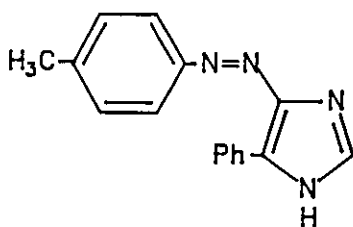

(174)

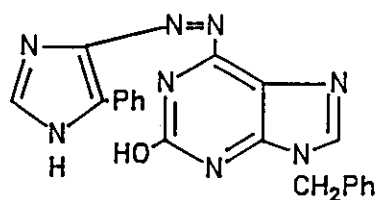

(175)

In all of the reactions we attempted between nitrosoimidazoles and aromatic primary amines we did not observe any species containing the diazene functional group despite in many cases the production of orange/red coloured by-products which we were unable to identify. These products we believe to be dimers and polymers formed by the interaction of nitrosoimidazoles and related reduction

products.

(c) Reactions between Nitroso-Heterocycles and Thiols

For reasons of easy handling, we chose *p*-chlorothiophenol (176) for our initial model for reactions between cellular thiols and the nitroso intermediate in the reduction of nitroimidazoles. Reactions between nitroso intermediates and cellular thiols such as glutathione (31), have been suggested as possible reactions in the mechanism of action of nitroimidazole antibiotics,<sup>30</sup> although the details of the reactions involved, to our knowledge, have not been reported.

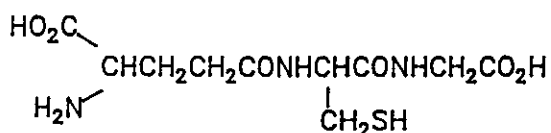

(31)

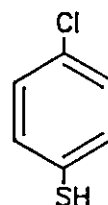

(176)

Ehlaradt and co-workers<sup>39</sup> reported that reactions between 4(5)-nitroso-5(4)-phenylimidazole and water or methanol gave adducts resulting from a reaction at the 2-position of the imidazole ring. In the case of the water, the adduct (177) rapidly degrades by ring fragmentation although the methanol adduct (178) is reported as an isolable and relatively stable species, (Scheme 30).

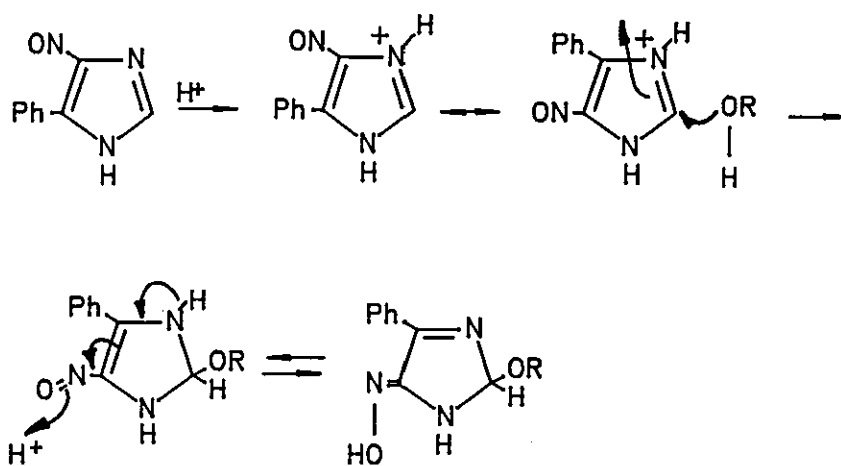

R = H (177)

R = Me (178)

Scheme 30

We believed that these reactions were possibly applicable to other nucleophiles such as thiols and so provided a potential reaction mechanism for reduced nitroimidazoles, (Equation 71).

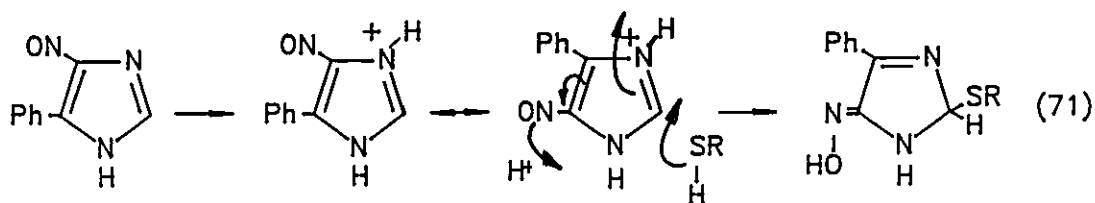

We repeated the methanol reaction as reported by Ehlar *et al* 39 where 4(5)-nitroso-5(4)-phenylimidazole was maintained in anhydrous methanol and sealed under an atmosphere of nitrogen for 7 days. During the reaction time the free nitrosoimidazole gradually dissolved to give a golden-brown solution. The methanol was removed under reduced pressure to give a brown solid which proved to be the predicted methanol

adduct (178).

p-Chlorothiophenol (176) was reacted together with the nitrosoimidazole (137) in ether, THF or anhydrous methanol. The nitrosoimidazole was partially soluble in ether or THF and reaction was deemed to be complete when no starting material was visible, solution being achieved as the nitrosoimidazole reacted and went into solution. Reactions in THF were quicker due to the increased solubility of the nitrosoimidazole. Monitoring the progress of the reactions by t.l.c. showed the appearance of many coloured species along with one major new spot.  $^1\text{H}$  N.m.r. spectroscopic analysis indicated none of the expected imidazole-thiol adduct but what we presumed was the disulphide (179) resulting from the dimerisation of the thiol. No trace of any imidazole species (180) could be observed or isolated.

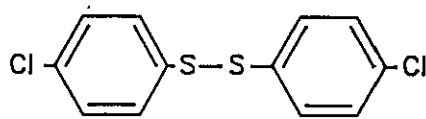

(179)

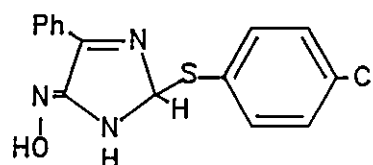

(180)

It was decided that we should use a different thiol, one which more closely resembled the biological thiols, such as cysteine, with regards to pKa and structure. We chose ethyl 2-mercaptoacetate (181) for these reasons in addition to which identification by  $^1\text{H}$  n.m.r. analysis was more straightforward. The disulphide was prepared by iodine oxidation of the thiol to act as a sample for authentic comparison purposes.

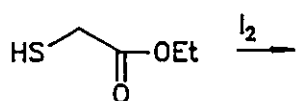

(181)

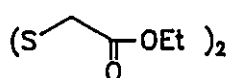

(182)

(72)

Reactions as before in a number of solvents gave no imidazole-thiol adduct at the 2-position but gave high yields of disulphide (182). N.m.r. spectroscopic analysis using an internal standard showed yields between 50 and 80% depending on reaction time. In methanol solution reactions typically took less than 1 h indicating the rapid nature of the process. Attempts to halt the reaction after a few minutes resulted in reduced yields of disulphide but no imidazole-thiol adduct (183). Reactions allowed to run for several days indicated the presence of some small quantities of the methanol adduct (178) in addition to the disulphide. In all cases, the imidazole starting material was consumed apparently by ring opening reactions as was observed in the reaction with water<sup>39</sup> (Equation 73).

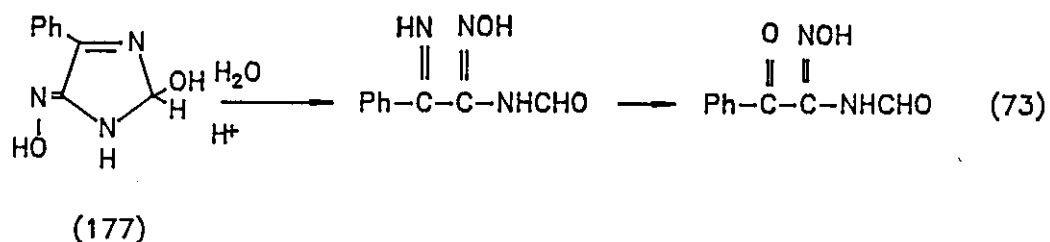

Our attention shifted to the reactions between 1-methyl-5-nitroso-4-phenylimidazole (37), a closer analogue to commercial N-alkylated nitroimidazoles, and the two thiols described. Similar reactions were carried out with identical products being formed although the reactions were more rapid, due in part to the greater solubility of the N-methyl compound compared with the N-H one. Disappointingly, at no stage did we observe the formation of any adduct (184) resulting from reaction at C-2. Our observation that some methanol adduct was formed when long reaction times were employed seems to rule out the possibility of a similar reaction with thiols.

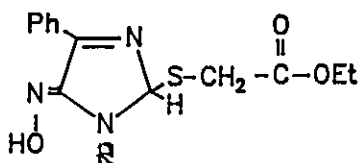

R = H (163) ; R = Me (184)

Thiols are much stronger nucleophiles than methanol and would be expected to react much more rapidly, but our observation that with long reaction times some methanol adduct is produced indicates that no such reaction between thiols and nitrosoimidazoles is possible. We do not fully understand why thiols do not react in the same way as nucleophiles like water or methanol do, but this is clearly the case.

The obvious explanation is that s.e.t. between thiolate anions and nitrosoimidazoles is very much faster than nucleophilic addition at C-2. S.e.t. is not possible with water and methanol. Even if water and methanol could be ionised, the s.e.t. would be most unfavourable.

From the results obtained we can see that the nitrosoimidazole acts as an oxidising agent, converting thiol to disulphide in almost quantitative yields. Our yields were below the maximum because we terminated the reactions before the last traces of starting material were consumed.

The redox reaction is most likely to proceed via the thiolate anion rather than the thiol. Thiols readily deprotonate with weak bases (nitrosoimidazoles), or are in equilibrium at neutral pH. We suggest that the key reaction is a s.e.t. between the nitrosoimidazole and thiolate anion, (Scheme 3').



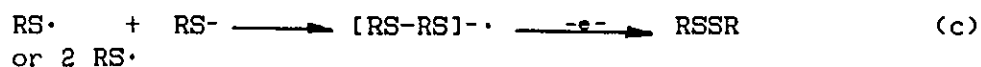
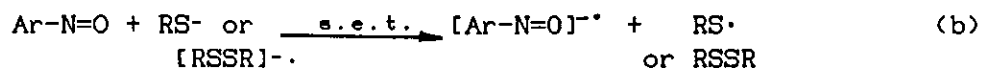

$^\cdot$  or some other species from the reduction  
 Ar-N=O 1-methyl-5-nitroso-4-phenylimidazole (37).

Scheme 31

A possibility is that the protonated nitrosoimidazole (185), is involved in the redox reaction, (Scheme 32).

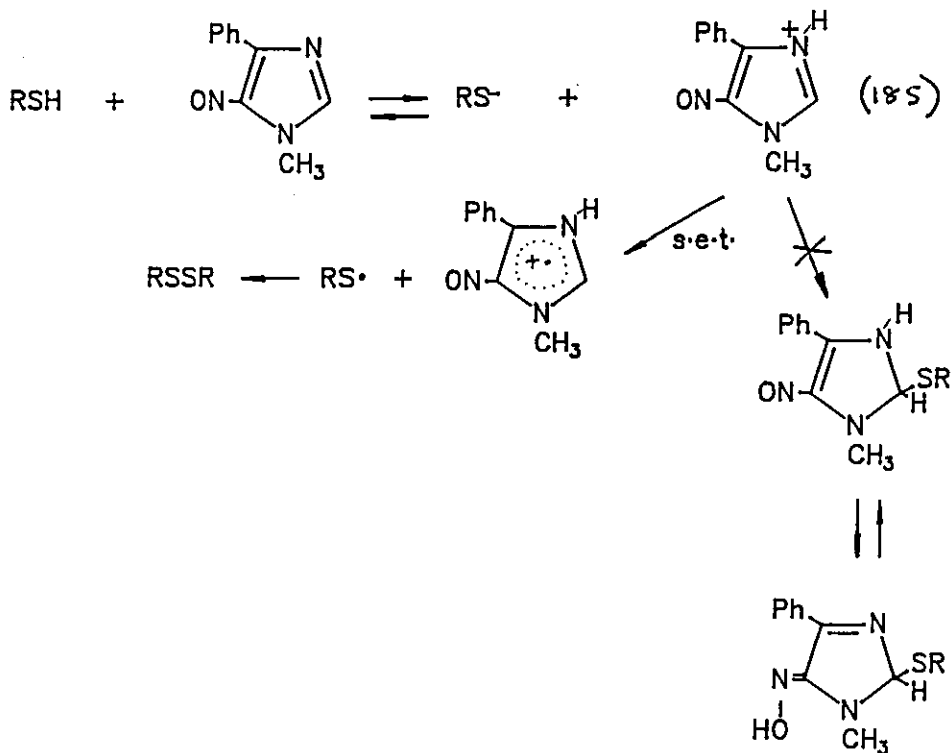

Scheme 32

We used 2-methyl-3-nitrosoindole (163) to see whether the observed oxidation behaviour was restricted to nitrosoimidazoles or whether it could be said to apply to nitrosoheterocycles as well. Under the same conditions the nitrosoindole (163) gave about 50% yields of the disulphide (182) when allowed to react with ethyl 2-mercaptoacetate. We also observed that the reaction times required to achieve

comparable yields of disulphide were several times longer than for the nitrosoimidazoles tested. As for the imidazoles, the indole was completely destroyed during the reaction and we were unable to discover any species containing an intact indole ring system.

Unfortunately, we were unable to test any further nitroso heterocycles to examine the extent of this reaction mechanism. We believe that the heterocyclic ring system acts as a convenient carrier for a nitroso group and that it is the nitroso group that facilitates the oxidation of thiol to disulphide. The implications of this are that if the reaction between nitroso species and cellular thiols is either the or a major reaction in the mechanism of action of nitroimidazole antibiotics, then it may be possible to design nitroso compounds which have greater antimicrobial efficacy. The imidazole ring would appear to be efficient as a transporter of nitroso groups to the reactive site in the cell, more so than indoles. This probably results from the peculiar amphoteric properties of the imidazole ring system. Such activity of nitroimidazoles towards anaerobic organisms, the reduction potential in aerobic cells being insufficient to reduce the nitroimidazole to the nitroso intermediate. Also the reports that 4- and 5-nitrosoimidazoles are equally biologically active towards anaerobic micro-organisms whereas 4-nitroimidazoles are almost totally inactive, a consequence of the higher reduction potential of 4-nitroimidazoles in comparison with 5-nitroimidazoles.

(d) Other reactions of nitroso heterocycles

We were unable to carry out many other reactions with nitroso-heterocyclic substrates in addition to those already detailed. Reactions between acetylcysteine (186) and the nitroso compounds described led to the formation of the



disulphide of acetylcysteine (187), (Equation 74).

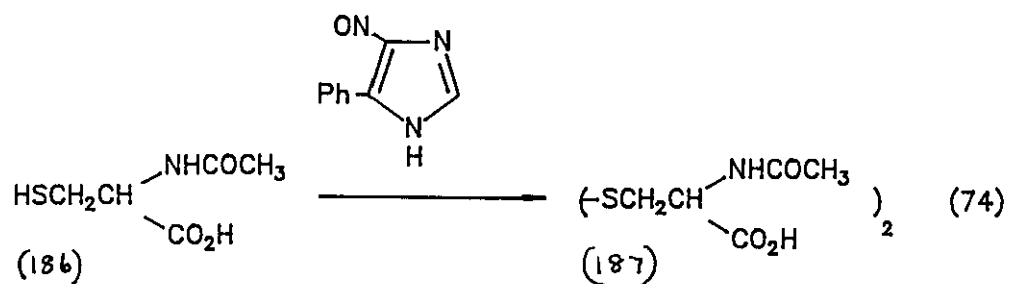

We attempted to react 2-hydroxypyridine (188) with 1-methyl-5-nitroso-4-phenylimidazole in anhydrous methanol as an example which contained both amine and hydroxyl sites. Unfortunately the sole product was the keto form of the hydroxypyridine (189), (Equation 75).

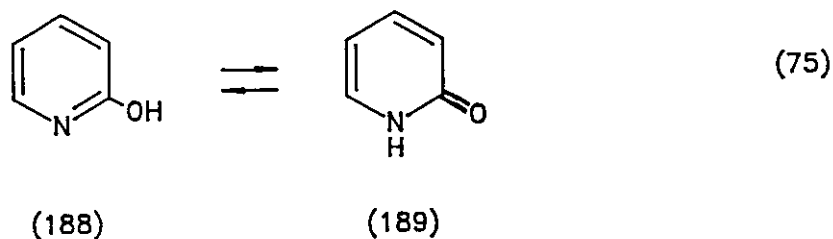

### 3.5 CONCLUSIONS

We believe that we have increased the knowledge concerning nitrosoimidazoles with regards to their reactivity. It is clear that the nitroso intermediate in the reduction of nitroimidazoles is a viable species and that it does react rapidly with certain cellular compounds, (cellular repair thiols), irreversibly to prevent them from fulfilling their normal maintenance functions.

Whether this reaction is the crucial one in the mechanism of nitroimidazoles which leads to cell death by preventing the repair of normal damage to DNA, or whether it is merely an indication of the nature of the defence mechanism is unclear. If it is the latter, it is still an important biological mechanism which by itself leads to greater understanding of the repair processes in the cell. If, however, it is the former, then we can use the knowledge to design novel, different, and possibly more effective antibiotics which may have more widespread applications for the treatment against anaerobic organisms.

## CONCLUSION

When we began investigating the mechanism of action of nitroimidazole antibiotics, there were several possible reactive intermediates postulated.<sup>24,33,32,39</sup> All of the species proposed as potential reactive intermediates were reduction products of the parent nitroimidazole drug, as reduction is known to be an essential factor in the mechanism of action.

The nitroimidazole radical anion, being the initial reduction species, was, we believed, the most likely candidate. Our limited studies indicated that far from being a short lived, unstable species, the nitroimidazole radical anion is remarkably stable. Nitroimidazole radical anions have been shown to survive the severe conditions in electron spin resonance spectroscopy, and not react with DNA as initially suspected.<sup>56</sup>

Under various reductive conditions known to proceed by radical interactions, we were unable to react DNA models with the nitroimidazole radical anion. The sole outcome of all attempts to trap nitroimidazole radical anions was the production of a large number of highly coloured reduction species which were themselves unstable and were not isolated. Under fairly vigorous conditions, Crozet and co-workers<sup>50</sup> successfully reacted nitroimidazole radical anions with the anion of 2-nitropropane at the C-4 position. This result was surprising as e.s.r. spectroscopic measurements<sup>34</sup> indicated 20% of the radical character of the radical anion to be associated with the C-4 position, whereas 80% is located on the nitro group.

A proposed dissociation of the nitroimidazole radical anion to give nitrite anion and the potentially reactive 5-imidazolyl radical,<sup>13,35</sup> whilst improbable, was extensively investigated. The 5-imidazolyl radicals were generated by

reduction of the analogous 5-halogenoimidazoles under radical conditions. The successful trapping of 5-imidazolyl radicals both inter- and intra-molecularly demonstrated the feasibility of such radicals as reactive intermediates.<sup>73</sup> E.s.r. spectroscopic analyses of several halogenoimidazoles showed them to be unusual  $\sigma^*$  radicals and not the expected  $\pi^*$  radicals.<sup>72</sup> Moreover, the halogenoimidazole radical anions were relatively stable under e.s.r. spectroscopic conditions, thus making dissociation of the more strongly bonded nitroimidazole radical anion even less likely.

Under forcing conditions, attempted SRN1 reactions with halogenoimidazoles were unsuccessful. This would seem to indicate that under the much milder conditions within the cell, reaction between nucleophiles and the less reactive nitroimidazole radical anion is unlikely as a possible mechanism of action.

Although the nitroimidazole radical anion has not been totally eliminated as a potential reactive intermediate, it has come to appear more improbable.

Published evidence<sup>24,32</sup> indicates that the hydroxylamino and amino reduction intermediates are not the reactive species responsible for the observed biological activity of nitroimidazoles. Our attention was therefore drawn toward the nitroso intermediate as a possible reactive species. What little published information concerning nitrosoimidazoles indicated that they were highly reactive, hence the lack of available data, and that they were more potent antibacterial agents than the corresponding nitro analogues.<sup>39</sup>

Our studies with selected nitrosoimidazoles<sup>91</sup> has shown that they are oxidants capable of oxidising thiols to the corresponding disulphides. It is clear that a reaction between nitroso intermediates and cellular repair thiols such as glutathione is a possible mechanism of action

although the great excess of thiol and the lack of specificity of such a reaction make it appear unlikely as the major reaction mechanism. More likely is that the reaction shows how repair thiols eradicate foreign compounds, such as nitrosoimidazoles in the cell.

Work with other nitroso-heterocycles such as nitrosoindoles, has demonstrated that they behave similarly to nitrosoimidazoles in their reactions with thiols. The suggestion is that the imidazole ring is merely an efficient carrier of a reactive site, the nitroso group, and other carrier species might be as or more effective. Further evidence in support of this suggestion comes from the observation that whereas the reduction potential of the biologically inactive 4-nitroimidazole is greater than that of the 5-nitroimidazole, their radical anions are virtually identical.<sup>34</sup> The initial reduction step is therefore almost certainly the rate determining one, after that the 4- and 5-isomers are essentially identical. In addition, 4- and 5-nitrosoimidazoles display equivalent biological activities.<sup>39</sup>

Although we have been unable to isolate a single specific reaction which could be said to represent the mechanism of action of nitroimidazole antibiotics or reactive intermediate responsible, we have given a focus for further investigation and, with the reactions involving thiols, possibly opened the way for the development of a new class of nitroso-heterocycle antibiotics.

## EXPERIMENTAL

### INDEX OF EXPERIMENTS

#### SECTION 1 - General Procedures and Instrumentation.

- (a) I.R.
- (b) N.M.R
- (c) Electrochemical Reduction
- (e) Melting Points
- (f) M.S.

#### General Procedure of e.s.r. Spectroscopic Analyses

#### Solvent Drying Procedures

- (a) Ethanol/Methanol
- (b) Diethyl Ether
- (c) THF
- (d) Acetone
- (e) Pyridine
- (f) DMF
- (g) Toluene
- (h) DMSO
- (i) Ammonia

#### SECTION 2 - Preparation of Nitroimidazoles

- 1 4(5)-Nitroimidazole
- 2 5(4)-Methyl-4(5)-nitroimidazole
- 3 1-Methyl-3-nitroimidazole
- 4 Diazomethane
- 5a 1-Methyl-5-nitroimidazole
- 5b 1-Methyl-5-nitroimidazole
- 6 1,5-Dimethyl-4-nitroimidazole
- 7a 1,4-Dimethyl-5-nitroimidazole
- 7b 1,4-Dimethyl-5-nitroimidazole
- 8 1,2-Dimethyl-5-nitroimidazole
- 9 Allyl *p*-toluenesulphonate (attempted)
- 10 Allyl *p*-toluenesulphonate

- 11 1-Allyl-2-Methyl-5-nitroimidazole
- 12 1-(But-3-en-1-yl)-p-toluenesulphonate
- 13 1-(But-3-en-1-yl)-2-methyl-5-nitroimidazole
- 14 1-Methyl-2-thiomethylimidazole
- 15 1-Methyl-5-nitro-2<sup>thio</sup>-methylimidazole
- 16 1-Methyl-2-methylsulphonyl-5-nitroimidazole
- 17 Methylthiocarbamoylpyrrolidine
- 18 **S**-Methyl derivative of methylthiocarbamoylpyrrolidine
- 19 1-Methyl-2-(1-pyrrolidino)imidazole
- 20 1-Methyl-5-nitro-2-(1-pyrrolidino)imidazole

SECTION 3 - Reduction Reactions of Nitroimidazoles using  
Sodium Dithionite as Reductant

General Method for Sodium Dithionite Reactions.

- 21a 1-(But-3-en-1-yl)-2-methyl-5-nitroimidazole
- 21a 1-(But-3-en-1-yl)-2-methyl-5-nitroimidazole
- 21c 1-(But-3-en-1-yl)-2-methyl-5-nitroimidazole
- 22a 1,2-Dimethyl-5-nitroimidazole/Thymine
- 22b 1,2-Dimethyl-5-nitroimidazole/Thymine
- 22c 1,2-Dimethyl-5-nitroimidazole/Thymine

SECTION 4 - Electrochemical Reduction of Nitroimidazoles

General Procedure for Electrochemical Reduction

- 23 1,2-Dimethyl-5-nitroimidazole
- 24 1,2-Dimethyl-5-nitroimidazole/Thymine
- 25 1,2-Dimethyl-5-nitroimidazole/Thymidine
- 26 1,2-Dimethyl-5-nitroimidazole/Cytosine
- 27 1,2-Dimethyl-5-nitroimidazole/Guanosine
- 28 1,2-Dimethyl-5-nitroimidazole/Adenine
- 29 1,2-Dimethyl-5-nitroimidazole/Cysteine
- 30 1-Allyl-2-methyl-5-nitroimidazole
- 31 1-(But-3-en-1-yl)-2-methyl-5-nitroimidazole

SECTION 5 - Preparation of Halogenoimidazoles

- 32 2,4,4,6-Tetrabromocyclohexa-2,5-dienone
- 33 4-Bromoimidazole

- 34 2,4,5-Tribromoimidazole
- 35 4-Bromoimidazole
- 36 4,5-Dibromo-2-methylimidazole
- 37 4-Bromo-2-methylimidazole
- 38 4(5)-Bromo-1,2-dimethylimidazole
- 39 5-Bromo-1,2-dimethylimidazole
- 40 5-Bromo-1,2-dimethylimidazole
- 41 4,5-Dibromo-1,2-dimethylimidazole
- 42a 1-Allyl-5-bromo-2-methylimidazole
- 42b 1-Allyl-5-bromo-2-methylimidazole
- 43 5-Bromo-1-(but-3-en-1-yl)-2-methylimidazole
- 44 5-Bromo-1-(but-3-en-1-yl)-2-methylimidazole
- 45 4,5-Di-iodo-2-methylimidazole
- 46 4,5-Di-iodo-1,2-dimethylimidazole
- 47 4-Iodo-2-methylimidazole
- 48 1,2-Dimethyl-5-iodo-imidazole
- 49 1-Allyl-5-iodo-2-methylimidazole (attempted)

SECTION 6 - Reduction Reactions of Halogenoimidazoles  
using Tributyltin Hydride as Reductant

General Procedure for Tributyltin Hydride Reactions

- 50a 5-Bromo-1,2-dimethylimidazole
- 50b 5-Bromo-1,2-dimethylimidazole
- 50c 5-Bromo-1,2-dimethylimidazole (Inhibition Study)
- 50d 5-Bromo-1,2-dimethylimidazole (Inhibition Study)
- 51 1,2-Dimethyl-5-iodo-imidazole
- 52 5-Bromo-1-(but-3-en-1-yl)-2-methylimidazole
- 53 1-Allyl-5-bromo-2-methylimidazole
- 54 1,2-Dimethyl-5-nitroimidazole

SECTION 7 - Reduction Reactions of Halogenoimidazoles  
using Sodium/Liquid Ammonia as Reductant

General Procedure for Sodium/Liquid Ammonia Reactions

- 56 5-Bromo-1,2-dimethylimidazole
- 57 1,2-Dimethyl-5-iodo-imidazole
- 58 1,2-Dimethyl-5-nitroimidazole



59 1,2-Dimethyl-5-nitroimidazole

SECTION 8 - Attempted SNR1 Reactions with Halogenoimidazoles

General Procedure for SNR1 Reactions.

60 5-(Diethylphosphono)-1,2-dimethylimidazole (Attempted)

61a 5-(Phenylthio)-1,2-dimethylimidazole (Attempted)

61b 5-(Phenylthio)-1,2-dimethylimidazole (Attempted)

61c 5-(Phenylthio)-1,2-dimethylimidazole (Attempted)

SECTION 9 - Preparation of Nitroso-Heterocycles

General Procedure for Preparations using n-Butyl Lithium

62 1,2-Dimethylimidazol-5-yl-diphenylmethanol and  
1-methylimidazol-2-yl-methyldiphenylmethanol

63a 1,2-Dimethyl-5-nitrosoimidazole (Attempted)

63b 1,2-Dimethyl-5-nitrosoimidazole (Attempted)

63c 1,2-Dimethyl-5-nitrosoimidazole (Attempted)

General procedure for Nitrosations using Sodium Alkoxide and  
Isoamyl Nitrite.

64a 4(5)-Nitroso-5(4)-phenylimidazole

64b 4(5)-Nitroso-5(4)-phenylimidazole

64c 4(5)-Nitroso-5(4)-phenylimidazole

65 5(4)-Methyl-4(5)-nitrosoimidazole (Attempted)

66 4(5)-Nitroso-2-phenylimidazole (Attempted)

67 4(5)-Nitroso-5(4)-phenylimidazole (Attempted)

68 2-Methyl-4(5)-nitrosoimidazole (Attempted)

69 2-Nitrosopyrrole (Attempted)

70 2,5-Dimethyl-3-nitrosopyrrole (Attempted)

71 3-Nitroso-pyrrole-2-carboxaldehyde (Attempted)

72 3-Nitrosopyrrole-2-carboxylic acid (attempted)

73 2-Methyl-3-nitrosoindole

74 2-Ethoxycarbonyl-3-nitrosoindole (Attempted)

75 3-Nitroso-2-phenylindole (Attempted)

General Procedure for Nitrosations using Nitrous Acid

76 1-Methyl-3-nitroso-2-phenylindole

77 1,2-Dimethyl-3-nitrosoindole (Attempted)

78 2-Ethoxycarbonyl-1-methyl-3-nitrosoindole (Attempted)

- 79 1-methyl-2-nitrosopyrrole (Attempted)
- 80 1,2-Dimethyl-5-nitrosoimidazole (Attempted)
- 81a 1-Methyl-5-nitroso-4-phenylimidazole
- 81b 1-Methyl-5-nitroso-4-phenylimidazole (Attempted)
- 81c 1-Methyl-5-nitroso-4-phenylimidazole (Attempted)
- 82 1,2-Dimethyl-3-nitrosoindole (Attempted)

SECTION 10 Reactions between Aromatic Amines and Nitroso  
Compounds

- 83 *p*-Aminotoluene/nitrosobenzene
- 84a 9-Benzyladenine/nitrosobenzene
- 84b 9-Benzyladenine/nitrosobenzene
- 85a *p*-Aminotoluene/4(5)-nitroso-5(4)-phenylimidazole
- 85b *p*-Aminotoluene/4(5)-nitroso-5(4)-phenylimidazole
- 86a 4-Aminopyridine/nitrosobenzene
- 86b 4-Aminopyridine/nitrosobenzene
- 87 2-Aminopyridine/nitrosobenzene
- 88 4(5)-Nitroso-5(4)-phenylimidazole/2-hydroxypyridine
- 89 9-Benzyladenine
- 90 9-Benzylguanine (Attempted)
- 91 1-Methylcytosine (Attempted)

SECTION 11 Reactions between Thiols and Nitroso-Heterocycles

General Procedure for Reactions between Thiols and Nitroso-Heterocycles.

- 92a 4(5)-Nitroso-5(4)-phenylimidazole/*p*-chlorothionophenol
- 92b 4(5)-Nitroso-5(4)-phenylimidazole/*p*-chlorothionophenol
- 92c 4(5)-Nitroso-5(4)-phenylimidazole/*p*-chlorothionophenol
- 93a 4(5)-Nitroso-5(4)-phenylimidazole/ethyl mercaptoacetate
- 93b 4(5)-Nitroso-5(4)-phenylimidazole/ethyl mercaptoacetate
- 93c 4(5)-Nitroso-5(4)-phenylimidazole/ethyl mercaptoacetate
- 93d 4(5)-Nitroso-5(4)-phenylimidazole/ethyl mercaptoacetate
- 93e 4(5)-Nitroso-5(4)-phenylimidazole/ethyl mercaptoacetate
- 93f 4(5)-Nitroso-5(4)-phenylimidazole/ethyl mercaptoacetate
- 94 4(5)-Nitroso-5(4)-phenylimidazole/*N*-acetylcysteine
- 95 1-Methyl 5-nitroso-4-phenylimidazole/*p*-chlorothiophenol

- 96a 1-methyl-5-nitroso-4-phenylimidazole/ethyl mercaptoacetate
- 96b 1-Methyl-5-nitroso-4-phenylimidazole/ethyl mercaptoacetate
- 96c 1-Methyl-5-nitroso-4-phenylimidazole/ethyl mercaptoacetate
- 96d 1-Methyl-5-nitroso-4-phenylimidazole/ethyl mercaptoacetate
- 97 1-Methyl-5-nitroso-4-phenylimidazole/N-acetylcysteine
- 98 2-Methyl-3-nitrosoindole/ethylmercaptoacetate
- 99 2-Methyl-3-nitrosoindole/N-acetylcysteine
- 100a 1,2-Dimethyl-5-nitroimidazole/ethyl mercaptoacetate
- 100b 1,2-Dimethyl-5-nitroimidazole/ethyl mercaptoacetate
- 100c 1,2-Dimethyl-5-nitroimidazole/ethyl mercaptoacetate
- 101 4(5)-Nitroso-5(4)-phenylimidazole/methanol
- 102 Disulphide of ethyl mercaptoacetate

SECTION 1      GENERAL PROCEDURES AND INSTRUMENTATION

- (a) I.R. spectra were determined as Nujol mulls for solids and as thin films for liquids on a Pye Unicam PU9516 IR spectrophotometer.
- (b) <sup>1</sup>H N.M.R. spectra were determined at 60 MHz on a Varian EM360A instrument, or at 400 MHz on a Bruker instrument by the Boots Company in Nottingham. Samples were analysed as solutions in CDCl<sub>3</sub>, or as otherwise indicated, using SiMe<sub>4</sub> as internal standard. <sup>13</sup>C N.M.R. spectra were determined on a Bruker WP-80 spectrometer. Analyses of reaction mixtures were carried out using a known amount of p-dinitrobenzene as an internal standard.
- (c) U.V. spectra were determined as solutions in ethanol, methanol, or water against the appropriate solvent as a reference on a Shimadzu UV-160 instrument.
- (d) Electrochemical reactions were carried out in a specially designed cell using a Thompson Electrochemical Ltd. Ministat precision potentiostat.
- (e) Melting points were determined on a Reichert hot stage microscope and are uncorrected.
- (f) Mass spectra were carried out on a Kratos MS 80 instrument.

General Procedure for electron spin resonance (e.s.r.) spectroscopic analyses

Degassed samples were irradiated in dilute solution (ca. 1% v/v) in CD<sub>3</sub>OD or MeTHF. Samples were frozen to small beads in liquid nitrogen and irradiated at 77K in a Vickrad <sup>60</sup>Co γ-ray source with doses up to 1 Mrad. E.s.r. spectra were

measured with a Varian E109 spectrometer. Samples were annealed to selected temperatures or until changes occurred in the e.s.r. spectra, and re-cooled to 77 K for study. For the CD<sub>3</sub>OD systems solute radicals were detectable at 77 K, but for the MeTHF systems it was necessary to anneal until the solvent radicals features were lost before well defined solute features were observed.

#### Solvent Drying Procedures

- (a) Ethanol and methanol were distilled from magnesium turnings and iodine and stored over 3 A molecular sieves.
- (b) Diethyl ether was distilled from calcium chloride and stored over sodium wire.
- (c) THF was distilled from lithium aluminium hydride immediately prior to its use.
- (d) Acetone was distilled from potassium permanganate and stored over 3 A molecular sieves.
- (e) Pyridine was stored over sodium hydroxide pellets.
- (f) DMF was distilled from calcium hydride under reduced pressure and stored over 3 A molecular sieves.
- (g) Toluene was distilled from calcium chloride under reduced pressure and stored over sodium wire.
- (h) DMSO was distilled under reduced pressure and stored over 3 A molecular sieves.
- (i) Liquid ammonia was distilled onto sodium metal and re-distilled immediately prior to its use.

## SECTION 2

## PREPARATION OF NITROIMIDAZOLES

### 1. Preparation of 4(5)-nitroimidazole

Fuming nitric acid (16 ml) was added dropwise to imidazole (8 g, 0.117 mol) over 30 min whilst cooling in an ice bath. Sulphuric acid (16 ml) was added to the mixture whilst cooling was maintained. The nitration mixture was heated to about 60°C until copious quantities of brown nitrogen oxides were produced, cooled briefly in an ice salt bath, and heated at 55°C for 2 h. The reaction mixture was poured onto ice (300 ml) and left for 18 h. The resulting yellow precipitate was filtered and dried (8.2 g, 62%); m.p. 292-294°C (lit.<sup>97</sup>, 292-294°C);  $\nu_{\max}$  3140 (free NH), 3200 to 2600 (H-bonded NH), 1552 (NO<sub>2</sub> asymmetric stretch), and 1338 (NO<sub>2</sub> symmetric stretch) cm<sup>-1</sup>.

### 2. Preparation of 5(4)-methyl-4(5)-nitroimidazole

Nitric acid (16 ml) was added dropwise to 4-methylimidazole (9.6 g, 0.117 mol) over 15 min whilst cooling in an ice bath. Sulphuric acid (16 ml) was then added whilst cooling was maintained. The reaction mixture was then heated at 55°C for 2 h. and poured onto ice (300 ml) and allowed to stand for 18 h. The resulting yellow precipitate was filtered and dried. Yield of 5(4)-methyl-4(5)-nitroimidazole (7.9 g, 53%); m.p. 250-251°C (lit.<sup>47</sup>, 251-252°C);  $\nu_{\max}$  3184 (free NH), 3400 to 2600 (H-bonded NH), and 1594 (NO<sub>2</sub>) cm<sup>-1</sup>;  $\delta_{\text{H}}$  (CDCl<sub>3</sub>/d<sub>6</sub>-DMSO) 2.61 (3 H, s, C-4(s)Me) and 7.53 (1 H, s, ring H).

### 3. Preparation of 1-methyl-4-nitroimidazole

Dimethyl sulphate (1.33 g, 11 mmol) was added to a solution of 4(5)-nitroimidazole (2.0 g, 17 mmol) in 2 M sodium hydroxide solution (10 ml) whilst cooling in an ice bath. A

further addition of hydroxide (10 ml) and dimethyl sulphate (1.33 g, 11 mmol) was made and the resulting mixture stirred for 5 min after which time heat was evolved and a solid formed. The mixture was stirred for a further 15 min whilst being cooled then filtered and the filtrate extracted with chloroform (3 × 100 ml). The extract was dried (MgSO<sub>4</sub>) and evaporated to dryness under vacuum to give a solid which was combined with the filtered material and recrystallised from water to give yellow needles of 1-methyl-4-nitroimidazole (0.73 g, 33%); m.p. 132-133°C (lit.<sup>42</sup>, 133-134°C);  $\nu_{\max}$  1526 (NO<sub>2</sub>) cm<sup>-1</sup>.

#### 4. Preparation of diazomethane

A solution of diazald (62) (43 g, 200 mmol) in ether (250 ml) was added to a solution of potassium hydroxide (10 g, 200 mmol), water (15 ml) and ethanol (50 ml). The resulting mixture was heated to 60°C and the diazomethane/ether vapour was condensed using an acetone/CO<sub>2</sub> cold finger trap. The ethereal diazomethane solution was sealed and refrigerated for later use.

#### 5. Preparation of 1-methyl-5-nitroimidazole

(a) An ethereal solution of diazomethane (1 g, 24 mmol) was added to 4(5)-nitroimidazole (1.5 g, 13 mmol) in ether (50 ml) and stirred for 6 h. The excess diazomethane was destroyed by treatment with acetic acid which was added dropwise. The solvent was removed under vacuum to give a buff solid which was recrystallised from ether to yield 1-methyl-5-nitroimidazole (1.4 g, 84%); m.p. 50-52°C (lit.<sup>42</sup>, 55°C);  $\nu_{\max}$  1538 (NO<sub>2</sub>) and 1328 (NO<sub>2</sub>) cm<sup>-1</sup>.

(b) 4(5)-nitroimidazole (1.5 g, 13 mmol) and methyl *p*-toluenesulphonate (2.9 g, 17 mmol) were heated together at 140°C for 4 h under nitrogen. The cooled reaction

melt was dissolved in saturated aqueous sodium hydrogen carbonate solution (100 ml) and extracted with chloroform (3 × 100 ml). The chloroform extracts were dried (MgSO<sub>4</sub>) and evaporated to dryness under vacuum to give an off-white solid which was recrystallised from ether to give 1-methyl-5-nitroimidazole (0.7 g, 45%); m.p. 55-58°C (lit.42, 55°C);  $\nu_{\max}$  1540 (NO<sub>2</sub>), and 1330 (NO<sub>2</sub>) cm<sup>-1</sup>

6. Preparation of 1,5-dimethyl-4-nitroimidazole

Dimethyl sulphate (1.33 g, 11 mmol) was added to a solution of 5(4)-methyl-4(5)nitroimidazole (2.3 g, 17 mmol) in a 2 M sodium hydroxide solution (10 ml) whilst cooling in ice. A further addition of 2 M hydroxide (10 ml) and dimethyl sulphate (1.33 g, 11 mmol) was made and the reaction mixture was stirred for 5 min, at which time a solid formed and heat was evolved. Stirring was maintained for a further 15 min and the solid filtered. The filtrate was extracted with chloroform (3 × 100 ml), dried (MgSO<sub>4</sub>) and evaporated to dryness under vacuum to give a solid which was combined with the filtered material and recrystallised from water to give yellow needles of 1,5-dimethyl-4-nitroimidazole (0.73 g, 33%); m.p. 132-133°C (lit.47, 133-134°C);  $\nu_{\max}$  1562 (NO<sub>2</sub>) cm<sup>-1</sup>.

7. Preparation of 1,4-dimethyl-5-nitroimidazole

(a) 5(4)-methyl-4(5)-nitroimidazole (1.5 g, 12 mmol) was heated with methyl *p*-toluenesulphonate (2.5 g, 14 mmol) for 4 h at 140°C under nitrogen to give a yellow solid. The solid was dissolved in saturated sodium hydrogen carbonate solution (100 ml) and extracted with dichloromethane (4 × 100 ml). The dichloromethane extracts were dried (MgSO<sub>4</sub>) and evaporated to dryness under vacuum to give a yellow solid which was recrystallised from ether to yield 1,4-dimethyl-5-



nitroimidazole (1.0 g, 64%); m.p. 59-61°C (lit.47, 60-61°C);  $\nu_{\max}$  1547 (NO<sub>2</sub>), and 1308 (NO<sub>2</sub>) cm<sup>-1</sup>;  $\delta_{\text{H}}$  (CDCl<sub>3</sub>/d<sub>6</sub>-DMSO) 2.55 (3 H, s, C-4 Me) 3.71 (3 H, s, NMe) 7.6 (1 H, s, 2-H).

(b) An ethereal solution of diazomethane (1 g, 24 mmol) was added to 5(4)-methyl-4(5)-nitroimidazole (1.5 g, 13 mmol) in ether (50 ml) and stirred for 6 h. The excess diazomethane was destroyed by treatment with acetic acid. The solvent was removed under vacuum to give a brown solid which was recrystallised from water to yield 1,4-dimethyl-5-nitroimidazole (1.0 g, 90%); m.p. 58-59°C (lit.47, 60-61°C);  $\nu_{\max}$  1546 (NO<sub>2</sub>) cm<sup>-1</sup>;  $\delta_{\text{H}}$  (CDCl<sub>3</sub>/d<sub>6</sub>-DMSO) 2.6 (3 H, s, C-4 Me) 3.70 (3 H, s, NMe) and 7.55 (1 H, s, C-2 H).

#### 8. Preparation of 1,2-dimethyl-5-nitroimidazole

An ethereal solution of diazomethane (3 g, 71 mmol) was added to 2-methyl-4(5)-nitroimidazole (4 g, 31 mmol) and methanol (3 ml) and allowed to stand for 18 h. The resulting orange solution was evaporated to dryness under vacuum to give an orange solid which as recrystallised from water to give colourless crystals of 1,2-dimethyl-5-nitroimidazole (1.5 g, 34%); m.p. 138-140°C (lit.4, 138-139°C);  $\nu_{\max}$  1522 (NO<sub>2</sub>), and 1325 (NO<sub>2</sub>) cm<sup>-1</sup>;  $\delta_{\text{H}}$  2.5 (3 H, s, C-2 Me) 3.9 (3 H, s, NMe) and 7.9 (1 H, s, 4-H).

#### 9. Attempted preparation of allyl p-toluenesulphonate

Toluene sulphonyl chloride (3.9 g, 20.5 mmol) was added to a solution of allyl alcohol (0.6 g, 10 mmol) and pyridine (10 ml) at 0°C. The reaction mixture was allowed to warm to room temperature and was stirred for 18 h then poured into ice/water. The resulting aqueous solution was extracted with ether (3 × 50 ml). The ethereal extracts were combined, washed with water (2 × 50 ml) then dried (MgSO<sub>4</sub>) and

evaporated to dryness under vacuum to give an oily product (0.7 g). T.l.c. and  $^1\text{H}$  n.m.r. spectroscopic analysis indicated the product to consist of unreacted starting materials. Repeated reactions gave similar results and at no time was any of the expected allyl *p*-toluenesulphonate observed.

#### 10 Preparation of allyl *p*-toluenesulphonate

25% Aqueous sodium hydroxide solution (35 ml, 220 mmol) was added dropwise to a solution of allyl alcohol (25.6g, 440 mmol) and *p*-toluenesulphonyl chloride (38.2 g, 200mmol), at 0-10°C. The reaction mixture was allowed to stand for 18 h and was poured into ice water (200 ml), dried ( $\text{MgSO}_4$ ) and evaporated to dryness under vacuum to give allyl *p*-toluenesulphonate as a colourless oil (30.4 g, 72%);  $\nu_{\text{max}}$  (neat liquid) 1596 (aromatic ring), 1364 and 1190 (S=O), and 838 to 816 (*p*-disubstitution)  $\text{cm}^{-1}$ ;  $\delta_{\text{H}}$  2.4 (3 H, s,  $\text{CH}_3$ ), 4.6 (2 H, d,  $\text{CH}_2$ ), 5.0 to 6.2 (3 H, m,  $-\text{CH}=\text{CH}_2$ ), and 7.6 (4 H, q, aromatic ring).

#### 11 Preparation of 1-allyl-2-methyl-5-nitroimidazole

2-Methyl-4(5)-nitroimidazole (5.0 g, 40 mmol) and allyl *p*-toluenesulphonate (10.6 g, 50 mmol) were heated at 130°C for 3 h. The cooled melt was dissolved in water (600 ml) which was made alkaline by the addition of aqueous ammonia solution and extracted with chloroform (4 × 200 ml). The chloroform extracts were dried ( $\text{MgSO}_4$ ) and evaporation to dryness under vacuum to yield a brown oil. Column chromatography using neutral alumina as absorbent with ethyl acetate - light petroleum (b.p. 60-80°C) (1:2) as eluent gave 1-allyl-2-methyl-5-nitroimidazole (1.2 g, 20%);  $\nu_{\text{max}}$  (neat liquid) 3128 and 3088 (aromatic and vinylic CH stretches), 1644 (C=C), 1528 and 1364 (N=O)  $\text{cm}^{-1}$ ;  $\delta_{\text{H}}$  2.5 (3 H, s, C-2 Me) 4.6 (2 H, d,  $\text{CH}_2$ ) 5.0 to 6.2 (3 H, m,  $\text{CH}=\text{CH}_2$ ) and 7.9 (1 H, s, 4-H).

12 Preparation of but-3-en-1-yl p-toluenesulphonate

25% Aqueous sodium hydroxide solution (5 ml, 33 mmol) was added dropwise to a mixture of 3-buten-1-ol (4.5 g, 31 mmol) and p-toluenesulphonyl chloride (6 g, 31 mmol) at 0°C. The reaction mixture was allowed to stand for 18 h and then poured onto ice (50 ml). The resulting aqueous solution was extracted with ether (3 × 50 ml). The ethereal extracts were combined, washed with water (50 ml), dried (MgSO<sub>4</sub>) and evaporated to dryness under vacuum to give a but-3-en-1-yl p-toluenesulphonate as a pale yellow oil (6.3 g, 88%);  $\nu_{\max}$  (neat liquid) 1640 (C=C). 1360 and 1190 (S=O), and 838 to 816 (p-disubstitution) cm<sup>-1</sup>;  $\delta_{\text{H}}$  2.3 (2 H, t, CH<sub>2</sub>), 2.48 (3 H, s, CH<sub>3</sub>), 4.0 (2H, t, CH<sub>2</sub>), 4.7 to 6.05 (3 H, m, CH=CH<sub>2</sub>), and 7.5 (4 H, q, aromatic ring).

13 Preparation of 1-(but-3-en-1-yl)-2-methyl-5-nitroimidazole

2-Methyl-4(5)-nitroimidazole (8.9 g, 70 mmol) and but-3-en-1-yl p-toluenesulphonate (17.6 g, 77 mmol) were heated under nitrogen at 130°C for 18 h. The resulting melt was cooled and dissolved in 2 M aqueous sodium hydroxide solution (100 ml) and extracted with chloroform (5×100 ml). The chloroform extracts were dried (MgSO<sub>4</sub>) then evaporated to dryness under vacuum to give a brown oil (6.5 g). Column chromatography on a neutral alumina column with chloroform/ethanol gradient elution gave an orange oil which was further purified by the formation of the hydrochloride salt and subsequent rebasification to give a pale yellow solid. The solid was recrystallised from methyl acetate/n-hexane to yield 1-(but-3-en-1-yl)-2-methyl-5-nitroimidazole (1.65 g, 13%); m.p. 52-53°C;  $\nu_{\max}$  3112 and 3076 (-C=CH stretches), 1604 (C=C), and 1522 (N=O) cm<sup>-1</sup>;  $\delta_{\text{H}}$  2.51 (3 H, s, C-2 Me) 2.53 (2 H, t, CH<sub>2</sub>) 4.41 (2 H, m, CH<sub>2</sub>) 4.81, 5.1 and 5.3 (2 H, 3xm, CH<sub>2</sub>=) (trans  $J_{\text{ab}}$  = 16 Hz, cis  $J_{\text{ac}}$  = 10 Hz, gem  $J_{\text{bc}}$  =

2 Hz) 5.85 (1 H, m, -CH=) 6.82 (2 H, d, ring H).

#### 14 Preparation of 1-methyl-2-thiomethylimidazole

A 10 M solution of aqueous sodium hydroxide (16 ml) was added to 1-methyl-2-mercaptoimidazole (10 g, 88 mmol) in methanol (100 ml) whilst a temperature of < 10 C was maintained. A solution of methyl iodide (13.2 g, 92 mmol) and methanol (20 ml) was added over 30 min to the imidazole solution at 15°C. After stirring for 18 h under an atmosphere of nitrogen, the solvent was removed under vacuum. The residue was dissolved in water (100 ml) and extracted with dichloromethane (5 × 100 ml). The Dichloromethane extracts were combined, dried (MgSO<sub>4</sub>) and evaporated to dryness under vacuum to give a pale yellow oil (12.5 g). The product was further purified by column chromatography on silica gel with chloroform/ethanol gradient elution to give 1-methyl-2-thiomethylimidazole as a pale yellow oil (10.2 g, 91%);  $\nu_{\max}$  (neat liquid) 3104, 3036, 2996, 2928, 1680, and 12508 cm<sup>-1</sup>;  $\delta_{\text{H}}$  2.52 (3 H, s, Me), 3.53 (3 H, s, NMe), and 6.8 (2 H, dxd, ring protons).

#### 15 Preparation of 1-methyl-5-nitro-2-methylthioimidazole

1-Methyl-2-thiomethylimidazole (10 g, 78 mmol) was added dropwise to nitric acid (d. 1.42, 50 ml) at 80°C with care. After 1 h the mixture was cooled to 10°C and poured onto ice (200 ml) to give a green/yellow solution which was added to acetic acid (30 ml). The resulting solution was basified (pH 10) using 10 M aqueous sodium hydroxide and was extracted with dichloromethane (4 × 100 ml). The organic extracts were dried (MgSO<sub>4</sub>) and evaporated to dryness under vacuum to give 1-methyl-5-nitro-2-thiomethylimidazole as a yellow solid (4.2 g, 31%); m.p. 88.5-89.5°C (lit.,<sup>44</sup> 90-91°C);  $\delta_{\text{H}}$  (3 H, s, SMe) 3.88 (3 H, s, NMe) and 7.8 (1 H, s, 4-H).

16 Preparation of 1-methyl-2-methylsulphonyl-5-nitroimidazole

An ethereal solution of monoperoxyphthalic acid (MPPA) (50 ml, 18 mmol) was added to a solution of 1-methyl-5-nitro-2-thiomethylimidazole (3 g, 17.5 mmol) in dichloromethane (100 ml) at 0°C. The resulting mixture was stirred for 18 h and then gently refluxed for 2 h. The precipitated phthalic acid was filtered, and washed with dichloromethane which was combined with the filtrate and cooled in ice. Potassium hydrogencarbonate was added to the solution until a small aliquot of the organic layer did not give colour with starch and potassium iodide solution. The dichloromethane solution was dried (MgSO<sub>4</sub>) and evaporated to dryness under vacuum to give a solid. The crude product was recrystallised from dichloromethane/ether to give 1-methyl-2-methylsulphonyl-5-nitroimidazole as pale yellow crystals (1.9 g, 53%); m.p. 98-99°C (lit.,<sup>44</sup> 99°C);  $\nu_{\max}$  1370 and 1190 (S=O) cm<sup>-1</sup>;  $\delta_{\text{H}}$  2.72 (3 H, s, SO<sub>2</sub>Me), 3.85 (3 H, s, NMe), and 7.75 (1 H, s, ring proton).

17 Preparation of methylthiocarbamoylpyrrolidine

A solution of pyrrolidine (7.1 g, 100 mmol) and methyl isothiocyanate (7.4 g, 100 mmol) in benzene (100 ml) was refluxed for 12 h. The resulting solution was cooled and the crystals which formed were filtered. Addition of light petroleum to the filtrate gave more solid. The solids were combined and recrystallised from benzene/hexane to give methylthiocarbamoylpyrrolidine as colourless needles (12.2 g, 84%); m.p. 119.5-120.5°C (lit.,<sup>44</sup> 122-123°C);  $\nu_{\max}$  3264 (NH), 1548 and 1528 cm<sup>-1</sup>;  $\delta_{\text{H}}$  1.95 (4 H, dxt, CH<sub>2</sub>), 3.0 (3 H, s, NMe), and 3.55 (4 H, t, NCH<sub>2</sub>).

18 Preparation of the S-methyl derivative of methylthiocarbamoylpyrrolidine

A solution of methylthiocarbamoylpyrrolidine (12 g, 83 mmol)

and methyl iodide (14.2 g, 100 mmol) in chloroform (100 ml) was refluxed for 4 h. The chloroform was removed under vacuum to give a pale yellow solid which was recrystallised from chloroform/light petroleum to yield the 5-methyl derivative of methylthiocarbamoylpyrrolidine as yellow crystals (21.7 g, 91%); m.p. 119-120°C (lit.,<sup>44</sup> 118-119°C);  $\nu_{\max}$  3204, 3144, and 1600  $\text{cm}^{-1}$ ,  $\delta_{\text{H}}$  2.19 (4 H, t,  $\text{CH}_2$ ), 2.81 (3 H, s, SMe), 3.35 (3 H, d, NMe), 4.0 (4 H, t,  $\text{NCH}_2$ ), and 8.7 (1 H, br, s, NH).

#### 19 Preparation of 1-methyl-2-(1-pyrrolidino)imidazole

A solution of the aminoacetaldehyde dimethyl acetal (9.8 g, 73 mmol) and the iodide salt of the S-methyl derivative of methylthiocarbamoylpyrrolidine (21 g, 73 mmol) in isopropanol (80 ml) was heated under reflux for 6 h. Hydrochloric acid (11 ml) was added to the cooled reaction mixture which was then heated under reflux for 2 h. The resulting solution was cooled and basified with 10% aqueous sodium hydrogen carbonate solution then extracted with dichloromethane (4  $\times$  100 ml). The dichloromethane extracts were combined, dried ( $\text{MgSO}_4$ ) and evaporated to dryness under vacuum to give 1-methyl-2-(1-pyrrolidino)imidazole as a brown oil (9.9 g, 90%);  $\nu_{\max}$  (neat liquid) 3140, 1636, and 1528  $\text{cm}^{-1}$ ;  $\delta_{\text{H}}$  1.9 (4 H, dxt,  $\text{CH}_2$ ), 3.36 (4 H, t,  $\text{NCH}_2$ ), 3.48 (3 H, s, NMe), and 6.63 (2 H, dxd, ring proton).

#### 20 Preparation of 1-methyl-5-nitro-2-(1-pyrrolidino)imidazole

Nitric acid (d. 1.42, 7.5 ml) was added to a solution of 1-methyl-2-pyrrolidinoimidazole (7.5 g, 49.7 mmol) in acetic acid (40 ml) at 0°C and was then stirred at 10 to 15°C for 3 h. The solution was basified using 880 ammonia (pH 10) and extracted into ether (4  $\times$  100 ml). The ether was dried ( $\text{MgSO}_4$ ) and evaporated to dryness under vacuum to give a gummy orange solid. Recrystallisation from n-hexane/ether

gave orange needles of 1-methyl-5-nitro-2-(1-pyrrolidino)  
imidazole (0.65 g, 7%); m.p. 74-75°C (lit., 44 75-76°C);  
 $\nu_{\max}$  1564 (N+O)  $\text{cm}^{-1}$ ;  $\delta_{\text{H}}$  2.08 (4 H, m, CH<sub>2</sub>) 3.66 (4 H, m,  
NCH<sub>2</sub>) 3.87 (3 H, s, NMe) 7.95 (1 H, s, 4-H).

General Method for Sodium Dithionite Reactions

The general procedure was followed except where otherwise indicated. Sodium dithionite was added over a 15 min period to a solution of the imidazole in potassium phosphate/hydrogen phosphate buffer (pH 8.5) which had been deoxygenated by bubbling oxygen-free nitrogen through for 3 h. The resulting solution was stirred under an atmosphere of nitrogen for variable lengths of time and extracted with dichloromethane (5 x 40 ml). The CH<sub>2</sub>Cl<sub>2</sub> extracts were combined, dried (MgSO<sub>4</sub>) and evaporated to dryness under vacuum to give the product.

21 Reduction of 1-(but-3-en-1-yl)-2-methyl-5-nitroimidazole

- (a) A solution of sodium dithionite (1.2 g, 6.9 mmol), and 1-(but-3-en-1-yl)-2-methyl-5-nitroimidazole (0.25 g, 1.38 mmol) in phosphate buffer (pH 8.5, 100 ml) were reacted as outlined in the general method for 3 h. Work up gave a dark greenish solid (65 mg). Analysis using <sup>1</sup>H n.m.r. spectroscopy indicated a number of other unidentified products. T.l.c. indicated a small amount of the starting imidazole and number of coloured products.
- (b) A solution of sodium dithionite (0.46 g, 2.8 mmol) and 1-(but-3-en-1-yl)-2-methyl-5-nitroimidazole (0.25 g, 1.38 mmol) in phosphate buffer (pH 9.5, 100 ml) were reacted as outlined in the general method for 3 h. work up gave a brown oily solid (0.13 g) which was shown by t.l.c. to consist of starting material imidazole and a number of coloured products. <sup>1</sup>H n.m.r. spectroscopy indicated a small amount of the starting material imidazole and a number of coloured



decomposition products.

- (c) A solution of sodium dithionite (0.957 g, 5.5 mmol), and 1-(but-3-en-1-yl)-2-methyl-5-nitroimidazole (0.2 g, 1.1 mmol) in phosphate buffer (pH 7.5, 100 ml) was reacted as indicated in the general method for 1 h. Work up yielded a green-brown solid (60 mg) which was shown by t.l.c. to consist of starting imidazole and a number of coloured products. <sup>1</sup>H n.m.r. spectroscopy indicated a small amount of unreacted starting imidazole and a number of unidentified decomposition products.

22 Reduction of 1,2-methyl-5-nitroimidazole in the presence of thymine

- (a) A solution of sodium dithionite (3.04 g, 17 mmol), 1,2-methyl-5-nitroimidazole (0.5 g, 1.0 mmol), and thymine (0.49g, 1.1 mmol) in phosphate buffer (pH 9.5, 100 mmol) was reacted as outlined in the general method for 30 min. Work up gave a yellow solid (0.12 g) which darkened on standing;  $\delta_{\text{H}}$  ( $d_6$ -DMSO) 1.6 (s), 1.8 (d), 2.65 (s), 2.75 (s), 2.94 (broad s), 3.75 (s), 3.85 (s), and 7.85 (s).; The n.m.r. spectrum indicated that the reaction products included starting imidazole and thymine in addition to other unidentified products. T.l.c. indicated a small amount of starting imidazole and a number of coloured products.
- (b) A solution of sodium dithionite (3.04 g, 5.5 mmol), and 1,2-dimethyl-5-nitroimidazole (0.5 g, 1 mmol) in phosphate buffer (pH 8, 100 ml), was reacted as outlined in the general method for 30 min with the addition of thymine (0.49 g, 1.1 mmol). Work up gave a yellow solid (0.11 g). T.l.c. on neutral alumina with chloroform as eluent indicated some starting imidazole and in excess of 20 coloured bands which proved

impossible to separate.

- (c) A solution of 1,2-dimethylimidazole (0.5 g, 1 mmol) in phosphate buffer (pH 8, 500ml) and a solution of sodium dithionite (1.2 g, 2.2 mmol) in phosphate buffer (pH 8, 500 ml) were added to thymine (1.5 g, 3.3 mmol) in phosphate buffer (pH 8, 1 l) over 24 h. The water was removed under vacuum to yield an off-white solid which was dried for 2 days in a desiccator. The solid was thoroughly washed with chloroform and the washings reduced under vacuum to give a white solid (23 mg) which was shown by t.l.c. and n.m.r spectroscopy to be a mixture of thymine and the 1,2-dimethyl-5-nitroimidazole. Further washing with methanol gave a solid (1.195 g) which was found to be a mixture of inorganic salts and thymine.

#### SECTION 4 ELECTROCHEMICAL REDUCTION OF NITROIMIDAZOLES

##### General Procedure for electrochemical reductions

All of the electrochemical reduction studies were carried out in the same cell. The reductions were performed in 0.1 mol dm<sup>-3</sup> aqueous sodium chloride solution which was continuously purged with oxygen-free nitrogen, using a platinum gauze anode and a lead cathode. All potentials reported are with reference to saturated sodium calomel reference electrode.

The cell was charged with aqueous sodium chloride solution and purged with oxygen-free nitrogen for 30 min. At this point the remaining reactants were introduced and the cell purged for a further 30 min. A potential difference was then applied across the cell giving an immediate rise in current. The potential was applied until the current ceased to decrease after which time the reaction mixture was extracted with chloroform (3 × 100 ml) which was dried (MgSO<sub>4</sub>) and reduced under vacuum to give the crude product. Progress of the reactions were monitored by u.v. spectroscopy of aliquots run against 0.1 mol dm<sup>-3</sup> aqueous sodium chloride solution.

##### 23 Reduction of 1,2-dimethyl-5-nitroimidazole

1,2-dimethyl-5-nitroimidazole (10 mg, 0.07 mmol) was introduced into the electrochemical cell as described in the general procedure. The addition resulted in an instantaneous rise in current indicating a reaction was taking place. The potential difference applied to the cell was varied between -600 mV and -1800 mV to determine the optimum potential for the reduction of nitroimidazoles. A potential range of between -700 mV and -1000 mV was deemed suitable and subsequent reactions were carried out with a potential of -800 mV.

24 Reduction of 1,2-dimethyl-5-nitroimidazole in the presence of thymine

Thymine (200 mg, 1.6 mmol) was added to the cell and a potential of -800 mV was applied. No increase in current was observed indicating that the thymine did not reduce under the intended reaction conditions. 1,2-Dimethyl-5-nitroimidazole (50 mg, 0.7 mmol) was introduced as outlined in the general procedure giving a rise in current from 2.3 mA to > 130 mA. After 2 h, the current had dropped to 40 mA and a further addition of 1,2-dimethyl-5-nitroimidazole (50 mg, 0.7 mmol) was made causing the current to rise to 320 mA. After 18 h, the current ceased to decrease and had stabilised at 50 mA and the reaction was terminated. Work up gave a greenish solid (180 mg) which was shown by t.l.c. and u.v. spectroscopy to consist of unreacted thymine and many unidentified coloured products resulting from the reduction of the nitroimidazole.

25 Reduction of 1,2-dimethyl-5-nitroimidazole in the presence of thymidine

Thymidine (170 mg, 0.7 mmol) was introduced to the cell and a potential of -800 mV was applied. No increase in current was observed indicating that thymidine did not reduce under the intended reaction conditions. 1,2-Dimethyl-5-nitroimidazole (50 mg, 0.7 mmol) was added to the cell giving an immediate increase in current from 3 mA to >140 mA. After 18 h, the reaction solution had become deep yellow in colour and the current had stabilised at around 40 mA. Work up gave an orange/brown solid (13 mg) which was shown by t.l.c. and u.v. and <sup>1</sup>H n.m.r. spectroscopy to consist of many coloured nitroimidazole decomposition products. The aqueous reaction mixture was evaporated to dryness under vacuum to give an off-white solid which was shown by t.l.c. and u.v. spectroscopy to consist of unreacted thymidine and inorganic salts.

26 Reduction of 1,2-dimethyl-5-nitroimidazole in the presence of cytosine

Cytosine (90 mg, 0.7 mmol) was introduced to the cell and a potential of -800 mV was applied. No increase in current was observed indicating that cytosine did not reduce under the intended reaction conditions. 1,2-Dimethyl-5-nitroimidazole (50 mg, 0.7 mmol) was added to the cell giving an increase in current from 3 mA to > 40 mA. After 96 h the current had stabilised at 30 mA and the reaction was terminated. Work up gave a brown solid (75 mg) which was shown by t.l.c. and u.v. spectroscopy to consist of unreacted cytosine and coloured decomposition products derived from 1,2-dimethyl-5-nitroimidazole.

27 Reduction of 1,2-dimethyl-5-nitroimidazole in the presence of guanosine

Guanosine (200 mg, 0.7 mmol) was introduced to the cell and a potential of -800 mV was applied. No increase in current was observed indicating that guanosine did not reduce under the intended reaction conditions. 1,2-Dimethyl-5-nitroimidazole (50 mg, 0.7 mmol) was added to the cell giving an increase in current from 3 mA to >130 mA. After 96 h the current had stabilised at 40 mA and the reaction was terminated. Work up gave a brown solid (25 mg) which was shown by t.l.c. and u.v. spectroscopy to consist of unreacted guanosine and coloured decomposition products derived from 1,2-dimethyl-5-nitroimidazole. The aqueous reaction mixture was evaporated to dryness under vacuum to give an off-white solid which t.l.c. and u.v. spectroscopic analysis showed to consist of unreacted guanosine and inorganic salts.

28 Reduction of 1,2-dimethyl-5-nitroimidazole in the presence of adenine

Adenine (100 mg, 0.7 mmol) was introduced to the cell and a

potential of -800 mV was applied. No increase in current was observed indicating that adenine did not reduce under the intended reaction conditions. 1,2-dimethyl-5-nitroimidazole (50 mg, 0.7 mmol) was added to the cell causing an increase in current from 3 mA and >140 mA. After 72 h the current had stabilised at 30 mA and the reaction was terminated. Work up gave a brown/green solid (30 mg) which was shown by t.l.c. and u.v. spectroscopy to consist of unreacted adenine and coloured nitroimidazole. The aqueous reaction mixture was evaporated to dryness under vacuum to give an off-white solid which was shown by t.l.c. and u.v. spectroscopy to consist of unreacted adenine and inorganic salts.

29 Reduction of 1,2-dimethyl-5-nitroimidazole in the presence of cysteine

Cysteine (160 mg, 2.1 mmol) was introduced to the cell and a potential was applied. No increase in current was observed indicating that cysteine did not reduce under the intended reaction conditions. 1,2-Dimethyl-5-nitroimidazole (150 mg, 2.1 mmol) was added causing the current to rise from 2 mA to >130 mA. After 20 h the current had stabilised at 45 mA and the reaction was terminated. Work up gave a green/brown solid (112 mg) which was shown by t.l.c. and u.v. spectroscopy to consist of 1,2-dimethyl-5-nitroimidazole derived coloured decomposition products and unreacted cysteine.

30 Reduction of 1-allyl-2-methyl-5-nitroimidazole

1-Allyl-2-methyl-5-nitroimidazole (160 mg, 1.0 mmol) was introduced to the cell as outlined in the general procedure. A potential of -800 mV was applied causing the current to rise from 3 mA to 350 mA. After 24 h the current had stabilised at 35 mA and the reaction was terminated. Work up gave a green/brown solid (85 mg) which was shown by t.l.c. u.v. and <sup>1</sup>H n.m.r. spectroscopy to consist of

coloured decomposition products. Attempts to isolate major products by column chromatography or preparative t.l.c. resulted in further decomposition.

31 Reduction of 1-(but-3-en-1-yl)-2-methyl-5-nitroimidazole

1-(But-3-en-1-yl)-2-methyl-5-nitroimidazole (1280 mg, 1.0 mmol) was introduced to the cell and a potential of -800 mV was applied causing the current to rise from 2.5 mA to 320 mA. After 36 h the current had stabilised at 30 mA and the reaction was terminated. Work up gave a green/brown solid (115 mg) which was shown by t.l.c., u.v., and <sup>1</sup>H n.m.r. spectroscopy to consist of coloured decomposition products. Attempts to isolate the major products by column chromatography or preparative t.l.c. resulted in further decomposition.

32 Preparation of 2,4,4,6-tetrabromocyclohexa-2,5-dienone

A solution of bromine (3.2 g, 20 mmol) in glacial acetic acid (20 ml) was added to a mixture of 2,4,6-tribromophenol (6.62 g, 20 mmol), sodium acetate (2.7 g, 20 mmol) and glacial acetic acid (40 ml). The reaction mixture was poured onto ice/water (100 ml) and gave a yellow precipitate which was filtered, dried and recrystallised from chloroform to give yellow needles of 2,4,4,6-tetrabromocyclohexa-2,5-dienone (3.38 g, 41%), m.p. 123-129°C (d) (lit.,<sup>66</sup> 125-130°C (d));  $\nu_{\max}$  3070 (CH=CH cis) and 1680 (C=O)  $\text{cm}^{-1}$ ;  $\delta_{\text{H}}$  7.61 (2 H, s).

33 Preparation of 4-bromoimidazole

2,4,4,6-Tetrabromocyclohexa-2,5-dienone (3 g, 7 mmol) was added to a solution of imidazole (0.5 g, 7 mmol) in ethanol (30 ml). The resulting solution was chromatographed on a silica gel column with acetone-light petroleum (b.p. 60-80°C) (2:5) as eluent. T.l.c. analysis showed the presence of four compounds which eluted in the order 2,4,5-tribromoimidazole, 4,5-dibromoimidazole, 4-bromoimidazole, and imidazole. The yield of 4-bromoimidazole was (65 mg, 6%). This method was abandoned in favour of the reduction approach.

34 Preparation of 2,4,5-tribromoimidazole

A solution of bromine (36 g, 0.225 mol) in chloroform (100 ml) was added to a solution of imidazole (10 g, 0.15 mol) in chloroform (250 ml). The hydrobromide salt which formed was filtered and treated with an aqueous solution of potassium carbonate to give the free base. The precipitate was filtered, dried, and recrystallised from aqueous ethanol to give colourless crystals of 2,4,5-tribromoimidazole (7.2 g, 20%), m.p. 220-221°C (lit.,<sup>64</sup> 221°C);  $\nu_{\max}$  3250 to 2000 (br



NH H-bonded) and 1538 (C=C)  $\text{cm}^{-1}$ . The  $^1\text{H}$  n.m.r. spectrum showed no observable peaks.

### 35 Preparation of 4-bromoimidazole

2,4,5-Tribromoimidazole (2 g, 8 mmol) and 20% aqueous sulphite solution (40 ml, 33 mmol) were heated together under reflux for 6 h. The solution was allowed to cool and was extracted with chloroform (2  $\times$  100 ml). The extracts were dried ( $\text{MgSO}_4$ ) and evaporated to dryness under vacuum to give 4-bromoimidazole (0.951 g, 41%). m.p. 131-132°C (from aqueous ethanol) (lit.,<sup>64</sup> 130-131°C);  $\nu_{\text{max}}$  3250 to 2000 (br NH H-bonded) and 1538 (C=C)  $\text{cm}^{-1}$ ;  $\delta_{\text{H}}$  6.8 (1 H, s, 5-H) and 7.1 (1 H, s, 2-H).

### 36 Preparation of 4,5-dibromo-2-methylimidazole

A solution of bromine (40g, 0.25 mol) in chloroform (100 ml) was added to a solution of 2-methylimidazole (20 g, 0.25 mol) in chloroform (250 ml). The precipitate which formed was treated with aqueous potassium carbonate solution to give the free base. The precipitate was filtered, dried and recrystallised from aqueous ethanol to give colourless crystals of 4,5-dibromo-2-methylimidazole (16 g, 28%), m.p. 223-224°C (lit.,<sup>62</sup> 239-240°C);  $\nu_{\text{max}}$  3200 to 2200 (br NH H-bonded) 3050 (NH free) and 1610 (C=C)  $\text{cm}^{-1}$ ;  $\delta_{\text{H}}$  2.33 (3 H, s, C-2 Me);  $\delta_{\text{C}}$  14.0 (q, C-2 Me) 105.9 and 106.2 (br s, C-4 and C-5) 145.8 (s, C-2); m/z 240 ( $\text{M}^+$ , 50%), 242 (26, 238 (26), 161 (35), and 159 (36).

### 37 Preparation of 4-bromo-2-methylimidazole

4,5-Dibromo-2-methylimidazole (15 g, 60 mmol) and a 20% aqueous solution of sodium sulphite (400 ml, 0.31 mol) were heated under reflux for 6 h. The resulting solution was allowed to cool and the crystalline product separated by filtration. The filtrate was extracted with diethyl ether (3  $\times$  200 ml). The etheral extracts were then dried ( $\text{MgSO}_4$ )

and evaporated to dryness under vacuum to yield a further crop of crystals. The combined crops of crystals were recrystallised from water to give 4-bromo-2-methylimidazole (8.6 g, 86%) m.p. 161-162°C (lit.,<sup>62</sup> 162-163°C);  $\nu_{\text{max}}$  3300 to 2000 (br NH H-bonded) 3140 (NH free) and 1527 (C=C)  $\text{cm}^{-1}$ ;  $\delta_{\text{H}}$  (90 MHz) 2.32 (3 H, s, C-2 Me) 6.84 (1 H, s, 5-H);  $\delta_{\text{C}}$  13.5 (q, C-2 Me) 112.1 (s, C-4) 114.9 (d, C-5) 144.5 (s, C-2); m/z 160 ( $\text{M}^+$ , 100%), 162 (95), 159 (13), 81 (37), and 54 (34).

### 38 Preparation of 4(5)-bromo-1,2-dimethylimidazole

Dimethyl sulphate (0.5 g, 40 mmol) was added to a solution of 4-bromo-2-methylimidazole (0.5 g, 31 mmol) and sodium hydroxide (0.21 g, 5 mmol) in ethanol (20 ml). Excess aqueous ammonia solution was added and the reaction mixture was allowed to stand at room temperature for 2 h and then refluxed for 30 min. The solvent was removed under vacuum to give a solid which was crystallised with methanol. The methanol was removed under vacuum to give an off-white solid (0.49 g). The solid was dissolved in water (100 ml) and extracted with diethyl ether (2 x 100 ml), which was dried ( $\text{MgSO}_4$ ) and evaporated to dryness under vacuum to yield a solid (0.2 g, 38 %) which was found to be a mixture of 4- and 5-bromo-1,2-dimethylimidazole;  $\delta_{\text{H}}$  2.34 (3 H, s, C-2 Me) 2.40 (3 H, s, C-2 Me) 3.53 (3 H, s, N-Me) 3.56 (3 H, s, C-2 Me) 6.75 (1 H, s, C-H) 6.91 (1 H, s, C-H). Attempts to separate the isomers by fractional crystallisation were unsuccessful.

### 39 Preparation of 5-bromo-1,2-dimethylimidazole

A 15% solution of n-butyl lithium in hexane (0.7 g, 11 mmol) was added to a solution of 1,2-dimethylimidazole (1 g, 10.4 mmol) in dry diethyl ether (25 ml) at -10°C under dry nitrogen over 10 min. The temperature was maintained at -10°C for 1 h and then reduced to -78°C. N-Bromosuccinamide

(1.85 g, 10.4 mmol) was added over 30 min. The reaction mixture was allowed to warm to ambient temperature and water (25 ml) was added followed by saturated sodium hydrogen carbonate solution (5 ml). The reaction mixture was extracted with diethyl ether (2×100 ml). The etheral extracts were washed with water (100 ml), dried (MgSO<sub>4</sub>), and evaporated to dryness under vacuum to give a yellow oil which crystallised on standing. The crystalline product was dissolved in 2 M hydrochloric acid (60 ml) and extracted with diethyl ether (2×50 ml). The aqueous phase was basified with sodium hydrogen carbonate and extracted with dichloromethane (2×100 ml). The organic extracts were dried (MgSO<sub>4</sub>) and evaporated to dryness under vacuum to give yellow crystals of 5-bromo-1,2-dimethylimidazole (0.17 g, 10%), m.p. 88-91°C (lit.,<sup>70</sup> 88-90°C);  $\delta_{\text{H}}$  2.26 (3 H, s, C-2 Me) 3.48 (3 H, s, N-Me) and 6.68 (1 H, s, 4-H).

#### 40 Preparation of 5-bromo-1,2-dimethylimidazole

4-Bromo-2-methylimidazole (10 g, 62 mmol) and methyl *p*-toluenesulphonate (12 g, 64 mmol) were heated together under nitrogen at about 140°C for 15 h. The reaction mixture was cooled and thoroughly triturated with sodium hydrogen carbonate solution (150 ml). The resulting solution was made strongly alkaline with 2M sodium hydroxide solution then extracted with dichloromethane (5 × 100 ml). The dichloromethane extracts were dried (MgSO<sub>4</sub>) and reduced under vacuum to give an off-white solid (6.662 g). The crude product was purified by chromatography on a dry column of neutral alumina with light petroleum (b.p. 40-60 °C)/chloroform gradient elution. Yield of the chromatographed 5-bromo-1,2-dimethylimidazole (5.195 g, 48%) m.p. 91-92°C (from ethyl acetate) (lit.,<sup>70</sup> 88-90°C);  $\nu_{\text{max}}$  1660 (aromatic ring) 1528 (C=C) and 756 (ring CH out of plane) cm<sup>-1</sup>;  $\delta_{\text{H}}$  2.30 (3 H, s, C-2 Me), 3.49 (3 H, s, NMe) and 6.7 (1 H, s, 4-H);  $\delta_{\text{C}}$  (CDCl<sub>3</sub>/d<sub>6</sub> -DMSO) 13.5 (q, CH<sub>3</sub>), 30.9 (q, NMe), 101.6 (s, C-5

Br), 126.5 (d, C-4H) and 145.5 (s, C-2).

41 Preparation of 4,5-dibromo-1,2-dimethylimidazole

Dimethylsulphate (1.9 g, 16 mmol) was added to a solution of 4,5-dibromo-2-methylimidazole (3.8 g, 16 mmol) and sodium hydroxide (2.1 g, 52 mmol) in ethanol (200 ml) and was stirred for 18 h. The ethanol was removed under vacuum to give a colourless solid which was dissolved in water (100 ml). The dichloromethane extracts were combined, dried (MgSO<sub>4</sub>) and evaporated to dryness under vacuum to give a colourless solid which was recrystallised from water to give 4,5-dibromo-1,2-dimethylimidazole (2.8 g, 69%); m.p. 78-79°C (lit.,<sup>71</sup> 88-90°C);  $\delta_{\text{H}}$  2.48 (3 H, s, C2-Me), 3.53 (3 H, s, NMe);  $\delta_{\text{C}}$  13.8 (q, C-2Me), 32.8 (q, N-Me), 102.8 (s, C5), 113.8 (s, C4), and 146.0 (s, C2).

42 Preparation of 1-allyl-5-bromo-2-methylimidazole

(a) Allyl p-toluenesulphonate (1.32 g, 6.2 mmol) and 4-bromo-2-methylimidazole (1.0 g, 6.2 mmol) were heated under reflux in toluene (30 ml) for 24 h. The reaction mixture was extracted with water (100 ml) which was then extracted with chloroform (3 × 100 ml). The chloroform extracts were dried (MgSO<sub>4</sub>) and evaporated to dryness under vacuum to give a brown oil (0.423 g, 34%);  $\delta_{\text{H}}$  2.3 (3 H, s, C(2) Me), 4.6 (2 H, d, CH<sub>2</sub>), 5.2 to 6.2 (3 H, m, CH=CH<sub>2</sub>) and 6.84 (1 H, s, CH). Chromatography on neutral alumina with chloroform as eluent gave a number of fractions. Fractions 3 to 6 yielded (6.8 mg);  $\delta_{\text{H}}$  2.3 (3 H, s, C-2 Me), 4.3 (2 H, d, CH<sub>2</sub>), 5.1 to 6.2 (3 H, m, CH=CH<sub>2</sub>) and 6.75 (1 H, s, CH);  $\delta_{\text{C}}$  13.9 (q, C-2 Me), 46.7 (t, NCH<sub>2</sub>), 102.1 (s, C-5), 117.2 (t, =CH<sub>2</sub>) 127.2 (d, C-4), 131.7 (d, =CH-) and 145.8 (s, C-2); Fractions 7 to 14 yielded (0.13 g);  $\delta_{\text{H}}$  2.3 (3 H, s, Me) and 6.9 (1 H, s, ring CH).

(b) 4,(5)-Bromo-2-methylimidazole (5 g, 31 mmol) and allyl *p*-toluenesulphonate (7 g, 38 mmol) were heated together under nitrogen at 140°C for 1.5 h. The cooled reaction mixture was dissolved in saturated sodium bicarbonate solution (100 ml) and extracted with dichloromethane (3 × 100 ml). The dichloromethane extracts were dried (MgSO<sub>4</sub>) and reduced under vacuum to give a brown oil (5.423 g, 86%) which was taken into ether (50 ml) and washed with 2 M aqueous sodium hydroxide solution (2 × 50 ml) and with water (100 ml). The ether was dried (MgSO<sub>4</sub>) and evaporated to dryness under vacuum to give an orange oil (1.7 g). The oil was chromatographed on neutral alumina using light petroleum (b.p. 60-80°C)/chloroform gradient elution giving 1-allyl-5-bromo-2-methylimidazole as a pale yellow oil (1.12 g, 18%);  $\nu_{\max}$  (neat liquid) 3120 and 3084 (aromatic C-H) 2984 and 2928 (aliphatic C-H) 1642 (allylic CH=CH<sub>2</sub>) and 1522 (ring C=C) cm<sup>-1</sup>;  $\delta_{\text{H}}$  2.31 (3 H, s, C-2 Me) 4.5 (2 H, d, NCH<sub>2</sub>) and 6.75 (1 H, s, 4-H).

43 Preparation of 5-bromo-1-(but-3-en-1-yl)-2-methylimidazole

4-Bromo-2-methylimidazole (3.1 g, 19.5 mmol) and but-3-en-1-yl *p*-toluenesulphonate (4.5 g, 19.5 mmol) were heated together under nitrogen at 140°C for 4 h. The reaction mixture was cooled and dissolved in saturated sodium hydrogen carbonate solution (100 ml) which was then extracted with dichloromethane (5 × 100 ml). The organic extracts were dried (MgSO<sub>4</sub>) and evaporated to dryness under vacuum to give a yellow oil which crystallised on cooling. The product was purified by chromatography on a short column of neutral alumina with light petroleum (b.p. 40-60°C)/chloroform gradient elution to yield the purified 5-bromo-1-(but-3-en-1-yl)-2-methylimidazole (1.531 g, 36%);  $\nu_{\max}$  (neat liquid) 3076 (aromatic C-H) 2956 (aliphatic C-H) 1638 (allylic C=C) and 1520 (ring C=C) cm<sup>-1</sup>;  $\delta_{\text{H}}$  2.38 (3 H, s, C-2

Me), 2.45 (2 H, t, CH<sub>2</sub>) 3.86 (2 H, t, CH<sub>2</sub>) 4.6 to 6.1 (3 H, m, CH=CH<sub>2</sub>) and 6.7 (1 H, s, 4-H).

45 Preparation of 4,5-di-iodo-2-methylimidazole

2-Methylimidazole (3.1 g, 40 mmol) was dissolved in 2 M aqueous sodium hydroxide (200 ml) and shaken with a solution of iodine (9.3 g, 36 mmol) in chloroform (800 ml) until the colour was discharged. The pH of the aqueous phase was adjusted to 5 by treatment with 2 M aqueous hydrochloric acid (200 ml) giving a precipitate which was filtered, dried and recrystallised from aqueous acetone to yield off-white crystals of 4,5-di-iodo-2-methylimidazole (3.6 g, 43%); m.p. 201-202°C (lit.,<sup>60</sup> 204-206°C);  $\nu_{\max}$  3250 to 2200 (NH stretch H-bonded) 3104 (NH stretch free) and 1540 (C=C) cm<sup>-1</sup>;  $\delta_{\text{H}}$  (CDCl<sub>3</sub>/d<sub>6</sub>-DMSO) 2.38 (3 H, s, C-2 Me); m/z 334 (M<sup>+</sup>, 82%), 254 (14), 208 (29), 207 (51), 166 (31), and 127 (25).

46 Preparation of 4,5-di-iodo-1,2-dimethylimidazole

Dimethylsulphate (1.9 g, 16 mmol) was added to a solution of 4,5-di-iodo-2-methylimidazole (5 g, 16 mmol) and sodium hydroxide (2.1 g, 52 mmol) in ethanol (200 ml) and stirred for 18 h. The ethanol was removed under vacuum to give a colourless solid which was dissolved in water (100 ml) and extracted with dichloromethane (4 × 100 ml). The dichloromethane extracts were dried (MgSO<sub>4</sub>) and evaporated to dryness under vacuum to give a colourless solid which was recrystallised from water to give 4,5-di-iodo-1,2-dimethylimidazole (1.485 g, 28%); m.p. 181-181°C (lit.,<sup>61</sup> 182-183°C);  $\nu_{\max}$  1525 (C=C);  $\delta_{\text{H}}$  (CDCl<sub>3</sub>/d<sub>6</sub>-DMSO) 2.4 (3, H, s, C-2 Me) and 3.5 (3 H, s, NMe);  $\delta_{\text{C}}$  (CDCl<sub>3</sub>/d<sub>6</sub>-DMSO) 14.0 (q, C-2 Me), 35.5 (q, NMe), 83.4 (s, C-5), 93.1 (s, C-4) and 149.1 (s, C-2).

47 Preparation of 4-iodo-2-methylimidazole

4,5-Di-iodo-2-methylimidazole (10 g, 10 mmol) was heated under reflux with 20% aqueous sodium sulphite solution (200

ml, 0.15 mmol) for 6 h. After this time some unreacted material remained and was filtered off. The filtrate was extracted with chloroform (3 × 100 ml). The chloroform was dried (MgSO<sub>4</sub>) and evaporated to dryness under vacuum to give 4-iodo-2-methylimidazole as a colourless solid (2.3 g, 37%); m.p. 140-142°C (lit.,<sup>61</sup> 141-142°C);  $\nu_{\max}$  3300 to 2100 (NH stretch H-bonded) and 1566 (C=C) cm<sup>-1</sup>;  $\delta_{\text{H}}$  2.36 (3 H, s, C-2 Me) and 6.90 (1 H, s, ring H); m/z 208 (m<sup>+</sup>, 100%), 127 (11), 81 (20), and 54 (10).

#### 48 Preparation of 1,2-dimethyl-5-iodo-imidazole

4-Iodo-2-methylimidazole (5 g, 24 mmol) and methyl p-toluenesulphonate (4.8 g, 26 mmol) were heated together under nitrogen at 140°C for 1.5 h. The cooled reaction mixture was dissolved in saturated sodium hydrogen carbonate solution (100 ml). The dichloromethane was dried (MgSO<sub>4</sub>) and then reduced under vacuum to yield a buff solid (3.55g). Chromatography on a short column of neutral alumina with light petroleum (b.p. 40-60°C)/chloroform gradient elution gave the purified imidazole (2.46 g, 45%); m.p. 181-182°C (lit.,<sup>70</sup> 182-183°C);  $\nu_{\max}$  1644 (ring) and 15125 (C=C) cm<sup>-1</sup>;  $\delta_{\text{H}}$  (CDCl<sub>3</sub>/d<sub>6</sub>-DMSO) 2.45 (3 H, s, C-2 Me), 3.57 (3 H, s, NMe) and 6.8 (1 H, s, 4-H).

#### 49 Attempted preparation of 1-allyl-5-iodo-2-methyl imidazole

4-Iodo-2-methylimidazole (1 g, 4.8mmol) and allyl p-toluenesulphonate (0.99 g, 5.3 mmol) were heated together under nitrogen at 140°C for 4 h. The reaction mixture was dissolved in saturated sodium hydrogen carbonate solution (100 ml) which was extracted with dichloromethane (3 × 100 ml). The organic extract was dried (MgSO<sub>4</sub>) and reduced under vacuum to give a viscous brown oil. Analysis of the oil by t.l.c and <sup>1</sup>H n.m.r. spectroscopy indicated that it consisted of decomposition products.

SECTION 6                    REDUCTION REACTIONS OF HALOGENOIMIDAZOLES  
USING TRI-BUTYLTIN HYDRIDE AS REDUCTANT

General method for tributyltin hydride reactions

The general procedure was followed except as outlined in each method detailed below.

- (a) Reductions and cyclisations were performed in toluene which had been distilled from calcium chloride under reduced pressure or in benzene dried and distilled from sodium. Studies were carried out under nitrogen by adding the required amount of AIBN radical initiator and tributyltin hydride to a solution of the compound in the appropriate solvent and heating under reflux whilst irradiating the reaction mixture with a 150 W tungsten white light lamps at a distance of 5 cm. Work up involved extraction of the reaction solution with 2 M HCl which was then basified with 2 M NaOH and extracted with dichloromethane. The organic extracts were dried over MgSO<sub>4</sub> and evaporated to dryness under vacuum to give the product.
- (b) Inhibition studies with oxygen were carried out by replacing nitrogen gas with oxygen gas.
- (c) Inhibition studies using a radical scavenger were carried out by the addition of 0.5 equivalents of di-*t*-butyl nitroxide to the initial reaction mixture.

50    Reduction of 5-bromo-1,2-dimethylimidazole

- (a) 5-Bromo-1,2-dimethylimidazole (0.5 g, 2.9 mmol) in benzene (40 ml) was treated with AIBN (.053 g, 0.32 mmol) and tributyltin hydride (0.92 g, 3.2 mmol) as indicated in the general procedure for 120 h. Work up gave a yellow oil (0.23 g, 100%);  $\delta_H$  2.14 (s, C-2 Me), 2.2 (s, C-2 Me), 3.37 (s, NMe), 3.40 (s, NMe), 3.43 (s,



NMe), 3.49 (d, NMe), 6.34 (s) 6.57 (s) and 6.67 (s).

- (b) 5-Bromo-1,2-dimethylimidazole (0.35 g, 2 mmol) in toluene (25 ml) was treated with AIBN (0.164 g, 1.0 mmol) and tributyltin hydride (2.91 g, 10 mmol) as indicated in the general procedure for 48 h. Work up gave a yellow oil (0.174 g). A yield (50%) was calculated using n.m.r. spectroscopy with *p*-dinitrobenzene as internal standard;  $\delta_{\text{H}}$  2.35 (3 H, s, C-2 Me reduced material) 2.40 (3 H, s, C-2 Me starting material) 3.50 (3 H, s, NMe starting material) 3.56 (3 H, s, NMe reduced material) 6.75 (2 H, dxd, ring H reduced and starting materials) 8.37 (4 H, s, *p*-dinitrobenzene).

#### Inhibition study

- (c) 5-Bromo-1,2-dimethylimidazole (0.35 g, 2 mmol) in toluene (25 ml) was treated with AIBN (0.164 g, 1.0 mmol), tributyltin hydride (2.91 g, 10 mmol) and di-*t*-butyl-nitroxide (0.144 g, 1.0 mmol) as indicated in the general procedure for 48 h. Work up gave the product as a yellow oil, yield of the reduction product (0.226 g);  $\delta_{\text{H}}$  2.46 (3 H, s, C-2 Me), 2.50 (3 H, s, C-2 Me), 3.56 (3 H, s, C-2 Me), 3.67 (3 H, s, C-2 Me) and 6.85 (2 H, dxd, ring H). Analysis using n.m.r. spectroscopy with an internal standard indicated that the reaction was not completely inhibited.

#### Inhibition study

- (d) 5-Bromo-1,2-dimethylimidazole (0.35 g, 2.0 mmol) in toluene (25 ml) was treated with AIBN (0.164 g, 1.0 mmol) and tributyltin hydride (2.91 g, 10 mmol) as outlined in the general procedure for 48 h under an atmosphere of oxygen. Work up gave the product as a yellow oil, yield (0.241 g);  $\delta_{\text{H}}$  2.4 (3 H, s, C-2 Me),

2.43 (3 H, s, C-2 Me), 3.6 (3 H, s, C-2 Me) and 6.9 (2 H, dxd ring H). N.m.r. spectroscopy indicated incomplete inhibition of the reduction with traces of the starting material imidazole.

51 Reduction of 5-bromo-1,2-dimethylimidazole

5-Bromo-1,2-dimethylimidazole (0.442 g, 2.0 mmol) in toluene (25 ml) was treated with AIBN (0.164 g, 1.0 mmol) and tributyltin hydride (2.91 g, 10 mmol) as detailed in the general procedure for 48 h. Work up yielded a mixture of oil and solid materials. A yield (53%) was calculated using n.m.r. spectroscopy by the addition of an internal standard (p-dinitrobenzene);  $\delta_{\text{H}}$  2.36 (3 H, s, C-2 Me), 2.40 (3 H, s, C-2 Me), 3.6 (3 H, s, C-2 Me), 6.48 (2 H, dxd, ring H) and 8.4 (4 H, s, p-dinitrobenzene).

52 Cyclisation of 5-bromo-1-(but-3-en-1-yl)-2-methylimidazole

5-Bromo-1-(but-3-en-1-yl)-2-methylimidazole (2.0 g, 9.3 mmol) in toluene (100 ml) was treated with AIBN (0.61 g, 0.96 mmol) and tributyltin hydride (2.8 g, 9.6 mmol) as indicated in the general procedure for 72 h. Work up gave a yellow oil which was distilled at reduced pressure using a Kugelrohr apparatus to yield the imidazole (122)\* as a colourless oil (1.1 g, 87%); b.p. 95°C at 2 mmHg. (Found: C, 70.9 H, 9.0; N 20.5 C<sub>8</sub>H<sub>12</sub>N<sub>2</sub> requires C, 70.6; H, 8.8; N, 20.6);  $\nu_{\text{max}}$  (neat liquid) 2960, 2924 and 2926 (CH stretches) and 1562 (imidazole ring) cm<sup>-1</sup>;  $\delta_{\text{H}}$  1.2 (3 H, d, -CH-Me), 2.15 (3 H, s, C(2) Me), 2.5 to 3.55 (3 H, m, -CH<sub>2</sub>- and -CH-Me), 3.75 (3 H, dxt, CH<sub>2</sub>) and 6.28 (1 H, s, C(4)H); m/z 136 (M<sup>+</sup>, 58.4%), 135 (17.4) and 121 (100).

53 Attempted cyclisation of 1-allyl-5-bromo-2-methylimidazole

1-Allyl-5-bromo-2-methylimidazole (0.5 g, 2.5 mmol) in

\* 6,7-dihydro-3,7-dimethyl-5H-pyrrolo 1,2-c imidazole

toluene (40 ml) was treated with AIBN (50mg, 0.3 mmol) and tributyltin hydride (0.91 ml, 3.0 mmol) as outlined in the general procedure for 48 h. Work up yielded a yellow oil (0.334 g);  $\delta_{\text{H}}$  2.26 (3 H, s, C-2 Me) 4.4 (2H, m, NCH(2 H, dxd, ring H)) 4.75, 5.05 and 5.31 (2 H, 3xm, CH=CH<sub>2</sub>) (trans  $J_{\text{ab}}$  = 16 Hz, cis  $J_{\text{ac}}$  = 10 Hz, gem  $J_{\text{bc}}$  = 2 Hz), and 6.71 (2 H, s, ring H). The t.l.c and n.m.r. spectroscopic analysis of the material agrees with an authentic sample of the reduced compound 1-allyl-2-methylimidazole (126).

54 Reduction of 1,2-dimethyl-5-nitroimidazole

1,2-Dimethyl-5-nitroimidazole (0.141 g, 1.0 mmol) in toluene (40 ml) was treated with AIBN (33 mg, 0.2 mmol) and tributyltin hydride (0.61 ml, 2.0 mmol) as outlined in the general procedure for 48 h. Work up yielded a brown solid;  $\delta_{\text{H}}$  1.52 (s), 1.68 (s), 2.32 (s), 2.67 (s), 2.85 (s), 3.0 to 3.3 (m), 3.58 (s) and 7.1 (q). T.l.c. and n.m.r. spectroscopic analysis showed no sign of any 1,2-dimethyl-5-nitroimidazole reduced material but evidence of many highly coloured breakdown products.

55 Reduction of 1,2-dimethylimidazole

1,2-Dimethylimidazole was treated with 5 equivalents of tributyltin hydride and 0.5 equivalents of AIBN in toluene (40 ml) as outlined in the general procedure for 48 h. No reduction occurred and a virtual 100% recovery of starting material was achieved.

SECTION 7      REDUCTION REACTIONS OF HALOGENOIMIDAZOLES  
USING SODIUM/LIQUID AMMONIA AS REDUCTANT

General method for sodium/liquid ammonia reactions

The general procedure was employed unless otherwise indicated. Ammonia (160 ml) was condensed from a cylinder onto sodium metal (1 g), in a round bottomed flask fitted with a condenser using liquid nitrogen, and then redistilled into a second flask containing t-butanol (25 ml) and the required starting material. The reaction mixture was stirred under an atmosphere of nitrogen whilst a 3-fold excess of sodium metal was added giving a blue coloured solution. The reaction mixture was allowed to reflux until it became colourless whereupon ammonium nitrate followed by cold dichloromethane were added and the reaction was allowed to rise to ambient temperature. The remaining dichloromethane solution was washed with water (3 × 100 ml), dried (MgSO<sub>4</sub>), and evaporated to dryness under vacuum to give the product.

56      Reduction of 5-bromo-1,2-dimethylimidazole

5-Bromo-1,2-dimethylimidazole (0.35 g, 2 mmol) and sodium metal (0.24 g, 6 mmol) were reacted as outlined in the general procedure. The resulting blue colour persisted for 5 min. work up gave 1,2-dimethylimidazole (0.397 g) as a yellow oil. The yield of 1,2-dimethylimidazole (48%) was calculated by m.n.r. spectroscopy using p-dinitrobenzene as a internal standard.  $\nu_{\max}$  (neat liquid) 1526 (imidazole ring)  $\text{cm}^{-1}$ ;  $\delta_{\text{H}}$  2.34 (3 H, s, C-2 Me), 3.54 (3 H, s, N Me) and 6.81 (2 H, dxd, ring H).

57      Reduction of 1,2-dimethyl-5-iodoimidazole

1,2-Dimethyl-5-iodoimidazole (0.48 g, 2 mmol) and sodium metal (0.24 g, 6 mmol) were reacted as outlined in the general procedure. The blue colour persisted for about 1 min. Work up gave a yellow crystalline solid which was

found by n.m.r. spectroscopy to be a mixture of unreacted starting material and 1,2-dimethylimidazole was calculated by n.m.r. spectroscopy using *p*-dinitrobenzene as an internal standard.  $\delta_{\text{H}}$  2.32 (3 H, s, C-2 Me), 2.54 (3 H, s, C-2 Me), 3.5 (3 H, s, C-2 Me), 3.56 (3 H, s, N-Me), 6.84 (2 H, dxd, ring H), and 6.98 (1 H, s, C-4 H).

58 Reduction of 5-bromo-1-(but-3-en-1-yl)-2-methylimidazole

5-Bromo-1-(but-3-en-1-yl)-2-methylimidazole (0.43 g, 2 mmol) and sodium metal (0.24 g, 6 mmol) were reacted as outlined in the general procedure. The blue colour disappeared after 15 sec. Work up gave the cyclised imidazole product (122) as a yellow oil (0.29 g). The yield (100%) of cyclised product (122) was calculated by n.m.r. spectroscopy using *p*-dinitrobenzene as an internal standard.  $\nu_{\text{max}}$  (liquid) 2960, 2924, and 2868 (CH stretches)  $\text{cm}^{-1}$ ;  $\delta_{\text{H}}$  1.25 (3 H, s, CH-Me), 2.29 (3 H, s, C-2 Me), 2.3 to 3.6 (3 H, s, CH-CH<sub>2</sub>), 3.8 (2 H, dxt, N-CH<sub>2</sub>), and 6.55 (1 H, s, C-4 H).

59 Reduction of 1,2-dimethyl-5-nitroimidazole

1,2-Dimethyl-5-nitroimidazole (0.564 g, 4 mmol) and sodium metal (0.276 g, 12 mmol) were reacted as outlined in the general procedure giving a red coloured solution. The colour persisted throughout the reaction. Work up gave a brown solid (0.34 g) which was recrystallised from methanol to give orange crystals of 1,2-dimethyl-5-nitroimidazole (0.27g, 48% recovery of starting material); m.p. 140-142°C (methanol) (lit.,<sup>4</sup> m.p. 139-140°C).

SECTION 8      ATTEMPTED S<sub>RN</sub>1 REACTIONS WITH HALOGENOIMIDAZOLES

General procedure of S<sub>RN</sub>1 reactions

The reactions were performed under an atmosphere of dry nitrogen in flame dried glassware. The nucleophile was added to a solution of halogenoimidazole in dry DMF containing sodium hydride. The reaction vessel was irradiated (350 nm) for variable periods of time and the progress of the reaction was monitored by t.l.c. The reaction mixture was poured into water (100 ml) and extracted with diethyl ether (3 × 50 ml). The ethereal extracts were washed with water (8 × 50 ml), dried (MgSO<sub>4</sub>) and evaporated to dryness under vacuum to give the crude product.

60    Attempted preparation of 5-(diethylphosphono)-1,2-dimethyl-5-nitroimidazole

Diethylphosphite (0.65 g, 4.7 mmol), 5-bromo-1,2-dimethylimidazole 90.4 g, 2.9 mmol), sodium hydride (787 mg, 4.7 mmol) and DMF (50 ml) were reacted as outlined in the general procedure for 48 h. Work up yielded the starting material imidazole (40 mg, 6%). Repeated reaction with reaction times between 4 and 96 h also gave none of the required product but yielded only small amounts of unreacted 5-bromo-1,2-dimethylimidazole.

61    Attempted preparation of 5-(phenylthio)-1,2-dimethyl-5-nitroimidazole

(a) Phenylthiol (0.5 g, 4.5 mmol), 5-bromo-1,2-dimethylimidazole (0.4 g, 2.3 mmol), sodium hydride (80 mg, 4.5 mmol) and DMF (50 ml) were reacted as outlined in the general procedure for 34 h. Work up yielded a brown oil (0.2 g, 33%) which was chromatographed on silica gel with light petroleum/chloroform gradient elution to give a compound (0.65 g) with t.l.c., and i.r. and <sup>1</sup>H

n.m.r. spectra identical to that of diphenyl disulphide. Also isolated were traces lasting up to 48 h and with increased amounts of sodium hydride and phenyl thiol gave similar yields of only unreacted starting material and diphenyl disulphide.

- (b) Phenylthiol (0.5 g, 4.5 mmol), 1,2-dimethyl-5-nitroimidazole (0.5 g, 2.3 mmol), sodium hydride (80 mg) and DMF (50 ml) were reacted as outlined in the general procedure for 24 h. Work up yielded a brown solid (0.8 g) which was shown by t.l.c. and n.m.r. spectroscopy to be a mixture of 1,2-dimethyl-5-nitroimidazole and diphenyl disulphide.
- (c) 5-Bromo-1,2-dimethylimidazole (0.35 g, 2 mmol) and phenylthiolate (0.28 g, 2.8 mmol) were dissolved in doubly distilled liquid ammonia (50 ml) under an atmosphere of dry nitrogen and the resulting solution was irradiated (350 nm, 8 × 25 W) for 6 h at a temperature of -78°C. The ammonia was allowed to evaporate overnight giving a purple crystalline solid which was dissolved in water (50 ml) and extracted with dichloromethane (3 × 50ml). The organic extracts were dried (MgSO<sub>4</sub>) and evaporated to dryness under vacuum to give a greenish crystalline solid which became brown on standing. The solid was recrystallised from ether/light petroleum to give colourless crystals of 5-bromo-1,2-dimethylimidazole (0.33 g, 90%); m.p. 94-95°C (lit., 70-90-91°C);  $\delta_{\text{H}}$  2.36 (3 H, s, C-2 Me), 3.45 (3 H, s, C-2 Me) and 6.89 (1 H, s, C-4 H).

General procedure for preparations using n-butyl lithium

The general procedure was employed unless otherwise indicated. A solution of the imidazole in diethyl ether which had been distilled from calcium chloride and stored over sodium wire was treated with 1.1 equivalents of n-butyl lithium in hexane (8%, w/v) under an atmosphere of nitrogen at ambient temperature. The resulting anion was allowed to stand between 0.5 and 3 h after which time the required quenching agent (1 equivalent) was added and the reaction mixture allowed to stir for a variable period of time. The reactions were worked up as follows: a small quantity of methanol followed by water was added, the resulting mixture was then extracted with diethyl ether. The ethereal extracts were dried ( $\text{MgSO}_4$ ) and evaporated to dryness under vacuum to give the crude product.

62 Preparation of 1,2-dimethylimidazol-5-yl-diphenylmethanol and 1-methylimidazol-2-yl-methyldiphenylmethanol

n-Butyl lithium in hexane ( $1.75 \text{ mol dm}^{-3}$ , 14.4 ml, 23 mmol), 1,2-dimethylimidazole (2.0 g, 21 mmol) and ether (100 ml) were reacted together as outlined in the general procedure. A solution of benzophenone (4.0 g, 21 mmol) in ether (40 ml) was added dropwise and the resulting mixture was stirred for 1.5 h. Water (20 ml) was added and the reaction mixture was stirred for 10 min after which time 2 M aqueous HCl (20 ml) was added with care. The ethereal layer was separated and the aqueous layer was treated with 2 M aqueous NaOH solution until basic and no further precipitate formed. The solid (4.3 g, 71%) was dried and recrystallised from carbon tetrachloride to give 1-methylimidazol-2-yl-methyldiphenyl methanol as a colourless solid (2.1 g, 45%); m.p.  $185\text{--}186^\circ\text{C}$  (lit.,<sup>71</sup>  $186^\circ\text{C}$ );  $\delta_{\text{H}}$  3.30 (s, 3 H, Me), 3.50 (s, 2 H,  $\text{CH}_2$ ), 6.71 (d, 1 H, C-5 H), 6.85 (d, 1 H, C-4 H),



and 7.20 (m, 11 H, OH and Ph). The filtrate was evaporated to dryness under vacuum to give a solid which was repeatedly recrystallised from light petroleum (b.p. 80-100°C) and ethyl acetate to give 1,2-dimethyl-<sup>imidazol</sup>-5-yl-diphenylmethanol as an off-white solid (1.2 g, 21%); m.p. 171-172°C (lit.,<sup>71</sup> 186-187°C);  $\delta$ H 2.2 (s, 3 H, C-2 Me), 3.23 (s, 3 H, NMe), 6.1 (s, 1H, C-4 H), and 7.32 (s, 10 H, Ph). In addition, a further quantity of solid was recovered (1.0g) which was shown by n.m.r. spectroscopy and t.l.c. to be a mixture of the two isomers. The original ethereal layer was evaporated to dryness under vacuum to give benzophenone (0.9 g, 21%).

63 Attempted preparation of 1,2-dimethyl-5-nitrosoimidazole using butyl lithium

- (a) 1,2-Dimethylimidazole (1.0 g, 10.4 mmol), 8.8% n-butyl lithium solution (8.8 ml, 10.5 mmol), and isoamyl nitrite (1.5 m., 11 mmol) were reacted together as outlined in the general method. The resulting mixture was stirred for 18 h. Work up gave an orange oil as the crude product (1.226 g). N.m.r. spectroscopic analysis of the crude material showed it to contain only a mixture of starting materials.
- (b) 1,2-Dimethylimidazole (1.0 g, 10.4 mmol), 8.8% n-butyl lithium solution (8.5 m., 11 mmol), and isoamyl nitrite (1.5 ml, 10.4 mmol) were reacted together as outlined in the general procedure. The reaction mixture was refluxed for 2 h and stirred for 18 h at room temperature. Work up gave a brown oily material which was chromatographed on neutral alumina with chloroform/methanol gradient elution to give unreacted 1,2-dimethylimidazole (0.3 g) and a small quantity of an unidentified yellow/green solid (3 mg) which decomposed rapidly on standing. Repeated reactions using identical conditions gave no trace of the unidentified green

compound.

- (c) 1,2-Dimethylimidazole (1.0 g, 10.4 mmol), 8.8% n-butyl lithium solution (8.5 ml, 11 mmol), and nitrosyl sulphate (0.8 g, 5 mmol) were mixed at  $-5^{\circ}\text{C}$  resulting in a slight effervescence. The reaction was allowed to rise to ambient temperature and stirred for 2 h. Pyridine (2 ml) was added and the solution stirred overnight. The mixture was treated with saturated ammonium chloride solution, and extracted with ether (3  $\times$  100 ml). The ether extracts were dried ( $\text{MgSO}_4$ ) and evaporated to dryness under vacuum to give an orange oil. Analysis using t.l.c. and n.m.r. spectroscopy showed that the oil consisted of unreacted 1,2-dimethylimidazole and pyridine.

General Procedure: Nitrosations using sodium alkoxide and isoamyl nitrite

The general procedure was employed unless otherwise indicated. Sodium metal (1.1 equivalent) was added to the anhydrous alcohol in flame dried equipment under an atmosphere of nitrogen. The heterocycle (1.0 equivalent) was dissolved in the alkoxide solution and isoamyl nitrite (1.0 equivalent) was added via a syringe over 15 min whilst maintaining a nitrogen atmosphere. The resulting solution was stirred for between 1 and 5 days and diluted with water. The aqueous layer was extracted with diethyl ether to remove the alcohol and unreacted isoamyl nitrite, and neutralised by bubbling carbon dioxide gas through it. The precipitate produced was filtered as it formed, dried and recrystallised from a suitable solvent.

64 Preparation of 4(5)-nitroso-5(4)-phenylimidazole using alkoxides

- (a) 4-Phenylimidazole (3.0 g, 20.8 mmol), sodium (690 mg, 30 mmol) and isoamyl nitrite (3.51 g, 30 mmol) were reacted together as outlined in the general procedure with methanol (15 ml). After 24 h, half of the reaction mixture was removed by syringe and worked up as indicated, giving iridescent green crystals of 4(5)-nitroso-5(4)phenylimidazole (0.17 g, 9.3%). After a further 24 h the remaining reaction solution was worked up yielding 1.2 g (60%) of green crystals, m.p. 200-205°C (lit.,<sup>39</sup> 195-210°C [d]);  $\lambda_{max}$  (Ethanol) 240, 362, and 673 nm;  $\delta_H$  3.3 (br s, > 10 H, HOD, NH), 7.55 to 7.65 (m, 3 H, phenyl H), 8.12 (s, 1 H, C-2 [H]), and 8.4 to 8.5 (m, 2 H, phenyl H).
- (b) The above reaction was repeated with 4-phenylimidazole (5.0, 34.7 mmol), sodium methoxide (36 mmol) isoamyl nitrite (4.4 g, 34.7 mmol) in methanol (45 ml) as outlined in the general procedure. Work up gave green

crystals of 4(5)-nitroso-5(4)-phenylimidazole (5.3 g, 50%).

(d) 4-Phenylimidazole (5.0 g, 34.7 mmol), sodium ethoxide (36 mmol), isoamyl nitrite (4.4 g, 34.7 mmol) and ethanol (40 ml) were reacted together as outlined in the general procedure for 5 days. No precipitate was obtained on treatment of the aqueous phase with carbon dioxide. The ethereal extract when evaporated to dryness under vacuum yielded starting material 2.8 g (56% recovery). Repeated reactions with ethanol as solvent gave none of the expected product.

65 Attempted preparation of 5(4)-methyl-4(5)-nitrosoimidazole

4-Methylimidazole (5.0 g, 60.9 mmol), sodium (2.07 g, 90 mmol) and isoamyl nitrite (10.53 g, 90 mmol) were reacted together in methanol (30 ml) as indicated in the general method. The addition of the nitrite caused the vigorous evolution of a colourless gas. On acidification no precipitate was obtained. T.l.c. and n.m.r. spectroscopy showed extensive decomposition products.

66 Attempted preparation of 4(5)-nitroso-2-phenylimidazole

2-Phenylimidazole (5.0 g, 34.7 mmol), sodium (2 g, 38 mmol) and isoamyl nitrite (3.6 ml, 38 mmol) were reacted together in methanol (25 ml) as indicated in the general procedure for 5 days. Work up gave a dark brown/purple oil which was found to consist of decomposition products only.

67 Attempted preparation of 4(5)-nitroso-5(4)-phenylimidazole using sodium hydride as the base

An 80% dispersion of sodium hydride (0.41 g, 13.6 mmol) and 4-phenylimidazole (1.0 g, 6.94 mmol) were added to THF which had been freshly distilled from lithium aluminium hydride (40 ml) under an atmosphere of nitrogen. Isoamyl nitrite

(1.0 ml, 9.6 mmol) was added to the resulting suspension over 15 min and left to stir for 6 days. Water (150 ml) was added and the solution extracted with ether (3 × 50 ml). The ethereal extracts were combined, dried (MgSO<sub>4</sub>) and evaporated to dryness under vacuum to give an orange crystalline solid which was; shown to be starting material. A similar reaction replacing THF with DMF also yielded only starting material.

68 Attempted preparation of 2-methyl-4(5)-nitrosoimidazole

Nitrosyl sulphate (1.65 g, 13.0 mmol) was added to dry pyridine (50 ml) at -10°C giving a pale blue colour at which point 2-methylimidazole (1.0 g, 12.2 mmol) was added causing the formation of a brown colour. The solution was stirred for 2 h and water was added (pH 4-5). The solution was basified with sodium hydrogen carbonate solution and extracted with dichloromethane (3 × 1200 ml). The organic extracts were evaporated to dryness under vacuum to give a brown oil. T.l.c. and n.m.r. spectroscopic analysis showed that the oil consisted of decomposed material.

69 Attempted preparation of 2-nitrosopyrrole

Freshly distilled pyrrole (2.0 g, 30 mmol), sodium metal (1.0 g, 50 mmol), isoamyl nitrite (4.0 ml, 30 mmol), and anhydrous methanol (40 ml) were reacted together as outlined in the general procedure for one week. The progress of the reaction was monitored by t.l.c. Work up yielded only unreacted starting materials as determined by t.l.c and n.m.r. spectroscopy.

70 Attempted preparation of 2,5-dimethyl-3-nitrosopyrrole

2,5-Dimethylpyrrole (2.0 g, 21 mmol), sodium metal (0.05 g, 21 mmol), isoamyl nitrite (2.34 g, 21 mmol), and anhydrous methanol (2100 ml) were reacted together as indicated in the general procedure for 2 days. Treatment with carbon dioxide

gas gave a green solution but no solid. Extraction of the acidific aqueous phase with dichloromethane gave a green solution which darkened rapidly to a brown colour. The organic extracts were dried rapidly to a brown colour. The organic extracts were dried ( $\text{MgSO}_4$ ) and evaporated to dryness under vacuum to give a brown oil. T.l.c. and n.m.r. spectroscopic analysis showed extensive decomposition had occurred. Repeated reactions gave similar results.

71 Attempted preparation of 3-nitroso-pyrrole-2-carboxaldehyde

Pyrrole-2-carboxaldehyde (1.0 g, 10.5 mmol), sodium metal (0.28 g, 12 mmol), isoamyl nitrite 1.6 ml, 10.5 mmol), and anhydrous methanol (30 ml) were reacted together as outlined in the general method for 14 days. Work up gave only unreacted starting materials as determined by t.l.c. and n.m.r. spectroscopy,

72 Attempted preparation of 3-nitrosopyrrole-2-carboxylic acid

Pyrrole-2-carboxylic acid (1.0 g, 9.0 mmol), sodium metal (0.5 g, 21 mmol), isoamyl nitrite (1.2 ml, 9.0 mmol), and anhydrous methanol (30 ml) were reacted together as outlined in the general method for 5 days. Work up gave a colourless solid which was found by t.l.c. and n.m.r. spectroscopy to be unreacted starting material.

73 Preparation of 2-methyl-3-nitrosoindole

2-Methylindole (8.0 g, 61 mmol), sodium metal (2.0 g, 80 mmol), isoamyl nitrite (7.2 g, 61 mmol), and anhydrous methanol (150 ml) were reacted together as indicated in the general method for 43 days. Work up gave 2-methyl-3-nitrosoindole as a yellow crystalline solid (8.7 g, 99%); m.p. 190-192°C (lit.,<sup>87</sup> 191-193 °C);  $\lambda_{\text{max}}$  (ethanol) 363, and

610 (-N=O) nm;  $\nu_{\max}$  (Nujol) 3412 (br) (N-H), 1590 and 1556 (-N=O), and 1520 (aromatic ring)  $\text{cm}^{-1}$ ;  $\delta_{\text{H}}$  (360 MHz,  $\text{d}^6$ -DMSO) 2.51 (s, 3 H, C-2 Me), 7.24 (m, 1H, C-H), 7.38 (d, 2H, C-5/6H), and 7.98 (d, 1H, C-H).

74 Attempted preparation of 2-ethoxycarbonyl-3-nitroso-indole

Ethyl indole-2-carboxylate (1.0g, 5.3 mmol), sodium metal (0.14 g, 5.5 mmol), isoamyl nitrite (0.62 g, 5.5 mmol), and an anhydrous methanol (30 ml) were reacted together as outlined in the general method for 3 days. Work up gave an orange solid; (4.2 g), which was insoluble in organic solvents and water. m.p. 247-248°C(d);  $\lambda_{\max}$  (ethanol) 207, 263 and 323 nm;  $\nu_{\max}$  (Nujol) 3230 (br) (N-H), 1850, 1600, and 1510 (aromatic ring)  $\text{cm}^{-1}$ ;  $\delta_{\text{H}}$  (360 MHz,  $\text{d}^6$ -DMSO) 7.31-8.27 (mxm, 9 H, aromatic H);  $\delta_{\text{C}}$  (360 MHz,  $\text{d}^6$ -DMSO) 119.742, 120.646, 126.127, 127.223, 128.500, 129.449, 130.883, 131.144, 132.046 (aromatic ring), 154.186 and 171.865 (C-2/3). The product appears to exist as the oxime (161).

#### General procedure: nitrosations using nitrous acid

An aqueous solution of sodium nitrite was cautiously added to glacial acetic acid at a temperature of  $-10^{\circ}\text{C}$ , giving a pale blue solution of nitrous acid. The heterocycle was added to a large excess of the nitrous acid at  $-5$  to  $-10^{\circ}\text{C}$  and was allowed to stir from up to 1 h. The resulting mixture was poured into water giving a precipitate which was separated, dried and purified by column chromatography or recrystallisation as appropriate.

#### 76 Preparation of 1-methyl-3-nitroso-2-phenylindole

1-Methyl-2-phenylindole (2 g, 9.9 mmol) was reacted with excess nitrous acid as outlined in the general procedure for 1h. Work up gave a green precipitate (2 g, 88%) which was purified by flash column chromatography with silica as absorbent using chloroform/light petroleum (b.p.  $40-60^{\circ}\text{C}$ ) gave green crystals (0.2 g, 8%) of 1-methyl-3-nitroso-2-phenylindole; m.p.  $143^{\circ}\text{C}$ (lit.,<sup>98</sup>  $144^{\circ}\text{C}$ );  $\lambda_{\text{max}}$  (ethanol) 632 nm;  $\nu_{\text{max}}$  (nujol) 1540 ( $-\text{N}=\text{O}$ )  $\text{cm}^{-1}$ ;  $\delta_{\text{H}}$  (360 MHz,  $\text{d}_6$ -DMSO) 3.88 (s, 3 H, NMe), 7.44 to 8.14 (qxm, 9 H, aromatic ring-H);  $\delta_{\text{C}}$  (360 MHz,  $\text{d}_6$ -DMSO) 32.065 (NMe), 11.157 and 112.480 (C7 and C-NO), 120.217, 126.103, 127.233, 127.748, 128.310, 130.512 and 131.871 (aromatic ring), 136.166 (C-8), and 156.388, 157.023 (C-2 and C-7a).

#### 77 Attempted preparation of 1,2-dimethyl-3-nitrosoimidazole

1,2-Dimethylindole (2 g, 13.8 mmol) was reacted with excess nitrous acid for 30 min as outlined in the general procedure. Work up gave a brown solid which was shown by t.l.c. and n.m.r. spectroscopy to consist of a number of compounds. Attempts isolate the required nitrosoindole by chromatography and recrystallisation proved unsuccessful.



78 Attempted preparation of 2-ethoxycarbonyl-1-methyl-3-nitrosoindole

2-Ethoxycarbonyl-1-methylindole (2 g, 1.0 mmol) was reacted with excess nitrous acid as outlined in the general procedure for 1 h. Work up gave a cream-coloured crystalline compound (2 g) which was shown by t.l.c and n.m.r. spectroscopy to be unreacted starting material.

79 Attempted preparation of 1-methyl-2-nitrosopyrrole

1-Methylpyrrole (1 ml) was added to excess nitrous acid as outlined in the general procedure. The reaction mixture turned black immediately and subsequent analysis by t.l.c. and n.m.r. spectroscopy of the product showed it to consist of intractable black polymeric and decomposition products.

80 Attempted preparation of 1,2-dimethyl-5-nitrosoimidazole

1,2-Dimethylimidazole (0.5 g) was reacted with excess nitrous acid as outlined in the general procedure. Work up gave only unreacted starting materials.

81 Preparation of 1-methyl-5-nitroso-4-phenylimidazole using diazomethane

(a) A 1% solution of diazomethane (100 ml, 1.4 equivalents) was added to a suspension of 4(5)-nitroso-5(4)-phenylimidazole (3.0 g, 17.3 mmol) in anhydrous ether (150 ml) whilst cooling on ice. The reaction mixture was stirred for 10 min until no solid remained and the ether was removed under vacuum. The resulting solid was immediately chromatographed using silica gel as absorbent with chloroform as the eluent to give a green fraction which was evaporated to dryness under vacuum. The green solid produced was recrystallised from light petroleum (b.p. 80-100°C) to give bright green crystals of 1-methyl-5-nitroso-4-phenylimidazole (1.7 g, 55%); m.p. 148-149°C (lit.,<sup>39</sup> 128-130°C) (Found: C, 64.3; H,

4.9; N 22.5.  $C_{10}H_9N_3O$  requires C, 64.2; H, 4.8; N, 22.5%;  $\lambda_{max}$  (EtOH) 707 (-N=O) nm;  $\nu_{max}$  (nujol) 1534 (-N=O str)  $cm^{-1}$ ;  $\delta_H$  (360 MHz,  $d_6$ -DMSO) 3.57 (s, 3H, NMe), 7.55 (m, 3 H, Ph and C-2 H), 8.18 and 8.38 (m, 2 H, Ph);  $\delta_C$  (360 MHz,  $d_6$ -DMSO) 34.91 (q, NMe), 128.82, 129.39, and 130.50 (3xd, Ph C-2, C-3, and C-4), 131.67 (s, Ph C-1), 144.78 (d, C-2), 155.30 (br s, C-5[NO]), and 159.37 (s, C-4[Ph]).  $m/z$  187.07 ( $M^+$  56.81%) 186.06 (17.15), 159.08 (26.57, and 104.05 (18.76). Repeat reaction employing anhydrous THF as solvent, longer reaction times or lower temperatures resulted in inferior yields.

(b) Using methyl iodide

4(5)-Nitroso-5(4)-phenylimidazole (200 mg, 1.15 mmol) was added to a suspension of anhydrous potassium carbonate (104 mg, 1.2 mmol) in anhydrous distilled acetone (25 ml). Methyl iodide (0.1 ml, 228 mg, 1.6 mmol) was added and the resulting mixture was filtered. The filtrate was evaporated to dryness under vacuum to give a brown solid which was then sublimed under reduced pressure using a kugelrohr apparatus (0.1 mmHg, 10 °C) to give 1-methyl-5-nitroso-4-phenylimidazole as a green solid (20 mg, 7%);  $\delta_H$  (360 MHz  $d_6$ -DMSO) 3.65(s, 3 H, NMe), 7.4 to 7.6 (m, 3 H, Ph), 7.52 (s, 1 H, C-2[H]), and 8.49; (m, 2 H, Ph);  $m/z$  187.074 ( $M^+$ , 85.71%).

(c) Using methyl p-toluenesulphonate

4(5)-Nitroso-(5)4-phenylimidazole (100 mg, 0.58 mmol) and methyl- p-toluenesulphonate (700 mg, 4.0 mmol) were heated together under an atmosphere of nitrogen at 120°C for 1h. After cooling the reaction mixture was diluted with saturated sodium hydrogen carbonate solution and extracted with dichloromethane (3 x 50ml). The dichloromethane was dried ( $MgSO_4$ ) and evaporated to dryness under vacuum to give a red oil. T.l.c. analysis

showed the presence of starting materials only.

82 Attempted preparation of 1,2-dimethyl-3-nitrosoindole

Anhydrous potassium hydroxide (0.36 g, 12.5 mmol) was partially dissolved in dry distilled DMSO (15 ml) over a 15 min period. 2-Methyl-3-nitrosoindole (1.0 g, 6.25 mmol) was added giving a deep green solution which was stirred for 1 h during which time the colour changed to deep red. Methyl iodide (0.44 ml, 6.25 mmol) was added dropwise whilst cooling the reaction mixture in ice, resulting in a green/brown solution. After stirring for 1 h, water (30 ml) was added and the aqueous solution was extracted with ether (3 × 50 ml). The ether~~al~~ solution was dried (MgSO<sub>4</sub>) and evaporated to dryness under vacuum to give a red oil. The oil was triturated with light petroleum/ether to give a brown solid which was filtered and dried. T.l.c., i.r., u.v., and n.m.r. spectroscopic analysis indicated none of the required nitroso compound to be present.

83 Reaction between p-aminotoluene and nitrosobenzene

A few drops of acetic acid were added to a cooled, stirred solution of p-aminotoluene (0.1 g, 0.94 mmol) and nitroso benzene (0.1 g, 0.94 mmol) in absolute ethanol (20 ml). The resulting blue coloured solution was stirred at 0-5°C for 1h. The solution was allowed to warm to ambient temperature, and stirred for a further 18 h. The progress of the reaction was monitored by t.l.c. The orange reaction mixture was evaporated to dryness under vacuum to give an orange solid which was recrystallised from aqueous ethanol to yield 1-phenyl-2-(p-tolyl)diazene (0.18 g, 90%); m.p. 71-72°C (lit.,<sup>94</sup> 71-72°C);  $\lambda_{\max}$  (ethanol) 439, 323, and 230 nm.

84 Reaction between 9-benzyladenine and nitrosobenzene

- (a) A few drops of acetic acid were added to a solution of 9-benzyladenine (0.1 g, 0.44 mmol) and nitrosobenzene (50 mg, 0.44 mmol) in absolute ethanol (75 ml) and the resulting solution was stirred at ambient temperature for 1 h. The solution was heated under reflux for 120h. The solvent was removed under vacuum to give an orange solid which was recrystallised from ethanol;  $\lambda_{\max}$  (ethanol) 356, and 271nm. There was no sign of a diazene absorption at about 440nm in the u.v. spectrum. T.l.c. indicated that a number of orange compounds were present although attempted separation by column chromatography was unsuccessful.
- (b) 9-Benzyladenine (0.2 g, 3.74 mmol) was added to a 50% aqueous sodium hydroxide solution (10 ml) at 50°C. Toluene (0.5 ml) and nitroso benzene (0.4 g, 3.74 mmol) were added and the resulting mixture was stirred for 2 h. After cooling the mixture was extracted with toluene (3 × 15 ml). The toluene extracts were evaporated to

dryness under vacuum. The residue was chromatographed on alumina with toluene as eluent to yield a yellow oil;  $\lambda_{\max}$  (ethanol) 381, and 230nm. No evidence of a diazene group being present in the product was observed using u.v. spectroscopy.

85 Reaction between p-aminotoluene and 4(5)-nitroso-5(4)-phenylimidazole

- (a) A few drops of acetic acid were added to a solution of 4(5)-nitroso-5(4)-phenylimidazole (0.1g, 0.58 mmol) and p-aminotoluene (62 mg, 0.58 mmol) in absolute ethanol (70 ml) and stirred at ambient temperature for 16h. The solvent was removed under vacuum to give an orange solid which was chromatographed on silica gel with light petroleum (b.p. 40-60°C)/chloroform gradient elution to yield an orange solid (5 mg);  $\lambda_{\max}$  (ethanol) 455, and 239 nm. Although the u.v. spectroscopic analysis indicates the presence of a diazene functional group, we were unable to further identify the orange material.
- (b) A solution of 4(5)-nitroso-5(4)-phenylimidazole (100 mg, 0.58 mmol) and p-aminotoluene (62 mg, 0.58 mmol) in anhydrous ethanol (50 ml) was stirred for 24 h. Aqueous 2M HCl (2 drops) was added causing the green coloured solution to become orange. The reaction mixture was sealed under an atmosphere of nitrogen and allowed to stand for 48 h. The solvent was removed under vacuum to give a brown residue. T.l.c., u.v. and n.m.r. spectroscopy indicated that the residue consisted of unreacted starting materials with traces of decomposition products.

86 Reaction between 4-aminopyridine and nitrosobenzene

4-Aminopyridine (1.0 g, 13.5 mmol) was added to 50% aqueous sodium hydroxide solution (10 ml) at 60°C. Toluene (0.5 ml)

and nitrosobenzene (1.0 g, 13.5 mmol) were added with stirring and the reaction mixture was heated at 60°C for 3 h. After cooling; the reaction mixture was extracted with toluene (3 × 15 ml). The toluene extracts were evaporated to dryness under vacuum. The residue was chromatographed on alumina with toluene as eluent to give an orange solid which was recrystallised from n-pentane to yield red crystals of 1-phenyl-2-(4-pyridinyl)-diazene (173) (60 mg) 3%; m.p. 96°C (lit.,<sup>95</sup> 98°C);  $\lambda_{max}$  (ethanol) 430, 321 and 224 nm.

87 Reaction between 2-aminopyridine and nitrosobenzene

2-Aminopyridine (0.5 g, 6.76 mmol) was added to warm (45°C) 50% aqueous sodium hydroxide solution (5 ml) and the resulting mixture warmed at 50°C. Benzene (0.5 ml) and nitrosobenzene (0.6 g, 6.76 mmol) were added with vigorous stirring over 10 min and the temperature raised to 60°C for 15 min. After cooling the reaction mixture was extracted with benzene (3×10 ml). The benzene extracts were evaporated to dryness under vacuum and the resulting residue chromatographed on alumina with toluene eluent to yield an orange fraction which on evaporation to dryness under vacuum gave an orange solid. Recrystallisation from light petroleum (b.p. 40-60°C) gave red crystals of 1-phenyl-2-(2-pyridinyl)-diazene (172) (0.6 g, 62%); (m.p. 51-52°C (lit.,<sup>95</sup> 52-53°C);  $\lambda_{max}$  (ethanol) 442, 318, and 223 nm.

88 Reaction between 4(5)-nitroso-5(4)-phenylimidazole and 2-hydroxypyridine

A solution of 4(5)-nitroso-5(4)-phenylimidazole (100 mg, 0.58 mmol) and 2-hydroxypyridine (55 mg, 0.58 mmol) in anhydrous methanol (40 ml) was stirred at room temperature for 2 h. Aqueous 2 M HCl (2 drops) was added causing a rapid change in colour from green to orange. After 10 min, the solvent was removed under vacuum to give brown residue. T.l.c. and n.m.r. spectroscopy indicated that the residue

consisted of unreacted nitrosoimidazole and the keto isomer of the hydroxypyridine.

89 Preparation of 9-benzyladenine

Adenine (2 g, 15 mmol), benzylchloride (3.8 g, 30 mmol), and potassium carbonate (2 g, 5 mmol) were suspended in anhydrous DMF (220 ml) and heated at 110°C for 16 h. The resulting mixture was cooled, filtered, and the filtrate was reduced under vacuum to give a yellow solid which was recrystallised from ethanol/charcoal to give 9-benzyladenine as a colourless crystalline solid (0.7 g, 29%); m.p. 229-230°C (lit.,<sup>96</sup> 233-235°C);  $\nu_{\max}$  (Nujol) 3396 (N-H), 1642 (C=O), and 1596, 1570 (aromatic ring)  $\text{cm}^{-1}$ .

90 Attempted preparation of 9-benzylguanine

A suspension of guanine (1 g, 7.5 mmol), benzylchloride (1.9 g, 15 mmol), and potassium carbonate (1 g, 7.5 mmol) in anhydrous DMF (100 ml) was heated at 120°C for 24 h. The solvent was removed under vacuum to yield an off-white solid (2.8 g). T.l.c., i.r. and n.m.r. spectroscopy indicated that the residue contained only unreacted starting materials.

91 Attempted preparation of 1-methylcytosine

Cytosine (2.5 g, 19.4 mmol) was dissolved in a solution of DMSO (25 ml), water (25 ml), and potassium hydroxide (1.1 g, 19 mmol). Methyl iodide (3.0 g, 21 mmol) was added to the resulting solution which was stirred for 48 h. The white precipitate formed was filtered and recrystallised from ethanol. T.L.C., i.r. and n.m.r. spectroscopy indicated that the solid consisted of unreacted cytosine.

SECTION 11      REACTIONS BETWEEN THIOLS AND NITROSO-  
HETEROCYCLES

General Procedures for reactions between thiols and nitroso-  
heterocycles

The general procedure was followed except where otherwise indicated. The nitroso-heterocycle was added to dry distilled solvent under an atmosphere of nitrogen. The thiol (1 equivalent) was added to the solution of the nitroso-heterocycle and the resulting solution allowed to stir under an atmosphere of nitrogen for different lengths of time. The progress of the reaction was monitored using t.l.c. The solvent was removed under vacuum to give the crude reaction product.

92    Reaction between 4(5)-nitroso-5(4)-phenylimidazole and  
p-chlorothiophenol

- (a) 4(5)-Nitroso-5(4)-phenylimidazole (53 mg, 0.3 mmol) and p-chlorothiophenol (44 mg, 0.3 mmol) in ether (30 ml) were reacted as outlined in the general procedure for 20 h. Work up gave a dark red solid (97 mg),  $\lambda_{\max}$  (ethanol) 491, 305, 242 and 212;  $\delta_{\text{H}}$  7.1 to 7.8 (m, aromatic ring H). The red solid was chromatographed with silica gel as absorbent using dichloromethane/light petroleum (b.p. 40-60°C) as the eluent. The disulphide of p-chlorothiophenol was recovered as a colourless oil (29 mg, 70%);  $\nu_{\max}$  (neat liquid) 2920, 2850 (C-H aromatic), 1656, 1464, 1378, 1092 and 816 (p-disubstituted aromatic ring)  $\text{cm}^{-1}$ ;  $\delta_{\text{H}}$  7.32 (d x d, 4 H, unsymmetrical p-disubstituted ring).
- (b) 4(5)-Nitroso-5(4)-phenylimidazole (100 mg, 0.58 mmol) and p-chlorothiophenol (83 mg, 0.58 mmol) in THF (25 ml) were reacted as outlined in the general procedure for 30 min. Work up yielded a red solid (183 mg);  $\delta_{\text{H}}$  6.9 to 7.55 (m, aromatic ring H), 7.1 (s, aromatic),



and 7.35 (d, aromatic ring H).

- (c) 4(5)-Nitroso-5(4)-phenylimidazole (200 mg, 1.16 mmol) and p-chlorothiophenol (170 mg, 1.16 mmol) in THF (40 ml) were reacted at  $-15^{\circ}\text{C}$  but as outlined in the general procedure. After 30 min the reaction was terminated and work up yielded a red solid (370 mg);  $\delta_{\text{H}}$  6.7 to 7.7 (m, aromatic ring).

93 Reaction between 4(5)-Nitroso-5(4)-phenylimidazole and ethyl mercaptoacetate

- (a) 4(5)-Nitroso-5(4)-phenylimidazole (100 mg, 0.58 mmol) and ethyl mercaptoacetate (70 mg, 0.58 mmol) in ether (40 ml) were reacted as outlined in the general procedure, initially at  $-10^{\circ}\text{C}$  for 30 min, then at ambient temperature for 42 h. Work up yielded a brown solid (170 mg)  $\delta_{\text{H}}$  1.31 (t, 6 H, Me), 3.60 (2, 4 H, S-CH<sub>2</sub>), 4.20 (g, 4 H, CH<sub>2</sub>-Me), and 7.1 to 7.8 (br, m, imidazole residue).
- (b) 4(5)-Nitroso-5(4)-phenylimidazole (200 mg, 1.16 mmol) and ethyl mercaptoacetate (280 mg, 2.32 mmol) in ether (40 ml) were reacted as outlined in the general procedure initially at  $-15^{\circ}\text{C}$  for 30 min and then at ambient temperature for 12 days. Work up yielded a brown solid which was chromatographed using neutral alumina with chloroform as eluent to give disulphide (182) (263 mg, 92%) as a yellow oil;  $\nu_{\text{max}}$  (neat liquid) 1730, 1286 and 1030  $\text{cm}^{-1}$ ;  $\delta_{\text{H}}$  1.30 (t, 6 H, CH<sub>3</sub>), 3.65 (s, 4 H, S-CH<sub>2</sub>), and (q, 4 H, CH<sub>2</sub>-Me). The t.l.c., i.r. and n.m.r. spectra were identical with those of authentic material.
- (c) 4(5)-Nitroso-5(4)-phenylimidazole (100 mg, 0.58 mmol) and ethyl mercaptoacetate (69 mg, 0.58 mmol) in methanol (40 ml) were reacted as outlined in the general procedure for 18 h. Work up yielded a

red/brown solid which was chromatographed using neutral disulphide as absorbent with chloroform as eluent to give the disulphide (182) (42 mg, 61%);  $\nu_{\max}$  (neat liquid) 1730, 1286 and 1030  $\text{cm}^{-1}$ ;  $\delta_{\text{H}}$  1.30 (t, 6H, Me), 3.40 (s, 4 H, S-CH<sub>2</sub>), 4.24 (q, 4 H, CH<sub>2</sub>-Me) 6.4 (br, s, CH<sub>2</sub> imidazole ring). The t.l.c., i.r. and n.m.r. spectra were identical with those of authentic material.

- (d) 4(5)-Nitroso-5(4)-phenylimidazole (100 mg, 0.58 mmol) and ethyl mercaptoacetate (69 mg, 0.58 mmol) in methanol (30 ml) were reacted as outlined in the general procedure for 1 h. Work up yielded a brown solid (85 mg). An accurate yield of (61%) disulphide (182) was obtained using n.m.r. spectroscopy with *p*-dinitrobenzene as an internal standard;  $\delta_{\text{H}}$  1.29 (t, 6 H, Me), 3.6 (s, 4 H, S-CH<sub>2</sub>), 4.25 (q, 4 H, CH<sub>2</sub>-Me), 7.4 (i, imidazole residue), and 8.5 (s, *p*-dinitrobenzene).
- (e) 4(5)-Nitroso-5(4)-phenylimidazole 100 mg, 0.58 mmol) ethyl mercaptoacetate (69 mg, 0.58 mmol) in methanol (40 ml) were reacted as outlined in the general procedure. The progress of the reaction was monitored by t.l.c., and after 24 h no starting material imidazole remained.
- (f) 4(5)-Nitroso-5(4)-phenylimidazole (100 mg, 0.58 mmol) was added to a solution of sodium ethoxide (40 mg, 0.58 mmol) and ethyl mercaptoacetate (69 mg, 0.58 mmol) in anhydrous ethanol (40 ml) resulting in a deep green solution. The reaction was monitored by t.l.c. and gradually became yellow/brown in colour. After 3 days, the reaction was worked up as outlined in the general procedure to give a brown solid. T.l.c. indicated that at no time during the course of the reaction was any of the disulphide (182) formed. T.l.c. and n.m.r. spectroscopic analysis of the final product showed none of the

expected disulphide (182) only imidazole decomposition products and unreacted ethyl mercaptoacetate .

94 Reaction between 4(5)-nitroso-5(4)-phenylimidazole and N-acetylcysteine

4(5)-Nitroso-5(4)-phenylimidazole (200 mg, 1.16 mmol) and N-acetylcysteine (188 mg, 1.16 mmol) in methanol (40 ml) were reacted as outlined in the general procedure for 48 h. A colour change from green to orange was observed after 15 min although t.l.c. analysis showed the presence of the imidazole starting material even after 48 h. Work up gave the disulphide of N-acetylcysteine (187) as a brown solid (380 mg);  $\delta_{\text{H}}$  2.0 (br.s, 6 H, -COMe). 3.3 (s, 4 H, SCH<sub>2</sub>), 4.85 (m, 2 H, CH), and 8.5 (s, p-dinitrobenzene).

95 Reaction between 1-methyl-5-nitroso-4-phenylimidazole and p-chlorothiophenol

1-Methyl-5-Nitroso-4-phenylimidazole (50 mg, 0.27 mmol) and p-chlorothiophenol (38 mg, 0.27 mmol) in ether (30 ml) were reacted as outlined in the general procedure for 5 days. Work up yielded a green/brown solid,  $\delta_{\text{H}}$  3.6 (s), 7.1 to 7.8 (m) and 8.5 (m). The <sup>1</sup>H n.m.r. spectrum and the t.l.c indicated the presence of unreacted 1-methyl-5-nitroso-4-phenylimidazole and di-p-chlorophenyl disulphide.

96 Reaction between 1-methyl-5-nitroso-4-phenylimidazole and ethyl mercaptoacetate

(a) 1-Methyl-5-nitroso-4-phenylimidazole (50 mg, 0.27 mmol) and ethyl mercaptoacetate (68 mg, 0.6 mmol) in ether (40 ml) were reacted as outlined in the general procedure initially at -10°C for 30 min, and then at ambient temperature for 18 h. Work up yielded a brown solid (115 mg) which was chromatographed using neutral alumina as absorbent with chloroform as eluent to give the disulphide (182) (52 mg, 36%);  $\delta_{\text{H}}$  1.29 (t, 6 H, Me), 3.62 (s, 4 H, S-CH<sub>2</sub>). The t.l.c., i.r. and n.m.r.

spectra were identical to those of authentic material.

- (b) 1-Methyl-5-nitroso-4-phenylimidazole (100 mg, 0.54 mmol) and ethyl mercaptoacetate (64 mg, 0.54 mmol) in methanol (30 ml) were reacted as outlined in the general procedure for 30 min. Work up gave a brown oily solid (164mg). An accurate yield of the disulphide (182) (84%) was calculated using n.m.r. spectroscopy with *p*-dinitrobenzene as internal standard;  $\delta_H$  1.28 (t, 6 H, Me), 3.61 (s, 4 H, S-CH<sub>2</sub>), 4.24 (q, 4 H, CH<sub>2</sub>-Me), 7.35 (m, imidazole residue), and 8.5 (s, *p*-dinitrobenzene).
- (c) 1-Methyl-5-nitroso-4-phenylimidazole (100 mg, 0.54 mmol) and ethyl mercaptoacetate (64 mg, 0.54 mmol) in methanol (30 ml) were reacted together as outlined in the general procedure. The progress of the reaction was monitored using t.l.c. and after 10 min all the imidazole starting material had been consumed.
- (d) 1-Methyl-5-nitroso-4-phenylimidazole (50 mg, 0.27 mmol) was added to a solution of sodium ethoxide (12 mg, 0.3 mmol) and ethyl mercaptoacetate (32 mg, 0.27 mmol) in anhydrous ethanol (30 ml). After 20 min none of the imidazole starting material remained. The reaction mixture was worked up as outlined in the general procedure to give a brown solid (75 mg). T.l.c., i.r. and n.m.r. spectroscopy indicated that none of the expected disulphide had been formed and that the residue consisted of numerous imidazole decomposition products and unreacted ethylmercaptoacetate .

97 Reaction between 1-methyl-5-nitroso-4-phenylimidazole and N-acetylcysteine

1-Methyl-5-nitroso-4-phenylimidazole (100 mg, 0.58 mmol) and N-acetylcysteine (87 mg, 0.58 mmol) in methanol (40 ml) were reacted as outlined in the general procedure for 48 h. A

colour change from green to orange was observed after 15 min. The progress of the reaction was monitored by t.l.c. Work up gave a brown solid (168 mg). An n.m.r. yield (79%) of disulphide (187) was obtained using *p*-dinitrobenzene as internal standard;  $\delta_{\text{H}}$  1.9 (s, 6 H, COMe), 3.28 (s, 4 H, SCH<sub>2</sub>), 3.4 (br. s, OMe in methanol adduct), 4.8 (m, 2 H, CH), 6.2 (br. s, C-2 H in methanol adduct), 7.45 (br. m, imidazole ring residue), and 8.5 (s, *p*-dinitrobenzene).

98 Reaction between 2-methyl-3-nitrosoindole and ethylmercaptoacetate

2-Methyl-3-nitrosoindole (67 mg, 0.84 mmol) in the form of the dimer (162) and ethyl mercaptoacetate (100 mg, 0.84 mmol) in methanol (40 ml) were reacted as outlined in the general procedure. The solution changed from green to orange over 24 h. After 36 h the reaction mixture was worked up, although t.l.c. analysis showed traces of unreacted indole starting material, to give a brown solid (158 mg). An n.m.r. yield (100 %) of disulphide (182) was obtained using *p*-dinitrobenzene as internal standard;  $\delta_{\text{H}}$  1.15 (t, Me), 1.3 (t, 6 H, Me), 2.55 (s), 3.65 (s, 4 H, S-CH<sub>2</sub>). 4.2 (q, 4 H, CH<sub>2</sub>-Me), 7.3 (m, imidazole ring residues), and 8.5 (s, *p*-dinitrobenzene).

99 Reaction between 2-methyl-3-nitrosoindole and N-acetylcysteine

2-Methyl-3-nitrosoindole (100 mg, 0.63 mmol) and N-acetylcysteine (102 mg, 0.63 mmol) in methanol were reacted as outlined in the general procedure for 36 h. The reaction mixture turned orange after 30 min. The progress of the reaction was monitored by t.l.c. which showed traces of unreacted indole starting material after 36 h. Work up gave a brown solid (190 mg). An accurate yield (53%) of disulphide (1887) was obtained using *p*-dinitrobenzene as internal standard  $\delta_{\text{H}}$  1.95 (s, 6 H, COMe), 3.25 (s, 4 H,

SCH<sub>2</sub>), 4.84 (m, 2 H, CH), and 8.5 (s, p-dinitrobenzene).

100 Reaction between 1,2-dimethyl-5-nitroimidazole and ethyl mercaptoacetate

- (a) 1,2-Dimethyl-5-nitroimidazole (0.5 g, 3.55 mmol) and ethyl-2-mercaptoacetate (0.43 g, 3.55 mmol) in ether (50 ml) were reacted as outlined in the general procedure for 14 days. The progress of the reaction was monitored by t.l.c. Work up gave a colourless solid which was shown by t.l.c. and n.m.r. spectroscopy to consist of unreacted starting materials. No disulphide was observed.
- (b) 1,2-Dimethyl-5-nitroimidazole (100 mg, 0.7 mmol) and ethyl mercaptoacetate (85 mg, 0.7 mmol) in methanol (30 ml) were reacted as outlined in the general procedure for 14 days. The progress of the reaction was monitored by t.l.c. Work up gave a colourless solid which was shown by t.l.c. and n.m.r. spectroscopy to consist of unreacted starting materials. No disulphide was observed.
- (c) 1,2-Dimethyl-5-nitroimidazole (100 mg, 0.7 mmol) was added to a solution of sodium ethoxide (16 mg, 0.7 mmol) and ethyl mercaptoacetate (85 mg, 0.7 mmol) in anhydrous ethanol (30 ml). After 7 days, t.l.c. showed the presence of unreacted starting materials only. No disulphide was observed.

101 Reaction between 4(5)-nitroso-5(4)-phenylimidazole and methanol

4(5)-Nitroso-5(4)-phenylimidazole (50 mg, 0.29 mmol) was dissolved in anhydrous methanol (25 ml), sealed, and allowed to stand for 7 days. The solvent was removed under vacuum to give a brown solid (62 mg, 100%);  $\delta_{\text{H}}$  (360 MHz) 3.24 (s, 3 H, OMe), 6.32 (s, 1 H, C-2 H), 7.48 (m, 3 H, m- and p-

positions in phenyl ring), and 8.24 to 8.28 (m, 3 H, NH and *o*-positions in phenyl ring). The n.m.r. spectra agreed with that in the literature.

#### 102 Preparation of the disulphide of ethyl mercaptoacetate

A solution of iodine (11.8 g, 33.4 mmol) and potassium iodide (5.54 g, 33.4 mmol) in water (80 ml) was added dropwise to a solution of sodium hydroxide (0.8 g, 20 mmol) and ethyl mercaptoacetate (2.0 g, 16.7 mmol) in water (50 ml) until some of the iodine colour persisted. The solution was extracted with ether (3 × 50 ml). The ether extracts were washed with sodium thiosulphate solution (100 ml), water (100 ml), dried (MgSO<sub>4</sub>), and evaporated to dryness to give the pure disulphide as pale yellow oil (1.8 g, 90%);  $\nu_{\max}$  (neat liquid) 2980 (C-H str.), 1732 (C=O str.), 1464, 1444, 1402, 1366, 1288 and 1028 cm<sup>-1</sup>;  $\delta_{\text{H}}$  1.29 (t, 6 H, CH<sub>2</sub>-CH<sub>3</sub>), 3.65 (s, 4 H, S-CH<sub>2</sub>-), and 4.25 (q, 4 H, CH<sub>2</sub>-CH<sub>3</sub>).

## REFERENCES

- 1 D.I. Edwards and G.E. Mathison. The Mode of Action of Metronidazole Against *Trichomonas Vaginalis*, J. Gen. Microbiol., 1970, 63, 297
- 2 D.I. Edwards, M. Dye, and H. Carre, The Selective Toxicity of Antimicrobial Nitroheterocyclic Drugs, J. Gen. Microbiol., 1973, 76, 135.
- 3 Nitroimidazoles: Chemistry, Pharmacology and Clinical Applications, eds, A. Breccia, B. Cavalleri, and G.E. Adams, Plenum Press, New York, 1982.
- 4 R.J. Knox, R.C. Knight, and D.I. Edwards, Biochem. Pharmacol., 1983, 32, 2149.
- 5 R.C. Knight, I.M. Skolimowski, and D.I. Edwards, Biochem. Pharmacol., 1978, 27, 2089.
- 6 N.F. LaRusso, M. Tomaz, M. Muller, and R. Lipman, Mol. Pharmacol., 1977, 13, 872.
- 7 R.M. Ings, J.A. McFadzean, and W.E. Ormerod, Biochem. Pharmacol., 1974, 23, 745.
- 8 N.F. LaRusso, M. Tomaz, D. Kaplan and M. Muller, Antimicrob. Agents Chemother., 1978, 13, 19.
- 9 P.J. Declerk, C.J. De Ranter, and G. Volckaert, FEBS Lett., 1983, 164, 145.
- 10 D.I. Edwards, Prog. M. Chem., 1981, 18, 87.
- 11 D.I. Edwards, Br. J. Vener. Dis., 1980, 56, 285.
- 12 P.L. Olive in "Radiation Sensitisers: Their Use in the Clinical Management of Cancer", ed. L.W. Brady, Masson Publications, New York, 1980, p.39.
- 13 D.I. Edwards, Biochem. Pharmacol., 1986, 35 53.
- 14 D.I. Edwards, R.J. Knox, D.A. Rowley, I.M. Skolimowski, and R.C.Knight, NATO Adv. Study Inst. Ser.A. 1982, 42, 105.
- 15 P.L. Olive, Br. J. Cancer, 1979, 40, 94.
- 16 D.A. Rowley, R.C. Knight, I.M. Skolimowski, and D.I. Edwards, Biochem. Pharmacol., 1979, 28 3009.



- 17 P.J. Declerck and C.J. Ranter, Biochem. Pharmacol., 1986, 35, 60.
- 18 G.L. Kedderis and G.T. Miwa, Drug Metabolism Reviews. 1988, 1, 33.
- 19 G.T. Miwa, L.S. Argentbright, and G.L. Kedderis, The Toxicologist, 1987, 7, 6.
- 20 S.B. Best, P.G. Wislocki, F.J. Wolf, and A.Y.H. Lu, Chem.-Biol. Interact., 1982, 41, 297.
- 22 C.J. Coulson, "Molecular Mechanics of Drug Action", Taylor and Francis, London, 1988, pp.55-60.
- 23 M.D. Nair and K. Nagarajan, Progress in Drug Research, Birkhauser Verlag, Basel, 1983.
- 24 C.E. Sullivan, F.P. Tally, B.R. Golding, P. Vouros, Biochem. Pharmacol., 1982, 31, 2689
- 25 R.L. Koch, C. Rose, T.A. Rich, and F. Goldman, Biochem. Pharmacol., 1982, 31, 411.
- 26 B.R. Smith and J.L. Born, Int. J. Radiat. Oncol. Biol Phys., 1984, 10, 1365.
- 27 R.A. McClelland, J.R. Fuller, N.E. Seaman, A.M. Rauth, and R. Battistella, Biochem. Pharmacol., 1984, 33, 303.
- 28 J.A. Raleigh and S.F. Liu, Biochem. Pharmacol., 1983, 32, 1444.
- 29 A.J. Varghese and G.F. Whitmore, Cancer Res., 1983, 43, 78.
- 30 A.J. Varghese, Biochem. Biophys. Res. Commun., 1983, 112, 1013.
- 31 R.A. McClelland, R. Panicucci, and A.M. Rauth, J. Am. Chem. Soc., 1985, 107, 1762.
- 32 D.I. Edwards, R.C. Knight, D.A. Rowley, and I.M. Skolimowski, J. Antimicrob. Chemother., 1983, 12, 535.
- 33 (a) D. Lloyd and J.Z. Pedersen, J. Gen. Microbiol., 1985, 131, 87; P.D. Josephy and R.P. Mason in "Bioactivation of Foreign Compounds", Ed. M.W. Anders, Academic Press, Orlando, 1985 and references therein; (b) E. Perez-Reyes, B. Kalyanaraman, and R.P. Mason, Mol. Pharmacol., 1980, 17, 239.

- 34 M.C.R. Symons and W.R. Bowman, J. Chem. Soc. Perkin Trans. II, 1988, 1077.
- 35 I.M. Skolimowski, D.A. Rowley, R.C. Knight, and D.I. Edwards, J. Antimicrob. Chemother., 1981, 7, 593.
- 36 E. Gattavecchia, D. Tonelli, and P.G. Fuochi, Int. J. Radiat. Biol., 1984, 47, 469.
- 37 R.J. Knox, D.I. Edwards, and R.C. Knight, Int. J. Radiat. Oncol. Biol. Phys., 1984, 10, 1315.
- 38 E. Gattavecchia, D. Tonelli, A. Breccia, and S. Roffia, Int. J. Radiat. Biol., 1982, 42, 105.
- 39 W. Ehlerdt, B.B. Beaulieu Jr., and P. Goldman, J. Med. Chem., 1988, 31, 323.
- 40 A.R. Katritzky, "Handbook of Heterocyclic Chemistry", Pergamon Press, Oxford, 1985, pp.424-428.
- 41 W.S. Allsebrook, J.M. Gulland, and L.F. Story, J. Chem. Soc., 1942, 232.
- 42 (a) F.L. Pyman, J. Chem. Soc., 1922, 121, 2616; (b) W.G. Forsyth, and F.L. Pyman, J. Chem. Soc., 1925, 127, 573.
- 43 V. Sunjic, T. Fajdiga, M. Fapell, and P. Rems, J. Het. Chem., 1969, 5, 6.
- 44 A.O. Ilvespaa, and R. Jarumlinta, Ind. J. Chem., 1982, 21B, 923.
- 45 K. Nagarajan, V.P. Arva, T. George, V. Sundarsanam, R.K. Shah, A. Nagana Goud, S.J. Shenoy, V. Honkan, Y.S. Kulkarni and M.K. Rao, Ind. J. Chem., 1982, 21B, 928.
- 46 K. Nagarajan, V.P. Arva, T. George, G.A. Bat, Y.S. Kulkarni, S.J. Shenoy, and M.K. Rao, Ind. J. Chem., 1982, 21B, 949.
- 47 C.E. Hazeldine, F.L. Pyman, and J. Winchester, J. Chem. Soc., 125, 1431.
- 48 C. Cosar, C. Crisan, R. Horclois, R.M. Jacob, J. Robert, S. Tchelitcheff, and R. Vaupre, Arzneim Forsch., 1966, 16, 23.
- 49 M.W. Miller, H.L. Howes, R.V. Kasubick, and A.R. English, J. Med. Chem., 1970, 13, 849.

- 50 M.P. Crozet, P. Vanelle, O. Jentzer, and M.P. Bertrand, Heterocycles, 1989, 28, 849.
- 51 R.C. Knight, D.A. Rowley, I.M. Skolimowski, and D.I. Edwards, Int. J. Radiat. Biol., 1979, 36, 367.
- 52 R.J. Knox, R.C. Knight, and D.I. Edwards, Biochem. Pharmac., 1981, 30, 1925.
- 53 R.J. Knox, R.C. Knight, and D.I. Edwards, Int. J. Radiat. Biol., 1982, 41, 465.
- 54 M.V. Middiestadt, and A.M. Rauth, Int. J. Radiat. Oncol. Biol. Phys., 1982, 8, 709.
- 55 D.A. Rowley, R.C. Knight, I.M. Skolimowski, and D.I. Edwards, Biochem. Pharmac., 1980, 29, 1095.
- 56 P.M. Cullis, M.C.R. Symons, and B.W. Wren, J. Chem. Soc. Perkin Trans. II, 1985, 1819.
- 57 B. Geise, "Radicals in Organic Synthesis: Formation of Carbon-Carbon Bonds", Pergamon Press, Oxford, 1986, pp56-57.
- 58 S.S. Daly, W.A. Smith Jr., J.D. Vaughan, and V.L. Vaughan, J. Org. Chem., 1980, 45, 3108.
- 59 B.E. Boulton, and B.A.W. Collier, Aust. J. Chem., 1974, 27, 2331.
- 60 E. Arauner and H. Pauly, Chem. Ber., 1928, 118, 33.
- 61 K. Gunderman and H. Pauly, Chem. Ber., 1908, 41, 3999.
- 62 L. Light, and F.L. Pyman, J. Chem. Soc., 1922, 3, 2627.
- 63 I.E. Balaban and F.L. Pyman, J. Chem. Soc., 1924, 125, 1564.
- 64 I.E. Balaban and F.L. Pyman, J. Chem. Soc., 1922, 121, 947.
- 65 J.P. Dickens, R.L. Dyer, B.J. Hamoill, T.A. Harrow, R.H. Bible Jr., P.M. Finnegan, K. Kenrick, P.G. Owston, J. Org. Chem., 1981, 46, 1781.
- 66 V. Calo, F. Ciminale, L. Lopez, and P.E. Todesco J. Chem. Soc., Chem. Comm., 1971, 3652.
- 67 V. Calo, F. Ciminale, L. Lopez, F. Nasco, and P.E. Todesco J. Chem. Soc. Perkin Trans. I, 1972, 2567.

- 68 J.A. Joule and G.F. Smith, "Heterocyclic Chemistry", Van Nostrand Reinhold, Thetford, 1986, p.310-311.  
\*
- 70 V.V. Burykin, B.D. Sadekov, and B.A. Tertov, Khim. Geterotskl. Soedin., 1967, 3, 327.
- 71 B. Iddon and B.L. Lim, J. Chem. Soc., Perkin Trans. I., 1983, 271.
- 72 M.C.R. Symons, W.R. Bowman, and P.F. Taylor, Tetrahedron Lett., 1989, 30, 1409.
- 73 W.R. Bowman, and P.F. Taylor, J. Chem. Soc., Perkin Trans. I., 1990, 919.
- 74 G.F. Meiss, J.F. Bunnett, and A.L. Beckwith, J. Am. Chem. Soc., 1986, 108, 4899.
- 75 A.N. Abeywickrema, A.L.J. Beckwith, and S. Gerba, J. Org. Chem., 1987, 52, 4072; and references therein.
- 76 A.N. Abeywickrema, and A.L.J. Beckwith, Tetrahedron Lett., 1986, 27, 10; J. Chem. Soc., Chem. Comm., 1986, 464.
- 77 D.R. Carver, A.P. Komin, J.S. Hubbard, and J.F. Wolfe, J. Org. Chem., 1981, 46, 294.
- 78 J.F. Wolfe and D.R. Carver, Org. Preps. and Procedures Int., 1978, 10, 227.
- 79 R.A. Rossi, and R.D. Rossi, "Aromatic Substitution by the S<sub>RN</sub>1 mechanism", A.C.S., Washington D.C., 1983.
- 80 A. Lablache-Combier in "Photoinduced Electron Transfer", eds. M.A. Fox and M. Channon, Elsevier, Amsterdam, 1988, part C, p.134.
- 81 J.F. Bunnett and X. Creary, J. Org. Chem., 1974, 39, 5300.
- 82 B. Iddon, N. Khan, and B.L. Lim, J. Chem. Soc., Perkin Trans. I., 1987, 1437.
- 83 M.C.R. Symons and W.R. Bowman, J. Chem. Soc., Perkin Trans. II., 1983, 25.
- 84 S.M. Brothers and R.A. McClelland, J. Org. Chem., 1987, 52, 1357.
- 85 S. Cusamo and G. Didonna, Gazz. Chim. Ital., 1955, 85, 208.

- 86 E.H. Bartlett, C. Eaborn, and D.R.M. Walton, J. Chem. Soc. (C), 1970, 1717.
- 87 K. Rush, Chem. Het. Compounds, 1972, 25, 537.
- 88 J.M. Tedder and B. Webster, J. Chem. Soc., 1960, 3270.
- 89 A. Kreuzberger and P.A. Kalter, J. Org. Chem., 1961, 26, 3790.
- 90 H. Heaney and S.V. Ley, J. Chem. Soc., Perkin Trans. I, 1973, 499.
- 91 M.C.R. Symons, W.R. Bowman, and P.F. Taylor, Accepted for publication in Tetrahedron Lett.
- 92 E.J. Geels, R. Konaka, and G.A. Russell, J. Chem. Soc., Chem. Comm., 1965, 13.
- 93 F.J. Smentowski, J. Am. Chem. Soc., 1963, 85, 3036.
- 94 C.W. Mills, J. Chem. Soc., 1898, 925.
- 95 N. Cambell, A.W. Henderson, and D. Taylor, J. Chem. Soc., 1953, 1281.
- 96 N.J. Leonard, K.L. Carraway, and J.F. Helgeson, J. Het. Chem., 1965, 2, 291; J.A. Montgomery and H.J. Thomas, J. Het. Chem., 1964, 1, 115.
- 97 R.G. Fargher and F.L. Pyman, J. Chem. Soc., 1919, 217.
- 98 N. Campbell and R.C. Cooper, J. Chem. Soc., 1935, 1208.
- \* 69 J.H. Ridd and B.V. Smith, J. Chem. Soc., 1960, 1363.

APPENDIX

Work undertaken during industrial training period with the  
Boots Company p.l.c. (Nottingham)

Due to the constraints of confidentiality, specific details of the work undertaken whilst at Boots in Nottingham cannot be given. However, the functional group transformations involved are outlined below to give a view of the synthetic methodology employed.

Route 1:

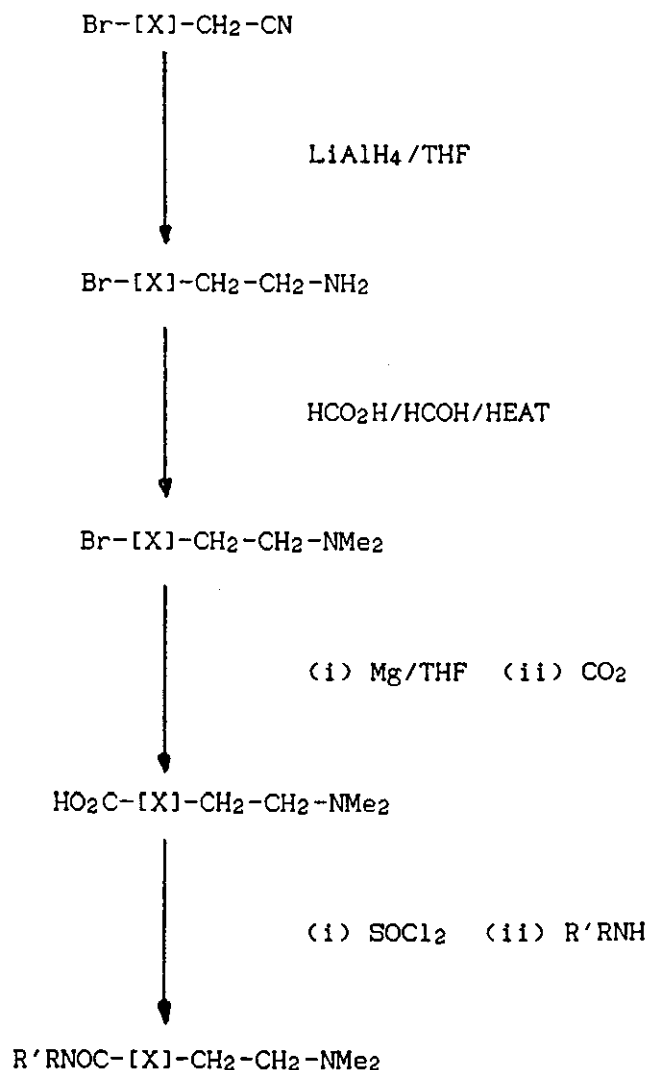

R'RN = NH<sub>2</sub>, NMe<sub>2</sub>

Route 2:

